

BHT

BHT FORGE



- Choke Valves
- Plug Valves
- Flow Line
- Wellhead Production
- Hammer Union
- Forge Fitting
- Flanges

Our Location :

Plot No. G-1870, Kishan Gate Main Road, G.I.D.C. Metoda,
Ta. Lodhika, Dist. Rajkot - 360021, Gujarat (INDIA)
Mo. +91 94267 85447 Ph. +91 2827 297447
Email : info@bhtforge.com
Web : bhtforge.com

ABOUT US



Our strength in self sustained finances and committed high business ethics has been the key to our growth since our inception in 2015. Besides being manufacturers and distributors oilfield components and equipment's, like Choke Valves, Plug Valves, API 6A Flanges, Adaptor Flanges, Union Changeover and Crossover Adaptors, Hammer Unions, Hose Union Fittings, Integral Union Connections, Pup Joints (Integral and NPST), Swivels Joints, Choke and Kill Manifolds, Ring joint Gaskets etc. We also support the Industrial, Petrochemical and the Oil & Gas industry with our expertise in the Global Supply Chain business. Our manufacturing facilities in India is equipped with forging, heat treatment, machining and testing facilities in compliance with API 20C, API 6A and API SPEC Q1 requirements by American Petroleum Institute.

Our working relations with Master Distributors, whom we support with products shipped directly from our factory in Gujarat, India, and with the support of our domestic and international Logistic providers, gives us a cutting edge to provide the right quality products at competitive rates and timely deliveries. Our experienced and technically qualified sales staff will cater to your requirements and queries with all of our after sales support. Thus ensuring correctness of material, documentary back up and timely project deliveries.

Our clients in the Petrochemical, Oil and Gas sector are major Distributors & Stockiest of Oilfield Components and Equipment's, Onshore and Offshore Rig Builders, Pressure vessel manufacturers, Oilfield equipment manufacturers, overseas contracting companies for Drilling, Exploration, Refining and Production in North & South America, West Africa, Middle East and Asia.

PRODUCT INDEX

	Page No.
Forged Fitting	1
Flanges (ANSI B 16.5)	9
Adapter Flanges	12
API 6A Flanges	12
API 6A Ring Gaskets	13
Hammer Union	14
Hose Union Fittings	15
Integral Union Connections	16
Swivel Joints	17
Swivel Joints / Short Radius	18
Hose Loops	19
Steel Hoses (Pup Joint)	19
Plug Valves	20
Choke Valves	21
2" Positive Choke Valve	21
2" Adjustable Choke Valve	22
3" Adjustable Choke Valve	23
API 6A Adjustable Choke Valves	24
API 6A Positive Choke Valves	25
Seat & Stem	26

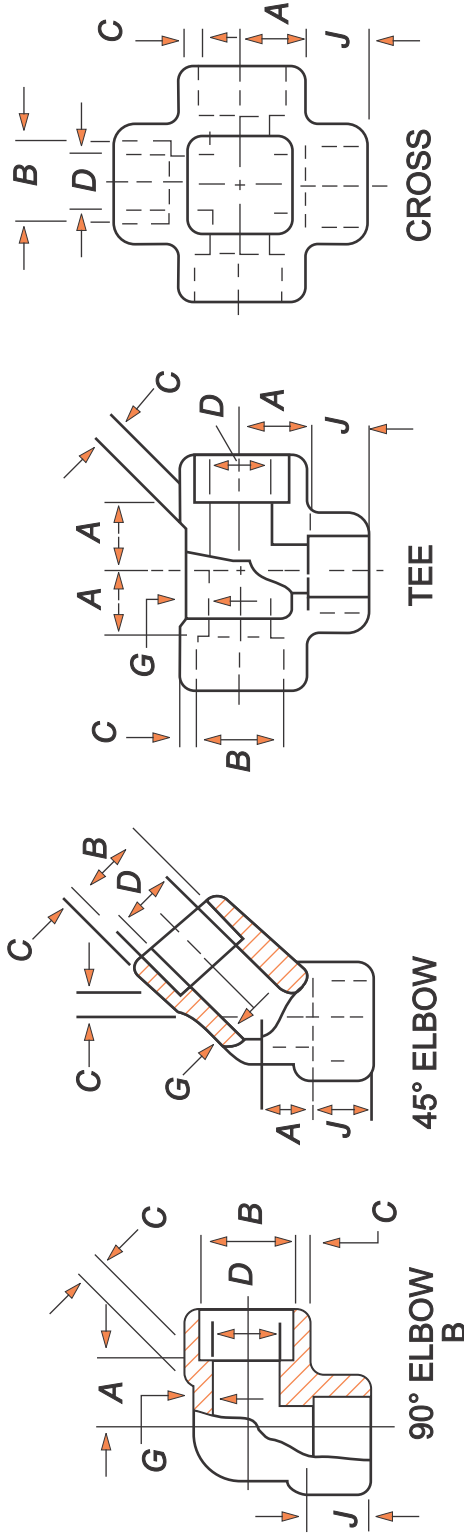

DIMENSIONS OF SOCKET - WELDING FITTINGS (ASME B16.11 - 2016)

Nomi- nal Pipe Size	B		D						C						G						J						A					
	Socket Bore Diam		Bore Diameter of Fitting			Socket Wall Thickness [Note] (1)			Body Wall			Socket Depth, J			Center-to-Bottom of Socket			90 El, Cross, Tee			45-deg Elbow			Tol ±								
	Max.	Min.	3000	6000	9000	3000	6000	9000	Avg.	Min.	3000	6000	9000	Min.	3000	6000	9000	Min.	3000	6000	9000	Min.	3000	6000	9000	3000	6000	9000				
1/8	11.2	10.8	7.6	6.1	4.8	3.2	3.18	3.18	3.18	3.96	3.43	...	2.41	3.15	...	9.5	11.0	11.0	...	8.0	8.0	...	8.0	8.0	...	1.0				
1/4	14.6	14.2	10.0	8.5	7.1	5.6	3.78	3.30	4.01	4.60	4.01	...	3.02	3.68	...	9.5	11.0	13.5	...	8.0	8.0	...	8.0	8.0	...	1.0				
3/8	18.0	17.6	13.3	11.8	9.9	8.4	4.01	3.50	5.03	4.37	3.20	4.01	...	9.5	13.5	15.5	...	8.0	11.0	...	8.0	11.0	...	1.5				
1/2	22.2	21.8	16.6	15.0	12.5	11.0	7.2	5.6	4.67	4.09	5.97	5.18	9.35	8.18	3.73	4.78	7.47	9.5	15.5	19.0	25.5	11.0	12.5	5.5	11.0	12.5	5.5	1.5				
3/4	27.6	27.2	21.7	20.2	16.3	14.8	11.8	10.3	4.90	4.27	6.96	6.04	9.78	8.56	3.91	5.56	7.82	12.5	19.0	22.5	28.5	13.0	14.0	19.0	15.0	14.0	19.0	1.5				
1	34.3	33.9	27.4	25.9	21.5	19.9	16.0	14.4	5.69	4.98	7.92	6.93	11.38	9.96	4.55	6.35	9.09	12.5	22.5	27.0	32.0	14.0	17.5	20.5	20.5	17.5	20.5	2.0				
1 1/4	43.1	42.7	35.8	34.3	30.2	28.7	23.5	22.0	6.07	5.28	7.92	6.93	12.14	10.62	4.85	6.35	9.70	12.5	27.0	32.0	35.0	17.5	20.5	22.5	20.5	17.5	20.5	2.0				
1 1/2	49.2	48.8	41.6	40.1	34.7	33.2	28.7	27.2	6.35	5.54	8.92	7.80	12.70	11.12	5.08	7.14	10.15	12.5	32.0	38.0	38.0	20.5	25.5	25.5	20.5	25.5	25.5	2.0				
2	61.7	61.2	53.3	51.7	43.6	42.1	38.9	37.4	6.93	6.04	10.92	9.50	13.84	12.12	5.54	8.74	11.07	16.0	38.0	41.0	54.0	25.5	28.5	28.5	20.5	25.5	28.5	2.0				
2 1/2	74.4	73.9	64.2	61.2	8.76	7.67	7.01	16.0	41.0	28.5	2.5				
3	90.3	89.8	79.4	76.4	9.52	8.30	7.62	16.0	57.0	32.0	2.5				
4	115.7	115.2	103.8	100.7	10.69	9.35	8.56	19.0	66.5	41.0	2.5				

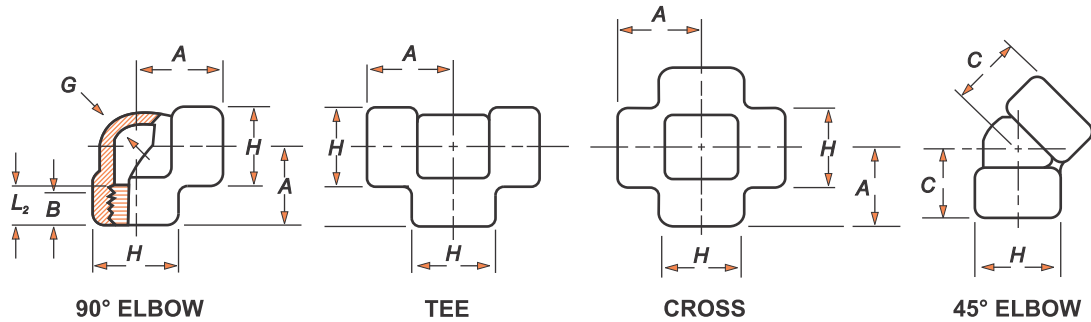

DIMENSIONS OF FORGED THREADED FITTINGS [ASME B 16.11-2016]

Nominal Pipe Size		A			C			H			G			B	
		Center-to-End Elbows, Tees, Crosses, A			Center-to-End 45 deg Elbow, C			Outside Diameter of Band, H			Min. Wall Thickness, G			Min. Length of Thread	
(mm)	(Inch)	2000	3000	6000	2000	3000	6000	2000	3000	6000	2000	3000	6000	B	L2
6	1/8	21	21	25	17	17	19	22	22	25	3.18	3.18	6.35	6.4	6.7
8	1/4	21	25	28	17	19	22	22	25	33	3.18	3.30	6.60	8.1	10.2
10	3/8	25	28	33	19	22	25	25	33	38	3.18	3.51	6.98	9.1	10.4
15	1/2	28	33	38	22	25	28	33	38	46	3.18	4.09	8.15	10.9	13.6
20	3/4	33	38	44	25	28	33	38	46	56	3.18	4.32	8.53	12.7	13.9
25	1	38	44	51	28	33	35	46	56	62	3.68	4.98	9.93	14.7	17.3
32	1.1/4	44	51	60	33	35	43	56	62	75	3.89	5.28	10.59	17.0	18.0
40	1.1/2	51	60	64	35	43	44	62	75	84	4.01	5.56	11.07	17.8	18.4
50	2	60	64	83	43	44	52	75	84	102	4.27	7.14	12.09	19.0	19.2
65	2.1/2	76	83	95	52	52	64	92	102	121	5.61	7.65	15.29	23.6	28.9
80	3	86	95	106	64	64	79	109	121	146	5.99	8.84	16.64	25.9	30.5
100	4	106	114	114	79	79	79	146	152	152	6.55	11.18	18.67	27.7	33.0

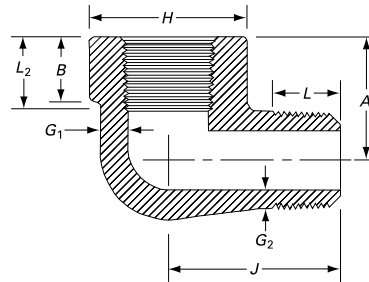

Threaded Street Elbow

Nominal Pipe Size, NPS	A		J		H		G ₁		G ₂		B		L ₂	L
	Center-to-Female End Street Ells, A		Center-to-Female End Street Ells, J		Outside Diameter of Band, H		Minimum Wall Thickness, G ₁		Minimum Wall Thickness, G ₂		Minimum Length Internal Thread, B			
	Class Designation	Class Designation	Class Designation	Class Designation	Class Designation	Class Designation	Class Designation	Class Designation	Class Designation	Class Designation	B	L ₂		
1/8	19	22	25	32	19	25	3.18	5.08	2.74	4.22	6.4	6.7	10	
1/4	22	25	32	38	25	32	3.30	5.66	3.22	5.28	8.1	10.2	11	
3/8	25	28	38	41	32	38	3.51	6.98	3.50	5.59	9.1	10.4	13	
1/2	28	35	41	48	38	44	4.09	8.15	4.16	6.53	10.9	13.6	14	
3/4	35	44	48	57	44	51	4.32	8.53	4.88	6.86	12.7	13.6	16	
1	44	51	57	66	51	62	4.98	9.93	5.56	7.95	14.7	17.3	19	
1 1/4	51	54	66	71	62	70	5.28	10.59	5.56	8.48	17.0	18.0	21	
1 1/2	54	64	71	84	70	84	5.56	11.07	6.25	8.89	17.8	18.4	21	
2	64	83	84	105	84	102	7.14	12.09	7.64	9.70	19.0	19.2	22	

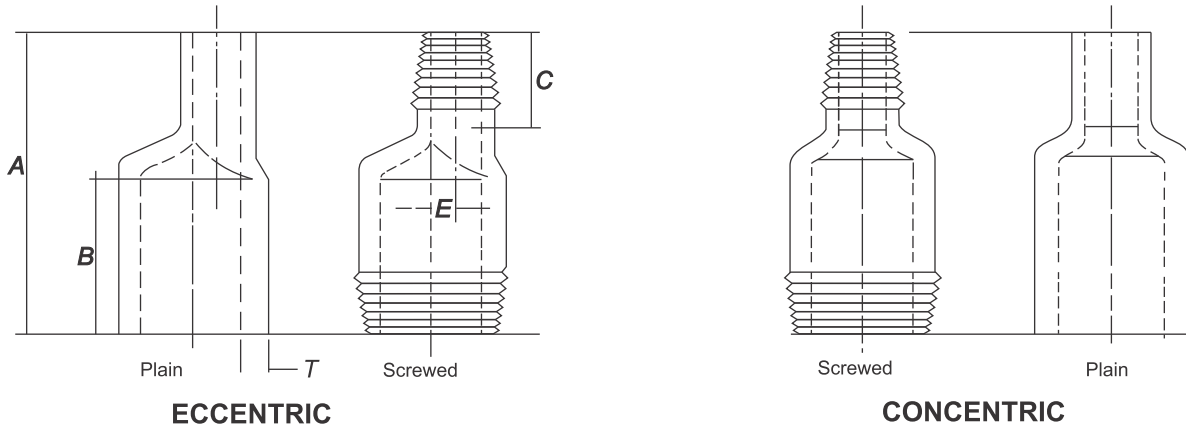

SWAGE NIPPLES [MSS SP 95 - 2018]

Nominal Pipe Size	Parallel length			Eccentricity E	
	(min.) A	(min.) B	(min.) C	3000	6000
10 x 8	76	48	16	1.6	-
15 x 10	89	56	19	1.6	-
15 x 8	89	56	19	3.2	-
20 x 15	95	57	22	2.4	2.4
20 x 10	95	57	22	4.0	-
25 x 20	102	64	22	2.8	2.0
25 x 15	102	64	22	5.2	4.4
40 x 25	114	70	25	6.7	6.4
40 x 20	114	70	25	9.5	8.3
40 x 15	114	70	25	11.9	10.7
50 x 40	165	108	29	5.6	5.2
50 x 25	165	108	29	12.7	11.5
50 x 20	165	108	29	15.5	13.5
40 x 15	165	108	29	17.5	15.9
65 x 50	178	114	32	4.8	3.2
65 x 40	178	114	32	10.3	8.3
80 x 65	203	133	41	7.1	6.7
80 x 50	203	133	41	11.9	9.9
80 x 40	203	133	41	17.5	15.5
100 x 80	229	140	48	11.9	10.7
100 x 65	229	140	48	19.1	17.5

NOTES:

1. All dimensions given in millimeter.
2. Thickness and outside diameters of swage nipples shall correspond to those of the appropriate nominal pipe size.
3. All dimensions herein above are nominal and subject to normal manufacturing tolerances.

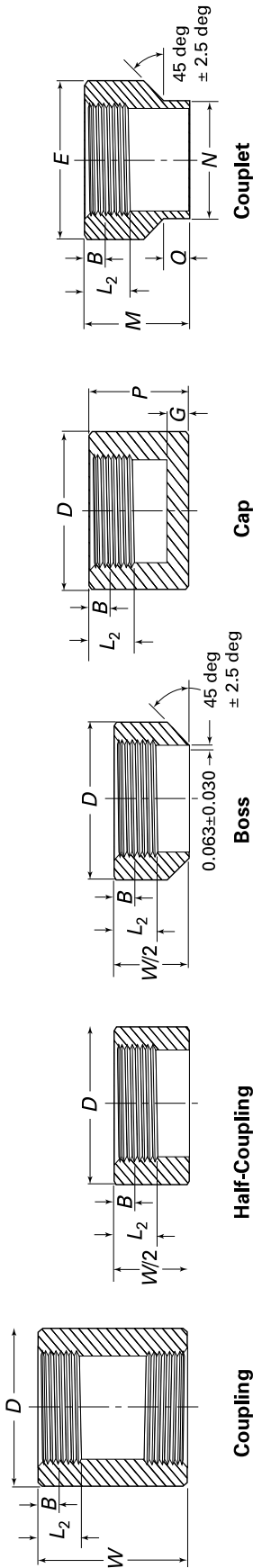

Threaded Couplings, Bosses Caps, and Couplets

Nominal Pipe Size	D		E		W		P		G		Q		N		B		L ₂				
	Outside Diameter, Coupling	3000	Outside Diameter, Couplet	6000	Tol.	End-to-End Coupling	3000/6000	End-to-End Caps	3000	6000	End-to-End Coupling	3000/6000	Minimum End Wall Thickness	3000/6000	Weld Ring Length	3000/6000		Weld Ring Diameter	3000/6000	Tol.	Minimum Length of Thread [Note(1)]
1/8	16	22	32	19	22	4.8	6.4	4.8	6.4	...	6.4	6.7	6.4	6.7
1/4	19	25	±1.5/-0.0	25.4	±1.5/-0.0	35	25	27	±0.8/+0.0	4.8	6.4	30.2	±0.8/+0.0	4.8	6.4	8.1	10.2	17.5	±1.5/+0.0	8.1	10.2
3/8	22	32	±1.5/-0.0	31.8	±1.5/-0.0	48	32	27	±0.8/+0.0	4.8	6.4	30.2	±0.8/+0.0	4.8	6.4	9.1	10.4	20.7	±1.5/+0.0	9.1	10.4
1/2	28	38	±1.5/-0.0	38.1	±1.5/-0.0	48	32	33	±0.8/+0.0	6.4	7.9	33.4	±0.8/+0.0	6.4	7.9	10.9	13.6	23.8	±1.5/+0.0	10.9	13.6
3/4	35	44	±1.5/-0.0	44.5	±1.5/-0.0	51	37	38	±0.8/+0.0	6.4	7.9	34.9	±0.8/+0.0	6.4	7.9	12.7	13.9	27.0	±1.5/+0.0	12.7	13.9
1	44	57	±1.5/-0.0	57.2	±1.5/-0.0	60	41	43	±0.8/+0.0	9.7	11.2	42.9	±0.8/+0.0	9.7	11.2	14.7	17.3	33.4	±1.5/+0.0	14.7	17.3
1 1/4	57	64	±1.5/-0.0	63.5	±1.5/-0.0	67	44	46	±0.8/+0.0	9.7	11.2	47.6	±0.8/+0.0	9.7	11.2	17.0	18.4	42.9	±1.5/+0.0	17.0	18.4
1 1/2	64	76	±1.5/-0.0	76.2	±1.5/-0.0	79	44	48	±0.8/+0.0	11.2	12.7	50.8	±0.8/+0.0	11.2	12.7	17.8	18.4	49.2	±1.5/+0.0	17.8	18.4
2	76	92	±1.5/-0.0	79.4	±1.5/-0.0	86	48	51	±1.5/+0.0	12.7	15.7	57.2	±1.5/+0.0	12.7	15.7	19.0	19.2	61.9	±1.5/+0.0	19.0	19.2
2 1/2	92	108	±1.5/-0.0	92.1	±1.5/-0.0	92	60	64	±1.5/+0.0	15.7	19.0	63.5	±1.5/+0.0	15.7	19.0	23.6	28.9	73.0	±1.5/+0.0	23.6	28.9
3	108	127	±1.5/-0.0	111.1	±1.5/-0.0	108	65	68	±1.5/+0.0	19.0	22.4	69.9	±1.5/+0.0	19.0	22.4	25.9	30.5	114.3	±1.5/+0.0	25.9	30.5
4	140	159	±1.5/-0.0	141.3	±1.5/-0.0	121	68	75	±1.5/+0.0	22.4	28.4	76.2	±1.5/+0.0	22.4	28.4	27.7	33.0	114.3	±1.5/+0.0	27.7	33.0

GENERAL NOTE : Dimensions are in millimeters.

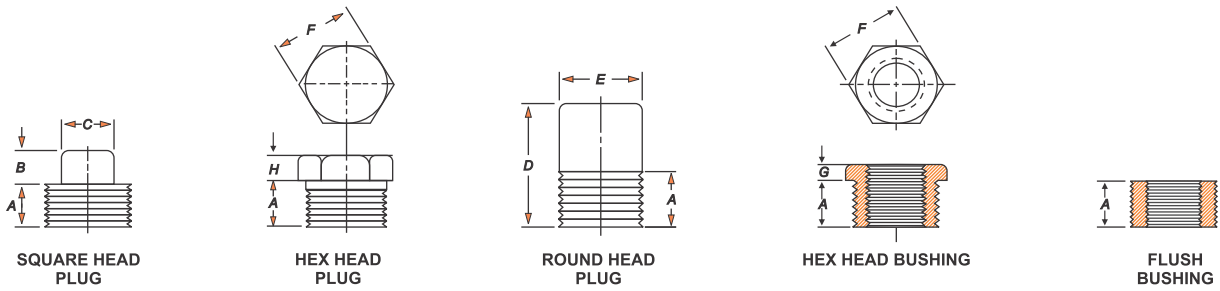

DIMENSIONS OF PLUGS & BUSHINGS [ANSI B 16.11]

Nominal Pipe Size		A	B	C	E	D	F	G	H
		Min. Length	Square Head Plugs		Round Head Plugs		Hex Plugs and Bushings		
			Min. Square Height B	Min. Width Flats, C	Nominal Head Diameter E	Min. Length D	Nominal Width Flats F	Min. Hex Height	
(mm)	(Inch)	A	B	C	E	D	F	Bushing G	Plug H
6	1/8	10	6	7.15	10	35	11.11	...	6
8	1/4	11	6	9.55	14	41	15.9	3	6
10	3/8	13	8	11.11	18	41	17.46	4	8
15	1/2	14	10	14.29	21	44	23	5	8
20	3/4	16	11	15.88	27	44	27	6	10
25	1	19	13	20.64	33	51	34.93	6	10
32	1-1/4	21	14	23.81	43	51	44.45	7	14
40	1-1/2	21	16	28.58	48	51	50.80	8	16
50	2	22	18	33.27	60	64	63.5	9	18
65	2-1/2	27	19	38.1	73	70	76.2	10	19
80	3	28	21	42.86	89	70	88.9	10	21
100	4	32	25	63.5	114	76	117.5	13	25

BULL PLUGS

(As Per MSS SP 95)

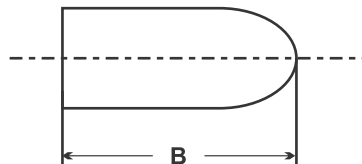

DIMENSIONS OF BULL PLUGS MSS SP 95

Size (Inch)	Outside Diameter (mm)	End To End(mm)
1/8	10.3	51
1/4	13.7	51
3/8	17.1	57
1/2	21.3	64
3/4	26.7	70
1	33.4	76
1-1/4	42.2	83
1-1/2	48.3	89
2	60.3	102
2-1/2	73	127
3	88.9	152
3-1/2	101.6	165
4	114.3	178
5	141.3	216
6	168.3	254
8	219.1	279
10	273	330
12	328.8	356

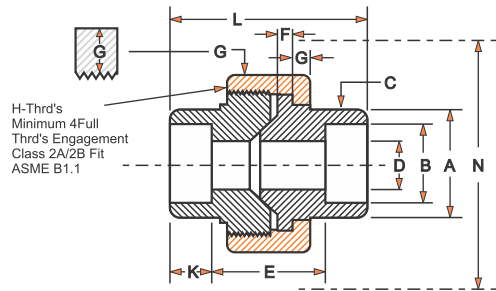

Pipe Unions - Socket Welding Ends Class 3000 (As per MSS SP 83 - 2018)

Nominal Pipe Size	A		B		C	D		E		F	G	H	J	K	L	N
	Min.	Max.	Min.	Max.		Min.	Max.	Min.	Max.							
1/8	21.84	10.67	11.18	3.18	6.07	7.59	19.05	22.35	3.18	3.18	16.00	1.24	9.65	41.40	50.80	
1/4	21.84	14.10	14.61	3.30	8.48	10.01	19.05	22.35	3.18	3.18	16.00	1.24	9.65	41.40	50.80	
3/8	25.91	17.53	18.03	3.51	11.76	13.28	20.57	26.92	3.43	3.43	14.00	1.37	9.65	45.97	55.88	
1/2	31.24	21.72	22.23	4.09	15.04	16.56	20.57	26.92	3.68	3.68	14.00	1.50	9.65	49.02	58.42	
3/4	37.08	27.05	27.56	4.27	20.17	21.69	25.40	31.75	4.06	4.06	11.00	1.68	12.70	56.90	66.04	
1	45.47	33.78	34.29	4.98	25.88	27.41	26.16	34.29	4.57	4.45	11.00	1.85	12.70	61.98	78.74	
1 1/4	54.86	42.55	43.05	5.28	34.29	35.81	32.51	40.64	5.33	5.21	10.00	2.13	12.70	71.12	93.98	
1 1/2	61.47	48.64	49.15	5.54	40.13	41.66	34.29	42.16	5.84	5.59	10.00	2.31	12.70	76.45	111.76	
2	75.18	61.11	61.62	6.05	51.74	2.46	37.34	45.47	6.60	6.35	10.00	2.69	15.75	86.11	132.08	
2 1/2	91.69	73.81	74.45	7.67	61.19	64.24	52.07	61.72	7.49	7.11	8.00	3.07	15.75	102.36	149.86	
3	109.22	89.79	90.42	8.31	76.40	79.45	53.59	63.75	8.26	8.00	8.00	3.53	15.75	108.97	175.26	

Note : (a) The Contact diameter of the male/female tailpiece is affected by the waterway bore (Col. D).
The manufacturer shall consider the relationship between the contact point and Waterway diameter in his design.

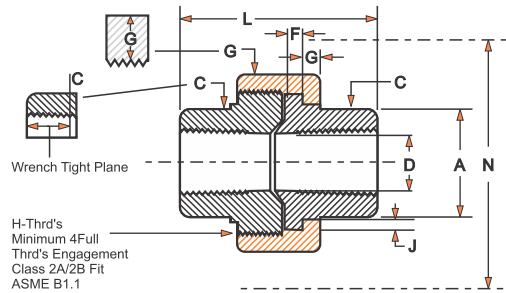

Pipe Unions - Threaded Ends Class 3000 (As per MSS SP 83 - 2018)

Nominal Pipe Size	A	C	D		F	G	H	J	L	N
			Min.	Max.						
1/8	14.73	2.41	6.43	8.43	3.18	3.18	16.00	1.24	41.40	50.80
1/4	19.05	3.02	9.45	11.13	3.18	3.18	16.00	1.24	41.40	50.80
3/8	22.86	3.20	13.51	14.27	3.43	3.43	14.00	1.37	45.97	55.88
1/2	27.69	3.73	17.07	17.86	3.68	3.68	14.00	1.50	49.02	58.42
3/4	33.53	3.91	21.39	23.01	4.06	4.06	11.00	1.68	56.90	66.04
1	41.40	20.07	27.74	28.98	4.57	4.45	11.00	1.85	61.98	78.74
1 1/4	50.55	4.85	35.36	37.69	5.33	5.21	10.00	2.13	71.12	93.98
1 1/2	57.15	5.08	41.20	43.54	5.84	5.59	10.00	2.31	76.45	111.76
2	70.10	5.54	52.12	55.58	6.60	6.35	10.00	2.69	86.11	132.08
2 1/2	85.34	7.01	64.31	66.27	7.49	7.11	8.00	3.07	102.36	149.86
3	102.36	7.62	77.27	82.55	8.26	8.00	8.00	3.53	108.97	175.26

Note : (a) The Contact diameter of the male/female tailpiece is affected by the waterway bore (Col. D).
The manufacturer shall consider the relationship between the contact point and Waterway diameter in his design.

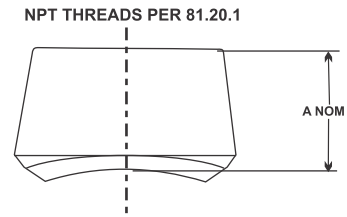
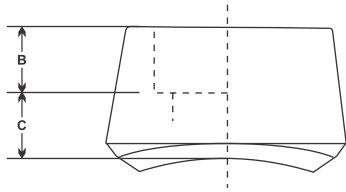

Dimension of Branch Outlet Socket Welding as per MSS SP 97

OUTLET DN	OUTLET NPS	B MIN	C MAX	
			3000	6000
			6	1/8
8	1/4	8	19	
10	3/8	10	21	
15	1/2	15	25	
2	3/4	2	27	32
25	1	25	33	37
32	1.1/4	32	33	40
40	1.1/2	40	35	41
50	2	50	38	43
65	2.1/2	65	46	52
80	3	80	51	
100	4	100	57	

Tolerance : 1/8 - 3/4 ± 0.8MM 1 - 4 ± 1.6mm
Dimensions are in millimeters.

Dimension of Branch Outlet Threaded as per MSS SP 97

OUTLET DN	OUTLET NPS	A FACE OF FITTINGS TO CROTCH THREADED	
		3000	6000
		6	1/8
8	1/4	19	
10	3/8	21	
15	1/2	25	
2	3/4	27	32
25	1	33	37
32	1.1/4	33	40
40	1.1/2	35	41
50	2	38	43
65	2.1/2	46	52
80	3	51	
100	4	57	

Tolerance : 1/8 - 3/4 ± 0.8MM 1 - 4 ± 1.6mm
Dimensions are in millimeters.

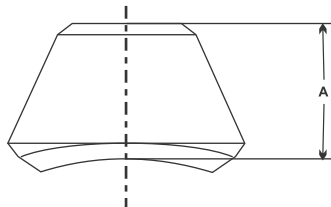

Dimensions are in millimeters.
Tolerance : 1/8-3/4 ± 0.8mm
1 - 4 ± 1.6mm
5 - 12 ± 3.2mm
14 - 24 ± 4.8mm

Dimension of Branch Outlet - Butt Welding as per MSS SP 97

Outlet DN	Outlet NPS	A FACE OF FITTINGS TO CROTCH					
		Standard		Extra Strong		Schedule 160	
		Reducing	Full	Reducing	Full	Reducing	Full
6	1/2	16		16			
8	1/4	16		16			
10	3/8	19		19			
15	1/2	19	19	19	19	28	28
20	1/4	22	22	22	22	32	32
25	1	27	27	27	27	38	38
32	1.1/4	32	32	32	30	44	44
40	1.1/2	33	33	33	33	51	51
50		38	38	38	38	55	55
65	2.1/2	41	41	41	41	62	62
80	3	44	44	44	44	73	73
90	3.1/2	48	51	48	51	-	-
100	4	51	51	51	51	84	84

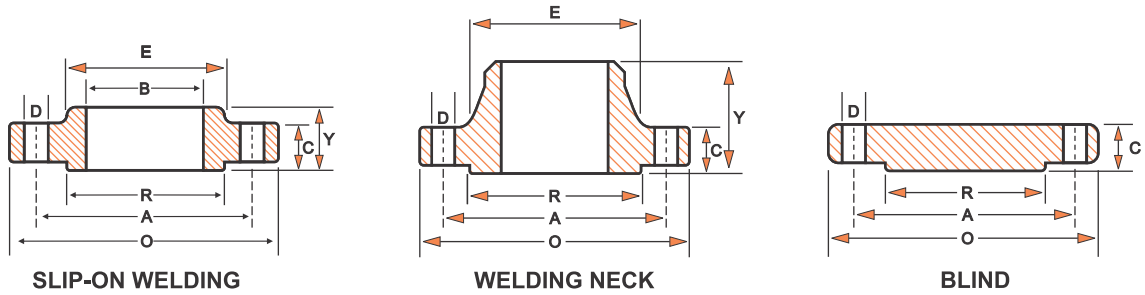

DIMENSIONS OF CLASS 150 FLANGES (ANSI B 16.5)

Nominal Pipe Size (inch)	Flange Dia O	Dia of Bolt Circle A	Dia of Bolt Holes D	No. of Holes	Thk of Flange C	Dia of Hub E	Length through Hub			Dia of Bore		Dia of R/F R	Depth of Socket F	
							S/o. & S/w Y	W/N Y	L/J Y	S/O & S/W B	L/J B			
1/2	15	90	60.3	15.9	4	11.2	30	14	46	16	22.2	22.9	34.9	10
3/4	20	100	69.9	15.9	4	12.8	38	14	51	16	27.7	28.2	42.9	11
1	25	110	79.4	15.9	4	14.3	49	16	54	17	34.5	34.9	50.8	13
1.1/4	32	115	88.9	15.9	4	15.9	59	19	56	21	43.2	43.7	63.5	14
1.1/2	40	125	98.4	15.9	4	17.5	65	21	60	22	49.5	50.0	73.0	16
2	50	150	120.7	19.0	4	19.1	78	24	62	25	61.9	62.5	92.1	17
2.1/2	65	180	139.7	19.0	4	22.3	90	27	68	29	74.6	75.4	104.8	19
3	80	190	152.4	19.0	4	23.9	108	29	68	30	90.7	91.4	127.0	21
4	100	230	190.5	19.0	8	23.9	135	32	75	33	116.1	116.8	157.2	-
5	125	255	215.9	22.2	8	23.9	164	35	87	36	143.8	144.4	185.7	-
6	150	280	241.3	22.2	8	25.5	192	38	87	40	170.7	171.4	215.9	-
8	200	345	298.5	22.2	8	28.6	246	43	100	44	221.5	222.2	269.9	-
10	250	405	362.0	25.4	12	30.2	305	48	100	49	276.2	277.4	323.8	-
12	300	485	431.8	25.4	12	31.8	365	54	113	56	327.0	328.2	381.0	-
14	350	535	476.3	28.6	12	35.0	400	56	125	79	359.2	360.2	412.8	-
16	400	595	539.8	28.6	16	36.6	457	62	125	87	410.5	411.2	469.9	-
18	450	635	577.9	31.7	16	39.7	505	67	138	97	461.8	462.3	533.4	-
20	500	700	635.0	31.7	20	42.9	559	71	143	103	513.1	514.3	584.2	-
24	600	815	749.3	34.9	20	47.7	663	81	151	111	616.0	616.0	692.2	-

DIMENSIONS OF CLASS 300 FLANGES (ANSI B 16.5)

Nominal Pipe Size (inch)	Flange Dia O	Dia of Bolt Circle A	Dia of Bolt Holes D	No. of Holes	Thk of Flange C	Dia of Hub E	Length through Hub			Dia of Bore		Dia of R/F R	Depth of Socket F	
							S/o. & S/w Y	W/N Y	L/J Y	S/O & S/W B	L/J B			
1/2	15	95	66.7	15.9	4	14.3	38	21	51	22	22.2	22.9	34.9	10
3/4	20	115	82.6	19.0	4	15.9	48	24	56	25	27.7	28.2	42.9	11
1	25	125	88.9	19.0	4	17.5	54	25	60	27	34.5	34.9	50.8	13
1.1/4	32	135	98.4	19.0	4	19.1	64	25	64	27	43.2	43.7	63.5	14
1.1/2	40	155	114.3	22.2	4	20.7	70	29	67	30	49.5	50.0	73.0	16
2	50	165	127.0	19.0	8	22.3	84	32	68	33	61.9	62.5	92.1	17
2.1/2	65	190	149.2	22.2	8	25.4	100	37	75	38	74.6	75.4	104.8	19
3	80	210	168.3	22.2	8	28.6	117	41	78	43	90.7	91.4	127.0	21
4	100	255	200.0	22.2	8	31.8	146	46	84	48	116.1	116.8	157.2	-
5	125	298	235.0	22.2	8	35.0	178	49	97	51	143.8	144.4	185.7	-
6	150	320	269.9	22.2	12	36.6	206	51	97	52	170.7	171.4	215.9	-
8	200	380	330.2	25.4	12	41.3	260	60	110	62	221.5	222.2	269.9	-
10	250	445	387.4	28.6	16	47.7	321	65	116	95	276.2	277.4	323.8	-
12	300	520	450.8	31.7	16	50.8	375	71	129	102	327.0	328.2	381.0	-
14	350	585	514.4	31.7	20	54.0	425	75	141	111	359.2	360.2	412.8	-
16	400	650	571.5	34.9	20	57.2	483	81	144	121	410.5	411.2	469.9	-
18	450	710	628.6	34.9	24	60.4	533	87	157	130	461.8	462.3	533.4	-
20	500	775	685.8	34.9	24	63.5	587	94	160	140	513.1	514.3	584.2	-
24	600	915	812.8	41.3	24	69.9	702	105	167	152	616.0	616.0	692.2	-

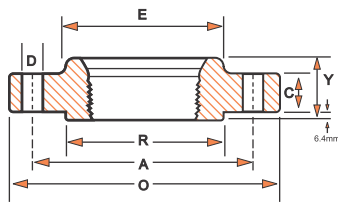

THREADED

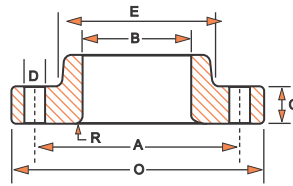

LAPPED

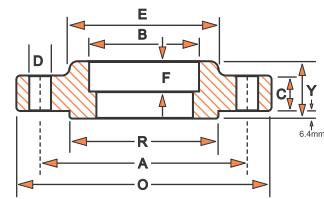

**SOCKET WELDING
(1/2 TO 3 ONLY)**

DIMENSIONS OF CLASS 600 FLANGES (ANSI B 16.5)

Nominal Pipe Size (inch)	Flange Dia (mm)	Dia of Bolt Circle	Dia of Bolt Holes	No. of Holes	Thk of Flange	Dia of Hub	Length through Hub			Dia of Bore		Dia of R/F	Depth of Socket	
							S/o. & S/w	W/N	L/J	S/O & S/W	L/J			
														Y
1/2	15	95	66.7	15.9	4	14.3	38	22	52	22	22.2	22.9	34.9	10
3/4	20	115	82.6	19.0	4	15.9	48	25	57	25	27.7	28.2	42.9	11
1	25	125	88.9	19.0	4	17.5	54	27	62	27	34.5	34.9	50.8	13
1.1/4	32	135	98.4	19.0	4	20.7	64	29	67	29	43.2	43.7	63.5	14
1.1/2	40	155	114.3	22.2	4	22.3	70	32	70	32	49.5	50.0	73.0	16
2	50	165	127.0	19.0	8	25.4	84	37	73	37	61.9	62.5	92.1	17
2.1/2	65	190	149.2	22.2	8	28.6	100	41	79	41	74.6	75.4	104.8	19
3	80	210	168.3	22.2	8	31.8	117	46	83	46	90.7	91.4	127.0	-
4	100	275	215.9	25.4	8	38.1	152	54	102	54	116.1	116.8	157.2	-
5	125	330	266.7	28.6	8	44.5	189	60	114	60	143.8	144.4	185.7	-
6	150	355	292.1	28.6	12	47.7	222	67	117	67	170.7	171.4	215.9	-
8	200	420	349.2	31.7	12	55.6	273	76	133	76	221.5	222.2	269.9	-
10	250	510	431.8	34.9	16	63.5	343	86	152	111	276.2	277.4	323.8	-
12	300	560	489.0	34.9	20	66.7	400	92	156	117	327.0	328.2	381.0	-
14	350	605	527.0	38.1	20	69.9	432	94	165	127	359.2	360.2	412.8	-
16	400	685	603.2	41.3	20	76.2	495	106	178	140	410.5	411.2	469.9	-
18	450	745	654.0	44.4	20	82.6	546	117	184	152	461.8	462.3	533.4	-
20	500	815	723.9	44.4	24	88.9	610	127	190	165	513.1	514.3	584.2	-
24	600	940	838.2	50.8	24	101.6	718	140	203	184	616.0	616.0	692.2	-

DIMENSIONS OF CLASS 900 FLANGES (ANSI B 16.5)

Nominal Pipe Size (inch)	Flange Dia (mm)	Dia of Bolt Circle	Dia of Bolt Holes	No. of Holes	Thk of Flange	Dia of Hub	Length through Hub			Dia of Bore		Dia of R/F	Depth of Socket	
							S/O. & S/W	W/N	L/J	S/O & S/W	L/J			
														Y
1/2	15	120	82.6	22.2	4	22.3	38	32	60	32	22.2	22.9	34.9	10
3/4	20	130	88.9	22.2	4	25.4	44	35	70	35	27.7	28.2	42.9	11
1	25	150	101.6	25.4	4	28.6	52	41	73	41	34.5	34.9	50.8	13
1.1/4	32	160	111.1	25.4	4	28.6	64	41	73	41	43.2	43.7	63.5	14
1.1/2	40	180	123.8	28.6	4	31.8	70	44	83	44	49.5	50.0	73.0	16
2	50	215	165.1	25.4	8	38.1	105	57	102	57	61.9	62.5	92.1	17
2.1/2	65	245	190.5	28.6	8	41.3	124	64	105	64	74.6	75.4	104.8	19
3	80	240	190.5	25.4	8	38.1	127	54	102	54	90.7	91.4	127.0	-
4	100	290	235.0	31.7	8	44.5	159	70	114	70	116.1	116.8	157.2	-
5	125	350	279.4	35.0	8	50.8	190	79	127	79	143.8	144.4	185.7	-
6	150	380	317.5	31.7	12	55.6	235	86	140	86	170.7	171.4	215.9	-
8	200	470	393.7	38.1	12	63.5	298	102	162	114	221.5	222.2	269.9	-
10	250	545	469.9	38.1	16	69.5	368	108	184	127	276.2	277.4	323.8	-
12	300	610	533.4	38.1	20	79.4	419	117	200	143	327.0	328.2	381.0	-

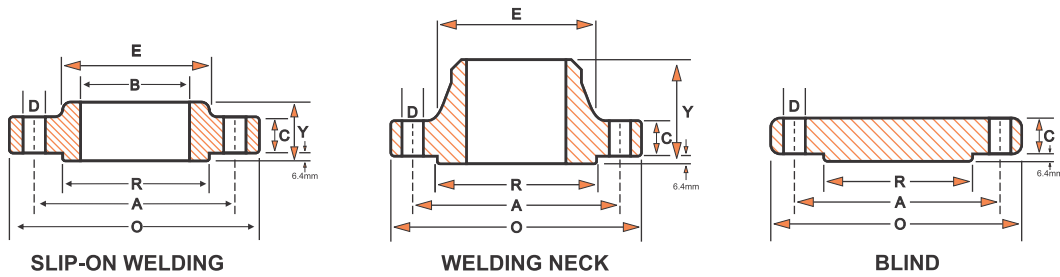

DIMENSIONS OF CLASS 1500 FLANGES (ANSI B 16.5)

Nominal Pipe Size (inch)	Flange Dia O	Dia of Bolt Circle A	Dia of Bolt Holes D	No. of Holes	Thk of Flange C	Dia of Hub E	Length through Hub			Dia of Bore		Dia of R/F R	Depth of Socket F	
							S/o. & S/w Y	W/N Y	L/J Y	S/O & S/W B	L/J B			
1/2	15	120	82.6	22.2	4	22.3	38	32	60	32	22.2	22.9	34.9	10
3/4	20	130	88.9	22.2	4	25.4	44	35	70	35	27.7	28.2	42.9	11
1	25	150	101.6	25.4	4	28.6	52	41	73	41	34.5	34.9	50.8	13
1.1/4	32	160	111.1	25.4	4	28.6	64	41	73	41	43.2	43.7	63.5	14
1.1/2	40	180	123.8	28.6	4	31.8	70	44	83	44	49.5	50.0	73.0	16
2	50	215	165.1	25.4	8	38.1	105	57	102	57	61.9	62.5	92.1	17
2.1/2	65	245	190.5	28.6	8	41.3	124	64	105	64	74.6	75.4	104.8	19
3	80	265	203.2	31.7	8	47.7	133	73	117	73	90.7	91.4	127.0	-
4	100	310	241.3	34.9	8	54.0	162	91	124	90	116.1	116.8	157.2	-
5	125	375	292.1	41.3	8	73.1	197	105	156	105	143.8	144.4	185.7	-
6	150	395	317.5	38.1	12	82.6	229	119	171	119	170.7	171.4	215.9	-
8	200	485	393.7	44.4	12	92.1	292	143	213	143	221.5	222.2	269.9	-
10	250	585	482.6	50.8	12	105.0	368	159	254	178	276.3	277.4	323.8	-
12	300	675	571.5	54.0	16	123.9	451	181	283	219	327.1	328.2	381.0	-

DIMENSIONS OF CLASS 2500 FLANGES (ANSI B 16.5)

Nominal Pipe Size (inch)	Flange Dia O	Dia of Bolt Circle A	Dia of Bolt Holes D	No. of Holes	Thk of Flange C	Dia of Hub E	Length through Hub			Dia of Bore		Dia of R/F R	Depth of Socket F	
							S/o. & S/w Y	W/N Y	L/J Y	S/O & S/W B	L/J B			
1/2	15	135	88.9	22.2	4	30.2	43	40	73	40	22.3	22.9	34.9	10
3/4	20	140	95.2	22.2	4	31.8	51	43	79	43	28.2	28.2	42.9	11
1	25	160	108.0	25.4	4	35.0	57	48	89	48	34.9	34.9	50.8	13
1.1/4	32	185	130.2	28.6	4	38.1	73	52	95	52	43.7	43.7	63.5	14
1.1/2	40	205	146.0	31.7	4	44.5	79	60	111	60	50.0	50.0	73.0	16
2	50	235	171.4	28.6	8	50.9	95	70	127	70	62.5	62.5	92.1	17
2.1/2	65	265	196.8	31.7	8	57.2	114	79	143	79	75.4	75.4	104.8	19
3	80	305	228.6	34.9	8	66.7	133	92	168	92	91.4	91.4	127.0	-
4	100	355	273.0	41.3	8	76.2	165	108	190	108	116.8	116.8	157.2	-
5	125	420	323.8	47.6	8	92.1	203	130	229	130	144.4	144.4	185.7	-
6	150	485	368.3	54.0	8	108.0	235	152	273	152	171.4	171.4	215.9	-
8	200	550	438.2	54.0	12	127.0	305	178	318	178	222.2	222.2	269.9	-
10	250	675	539.8	66.7	12	165.1	375	229	419	229	277.4	277.4	323.8	-
12	300	760	619.1	73.0	12	184.2	441	254	464	254	328.2	328.2	381.0	-

Adapters Flanges

BHT Wellhead Flange Adapters are designed to be used in the upper most position on wellheads and therefore enables wireline and other well service operations to be performed through the wellhead into the well bore.

BHT Wellhead Flange Adapters are available in various bore sizes and with quick union connections compatible with Bowen and Otis type quick unions. Additionally, Flange / Adapters are supplied for standard or H2S service and working pressure up to 15,000 psi.



API 6A Flanges

BHT is a manufacturer of various types of Flanges and Pipe Fittings required by the oilfield, petrochemical and different process industries. Our name is synonymous with high quality manufacturing, precision machining and unparalleled dedication to quality excellence which has kept us in the fore front of the oil industry.



Weld Neck Flange

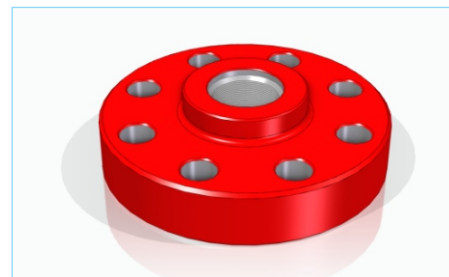

Threaded Flange



Blind Flange

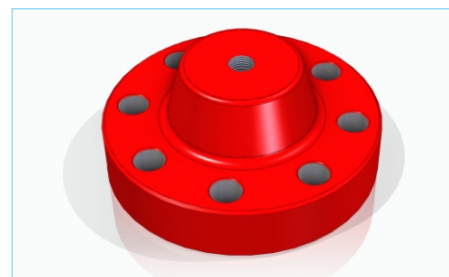

Test Blind Flange

API 6A Ring Gaskets

Precision Finish

- Material Stainless Steel, Low Carbon or Inconel.
- Dual Certification for low Carbon
- Full Traceability

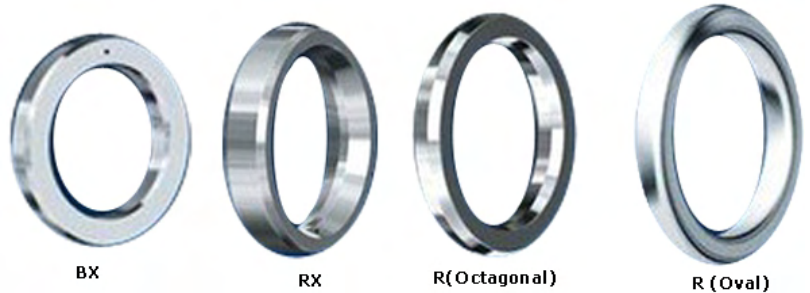

API 6A Spec Flange Bolt & Ring Chart

API Pressure Rating	Flange Size & Bore	Ring Gasket		Number of Studs	Stud Dimensions	
					Diameter	Length
2000 lb	2 1/16"	R-23	RX-23	8	5/8"	4 3/4"
	2 9/16"	R-26	RX-26	8	3/4"	5 1/4"
	3 1/8"	R-31	RX-31	8	3/4"	5 1/2"
	4 1/16"	R-37	RX-37	8	7/8"	6 1/4"
	5 1/8"	R-41	RX-41	8	1"	7 1/4"
	7 1/16"	R-45	RX-45	12	1"	7 1/2"
	9"	R-49	RX-49	12	1 1/8"	8 1/2"
	11"	R-53	RX-53	16	1 1/4"	9 1/4"
	13 5/8"	R-57	RX-57	20	1 1/4"	9 1/2"
	16 3/4"	R-65	RX-65	20	1 1/2"	10 3/4"
6BX	21 1/4"	R-73	RX-73	24	1 5/8"	12 1/2"
	26 3/4"	BX-167		20	1 3/4"	14 1/4"

API Pressure Rating	Flange Size & Bore	Ring Gasket		Number of Studs	Stud Dimensions	
					Diameter	Length
3000 lb	2 1/16"	R-24	RX-24	8	7/8"	6"
	2 9/16"	R-27	RX-27	8	1"	7"
	3 1/8"	R-31	RX-31	8	7/8"	6 1/4"
	4 1/16"	R-37	RX-37	8	1 1/8"	7 1/2"
	5 1/8"	R-41	RX-41	8	1 1/4"	8 1/4"
	7 1/16"	R-45	RX-45	12	1 1/8"	8 1/2"
	9"	R-49	RX-49	12	1 3/8"	9 1/2"
	11"	R-53	RX-53	16	1 3/8"	10"
	13 5/8"	R-57	RX-57	20	1 3/8"	10 3/4"
	16 3/4"	R-66	RX-66	20	1 5/8"	12 1/4"
6BX	20 3/4"	R-74	RX-74	20	2"	15"
	26 3/4"	BX-168		24	2"	17 1/2"

API Pressure Rating	Flange Size & Bore	Ring Gasket		Number of Studs	Stud Dimensions	
					Diameter	Length
5000 lb	2 1/16"	R-24	RX-24	8	7/8"	6 1/4"
	2 9/16"	R-27	RX-27	8	1"	7"
	3 1/8"	R-35	RX-35	8	1 1/8"	7 3/4"
	4 1/16"	R-39	RX-39	8	1 1/4"	8 1/2"
	5 1/8"	R-44	RX-44	8	1 1/2"	10 3/4"
	7 1/16"	R-46	RX-46	12	1 3/8"	11 1/4"
	9"	R-50	RX-50	12	1 5/8"	12 1/2"
	11"	R-54	RX-54	12	1 7/8"	14 1/2"
	13 5/8"	BX-160		16	1 5/8"	12 3/4"
	16 3/4"	BX-162		16	1 7/8"	14 3/4"
6BX	18 3/4"	BX-163		20	2"	17 1/2"
	21 1/4"	BX-165		24	2"	18 3/4"

API Pressure Rating	Flange Size & Bore	Ring Gasket		Number of Studs	Stud Dimensions	
					Diameter	Length
10000 lb	1 13/16"	BX-151		8	3/4"	5 1/4"
	2 1/16"	BX-152		8	3/4"	5 1/2"
	2 9/16"	BX-153		8	7/8"	6 1/4"
	3 1/16"	BX-154		8	1"	7 1/4"
	4 1/16"	BX-155		8	1 1/8"	8 1/4"
	5 1/8"	BX-169		12	1 1/8"	9"
	7 1/16"	BX-156		12	1 1/2"	11 3/4"
	9"	BX-157		16	1 1/2"	13 1/4"
	11"	BX-158		16	1 3/4"	15 1/2"
	13 5/8"	BX-159		20	1 7/8"	17 3/4"
	16 3/4"	BX-162		24	1 7/8"	17 3/4"
	18 3/4"	BX-164		24	2 1/4"	22 1/2"
	6BX	21 1/4"	BX-166		24	2 1/2"

































































































API Pressure Rating	Flange Size & Bore	Ring Gasket		Number of Studs	Stud Dimensions	
					Diameter	Length
15000 lb	1 13/16"	BX-151		8	7/8"	5 3/4"
	2 1/16"	BX-152		8	7/8"	6 1/4"
	2 9/16"	BX-153		8	1"	7"
	3 1/16"	BX-154		8	1 1/8"	8"
	4 1/16"	BX-155		8	1 3/8"	9 1/2"
	5 1/8"	BX-169		12	1 1/2"	11 1/2"
	7 1/16"	BX-156		16	1 1/2"	13"
	9"	BX-157		16	1 7/8"	15 3/4"
	11"	BX-158		20	2"	19 1/2"
	13 5/8"	BX-159		20	2 1/4"	21"
6BX	18 3/4"	BX-164		20	3"	26 3/4"

API Pressure Rating	Flange Size & Bore	Ring Gasket		Number of Studs	Stud Dimensions	
					Diameter	Length
20000 lb	1 13/16"	BX-151		8	1"	7 3/4"
	2 1/16"	BX-152		8	1 1/8"	8 1/2"
	2 9/16"	BX-153		8	1 1/4"	9 1/2"
	3 1/16"	BX-154		8	1 3/8"	10 1/4"
	4 1/16"	BX-155		8	1 3/4"	12 1/4"
	7 1/16"	BX-156		16	2"	17 3/4"
	9"	BX-157		16	2 1/2"	21 3/4"
	11"	BX-158		16	2 3/4"	23 3/4"
	13 5/8"	BX-159		20	3"	30"
6BX						

Hammer Unions

BHT hammer unions are available in a wide range of sizes and in working pressures to 15,000 psi. Pressure seal, non-pressure seal, and welded styles are offered in various sizes. All BHT hammer unions provide pressure-tight, positive sealing and are available for standard services and sour gas models. BHT hammer unions for sour gas services are specially heat-treated for controlled hardness and utilises fluorocarbon elastomer seal rings.

Specifications For Threaded and Butt Weld Hammer Unions

Fig. No.	Assembly Color Code for Standard Service	Pressure Rating (PSI)				Nominal Pipe Sizes															
		Standard Service		Sour Gas Service		(in.)	1/2	1	1-1/4	1-1/2	2	2-1/2	3	4	5	6	8	10	12		
		Cold Working	Test	Cold Working	Test	(mm)	13	25	32	38	50	65	80	100	125	150	200	250	300		
50		500	750	N/A	N/A																
100		1,000	1,500	N/A	N/A																
101		1,000	1,500	N/A	N/A																
200		2,000	3,000	2,000	3,000																
201		2,000	3,000	2,000	3,000																
206		2,000	3,000	2,000	3,000																
207		2,000	3,000	2,000	3,000																
211		2,000	3,000	N/A	N/A																
300		2,000	3,000	N/A	N/A																
400		4,000	6,000	4,000	6,000																
602		6,000	9,000	6,000	9,000																
1002		10,000	15,000	7,500	11,250																
1003		10,000	15,000	7,500	11,250																
1004		10,000	15,000	7,500	11,250																
1502		15,000	22,500	10,000	15,000																
2002		20,000	30,000	N/A	N/A																
2202		N/A	N/A	15,000	22,500																
6666		6,000	9,000	N/A	N/A																

* Indicates different Cold Working Pressure due to other design factor - Difference as shown below:

- 5", 6", 12": Figure 400, Cold Working Pressure 2,500 PSI & Test Pressure 4,000 PSI
- 5", 6" : Figure 1002 Butt weld, Cold Working Pressure 7,500 PSI & Test Pressure 11,250 PSI Std. Service
- 4", 5" : Figure 1003 Butt weld, Cold Working Pressure 7,500 PSI & Test Pressure 11,250 PSI Std. Service
- 5", 6" : Figure 1002 Butt weld, Cold Working Pressure 5,000 PSI & Test Pressure 7,500 PSI Sour Service
- 4", 5" : Figure 1003 Butt weld, Cold Working Pressure 5,000 PSI & Test Pressure 7,500 PSI Sour Service
- 1/2" : Figure 300, Cold Working Pressure 15,000 PSI & Test Pressure 20,000 PSI, Zinc Plated

Hammer Unions



**Fig. 100
Black Nut Yellow Subs**
An economical union with precision machined metal-to-metal sealing surfaces for air, water, oil or gas service to 1,000 psi NSCWP*.



**Fig. 200
Blue Nut Gray Subs**
A precision metal-to-metal sealing surface between male and female subs for air, water, oil, gas and mud service to 2,000 psi NSCWP*.



**Fig. 206
Blue Nut Gray Subs**
A precision metal-to-metal seal plus O-ring seal for air, water, oil, gas and mud service to 2,000 psi NSCWP*.



**Fig. 207
Blue Cap Gray Subs**
Interchangeable Fig. 206 sub with blanking cap and O-ring seal to assure no-leak closure of manifolds and lines to 2,000 psi NSCWP*.



**Fig. 400
Black Nut Red Subs**
Features a precision ball and cone sealing surface for sure metal-to metal seal for air, water, oil, gas and mud service to 4,000 psi NSCWP*.



**Fig. 402
Black Nut Black Subs**
A resilient lip-type seal for air, water, oil or mud service to 4,000 psi NSCWP*.



**Fig. 602
Black Nut Orange Subs**
A replaceable lip-type seal ring minimizes fluid flow turbulence and gives pressure seal for air, water, oil, gas and mud service to 6,000 psi NSCWP*.

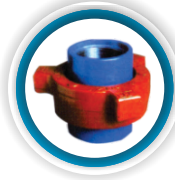

**Fig. 1002
Red Nut Blue Subs**
A resilient lip-type seal protects ball and cone seal against abrasion in air, water, oil, gas and mud service to 10,000 psi NSCWP*.



**Fig. 1502
Blue Nut Red Subs**
For manifold and truck mountings or installations encountering high pressures including air, water, oil, gas and mud services to 15,000 psi NSCWP*.



**Fig. 2002
White Nut White Subs**
For cementing, fracturing, acidizing, testing and choke-and-kill lines where extreme pressures are encountered to 20,000 psi NSCWP*.



**Fig. 2202
Green Nut Green Subs**
Especially for sour gas service; with heat-treated components, fluoroelastomer seal rings. For service to 15,000 psi NSCWP*.

Hose Union Fittings



BHT Figure 206 Hose Fitting is constructed of high quality cast ductile iron. This union is also referred to as a Hose Barb Union. It features a union end connection that is interchangeable with a figure 200/206 connection, and it comes with an integral hose shank on both the male and female sub. The figure 206 union is designed to save time and money by eliminating the need to weld a hose nipple onto a figure 200/206 hammer union. This union is uniquely designed to be tested to twice the rated working pressure, which is often a requirement for hoses used in oilfield applications.

Standard Service		H2S Service**	
NSCWP	Test	NSCWP	TEST
400 PSI	800 PSI	400 PSI	800 PSI

*All Working Pressures are Non-shock Cold Working Pressure Ratings (NSCWP)

Integral Union Connections

BHT manufactures a quality line of high-pressure integral union connections in a broad range of configurations and sizes from 2" and 3" and in pressure ratings to 15,000 psi NSCWP*. Manufactured from high strength alloy steel, BHT integrals feature a lightweight design which is not found in competitors' products. All BHT integral union connections are subjected to controlled heat-treat process.

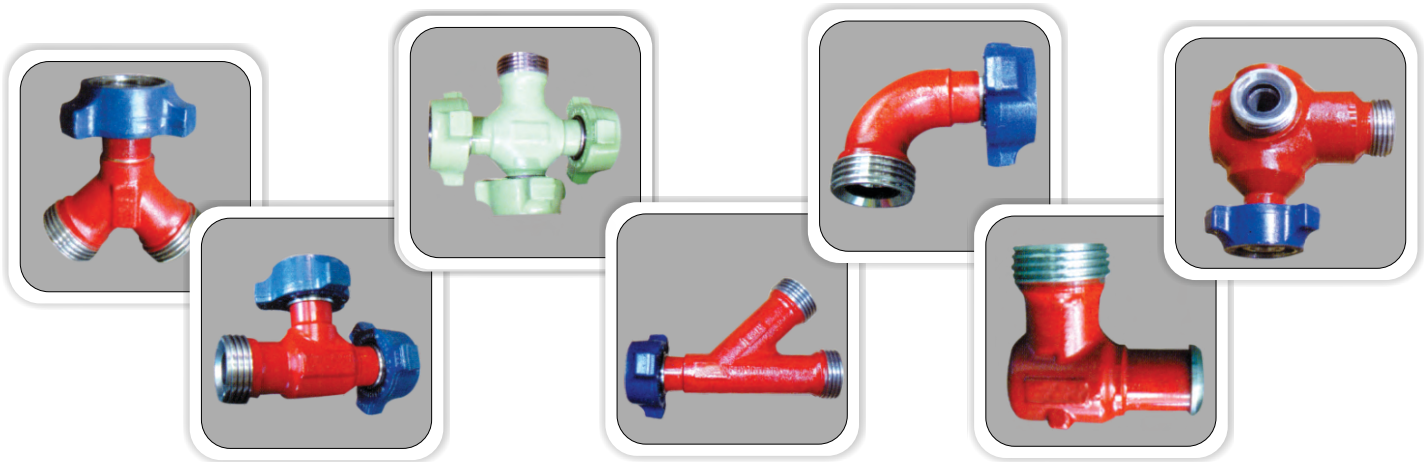

Size	Fig. 602 6,000 psi*	Fig. 1002 10,000 psi*	Fig. 1502 15,000 psi*	Fig. 1502 10,000 psi* H25	Fig. 2002 15,000 psi*	All Female (Thread)	All Male (Wing)	Combination styles and Sizes
2"			●	●	●	●	●	●
3"	●		●	●	●	●	●	●

*Non-Shock Cold Working Pressure

Union Changeover And Crossover Adaptors



Available in a variety of sizes and thread types in female-to-male, female-to-female, and male-to-male configurations from 1" thru 4", in pressure rating from 6,000 to 15,000 psi NSCWP* in standard service, and up to 10,000 psi in sour gas service.

Union Bull, Gauge And Lifting Bull Plugs



Available in a variety of sizes and thread types in female-to-male, female-to-female, and male-to-male configurations from 1" thru 4", in pressure rating from 6,000 to 15,000 psi NSCWP* in standard service, and up to 10,000 psi in sour gas service.

Union Male And Female To Pipe And Tubing Thread Swages

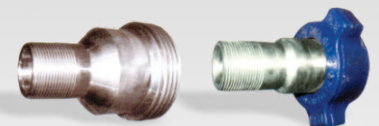

Available in numerous sizes and threaded configurations from 1" thru 4" in pressure rating from 6,000 to 10,000 psi NSCWP*.

Swivel Joints

BHT 2" Fig. 1502 and 3" Fig 1502 Long Radius Swivel Joints have undergone a design enhancement, creating a superior and longer lasting product. New features have created a swivel with extended life while maintaining uniform flow.

New features include:

- Additional erosion material under critical ball race locations.
- More stable assembly with better load distribution in 3" Fig. 1502 series, featuring longer ball race life.
- Better distribution of material for more robust female ball race components in 2" Fig. 1502 and 3" Fig. 1502 models.
- No danger for any mismatches.
- Available in traditional hammer union styles.



All BHT swivel joints feature uniform wall thickness throughout for longer and more uniform flow of fluids (including slurries and abrasives), elastomeric packing for service to instream packing that is designed not to enter stream regardless of velocity and improved lubrication.

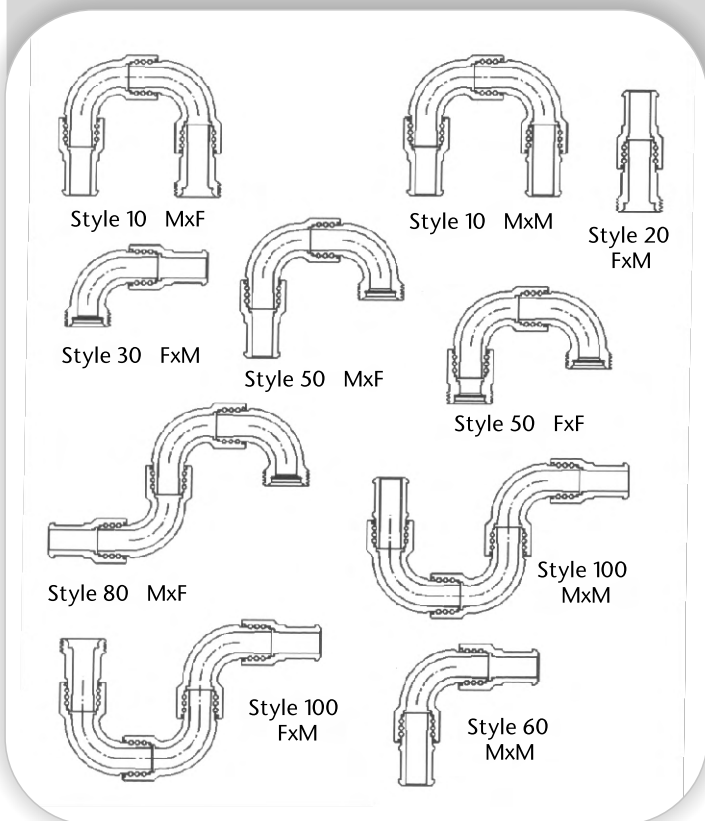

Pressure Rating	Size			
	2"	2" H2S	3	3" H2S
Style 10 Fig. 1502 MxF	●	●	●	●
Style 10 Fig. 1502 MxM	●	●	●	●
Style 20 Fig. 1502 MxF	●	●	●	●
Style 30 Fig. 1502 MxF	●	●	●	●
Style 50 Fig. 1502 MxF	●	●	●	●
Style 60 Fig. 1502 MxF	●	●	●	●
Style 80 Fig. 1502 MxF	●		●	●
Style 50 Fig. 602 MxF				
Style 100 Fig. 1502 MxF	●	●	●	
Style 100 Fig. 1502 MxM	●	●	●	

Swivel Joint / Short Radius



- Size : 2"
- End Type : customized
- Test Pressure : 9,000psi
- CWP : 6,000psi (413.68 bar)
- Service : Standard, H₂S
- Used for Cementing, Drill Mud, Fracturing Fluids, Well Servicing
- MTR and Test Report are offered at any time

Swivel Joint Short Radius Repair Kit

NO	Item	Q'ty
-	Repair Kit Set	-
1	O-ring	1
2	Pressure Seal	1
3	Ball	52
4	Nipple Nut O-ring	1
5	Nipple Nut	1
6	Grease Fitting	1



Style 10



Style 20



Style 30



Style 40



Style 50



Style 60



Style 70



Style 80

Hose Loops

BHT hose loops are used for a variety of high pressure well service applications including discharge lines, water lines, cementing and circulating lines, well test lines and temporary flow lines.

BHT hoses utilize field proven BHT swivel joints for greater flexibility, shock and vibration resistance, and more uniform flow. Also utilized are BHT wing union end connections for fast, pressure tight make-up and break-out.

These rugged hoses handle a full range of fluids to cold working pressures up to 15,000 psi and come in sizes and configurations to meet any need. Hoses for sour gas service are available at cold working pressure up to 10,000 psi. OFE hoses are designed to easily and conveniently fold up for storage and transportation.

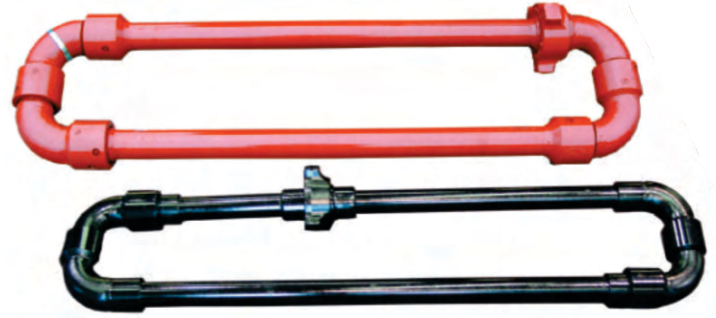

BHT Model	Color Code	Method of Construction			NSCWP* (PSI)	Size (In.)	
		Threaded	NPS	Integral		2	3
Long Radius Swivel Joints	Olive Green†		•	•	10,000	•	•
	Red		•	•	15,000	•	•
Long Radius Swivel Joints	Black	•			10,000	•	

† Sour Gas Service

*Non-Shock Cold Working Pressure

Steel Hoses (Pup Joint)

OFE Integral pup joints with wing union end connections for an uninterrupted and greater flow.



Integral PUP Joints

This light weight piping is available in lengths up to 10 feet to handle fluids at cold working pressure to 15,000 psi. They are used on high-pressure discharge lines, auxiliary flow lines, choke-and-kill lines and for abrasive applications.



NPST Pup joint

BHT also manufactures flow line piping in non-pressure seal thread from 6,000 to 15,000 psi, up to 20 feet in length.

Integral Style

Size (In.)	Type of Service	NSCWP* (PSI)	End Connection
2	Standard	15,000	Fig. 1502 Union
2	Sour Gas	10,000	Fig. 1502 Union
3	Standard	15,000	Fig. 1502 Union
3	Sour Gas	10,000	Fig. 1502 Union

NPS & Butt Weld Piping

Style	NSCWP* (PSI)	1"	1½"	2"	3"	Non Press Seal	Butt Weld
Fig. 602	6,000	•	•		•	•	•
Fig. 1002	10,000	•	•	•		•	•
Fig. 1502†	10,000	•	•	•	•		•
Fig. 1502	15,000	•	•	•	•	•	•

*Non-Shock Cold Working Pressure

† Sour Gas Service

Plug Valves

- Standard service is used up to 15,000psi and tested at 22,500psi
- H₂S service is used up to 10,000psi and tested at 15,000psi
- Rugged Construction with Forged Alloy Steel Body
- Reliable Performance at high working pressure
- Bottom Entry design, Top Entry design, Easy Maintenance
- Valve Parts are Interchangeable with most major designs
- Suitable for variety of high pressure applications such as fracturing, cementing, acidizing and etc.
- Each valve is serialized
- MTR and Test Report are available at any time

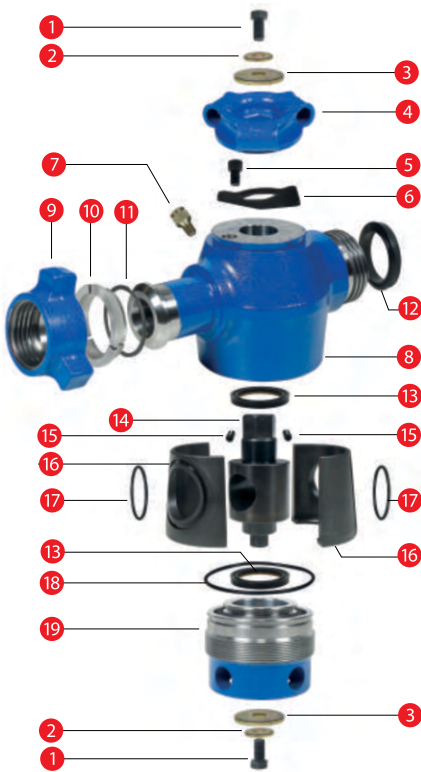

Plug Valve

NO	Item	Q'ty
Ass'y	Plug Valve 1502 HandleType	1
1	Cap Screw	2
2	Washer 1(Small)	2
3	Washer 2(Bigger)	2
4	Handle Adapter	1
5	Stop Bolt	1
6	Stop Collar	1
7	Grease Fitting	1
8	Body	1
9	Wing Nut	1
10	Segment	3
11	Retainer Ring	1
12	Lip Seal	1
13	Plug Seal	2
14	Plug	1
15	Roll Pin	2
16	Insert	2
17	Insert O-ring	2
18	Adjusting Nut O-ring	1
19	Adjusting Nut	1



Plug Valve Repair Kit

NO	Item	Q'ty
-	Repair kit Set	-
13	Plug Seal	2
14	Plug	1
16	Insert	2
17	Insert O-ring	2
18	Adjusting Nut O-ring	1

Seal Kit Contains No. 13, 17 and 18.

Size	End Connection	Service	Working Pressure	Test Pressure	Operation type	Dimensions (Inch)				
						A	B	C	D	E
2x1	1502 MxF	Standard	15,000	22,500	Handle	10.53	4.74	4.50	4.50	1.00
		H ₂ S	10,000	15,000						
2x2	LP Thread	Standard	10,000	15,000	Handle	8.50	5.41	5.25	6.85	2.05
	1502 MxF	Standard	15,000	22,500						
		H ₂ S	10,000	15,000						
	13.88	5.41	5.26	6.85						
3x3	1502 MxF	Standard	15,000	22,500	Gear	17.00	7.20	-	9.06	3.05
		H ₂ S	10,000	15,000	Handle					

* Each size can be changed as customer's requirements.

Choke Valves



2" 1502 Positive Choke Valve

- 2" Fig 1502 MxF with 3/4" or 1" Orifice and 3" Fig 1502 MxF with 2" Orifice.
- Standard service is used up to 15,000psi and tested at 22,500psi
- H2S service is used up to 10,000psi and tested at 15,000psi
- Hammer Union End Connection
- Forged alloy steel body, stainless steel and tungsten carbide parts
- Parts are interchangeable with major brands
- Suitable for a broad range of applications including wellheads, well testing, stream injection, choke and kill manifolds and well clean operations, etc.

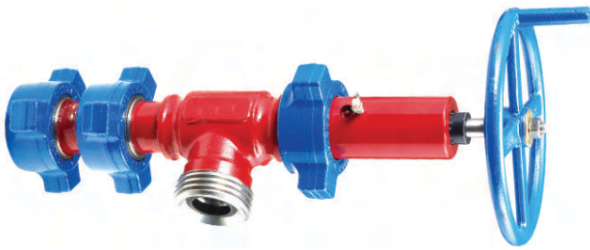

2" 1502 Adjustable Choke Valve



3" 1502 Adjustable Choke Valve

2" Positive Choke Valve



2" Positive Choke Valve

NO	Item	Q'ty
Ass'y	Positive Choke Valve 1502	1
13	Wing Nut	3
14	Lip Seal	2
15	Choke Body	1
16	Plug Stem	1
17	Stem Cap	1
18	Retainer Ring	2
19	Segment	6
20	Choke Bean	1
21	Choke Saver	1
22	Blind Male Sub	1

2" Positive Choke Valve Repair Kit

NO	Item	Q'ty
20	Choke Bean	1

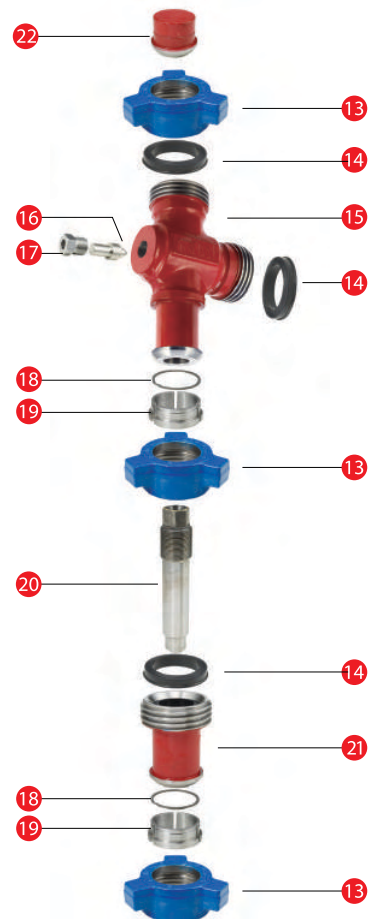

2" Adjustable Choke Valve

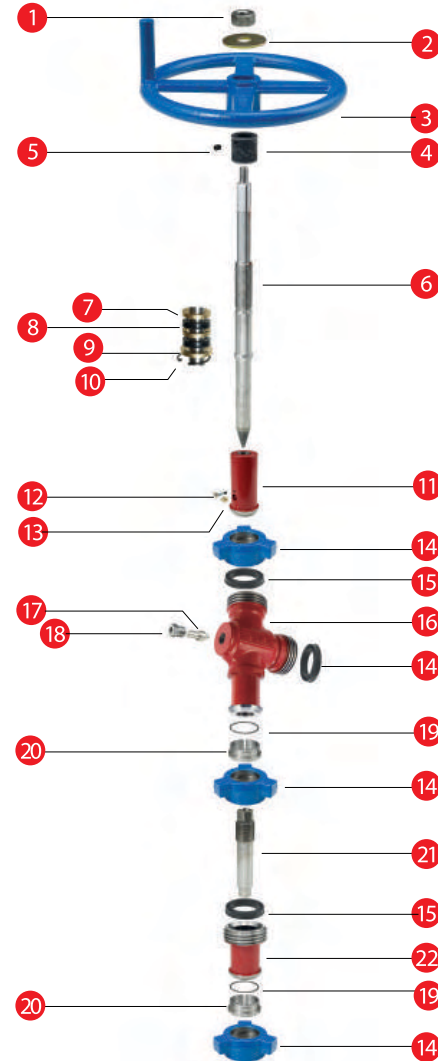
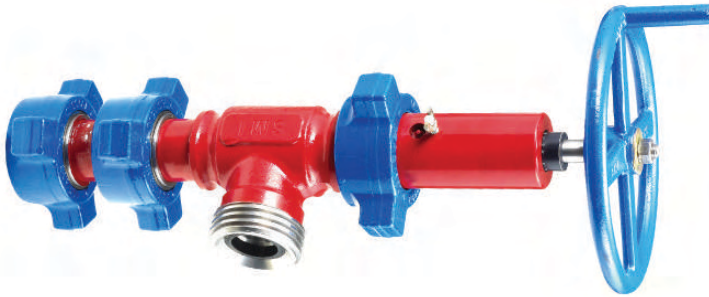

2" Adjustable Choke Valve

NO	Item	Q'ty
Ass'y	Adjustable Choke Valve 1502	1
1	Stem Nut	1
2	Washer	1
3	Hand Wheel	1
4	Indicator	1
5	Lock Screw	1
6	Choke Stem	1
7	Stem Guide	2
8	Stem Seal	2
9	Junk Ring	1
10	Snap Ring	1
11	Choke Bonnet	1
12	Thumb Screw	1
13	Grease Fitting	1
14	Wing Nut	3
15	Lip Seal	2
16	Choke Body	1
17	Plug Stem	1
18	Stem Cap	1
19	Retainer Ring	2
20	Segment	6
21	Choke Seat	1
22	Choke Saver	1

2" Adjustable Choke Valve Repair Kit

NO	Item	Q'ty
-	Repair Kit Set	-
7	Stem Guide	2
8	Stem Seal	2
9	Junk Ring	1
10	Snap Ring	1

* Each size can be changed as customer's requirements.

3" Adjustable Choke Valve



3" Adjustable Choke Valve

NO	Item	Q'ty
Ass'y	Adjustable Choke Valve 1502	1
1	Stem Nut	1
2	Washer	1
3	Hand Wheel	1
4	Indicator	1
5	Lock Screw	1
6	Choke Stem	1
7	Outsider O-ring	2
8	Seal Piston	1
9	Inside O-ring	2
10	Stem Seal	1
11	Snap Ring	1
12	Bonnet Bolt	2
13	Thumb Screw	1
14	Bonnet Extension	1
15	Choke Bonnet	1
16	Bonnet O-ring	1
17	Bonnet Back Up Ring	1
18	Wing Nut	2
19	Lip Seal	1
20	Choke Seat	1
21	Choke Body	1
22	Plug Stem	1
23	Stem Cap	1
24	Retainer Ring	1
25	Segment	3
26	Grease Fitting	1

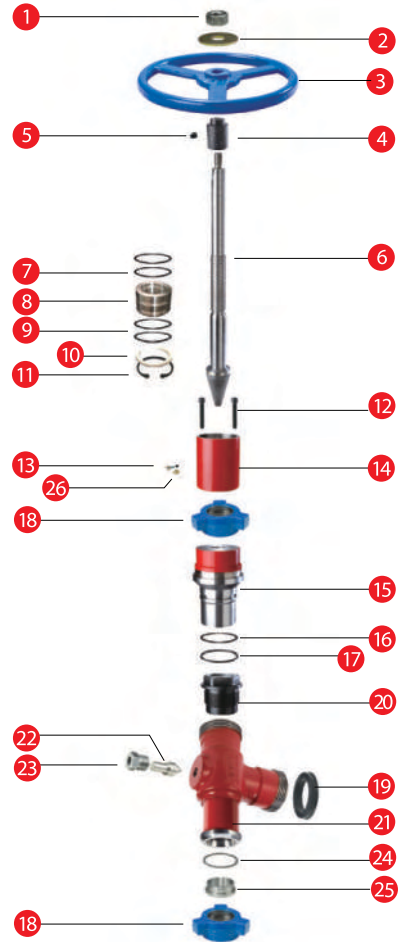

3" Adjustable Choke Valve Repair Kit

NO	Item	Q'ty
-	Repair Kit Set	-
7	Outsider O-ring	2
8	Seal Piston	1
9	Inside O-ring	2
10	Stem Seal	1
11	Snap Ring	1
16	Bonnet O-ring	1
17	Bonnet Back Up Ring	1

* Each size can be changed as customer's requirements.

API 6A Adjustable Choke Valves

Features:

- Long life and low maintenance.
- Body to bonnet contact behind the O-ring seal eliminates bonnet seal extrusion.
- A locking device is set on stem.
- Ideal for many flow regulating services and easily convertible to a positive choke.
- The stem of adjustable choke are made of high strength alloy steel. The materials have the feature of abrasion resistance, erosion resistance and reliable serviceability.
- The valve and seat can be removed by hand, without special tools and without removal of the valve body from the line, by simply removing the bonnet.

Specifications:

• Basic Design and Test	API-6A	ANSI
• Working Pressure	2000, 3000, 5000, 10000, 15000, 20000 (Psi)	400, 600, 900, 1500, 2500 (LB)
• Main Nominal Size(in)	N60, N62, 1-13/16, 2-1/16, 2-9/16, 3-1/16, 3-1/8, 4-1/16	2, 2-1/2, 3, 4, 6, 8
• Product Specification Level	PSL1, PSL2, PSL3, PSL4	PSL1, PSL2, PSL3, PSL4
• Performance Requirement Level	PR1, PR2	PR1, PR2
• Material Class	AA, BB, CC, DD, EE, FF	AA, BB, CC, DD, EE, FF
• End Connection	Flanged, Thread, Flanged and Thread	Flanged, Weld

Parts List

No	Name	Material
1	O-RING	VITON-B
2	SEAT	AISI 4135
3	DRAIN FITTING	AISI 4140
4	MALE ADAPTER	ASTM A182 F6a
5	V-PACKING	VITON
6	FEMALE ADAPTER	ASTM A182 F6a
7	WING NUT	AISI 4130
8	STEM	AISI 4135
9	HANDWHEEL	ASTM 47
10	INDICATOR	CARBON STEEL
11	LUBRICATOR	CARBON STEEL
12	BONNET	AISI 4130
13	O-RING	VITON-B
14	BODY	AISI 4130

Other trim and body material are available upon request.

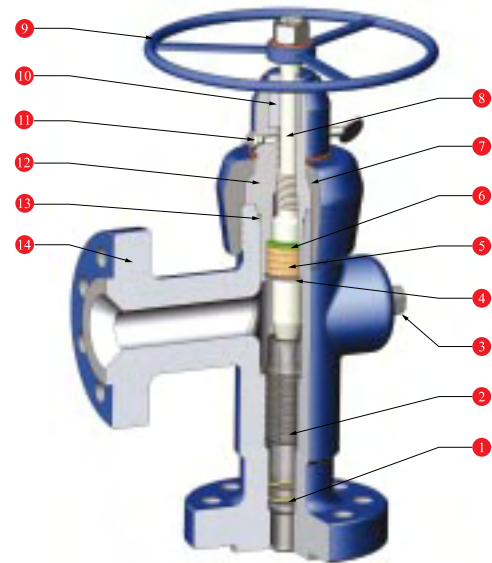

API 6A Positive Choke Valves

Features:

- Body to bonnet contact behind the O-ring seal eliminates bonnet seal extrusion.
- The bean of positive choke are made of ceramic or hard alloy steel. Both have the feature of abrasion resistance, erosion resistance and reliable serviceability.
- Flow bean chamfers are available from 2/64" to 64/64", in 1/64" increments for precise regulation of flow rate.
- The choke bean may be dismantled quickly for change of beans.

Specifications :

• Basic Design and Test	API-6A
• Working Pressure (Psi)	2000, 3000, 5000, 10000, 15000, 20000
• Main Nominal Size (in)	1-13/16, 2-1/16, 2-9/16, 3-1/16, 3-1/8, 4-1/16
• Product Specification Level	PSL1, PSL2, PSL3, PSL4
• Performance Requirement Level	PR1, PR2
• Material Class	AA, BB, CC, DD, EE, FF
• End Connection	Flanged, Thread, Flanged and Thread

Parts List

No	Name	Material
1	O-RING	VITON-B
2	SEAT	AISI 4135
3	BODY	AISI 4135
4	DRAIN FITTING	AISI 4140
5	WING NUT	AISI 4130
6	O-RING	VITON-B
7	BONNET	AISI 4135
8	GLAND RING	ALLOY STEEL

Other trim and body material are available upon request.

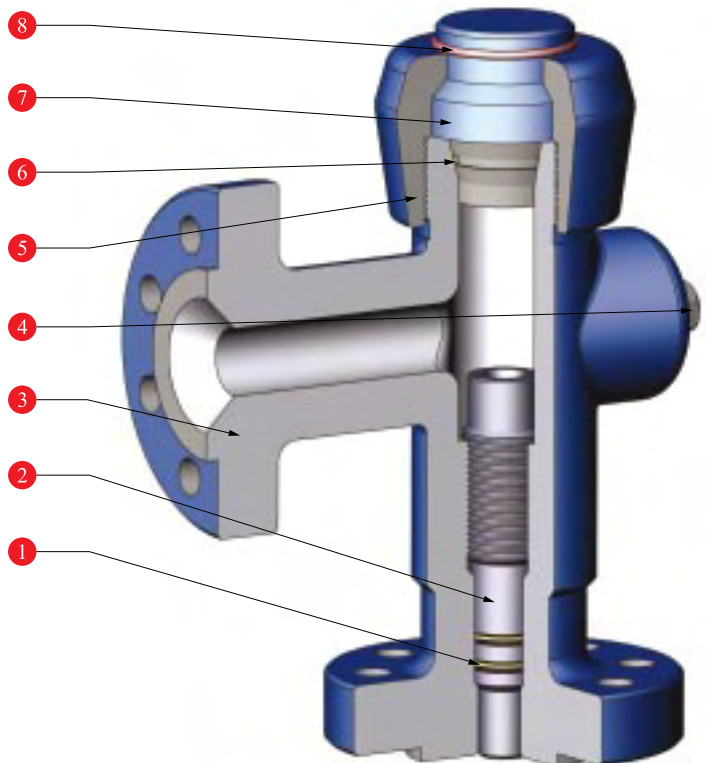

Seat & Stem

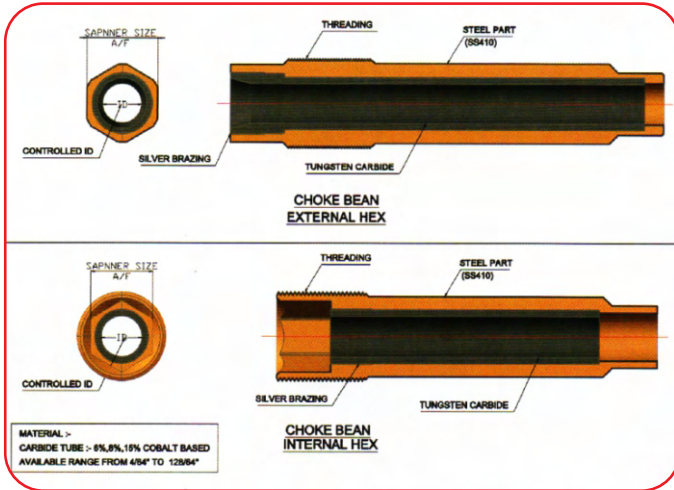

A choke is used to control the flow of fluids and is usually mounted on or close to the christmas tree. High pressure gas/oil, with abrasive sand minerals pass through these chokes at high speed causing a rapid wear. BHT Bean Chokes have steel housings which may be nitrided and are lined with Tungsten Carbide or Zirconia Ceramic inserts, to protect them from corrosive, erosive and abrasive wear.

BHT Bean Chokes are exported all over the world and are known for their international standards. BHT manufactures a wide range of bean chokes to match 'OCT' Type FC140, 'Thronill Craver', 'Gray Tool', 'Cameron' & custom made types. These are mated with a precise diameter seat that forms the choke, through which all the abrasive/ corrosive fluids must pass. Beans are available in complete range of sizes (4/64 to 128/64) generally identified by the choke diameter stated in 64th of an inch. BHT offers Tungsten Carbide / Zirconia lined choke beans & Tungsten Carbide stems for the above makes, other custom designed flanged positive chokes, threaded adjustable chokes & stems/ seats.

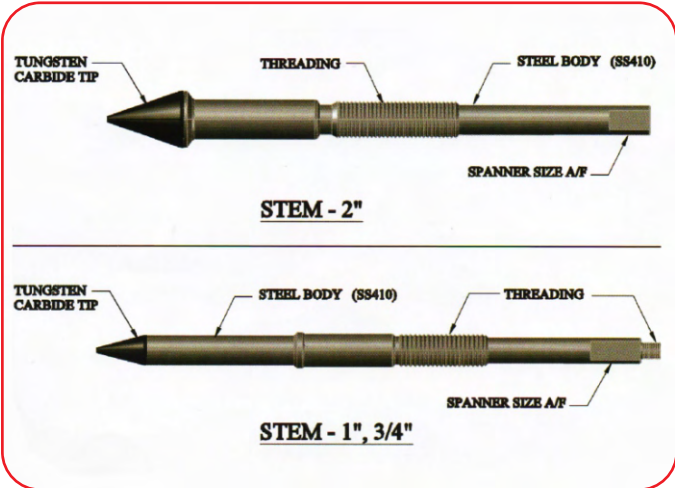

H2 Choke Valve Material Recommendations

API MATERIAL CLASS	Body	Bonnet	Choke Trim (Stem, Seat, Bean)
AA & BB General Service	Alloy steel	Alloy steel	Stainless steel or stainless steel and tungsten carbide
CC Non-Sour, High CO ₂	Stainless steel	Stainless steel	Stainless steel or stainless steel and tungsten carbide
DD & EE- 0.5 Sour, Low CO ₂ †	Alloy steel	Alloy steel	Stainless steel and tungsten carbide
FF - 0.5 Sour, High CO ₂ †c	Stainless steel	Stainless steel	Stainless steel and tungsten carbide
HH High H ₂ S, High CO ₂ †	Corrosion resistant alloy	Corrosion resistant alloy	Corrosion resistant alloy and tungsten carbide

*In compliance with NACE Standard MR-01-75

Tungsten Carbide - Seat & Assembly

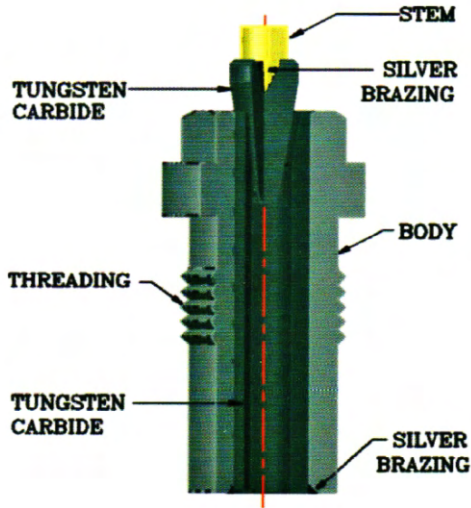

H2 Choke Valve Available Sizes and Pressures

NOMINAL SIZE, IN	Available Needle/Max. Orifice Size, in	Pressure Range, psi
2	1	2,000–10,000
2	1	15,000
3	2	2,000–10,000
4	3	2,000–5,000

Various Types of Choke Bean

