

FC4225

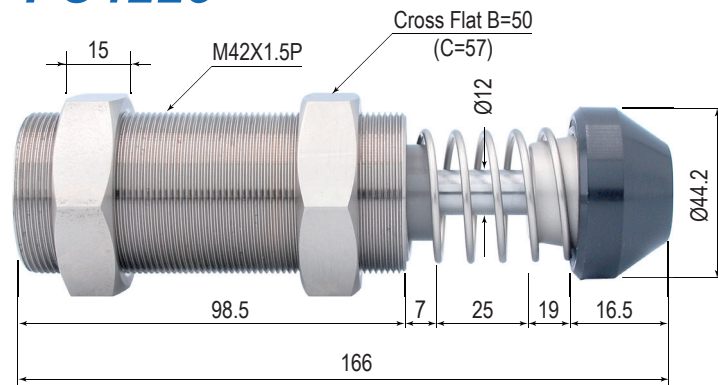

FC4250

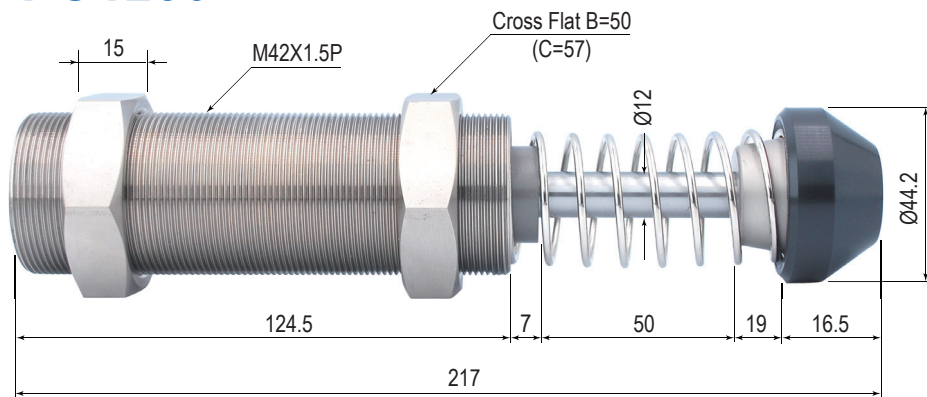

FC4275

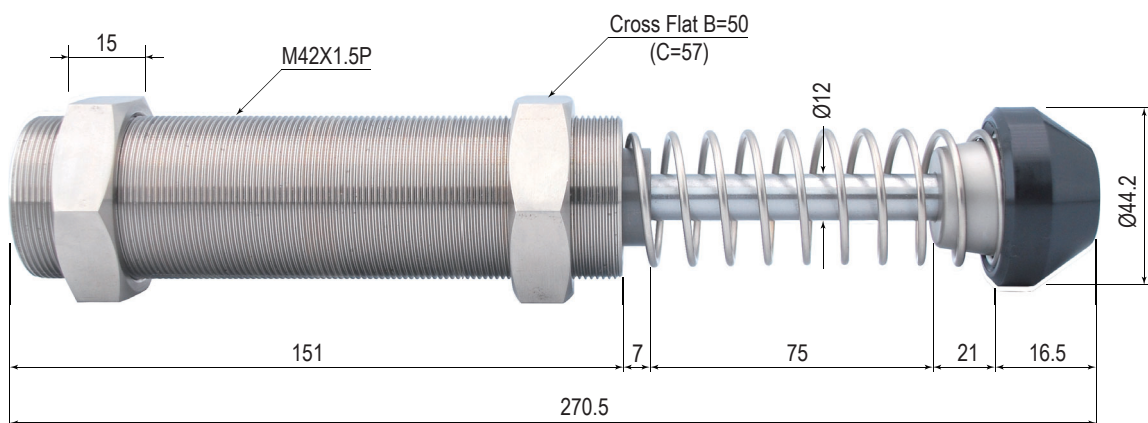

型號 MODEL	螺牙 THREAD	行程 STROKE mm	最大吸收能量 MAX NM PER CYCLE (NM)	有效重量值 EFFECTIVE MAX WE (KG)	容許速度 MAX IMPACT SPEED (M/S)	每小時吸收能量 MAX NM PER HOUR (NM)	復歸彈力 RETURN FORCE N	操作溫度 OPERATING TEMP °C
FC 4225	M42 x 1.5	25	260	58 ~ 5778	3	124,800	70 ~ 110	-10 ~ 70
FC 4250	M42 x 1.5	50	520	85 ~ 8490	3.5	156,000	70 ~ 140	-10 ~ 70
FC 4275	M42 x 1.5	75	780	108 ~ 9750	3.8	187,200	60 ~ 160	-10 ~ 70