

STANDARDS

VALVE DESIGN	: PN 16
END CONNECTIONS	: TO SUIT FLANGE DIMENSIONS AS PER ASA 150, H TABLE, PN 16
PRESSURE & TEMP. RATINGS FOR	MAX. OPERATING 16 BAR g
SOFT SEATS	: MAX. OPERATING TEMP. 260°C MINI. OPERATING TEMP. -175°C HYDRAULIC TEST PRESSURE 24 BAR

Check Valve Disc Type

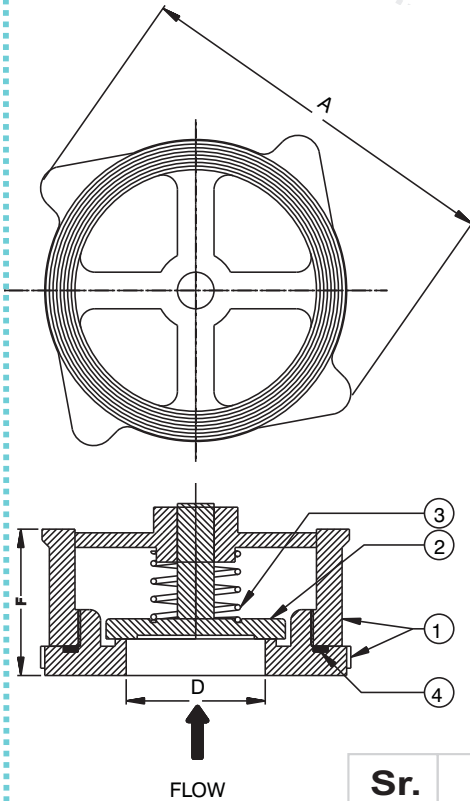

Sr.	Parts Name	Material Specifications
1	Body	ASTM A 351 CF8/ CF8M
2	Plug	AISI 304/316
3	Spring	Stainless Steel
4	Seal	PTFE Ring / Viton

SIZE	MM	15	20	40	40	50	80	100
	INCH	ø1/2"	ø3/4"	ø1"	ø1.5"	ø2"	ø3"	ø4"
F		25	30	35	40	45	58	65
D		15	20	25	38	50	75	100
A		62	72	85	103	127	157	157

SEATING OPTIONS CAN BE PROVIDED AS PER THE REQUIRED SERVICE CONDITIONS
FACE TO FACE DIMENSIONS AS PER MANUFACTURER STANDARD

Note : Standard Material Specifications Can Be Changed According To Service Condition

SAHAJANAND
VALVES PVT LTD



GATE
VALVE

GLOBE
VALVE

CHECK
VALVE

BALL
VALVE

FILTER
VALVE

STRAINERS Y
TYPE VALVE



[CONTACT US](#)

[GO TO](#)

