

KST®

Pneumatic Actuator BT Series



Company Introduction

KST Valve Group Co., Ltd. is integrated by research & development, production and marketing. The R&D is based in Beijing (Beijing DEKON), sales center is in Shanghai (Shanghai Kangsaite Fluid Co., Ltd.), production basement is located in a coastal city, Wenzhou.

KST Valve Group is dedicating into the development and application of valve and valve automatic control, intelligent control system. By adopting the advanced technology and craftsmanship from United States, based on the R&D team of No. 5 Research Center of Beijing University of Aeronautics and Astronautics (BUAA), KST has already developed and produced many high-quality new products applied in fluid control filed.

KST Valve Group's R&D center is based in Beijing. The BUAA R&D Team under the leadership of famous professor, Doctor. Dong Quanlin, is the technical core of KST Valve Group. KST is equipped with advance CNC center, lathe and many finishing equipment, uses CIMS Information Management System, and production is arranged strictly based on ISO9001 Quality Standard System, so that product standardization and quality stability can be guaranteed. KST has many cutting-edge test equipment, such as valve performance test equipment, valve service life test board, valve pressure test board, torque tester, actuator service life test equipment, surface roughness meter, spectrometer, etc. KST is proud to have a group of professional sales engineer who can provide their best service and best products based on clients' application requirement, as well as after-sales technician, who can provide on-side technical support for client.



KST Valve Group Co., Ltd.

BTD / BTS series of new valve pneumatic actuator

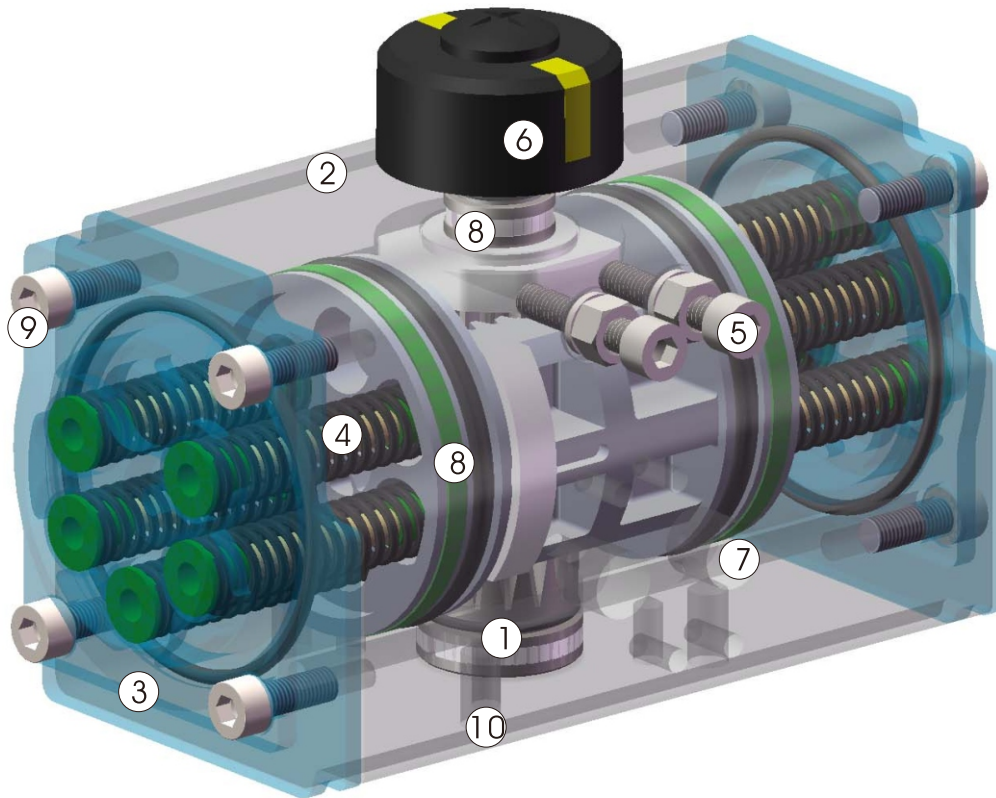

BTD/BTS new rack and pinion pneumatic actuator by the zhejiang KST company combines the latest technology at home and abroad, through the three-dimensional model of innovation and optimization of CAD design, beautiful shape compact, modern styling; and adopt practical new materials, new processes, so that the product quality, more reliable; more standard selection of more affordable; products fully meet the latest international standards, technical specifications, to meet current and future needs.

- ① dual piston rack and pinion design of symmetric structures, rapid and smooth movement, high precision, high output power by a simple change in the direction of the piston assembly positions available anti-rotation.
- ② high quality extruded aluminum alloy cylinder block, by precision machining the hole and the external surface of hard anodized (anodic oxidation under special circumstances + Teflon coating), longer life, low friction coefficient.
- ③ integrated design, all the double acting and single-function actuator models have the same cylinder and end caps, easily removed by installing a spring or spring to change the mode of action.

- ④ combined pre-spring break Hean whole group, whether in the assembly process or use on-site in both convenient and safe to install or change the
- ⑤ the external side of the two single independent adjustment screw has been number of springs. installed in the valve for the actuator is precisely to facilitate, control valve open and valve closed position, For the whole trip conditioned office is also configured in two cover a longer adjustment screws.
- ⑥ multi-position indicator, on-site visual instructions, consistent with VDI/VDE3845, NAMUR standard slot, the output can be installed and all the accessories, such as limit switch box, electric positioner, position sensor (Pepperl and Fuchs, Turck).
- ⑦ gas source interface line NAMURstandard, direct safety plaquesNAMUR standard solenoid valve.
- ⑧ rack on the back of the composite bearing and piston guide ring and the output shaft bearings to prevent metal on metal friction and increasing lubrication, so a low friction, long life.
- ⑨ All fasteners are stainless steel, long-term corrosion resistance.
- ⑩ connection part of the line with new international standard ISO5211, DIN3337 (F03-F25) makes products with interchangeable, versatile.

Model preparation

BT-160 S-K10 F10/12 P27-90-B-A

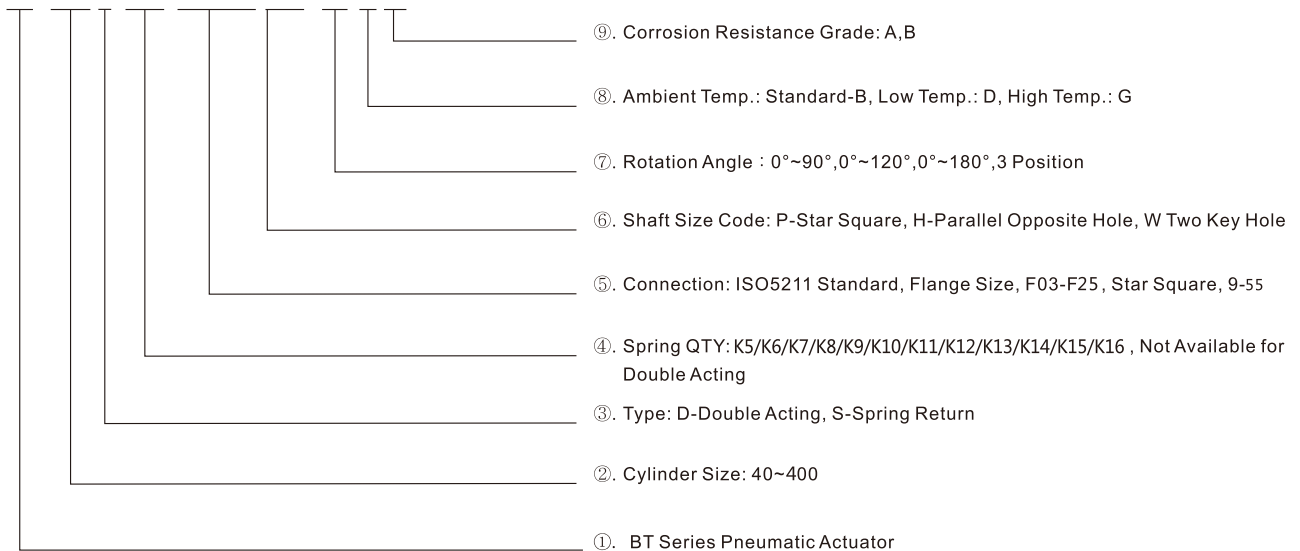

Components and materials, corrosion

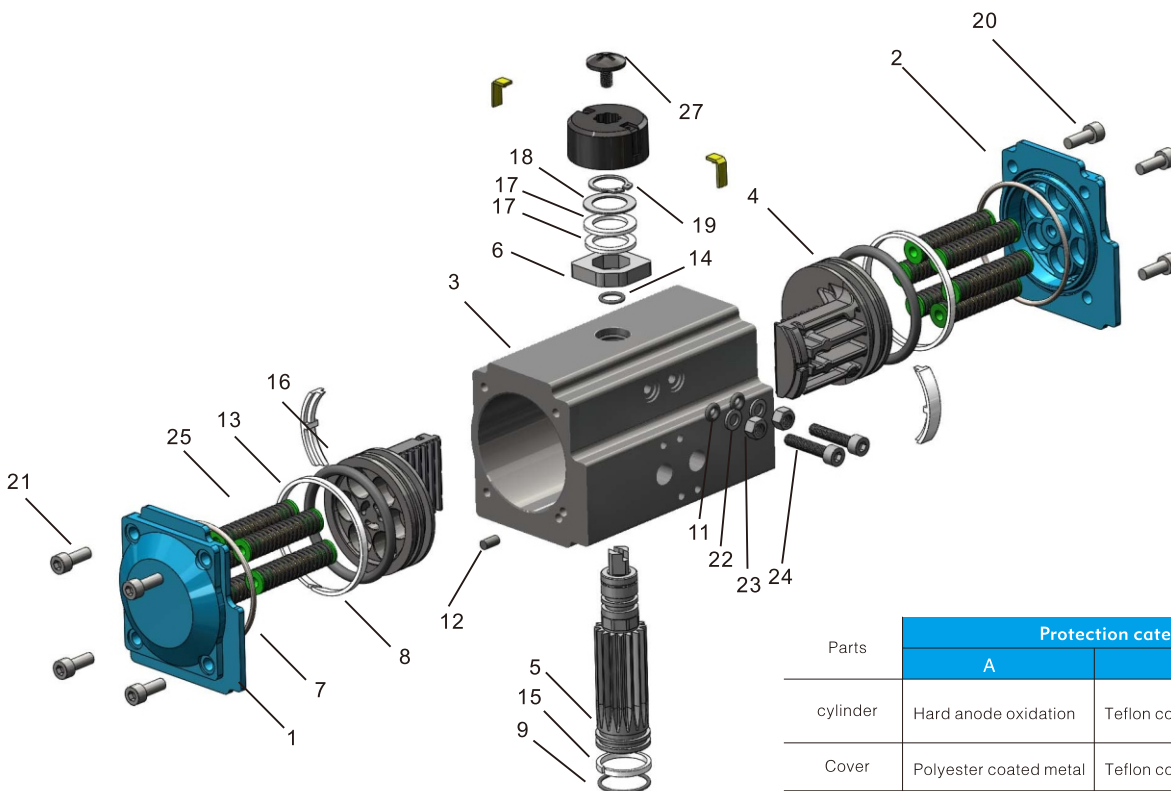

Parts	Protection category	
	A	B
cylinder	Hard anode oxidation	Teflon coating+ Anode sclerosis
Cover	Polyester coated metal	Teflon coating
Output shaft	Carbon steel electroless nickel plating	Electroless nickel plating or stainless steel
Use Occasion	General situation	General occasions or low concentrations of acidic environment

Pneumatic Actuator BT Series

Part Number	Each number	Part Name	Standard Materials	Selected materials
01	1	Left Cover	Aluminum Die Casting	Stainless steel
02	1	Right Cover	Aluminum Die Casting	Stainless steel
03	1	body	Aluminum extrusion	Stainless steel
04	2	Piston	Aluminum Die Casting	----
05	1	Output shaft	Carbon Steel	Stainless steel
06	1	Cam adjustment	Stainless steel	----
07 *	2	O-ring (cover)	NBR	Fluorine or silicone rubber
08 *	2	O-ring (Piston)	NBR	Fluorine or silicone rubber
09 *	1	O-ring (output shaft bottom)	NBR	Fluorine or silicone rubber
10 *	1	O-ring (output shaft at the top)	NBR	Fluorine or silicone rubber
11 *	2	O-ring (adjusting screw)	NBR	Fluorine or silicone rubber
12 *	2	Plug (Cylinder)	NBR	Fluorine or silicone rubber
13 *	2	Bearing (Piston)	POM	----
14 *	1	Bearing (output shaft at the top)	POM	----
15 *	1	Bearing (output shaft bottom)	POM	----
16 *	1	Guide with Bearing (Piston back)	POM	----
17 *	2	Thrust bearings (output shaft)	POM	----
18	2	Gasket (output shaft)	Stainless steel	----
19	1	Flexible file ring	Spring steel	----
20	4	Cover bolt	Stainless steel	----
21	4	Cover Gasket	Stainless steel	----
22	2	Gasket	Stainless steel	----
23	2	Nut	Stainless steel	----
24	2	Adjustment bolt	Stainless steel	----
25	5-12	Spring Components	Alloy spring steel	----
26	1	Position indicator	POM	----
27	1	Screw of indicator	POM	----

Torque Diagram

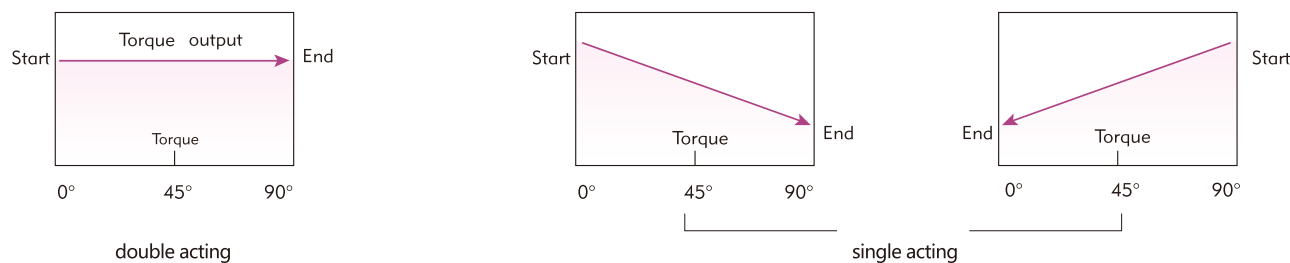

Double Acting Operation

Selection of double action actuators

The suggested safety factor for double acting actuators under normal working conditions is 20%-30%

Example:

- The torque needed by valve = 100 N.m
- The torque considered safety factor $100 \times (1 + 30\%) = 130 \text{ N.m}$
- Air Supply = 5 Bar

According to double acting torque table, we can choose the minimum model is BT-105D.

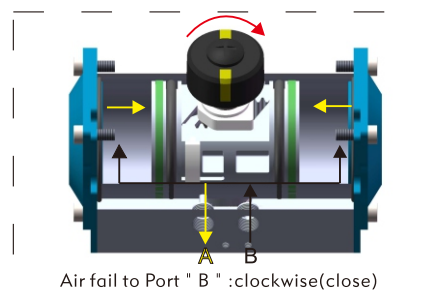

Pneumatic Actuator BT Series

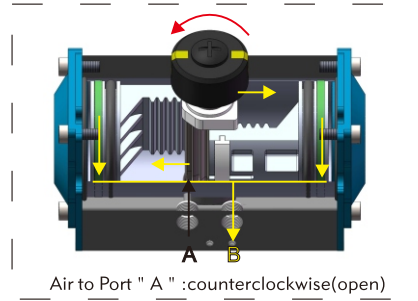
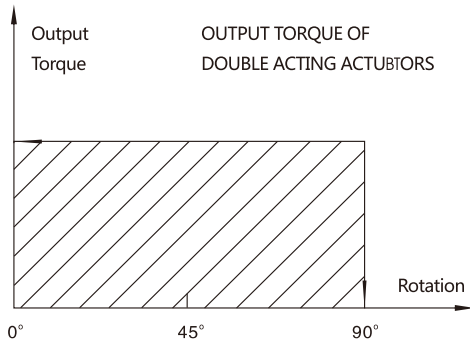

* Pistons must be inverted to reverse actuator rotation

Spring Return Operation

Selection of single action actuators

Under normal operating conditions, a single actuator to consider the role of the safety factor of 30% -50%.

For example:

Valve required torque = 100N.m

Safety torque = $100 \times (1 + 30\%) = 130\text{N.m}$

according to single acting actuator output torque table, we can find BT-140SK10

Torque following

Implementation process $0^\circ = 216.8\text{N.m}$ air

Implementation process $90^\circ = 175.8\text{N.m}$ air

Spring stroke $0^\circ = 172\text{N.m}$

Spring stroke $90^\circ = 258\text{N.m}$

output Torque bigger than all our needs

Note:

Single action during the spring return actuators, actuator B hole ventilation does not affect actuator output torque.instead it`s helpful of spring return

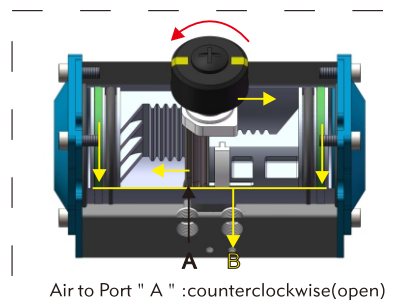
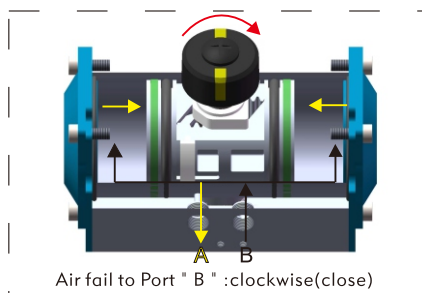

* Spring force makes the actuator clockwise when the air is exhausted at port " A "

* When air fail to counterclockwise is required, the pistons must be inverted

Pneumatic Actuator BT Series

Double Acting Actuator Output Torque(Nm)

Model	Air supply pressure(Unit:Bar)								
	3bar	3.5bar	4bar	4.5bar	5bar	5.5bar	6bar	7bar	8bar
BT- 40D	5.7	6.7	7.6	8.6	9.5	10.5	11.4	13.3	15.2
BT- 52D	12.0	14.0	16.0	18.0	20.0	22.0	24.0	28.0	32.0
BT- 63D	21.0	24.5	28.0	31.5	35.0	38.5	42.0	49.0	56.0
BT- 75D	30.0	35.0	40.0	45.0	50.0	55.0	60.0	70.0	80.0
BT- 83D	45.7	53.3	61.0	68.6	76.2	83.8	91.4	106.7	121.9
BT- 92D	67.4	78.7	89.9	101.2	112.4	123.6	134.9	157.4	179.8
BT-105D	97.6	113.9	130.2	146.4	162.7	179.0	195.2	227.8	260.3
BT-125D	152.2	177.6	203.0	228.3	253.7	279.1	304.4	355.2	405.9
BT-140D	260.3	303.7	347.0	390.4	433.8	477.2	520.6	607.3	694.1
BT-160D	396.6	462.7	528.8	594.9	661.0	727.1	793.2	925.4	1057.6
BT-190D	639.3	745.9	852.4	959.0	1065.5	1172.1	1278.6	1491.7	1704.8
BT-210D	781.0	911.2	1041.4	1171.5	1301.7	1431.9	1562.0	1822.4	2082.7
BT-240D	1147.6	1338.8	1530.1	1721.3	1912.6	2103.9	2295.1	2677.6	3060.2
BT-270D	1742.9	2033.4	2323.8	2614.3	2904.8	3195.3	3485.8	4066.7	4647.7
BT-300D	2390.8	2789.3	3187.8	3586.2	3984.7	4383.2	4781.6	5578.6	6375.5
BT- 350D	3580	4176	4773	5369	5966	6563	7159	8352	9546
BT- 400D	5100	5950	6800	7650	8500	9350	10200	11900	13600

Dimensional Drawing

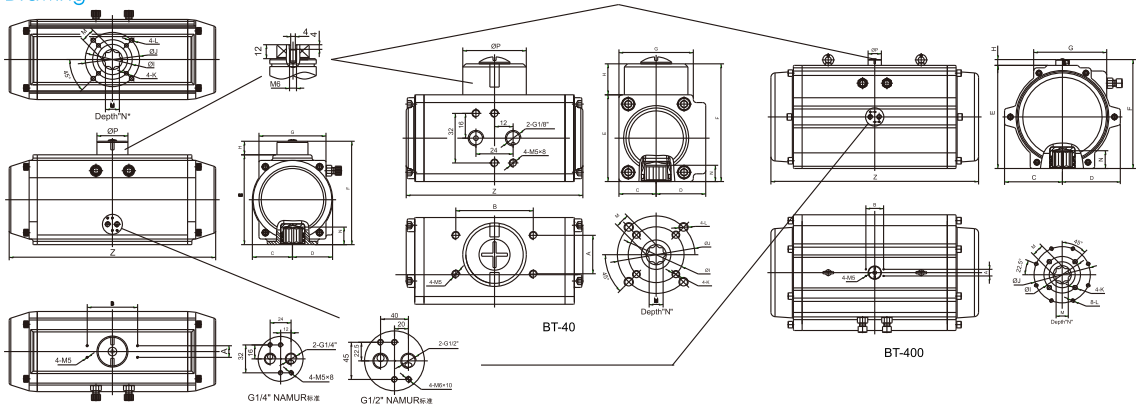

BT-52, BT-63, BT-75, BT-83, BT-92, BT-105, BT-125.
BT-140, BT-160, BT-190, BT-210, BT-240, BT-270, BT-300, BT-350

Dimension

Unit (mm)

Model	A	B	C	D	E	F	G	H	I	I-1	J	J-1	K	L	M	N	P	Z	Air
BT-40	25	50	24	32	56	76	48	20	36	F03	50	F05	M5×8	M6×10	9	10	42	110	1/8"
BT-52	30	80	30	42.5	72.4	92.4	50.5	20	36	F03	50	F05	M5×8	M6×10	11	14	42	150	1/4"
BT-63	30	80	36	47	88.5	108.5	69.5	20	50	F05	70	F07	M6×10	M8×13	14	18	42	171	1/4"
BT-75	30	80	42.5	53	100	120	78	20	50	F05	70	F07	M6×10	M8×13	14	18	42	186	1/4"
BT-83	30	80	46.5	57	109.5	129.5	86	20	50	F05	70	F07	M6×10	M8×13	17	21	42	206	1/4"
BT-92	30	80	50	58	117	137	90	20	50	F05	70	F07	M6×10	M8×13	17	21	42	265	1/4"
BT-105	30	80	57.5	64	135	155	104.5	20	70	F07	102	F10	M8×13	M10×16	22	26	42	272	1/4"
BT-125	30	80	67.5	74.5	157	187	120.5	30	70	F07	102	F10	M8×13	M10×16	22	26	62	304	1/4"
BT-140	30	80	75.5	75.5	174	204	125	30	102	F10	125	F12	M10×16	M12×20	27	32	62	395	1/4"
BT-160	30	130	87	87	198	228	143	30	102	F10	125	F12	M10×16	M12×20	27	32	80	462	1/4"
BT-190	30	130	103	103	232	262	172	30			140	F14		M16×25	36	40	80	552	1/4"
BT-210	30	130	113	113	257	287	194	30			140	F14		M16×25	36	40	90	556	1/4"
BT-240	30	130	130	130	292	322	230	30			165	F16		M20×30	46	50	90	630	1/4"
BT-270	30	130	147	147	331	361	252	30			165	F16		M20×30	46	50	90	750	1/2"
BT-300	30	130	161	172	354	384	290	30			165	F16		M20×30	46	50	90	772	1/2"
BT-350	30	130	190	190	410	440	334	30	165	F16	254	F25	M20×30	8-M16×25	46	50	90	860	1/2"
BT-400	30	130	262	262	466	496	330	30	165	F16	254	F25	M20×30	8-M16×25	55	72	90	938	1/2"

Sizing information and How to order

Single Acting Actuator Output Torque(Nm)

Model	Spring Q.ty	Air pressure																Spring Torque					
		2.5bar		3.0bar		3.5bar		4.0bar		4.5bar		5.0bar		5.5bar		6.0bar		7.0bar		8.0bar		0° Start	90° End
		0° Start	90° End	0° Start	90° End	0° Start	90° End	0° Start	90° End	0° Start	90° End	0° Start	90° End	0° Start	90° End	0° Start	90° End	0° Start	90° End				
BT-350S	5	1810	1281	2407	1878	3003	2474	3600	3071	4196	3667	4793	4264									1702	1173
	6	1575	940	2172	1537	2768	2133	3365	2730	3961	3326	4558	3923									2043	1408
	7			1938	1197	2534	1793	2896	2049	3492	2645	4089	3242	4686	3839	5282	3839	6475	5628			2383	1642
	8					2299	1452	2661	1709	3257	2305	3854	2902	4451	3499	5047	3499	6240	5288	7434	6482	2724	1877
	9									3023	1964	3620	2561	4217	3158	4813	3158	6006	4947	7200	6141	3405	2346
	10											3385	2221	3982	2818	4578	2818	5771	4607	6965	5801	3745	2581
	11													3747	2477	4343	2477	5536	4266	6730	5460	4086	2816
BT-400S	7	2413	1370	3263	2220	4113	3070	4963	3920	5813	4770	6663	5620									2880	1837
	8	2150	958	3000	1808	3850	2658	4700	3508	5550	4358	6400	5208	7250	6058							3292	2100
	9	1888	547	2738	1397	3588	2247	4438	3097	5288	3947	6138	4797	6988	5647	7838	5647					3703	2362
	10	1626	135	2476	985	3326	1835	4176	2685	5026	3535	5876	4385	6726	5235	7576	5235	9276	7785			4115	2624
	11			2213	574	3063	1424	3913	2274	4763	3124	5613	3974	6463	4824	7313	4824	9013	7374	10713	9074	4526	2887
	12					2801	1012	3651	1862	4501	2712	5351	3562	6201	4412	7051	4412	8751	6962	10451	8662	4938	3149
	13							3388	1451	4238	2301	5088	3151	5938	4001	6788	4001	8488	6551	10188	8251	5349	3412
	14									3976	1889	4826	2739	5676	3589	6526	3589	8226	6139	9926	7839	5761	3674
	15											4563	2328	5413	3178	6263	3178	7963	5728	9663	7428	6172	3937
	16													5151	2766	6001	2766	7701	5316	9401	7016	6584	4199

Sizing information and How to order

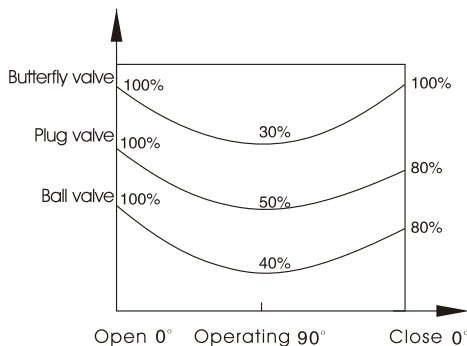

Forexample:

Butterfly of the original maximum torque=80N.m

Opened torque $80 \times 30\% = 24\text{N.m}$

Airpressure=5Bar

We can choose BT-125SK10

Air travel $0^\circ = 148.7\text{N.m} > 80\text{N.m}$

Air travel $90^\circ = 96.7\text{N.m} > 24\text{N.m}$

Spring stroke $90^\circ = 157\text{N.m} > 24\text{N.m}$

Spring stroke $0^\circ = 105\text{N.m} > 80\text{N.m}$

The above figures show opening meet of the butterfly valve

Operating type (Double acting and spring return)

Air supply connection is designed in accordance with NAMUR Standard to install solenoid valves.



The Namur drive pinion and the Namur top mounting connection permit direct installation of accessories such as limit switch box and positioner.



Bottom mounting connection is designed in accordance with ISO5211, DIN3337 standards for direct mounting with valve gear boxes or mounting brackets.

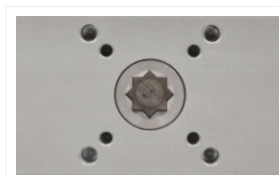

Operating conditions:

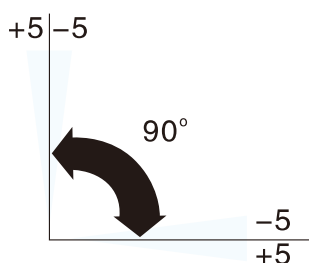

- Operating media
Dry or lubricated air, or the non-corrosive gases
The maximum particle diameter must less than $30\ \mu\text{m}$
- Air supply pressure
The minimum supply pressure is 2.5 Bar
The maximum supply pressure is 8 Bar
- Operating temperature
Standard: $-20^\circ\text{C} \sim +80^\circ\text{C}$
Low temperature: $-40^\circ\text{C} \sim +80^\circ\text{C}$
High temperature: $-15^\circ\text{C} \sim +150^\circ\text{C}$
- Travel adjustment
Have adjustment range of $\pm 5^\circ$ for the rotation at 0° and 90°
- Application
Either indoor or outdoor

Air Consumption

Air Consumption

Model	Maximum pressure	The angle of rotation	Temperature	1 st the need to adjust the number of laps	Diameter	Internal volume		On-off time		Weight	
						close	Open	close	Open	A weight	Spring weight
BT-52S	Lubrication or dry of compressed air 8bar	(0°-90°) ± 5° or full itinerary 0°-90°	B (normal) NBR O-ring -20~+80°C G (High Temperature) Viton O-ring -15~+150°C D (Low Temperature) Silicone O-ring -40~+80°C	1/6	52	0.1	0.2	DA 0.6 SR 2.0	DA 0.6 SR 0.5	DA 1.30 SR 1.42	... 0.0095
BT-63S				1/6	63	0.2	0.3	DA 0.7 SR 2.0	DA 0.7 SR 1.0	DA 2.05 SR 2.25	... 0.0135
BT-75S				1/5	75	0.3	0.5	DA 0.8 SR 2.0	DA 0.7 SR 1.0	DA 2.65 SR 2.95	... 0.0210
BT-83S				1/5	83	0.5	0.8	DA 0.9 SR 2.5	DA 0.8 SR 1.0	DA 3.30 SR 3.70	... 0.0365
BT-92S				1/5	92	0.7	1.1	DA 1.0 SR 3.0	DA 1.0 SR 1.0	DA 4.55 SR 5.30	... 0.0600
BT-105S				1/4	105	1.2	1.8	DA 1.5 SR 3.0	DA 1.5 SR 1.0	DA 5.80 SR 6.70	... 0.0730
BT-125S				1/4	125	1.5	2.3	DA 2.0 SR 4.0	DA 2.0 SR 1.0	DA 8.95 SR 10.35	... 0.1100
BT-140S				1/4	140	2.4	3.8	DA 2.5 SR 4.0	DA 2.5 SR 1.0	DA 13.35 SR 15.35	... 0.1865
BT-160S				1/4	160	3.1	4.9	DA 4.0 SR 4.0	DA 3.0 SR 1.5	DA 19.20 SR 23.10	... 0.2695
BT-190S				1/4	190	4.5	7.3	DA 5.0 SR 5.0	DA 4.0 SR 3.0	DA 31.05 SR 36.80	... 0.4792
BT-210S				1/4	210	6.8	11.2	DA 5.0 SR 6.0	DA 5.0 SR 3.0	DA 39.00 SR 45.50	... 0.5001
BT-240S				1/4	240	10	15.2	DA 6.0 SR 12	DA 6.0 SR 4.0	DA 53.00 SR 64.00	... 0.9167
BT-270S				1/4	270	14.5	21.4	DA 8.0 SR 15	DA 8.0 SR 6.0	DA 76.00 SR 95.20	... 1.6000
BT-300S				1/4	300	23.8	29.7	DA 12 SR 18	DA 12 SR 8.0	DA 100.0 SR 128.2	... 2.3500
BT-350S				1/4	350	35.1	46	DA 14 SR 20	DA 14 SR 10	DA 186.0 SR 216.0	... 2.5001
BT-400S				1/4	400	52.6	56	DA 15 SR 25	DA 15 SR 12	DA 243.0 SR 279.0	... 3.0001

Air consumption rest with Supply. Air volume and Action cycle times, expressions

$$L/Min = \text{Air volume}(\text{Air volume Opening} + \text{Air volume closing}) \times [(\text{Air Supply}(\text{Kpa}) + 101.3) \div 101.3] \times \text{Action cycle times}(\text{min})$$

Common faults and inspection, troubleshooting

Failure phenomenon	Inspection Items	Solution
Pneumatic valve can not move	1, the electromagnetic valve is normal, coil is burned, Electromagnetic valve is stuck being stolen	Solenoid valve replacement, replacement coils, remove stolen property.
	2, a separate air supply pneumatic actuator test, check seals and Whether the cylinder is damaged.	Replace a bad ring and cylinder.
	3, there are impurities in the spool valve stuck.	Remove impurities, replace damaged parts.
	4, the handle in a manual motor location.	change the handle to pneumatic position
Slow motion, crawling	1, supply pressure is not enough.	The increase of gas supply pressure (0.4-0.7Mpa)
	2, pneumatic actuator output torque is too small.	Increase the pneumatic actuator Production.
	3, the valve spool or valve assembly too tight.	Re-assembly adjustments.
	4, air supply pipe plug, flow is too small.	Exclude plug, replace the filter cartridge.
Reply devices without signal	1, power line short circuit or open circuit.	Maintenance of power lines.
	2, reply within the cam position is not accurate.	Adjust the cam to the correct location
	3, micro switch damaged.	Replacement Micro Switch

