



Think Performance
Think of Us



High Performance Solution For
MATERIAL HANDLING EQUIPMENT

Over Head Cranes | Flame Proof Cranes & Hoist | Jib Cranes | Wire Rope Hoist



Think Performance
Think of Us

MEEKA IS ONE OF THE LEADING
MANUFACTURER AND EXPORTER OF
MATERIAL HANDLING EQUIPMENT

ABOUT US

MEEKA is one of the leading manufacturers and exporters of Material Handling Equipment since 1983, and as may be seen from the list of our valued clients, we have served many Government Organizations, Public and Private Limited Companies with our quality products. We take pride in saying that the quality of our products has been very widely accepted in domestic as well as international markets in three decades of our existence as independent manufacturing units, we have developed an efficient infrastructure to manufacture different range of Material Handling Equipment.

MEEKA is an ISO 9001-2015 company, we have a well-established workshop and office building with a facility to manufacture various Types of cranes and wire rope hoist. The company has in-house computer-aided design facility to meet the challenges of this highly competitive field.

MISSION

Meeka is committed to provide the highest quality product possible through new technologies and with our highly skilled and dedicated employees, to pursue an aggressive research and development program thus insuring its future as a leader in material handling equipment industries. We will demonstrate the highest standard of services across the globe through highly trained representatives.





“ We Give Industrial Mobility Solutions
Which Saves TIME, MONEY, EFFORTS.”



ADVANTAGES DESIGN

Our Drawing & Design office is headed by a qualified Mechanical Engineer who not only keeps strict watch over quality of each component but also constantly interacts with our valued customers to improve design to suit their requirements. All designs have been of 3D Solid Modeler with Finite Element Analysis. We also have in-house design development software. We can design and calculate all required parameters as per the standards, with the use of software.

Benefits of the same are

- ▶ Virtual model for design analysis.
- ▶ Quality products can be manufactured in shortest period of time.
- ▶ Delivery time can be reduced.
- ▶ Lighter weight of equipment.
- ▶ Saving on runway structure.
- ▶ Accurate and faster designing.

QUALITY ASSURANCE

We use strict quality plan for manufacturing our product by using various types of inspections:

- ▶ Design verification.
- ▶ Chemical & Physical testing of raw materials.
- ▶ Ultrasonic testing of raw materials.
- ▶ Inspection of Gears & Pinions on Gear Testers.
- ▶ Dimensional Controls.
- ▶ Load & Overload Testing at works, with in-house testing facility & at client site as well.
- ▶ X-ray test for welding joints.



We have also offered our product for third party inspection for various well known third party inspection agencies in India like.





We manufacture our own gear boxes, which are described further here. All the gear boxes which are used in Hoisting, L.T. and C.T. are horizontal shaft helical gear type with robust & sturdy M.S. fabricated housing. The entire gear assembly is running on anti-friction bearing. The pinions which are used in the gearbox are integral & solid one piece pinion. The gear box housings are duly stress relieved after the fabrication. The gearbox bearing sizes are machined on horizontal boring machine to ensure proper accuracy. All gears & pinions are duly hardened to withstand the heavy loads for the life span depending upon the class of application. Provision is kept for filling the lubricating oil with level indicator.

Benefits of our gear boxes

- ▶ In house Manufacturing Process makes after sales and service easy.
- ▶ Better strength and silent running
- ▶ Longer life, No misalignment
- ▶ Minimal wear
- ▶ Properly hardened
- ▶ Profile ground gear and pinion as and when required

ENGINEERING AND MANUFACTURING CAPABILITIES

- ▶ We have our own Software Company, Meeka Software Pvt. Ltd. With the help of a sister Concern, we have made an integrated ERP software system for all departments. With its use, we can track down supplied parts with our equipment, can track down past orders and inquiries. It maintains inventory to reduce delivery time.
- ▶ In-house developed software for designing of complete cranes and components.
- ▶ Solid Edge for design analysis & new designing.
- ▶ AutoCAD for drawings.
- ▶ MEEKA has a team of highly experienced and qualified engineers who work with perfection to achieve this aim. We have our own R and D department which is consistently improving on the product.
- ▶ MEEKA is using CO2 MIG welding machines for different joints for cranes and their parts. We have automated welding machine to weld box girder simultaneously.
- ▶ Strength Calculation of GEARS are preformed by software.

SHOP FLOOR

Meeka has Two Different Manufacturing Units

UNIT - 1 has
4000 square meters area.



UNIT - 2 has
10033 square meters area.



Some of our In house machinery are:

- ▶ AUTOMATIC CO2 MIG WELDING MACHINE
- ▶ HYDRAULIC MACHINE
- ▶ BANDSAW MACHINE FOR CUTTING
- ▶ WELDING MACHINES
- ▶ PORTABLE CNC CUTTING MACHINE

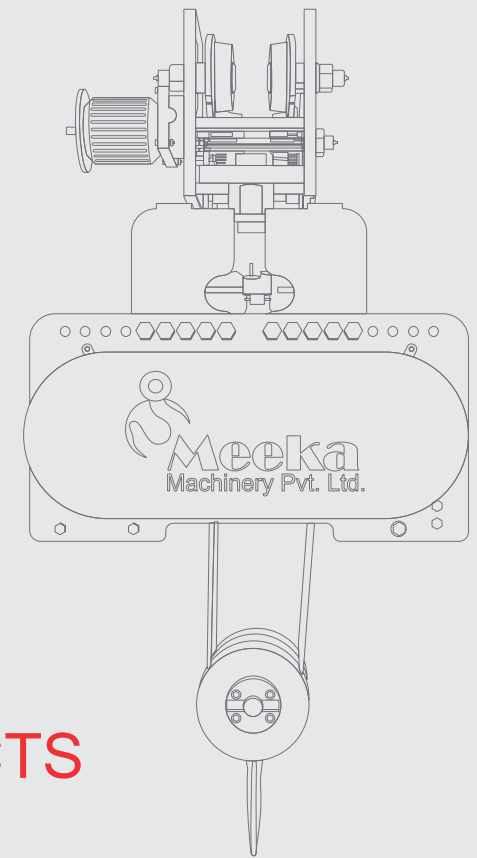

OUR PRODUCTS

- ▶ Power Travel Wire Rope Hoist
- ▶ Flame Proof Hoist
- ▶ Base Mounted Hoist
- ▶ Double Rail Type Hoist
- ▶ M.E Crab Type Hoist
- ▶ Flaxible Trolley Hoist



ESSENTIAL PARTS



Gear Box

All the gear boxes which are used in Hoisting are horizontal shaft helical gear type with robust and sturdy M.S. fabricated housing. The entire gear assembly is running on anti-friction bearing. The pinions which are used in the gearbox are integral and solid one piece pinion. The gearbox bearing sizes are machined on horizontal boring machine to ensure proper accuracy. All gears and pinions are duly hardened to withstand the heavy loads for the life span depending upon the class of application. Provision is kept for filling the lubricating oil with level indicator.



Hoist Brake

The hoist motor is fitted within electromagnetic brake of shoe/disc type. The brake is selected for 150% of load torque to ensure safe holding of load. It is made with 'BCH'/EMCO/UNITORC. Brakes are of 'Fail to Safe' type which means in case of failure of electric supply brake acts immediately. Brakes are mounted on the non-driving end of the motor and are easily accessible.



Motor

Foot mounted squirrel cage induction motors designed and manufactured to IS 325 of reputed make, are used. Motors are totally enclosed, half hour rated, with high starting torque, specially designed and built for Hoists duty. The Motors are suitable for frequent start stop as well as braking and are provided with class 'B' insulation.



Bottom Block

Bottom Block Assembly consist of dropforged steel 'C' type shank hook with ball thrust bearing mounted on heavy cross head trunnion, fixed on guarded sheave casting and load plates, designed to IS 3938 and are tested to 100% overload before use.

Trolley

Cross Traverse Trolley are designed to suit either standard Rolled Steel Joist or box girder. The Trolley frame is rigidly bolted with Hoist frame through series of holes. This also ensures proper adjustment of flange width. C.T. Wheels are provided with ball bearings & mounted on EN 8 Steel axles. The motorised trolley units have the spur gear box. Hand geared trolley & push pull trolley are also available.



Rope Drum

The Rope Drum is made of sturdy seamless pipe or fabricated from steel plates and is grooved to take the full lift without over winding. Large Drum diameter to Rope diameter ratio reduces wear and cable fatigue. The Drum shaft revolves in ball bearings, ensuring smooth running.

POWER TRAVEL WIRE ROPE HOIST

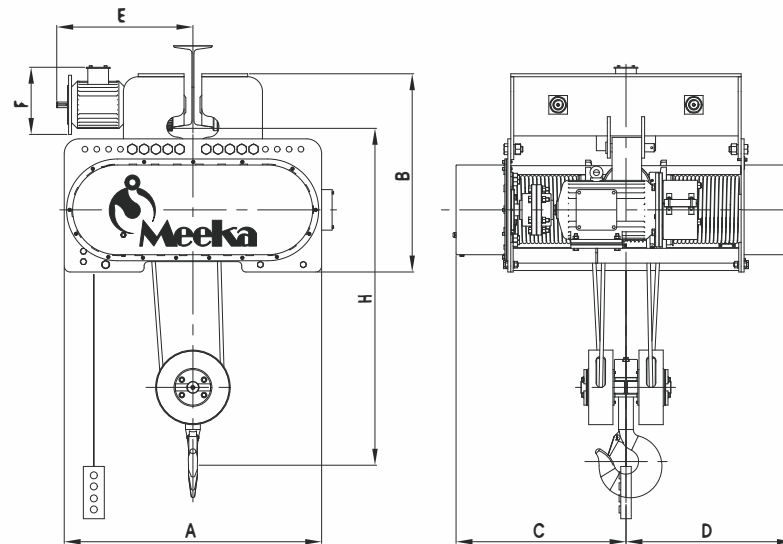

SPECIAL FEATURES

- ◆ Anti-fall system with "T" plate which protect hoist for falling.
- ◆ Anti-fall system with fail safe brake. Which automatically operate in case of any power failure.
- ◆ Compact, rugged & elegant in design and operations.
- ◆ Lightweight, robust construction.
- ◆ Upper and lower limit switches.
- ◆ Spherical roller bearing for reduce vibration and increase bearing life.
- ◆ low headroom.

APPLICATION

- ◆ Steel mills
- ◆ Foundries
- ◆ Chemical plants

MEEKA POWER TRAVEL WIRE ROPE HOIST are designed in accordance with I.S.-3938 and other relevant Indian Standards & Specification for Electric Wire Rope Hoist and factory regulation requirements. Electric Wire Rope Hoist are designed & developed in modular constructions superior quality which simplifies repairs & reduce downtime during preventive maintenance. The rope drum, gearbox, motor, brake and panel can be easily attended to. The frame is of sturdy design fabricated from steel plates and is welded/bolted type.

Standard capacities range from 0.5 TON to 16 TON. Higher capacities hoist can be manufactured as and when required by clients for special purposes.

This product can cover requirement of under mentioned type of hoist with few changes

FIX SUSPENSION HOIST | PUSH PULL HOIST

DUAL SPEED HOIST | HIGH SPEED HOIST

HIGH LIFT HOIST | HAND GEAR HOIST

Model No.	Capacity In kgs.	Falls of Rope / Driven	Height of Lift In mtrs.	Lifting Speed (M.P.M)	Travel Speed (M.P.M)	Hoist Motor (HP)	C.T. Motor (HP)	Flange Width of 'I' Beam	Head Room (H)	A	B	C	D	E	F
MH-1R	1000	2	6	4	18	1.5	0.25	90 – 140	700	600	450	435	325	430	140
MH-11	1500	2	6	3.5	16	1.5	0.5	90 – 210	800	680	575	500	425	570	160
MH-11	2000	2	6	3.5	16	2	0.5	90 – 210	800	680	575	500	425	570	160
MH-12	2000	2	6	5.6	16	3	0.5	100 – 210	1000	750	720	500	500	570	170
MH-12	3000	4 / 1	6	2.8	16	3	0.5	100 – 210	1000	750	720	580	420	570	170
MH-2R	3000	2	6	3.5	16	3	0.5	125 – 210	1050	920	670	610	540	580	170
MH-2R	5000	4 / 2	6	3.5	16	5	1	125 – 210	950	920	670	575	575	580	170
MH-3	7500	4 / 2	6	3.5	15	7.5	1	140 – 210	1150	1030	770	740	740	610	200
MH-4	7500	4 / 2	6	3	10	7.5	1	150 – 210	1250	1350	810	800	750	650	205
MH-4	10000	4 / 2	6	3	10	10	1	150 – 210	1250	1350	810	800	750	650	205
MH-15	15000	4 / 2	6	2.5	10	12.5	1.5	210	1650	1650	1150	930	870	900	300
MH-15	16000	4 / 2	6	2.5	10	12.5	1.5	210	1650	1650	1150	930	870	900	300



FLEXIBLE TROLLEY HOIST



MEEKA FLEXIBLE is the perfect solution along paths with turns and changes of direction. Wheels can be flat or angled to suit different type of profiles, to improve duration. These are effectively used to negotiate such movement. We provide Indian standard Flexible Trolley Hoists that is high on performance and low on maintenance.

TROLLY HOIST is the when moving loads turns and changes of bottom flanges and running behavior and increase premium quality hoists that are effectively used to negotiate such movement. We provide Indian standard Flexible Trolley Hoists that is high on performance and low on maintenance.

This Hoists are designed in accordance with I.S.-3938 and other relevant Indian Standards & Specification for Electric Wire Rope Hoist and factory regulation requirements.

Standard capacities range from 0.5 TON to 16 TON. Higher capacities hoist can be manufactured as and when required by clients for special purposes.

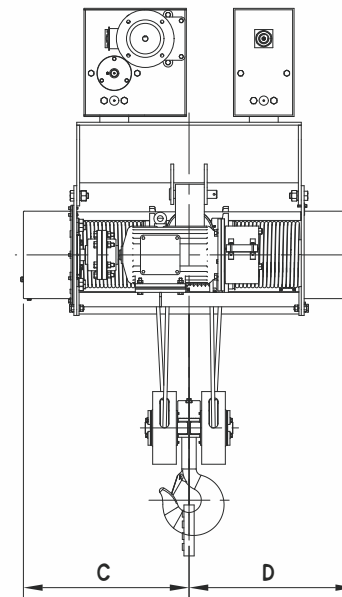
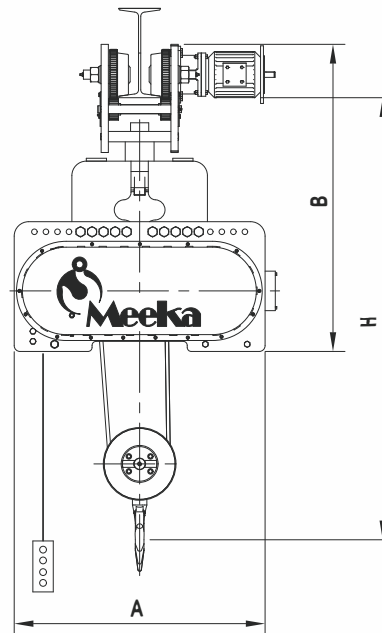

SPECIAL FEATURES

- ◆ Flexible trolley
- ◆ Pendant & remote control
- ◆ High speed
- ◆ Fail safe brakes
- ◆ Extensive cover of floor area

APPLICATION

- ◆ Foundries
- ◆ Bagging shop
- ◆ Chemical industries
- ◆ Special application shop
- ◆ Store rooms

Model No.	Capacity In kgs.	Falls of Rope / Driven	Height of Lift In mtrs.	Lifting Speed (M.P.M)	Travel Speed (M.P.M)	Hoist Motor (HP)	C.T. Motor (HP)	Flange Width of 'I' Beam	Head room (H)	A	B	C	D	E	F
MH-1R	1000	2	6	4	18	1.5	0.25	90 – 140	920	600	450	460	460	430	140
MH-11	1500	2	6	3.5	16	1.5	0.5	90 – 210	1100	680	575	515	515	570	160
MH-11	2000	2	6	3.5	16	2	0.5	90 – 210	1100	680	575	515	515	570	160
MH-12	2000	2	6	5.6	16	3	0.5	100 – 210	1220	750	720	460	460	570	170
MH-2R	3000	4 / 2	6	3.5	16	3	0.5	125 – 210	1300	920	670	575	575	580	170
MH-2R	5000	4 / 2	6	3.5	16	5	1	125 – 210	1170	920	670	600	600	580	170
MH-3	7500	4 / 2	6	3.5	15	7.5	1	140 – 210	1600	1030	770	740	740	610	200
MH-4	7500	4 / 2	6	3	10	7.5	1	150 – 210	1670	1350	810	800	750	650	205
MH-4	10000	4 / 2	6	3	10	10	1	150 – 210	1730	1350	810	800	750	650	205
MH-15	15000	4 / 2	6	2.5	10	12.5	1.5	210	2150	1650	1150	930	870	900	280
MH-15	16000	4 / 2	6	2.5	10	12.5	1.5	210	2150	1650	1150	930	870	900	280

BASE MOUNTED HOIST

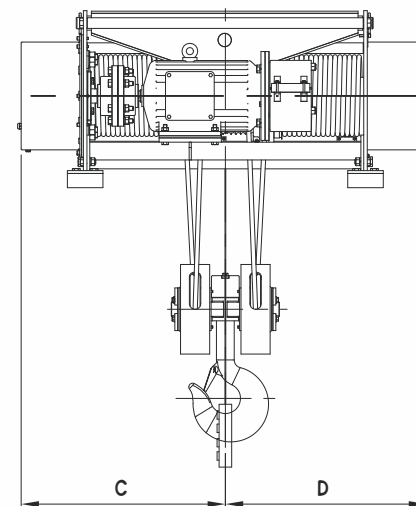
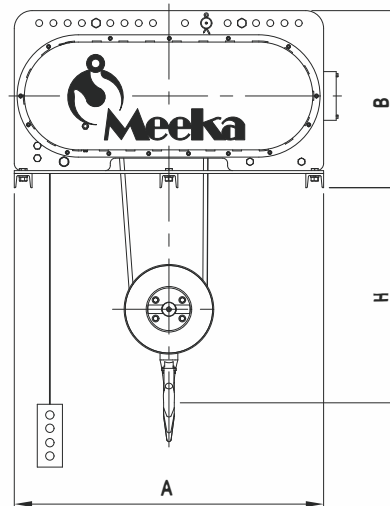

SPECIAL FEATURES

- ◆ Lightweight.
- ◆ Robust construction.
- ◆ Upper and lower limit switches.
- ◆ Spherical roller bearing for reduce vibration and to increase bearing life.

APPLICATION

- ◆ Unloaders
- ◆ Building construction
- ◆ Repair shop
- ◆ Tool rooms

MEEKA BASE MOUNTED HOIST generally used in goods lift where load need to move only up-wards and down-wards motion, This Hoists are designed in accordance with I.S.-3938 and other relevant Indian Standards & Specification for Electric Wire Rope Hoist and factory regulation requirements. Electric wire rope hoists are designed in modular constructions superior quality which simplifies repairs & reduce downtime during preventive maintenance. The rope drum, gearbox, motor, brake and panel can be easily attended to. The frame is of sturdy design fabricated from steel plates and is welded/bolted type.

Standard capacities range from 0.5 TON to 16 TON. Higher capacities hoist can be manufactured as and when required by clients for special purposes.

Model No.	Capacity In kgs.	Falls of Rope / Driven	Height of Lift In mtrs.	Lifting Speed (M.P.M)	Hoist Motor (HP)	CL of Base	Head Room (H)	A	B	C	D
MH-1R	1000	4 / 2	6	4	1.5	650	470	600	450	460	460
MH-11	1500	4 / 2	6	3.5	1.5	710	500	730	575	515	515
MH-11	2000	4 / 2	6	3.5	2	710	500	730	575	515	515
MH-12	2000	4 / 2	6	5.6	3	615	500	790	700	460	460
MH-2R	3000	4 / 2	6	3.5	3	790	550	1020	550	575	575
MH-2R	5000	4 / 2	6	3.5	5	840	600	1020	550	600	600
MH-3	7500	4 / 2	6	3.5	7.5	940	800	1030	750	740	740
MH-4	7500	4 / 2	6	3	7.5	955	800	1350	800	800	750
MH-4	10000	4 / 2	6	3	10	960	830	1350	800	800	750
MH-15	15000	4 / 2	6	2.5	12.5	1070	950	1650	1100	930	870
MH-15	16000	4 / 2	6	2.5	12.5	1070	950	1650	1100	930	870



DOUBLE RAIL TYPE HOIST

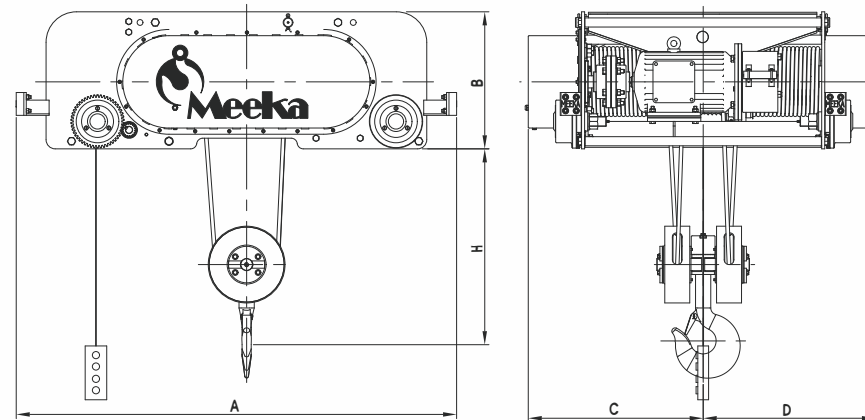

SPECIAL FEATURES

- ◆ Low headroom
- ◆ Cost effective
- ◆ Longer life
- ◆ Sturdy in design
- ◆ Cost effective

APPLICATION

- ◆ Ware house
- ◆ Machine shop
- ◆ Fabrication
- ◆ Small factory units
- ◆ Stock yard

MEEKA DOUBLE RAIL TYPE HOIST is unique product as replacement of crab for DOUBLE GIRDER CRANE for Superior clearance and headroom for double girder crane applications, this hoist covers all the standard feature of power travel hoist.

This Hoists are designed in accordance with I.S.-3938 and other relevant Indian Standards & Specification for Electric Wire Rope Hoist and factory regulation requirements. DOUBLE RAIL TYPE HOIST are designed in modular constructions superior quality which simplifies repairs & reduce downtime during preventive maintenance. The rope drum, gearbox, motor, brake and panel can be easily attended to. The frame is of sturdy design fabricated from steel plates and is welded/bolted type.

Standard capacities range from 0.5 TON to 16 TON. Higher capacities hoist can be manufactured as and when required by clients for special purposes.

Model No.	Capacity In kgs.	Falls of Rope / Driven	Height of Lift In mtrs.	Lifting Speed (M.P.M)	Travel Speed (M.P.M)	Hoist Motor (HP)	C.T. Motor (HP)	CL Rail	Head Room (H)	A	B	C	D
MH-1R	1000	4 / 2	6	4	18	1.5	0.25	765	470	920	400	460	460
MH-11	1500	4 / 2	6	3.5	16	1.5	0.5	835	500	1050	575	515	515
MH-11	2000	4 / 2	6	3.5	16	2	0.5	835	500	1050	575	515	515
MH-12	2000	4 / 2	6	5.6	16	3	0.5	755	500	1130	700	460	460
MH-2R	3000	4 / 2	6	3.5	16	3	0.5	815	550	1320	550	575	575
MH-2R	5000	4 / 2	6	3.5	16	5	1	965	600	1320	550	600	600
MH-3	7500	4 / 2	6	3.5	15	7.5	1	1100	800	1350	750	740	740
MH-4	7500	4 / 2	6	3	10	7.5	1	1100	800	1350	800	800	750
MH-4	10000	4 / 2	6	3	15	10	1.5	1160	830	1470	800	800	750
MH-15	15000	4 / 2	6	2.5	10	12.5	1.5	1250	950	1900	1100	930	870
MH-15	16000	4 / 2	6	2.5	10	12.5	1.5	1250	950	1900	1100	930	870

M.E CRAB TYPE HOIST

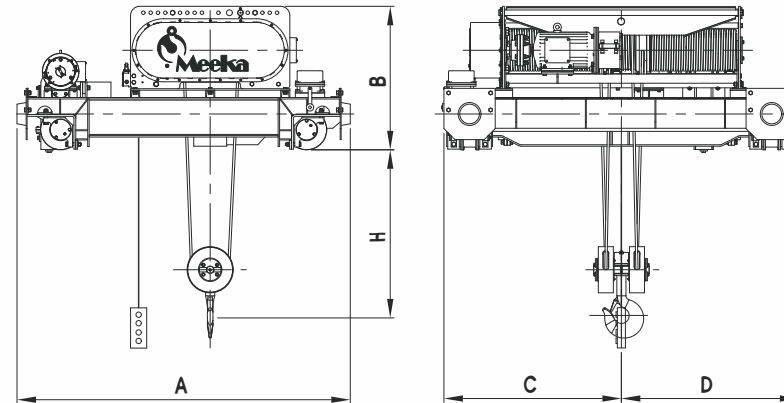

SPECIAL FEATURES

- ◆ Easy to maintain
- ◆ Sturdy design
- ◆ Cost effective
- ◆ Works with any double girder crane
- ◆ Save overall structural cost

APPLICATION

- ◆ Fabrication shop
- ◆ Maintenance shop
- ◆ Assembly shop
- ◆ General workshop
- ◆ Light duty engineering workshop

MEKA M.E CRAB TYPE HOIST is unique product as crab with hoist for DOUBLE GIRDER CRANE, this type of crab type hoist give more life to equipment, lesser vibration, easy for maintenance, this hoist covers all the standard feature of power travel hoist.

Standard capacities range from 0.5 TON to 16 TON. Higher capacities hoist can be manufactured as and when required by clients for special purposes.

This Hoists are designed in accordance with I.S.-3938 and other relevant Indian Standards & Specification for Electric Wire Rope Hoist and factory regulation requirements. M.E CRAB TYPE HOIST are designed in modular constructions superior quality which simplifies repairs & reduce downtime during preventive maintenance. The rope drum, gearbox, motor, brake and panel can be easily attended to. The frame is of sturdy design fabricated from steel plates and is welded/bolted type.

Model No.	Capacity In kgs.	Falls of Rope / Driven	Height of Lift In mtrs.	Lifting Speed (M.P.M)	Travel Speed (M.P.M)	Hoist Motor (HP)	C.T. Motor (HP)	Crab Gauge	Head Room (H)	A	B	C	D
MH-1R	1000	2	6	4	18	1.5	0.25	750	470	1450	700	500	500
MH-11	1500	2	6	3.5	16	1.5	0.5	850	500	1550	820	550	550
MH-11	2000	2	6	3.5	16	2	0.5	850	500	1550	820	550	550
MH-12	2000	2	6	5.6	16	3	0.5	900	500	1600	930	575	575
MH-12	3000	4 / 1	6	2.8	16	3	0.5	900	550	1600	930	575	575
MH-2R	3000	4 / 2	6	3.5	16	3	0.5	950	550	1750	850	600	600
MH-2R	5000	4 / 2	6	3.5	16	5	1	950	600	1750	850	600	600
MH-3	7500	4 / 2	6	3.5	15	7.5	1	1250	800	2000	1000	750	750
MH-4	7500	4 / 2	6	3	10	7.5	1	1350	800	2100	1070	800	800
MH-4	10000	4 / 2	6	3	10	10	1	1350	830	2100	1070	800	800
MH-15	15000	4 / 2	6	2.5	10	12.5	1.5	1600	950	2350	1450	950	950
MH-15	16000	4 / 2	6	2.5	10	12.5	1.5	1600	950	2350	1450	950	950



FLAME PROOF HOIST

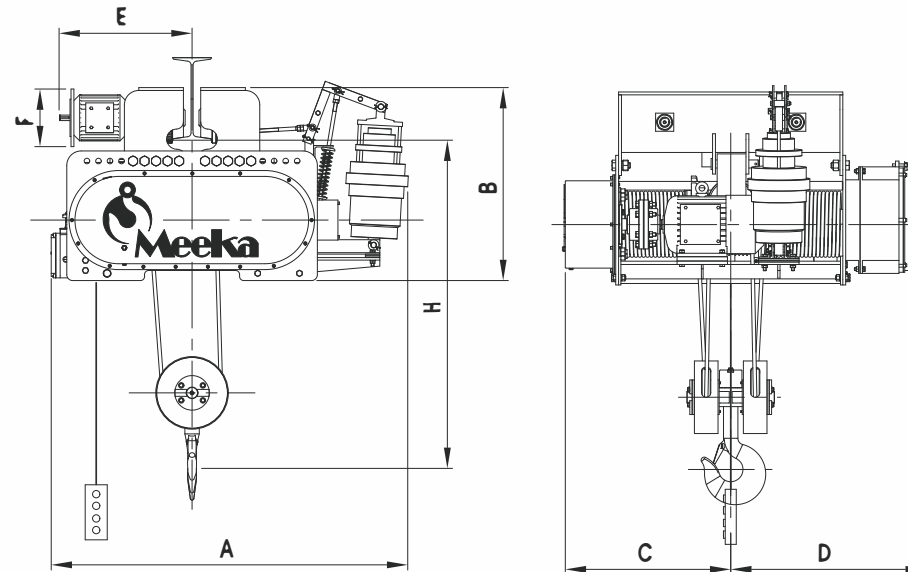

SPECIAL FEATURES

- ◆ CMRS & C.C.E Certificates
- ◆ ATEX Certificates
- ◆ Flame proof control panels
- ◆ Flame proof limit switches
- ◆ Flame proof push buttons

APPLICATION

- ◆ Refineries
- ◆ Chemical industries
- ◆ Gas handling industries
- ◆ Hazardous area industries

MEEKA FLAME PROOF HOIST are designed in accordance with I.S - 3938 and I.S 2148 suitable for Gas Group –II A, IIB & II-C., which are fitted with Hazardous enclosures approved by CMRS & C.C.E.

We have developed specialization in manufacturing of Hazardous hoists suitable for Gas Group –II A , IIB & II-C , MEEKA flame proof hoist are widely used in major petrochemicals, chemicals, Fertilizers project across India & other countries . Companies like Indian Oil Corporation, Engineers India LTD, GNFC, GSFC, Technip India, Toyo engineering India ltd, & many more companies, we are approved vendor for almost every refineries in India.

Standard capacities range from 0.5 TON to 16 TON. Higher capacities hoist can be manufactured as and when required by clients for special purposes.

Model No.	Capacity In kgs.	Falls of Rope / Driven	Height of Lift In mtrs.	Lifting Speed (M.P.M)	Travel Speed (M.P.M)	Hoist Motor (HP)	C.T. Motor (HP)	Flange Width of 'I' Beam	Head Room (H)	A	B	C	D	E	F
MH-11	1000	2	6	3.5	16	1	0.25	90 – 210	950	910	725	500	625	650	160
MH-11	1500	2	6	3.5	16	1.5	0.5	90 – 210	950	910	575	500	625	650	160
MH-11	2000	2	6	3.5	16	2	0.5	90 – 210	950	910	575	500	625	650	160
MH-12	2000	2	6	5.6	16	3	0.5	100 – 210	1150	1000	820	500	700	650	170
MH-12	3000	4 / 1	6	2.8	16	3	0.5	100 – 210	1150	1000	820	580	620	650	170
MH-2R	3000	2	6	3.5	16	3	0.5	125 – 210	1200	1200	850	610	725	660	170
MH-2R	5000	4 / 2	6	3.5	16	5	1	125 – 210	1100	1200	850	575	760	660	170
MH-3	7500	4 / 2	6	3.5	15	7.5	1	140 – 210	1350	1300	950	740	830	670	200
MH-4	7500	4 / 2	6	3	10	7.5	1	150 – 210	1350	1350	900	800	850	750	205
MH-4	10000	4 / 2	6	3	10	10	1	150 – 210	1350	1350	900	800	850	750	205
MH-15	15000	4 / 2	6	2.5	10	12.5	1.5	210	1650	1650	1150	930	960	900	300
MH-15	16000	4 / 2	6	2.5	10	12.5	1.5	210	1650	1650	1150	930	960	900	300

PRESTIGIOUS CLIENT LIST



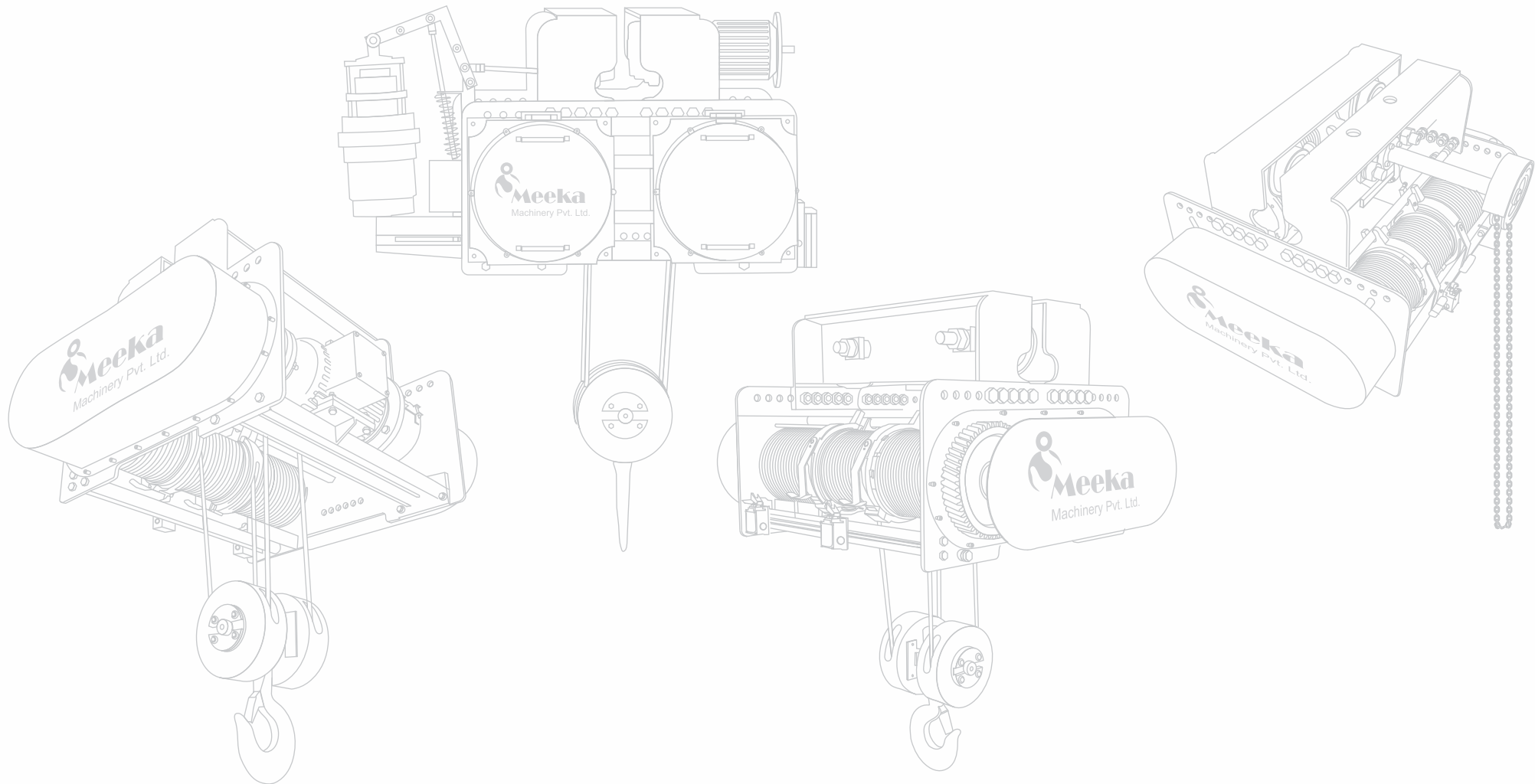

Think Performance
Think of Us



MEEKA MACHINERY PVT LTD

Reg Office and Plant - 1

3822/B ,G.I.D.C, Phase-IV, VATVA,
Ahmedabad - 382 445. Gujarat, INDIA

Plant - 2

495, Tajpur, Sarkhej-Bavla Highway, Changodar,
Ahmedabad - 382 210. Gujarat, INDIA

Sales and Service Head Commercial

Mr. Chitvan Mehta

Mo: +91-9879459660

land line No.: 079 25840951

Sales e-mail: sales@meekamachinery.com,

info@meekamachinery.com

 www.meekamachinery.com

 www.facebook.com/meekamachinery

 www.linkedin.com/company/meeka-machinery-pvt-ltd

 www.twitter.com/meekamachinery