

Series ZYD-W Fully Enclosed Outdoor Use Type High Vacuum Transformer Oil Purifier

It filters & purifies :

- Transformer Oil
- Insulating Oil
- Cable Oil
- Dielectric Oil
- Mutual Inductor Oil
- Switchgear oil

- Fully enclosed
- Weather-proof for outdoor use
- Movable with caster wheels mounted
- After remove the caster wheels, skid base mounted is available
- Hooks equipped for lifting



- multi-stage filtration
- Step-to-step heating
- vacuum dehydration
- drying
- degassing
- Particles removal
- oil filling & Transferring
- vacuum pumping/Transformer evacuating
- Dielectric strength Improving
- Recovers the oil's properties

ATTN: Mr. Kevin Dube Tel/Fax: 0086 23 8823 9845
Mob/WhatsApp: 0086 135 2739 0908
Email: sales@fuotech.com, kevinnciang@gmail.com
Add: No.5 Hongshi Street, Jiulongpo District, Chongqing, China



PHOTOS OF PRODUCTS





WHO WE ARE

- ◆ **Fuootech Oil Filtration Group** is one of largest R&D based high-tech group engaged in designing, developing, manufacturing and exporting various vacuum oil/fluid purifiers, oil filtration system, oil regeneration machine , transformer evacuation system, dry air generator, electrical testing equipment and oil testing kits for various industries for more than 18 years, helping clients all over the world solve various oil problems.
- ◆ **Fuootech** develops custom solutions for virtually any application involving industrial oil management. With **Fuootech** oil management systems, oils can be re-used indefinitely, thus drastically reducing new oil purchasing and waste oil disposal, protecting environment, and improving productivity for industries to be more competitive in the global economy.
- ◆ Nowadays, the company's sales and service network covers all the provinces of China and exports to more than 118 countries. Our products are more and more popular in domestic market and international market based on High quality, advanced technology, competitive price and excellent before & after sales service, as well as continuous technical supports.
- ◆ **Fuootech's** oil filtration systems & oil testing kits are extensively used in the fields of electrical power, power station, power transmission, power generation, Petrochemical, petroleum, Paper and Pulp, compressor, mechanical manufacture, steel mills, electrical utilities, engineering contractors, metallurgy, railway, aviation etc. which are consuming various oils. More than 100 standard models are offered to different clients and also can be customised according to actual need of oil solutions in different areas.





PRODUCT INTRODUCTION & FEATURES

Introduction

- ◆ As is well known the Transformer plays an important role in the generation, transmission and distribution of electrical energy. Under load the transformer, dissipates heat and the insulating oil acts as a coolant as well as an effective dielectric.
- ◆ Due to the highly hygroscopic nature of the transformer oil, it absorbs moisture from windings, which leads to gradual deterioration of dielectric strength. Also there are some waste impurities, gas contents in the transformer oil which destroy the oil's quality.
- ◆ FuooTech Series ZYD-W fully enclosed type double stages vacuum transformer oil purifier combines one high quality rotary vane vacuum pump and one booster roots pump which can speed up evacuation much faster. Series ZYD-W which equipped with a special oil regeneration device has been specially designed for on site use to completely purify the insulating oils in energized or de-energized transformers even when transformer power both below and above 110KV and altitude over 500 meters, as well as purify mutual inductor oil, switch oil and so on. Also it can inject the insulating oil into the transformers on-line and dry the transformer.
- ◆ Series ZYD-W oil filtration machine not only provides regular oil purification/ reclamation such as degassing, drying and particulate removal, removes liquid water, trace water, gasses, dust and sludge, but also can remove acidity, sludge, carbon deposits, sulfur, and other soluble oil decay products and improve physical & chemical properties comparable to new transformer oil.
- ◆ This is accomplished by the use of high vacuum degasification technology and particulate filters combined with our special brand of earth. After treating, the oil can be reused as new.
- ◆ This machine is made in fully enclosed type, all components such as pumps, motors, filters, tanks, valves, pipelines, controls, etc... are totally enclosed and protected by cover and heavy duty doors enclosure and designed for lifting crane (equipped with lifting hooks). The equipment inside will be facilitated by a system of door locks installed at a perimeter of the enclosure.

Features

- ◆ Duplex 3D stereo-evaporation, efficient oil film sprayer, eliminating the liquid water quickly, increasing separating size and separating time to ensure the dry-level and dielectric strength improving greatly.
- ◆ Double-stage vacuum system, high vacuum pressure and high flow rate, strong power of vacuum evacuating,
- ◆ Advanced Multi-stage precision filtration system, stainless steel materials filtration combined with molecular adsorption filtering technologies
- ◆ Besides the common vacuum oil purifier's function of dewatering, degassing and eliminating particles, this machine can regenerate the seriously deteriorated oil by removing the polarity materials, such as the deep oxides, free carbon in the oil effectively. It can make the seriously deteriorated oil reach to the normal index like anti-oxides, acid-alkali water-solubility.
- ◆ UK G technology by which the trace water that is show chain, such as dissolved water, can be removed effectively.
- ◆ Efficient electric carbon fiber infrared heating system, heating uniformity, less power consumption, safe, and reliable.
- ◆ Double-infrared liquid level sensor, pressure protective system to ensure machine operation easy and safely.
- ◆ Especially applied to vacuum oiling and drying (Hot Oil Circulation / on-site Drying) for power transmission equipments which are over 110KV.
- ◆ Adopt interlocked protective system, which connect oil pump, heater and liquid level sensor, avoiding blank heating, blank pumping, oil leak and electricity leak. If there is any fault, machine will be power off automatically.
- ◆ Advanced dielectric Condenser devices and flow meter measuring flow rate.
- ◆ Low maintenance cost and time, simple operation and maintenances.
- ◆ Fully enclosure for weather proof outdoors usage
- ◆ Designed to easy access for handling, checking, operating, and maintenance and can be moved easily with forklift and crane with 4 high quality hooks.

TECHNICAL SPECIFICATION

Parameters	Model Unit	ZYD-W-30	ZYD-W -70	ZYD-W -100	ZYD-W -150	ZYD-W -200	ZYD-W -250	ZYD-W -300
Flow Rate	L/H	1800	4000	6000	9000	12000	15000	18000
Working Vacuum Degree	MPa	-0.08 ~ -0.099						
Working Discharge Pressure	MPa	≤ 0.3						
Temperature Control	°C	20 ~ 80						
Operation Temperature	°C	40 ~ 70 (65°C is best)						
Power Supply		415V, 50Hz, 3 phases (or as per your requirements)						
Working hours without Trouble	Hour	4000						
Continuous Working Hours	Hour	150						
Ambient Temperature		-25 ~ 55°C						
Working Noise	dB (A)	65 ~ 90						
Heating Power (adjusted available)	KW	30	36	48	60	72	80	120
Total Power	KW	35.5	42	52.5	68	82	93	135
Inlet/Outlet	mm	φ25	φ32	φ42	φ50	φ50	φ60	φ60
Gross Weight	KGS	600	1060	1190	1350	1490	1600	1950
Dimension L×W×H	mm	1450 ×1050 ×1860	1710 ×1350 ×2150	1900 ×1420 ×2190	1940 ×1480 ×2220	2120 ×1500 ×2240	2150 ×1700 ×2350	2300 ×1850 ×2460

The dimension and weight will be changed with changing of technical specs. FUOOTECH reserves the rights to any upgrading without notification.

www.fuotech.com



OIL RESULT AND WORKING PRINCIPLE

Oil Result Before and After Treatment

Parameter	Non-treated Oil	After Treatment
Moisture (Water Content)	≥ 120 ppm	≤ 3 PPM
Gas/Air Content	10%	$\leq 0.01\%$ (Vol)
Impurities Degree (Filtration precision)	2%	≤ 1 micron (no free carbon)
Breakdown Voltage (Dielectric Strength)	25 kV	≥ 72 KV
Flash Point	70	$\geq 145^{\circ}\text{C}$
Cleanliness	NAS 1638 Grade 10	\leq NAS 1638 Grade 6

Working Principle

When this machine start working and vacuum degree is upto the set value, the used oil will be sucked into the primary filter & secondary filter under the pressure difference, the primary filter & secondary filter will remove the big size impurities/ particles, then the oil which just contains the tiny particles is heated by the heaters. Then the heated oil enter into the vacuum separator, through the function of vacuum pressure and degassing system, the moisture content in the oil, which is vapoured & Separated from the oil quickly, is either discharged under the process of the vacuum system or refrigerated to liquid water into water receiver, meanwhile degasification work is completed, and then fine filter removes the tiny impurities completely. Finally, clean oil goes out through the oil outlet.



FLOW CHART OF SERIES ZYD-W

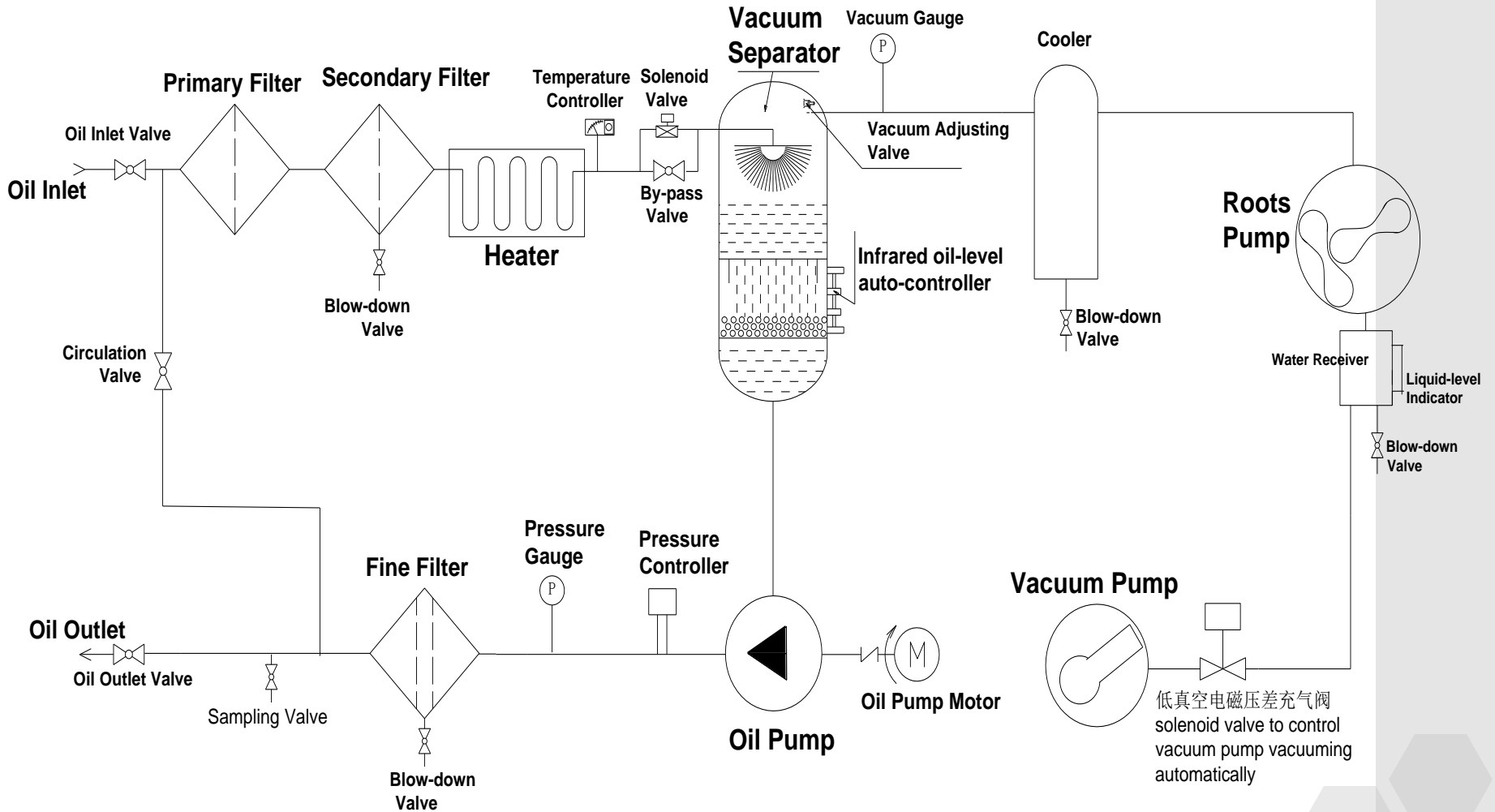

STRUCTURE DIAGRAM OF SERIES ZYD-W

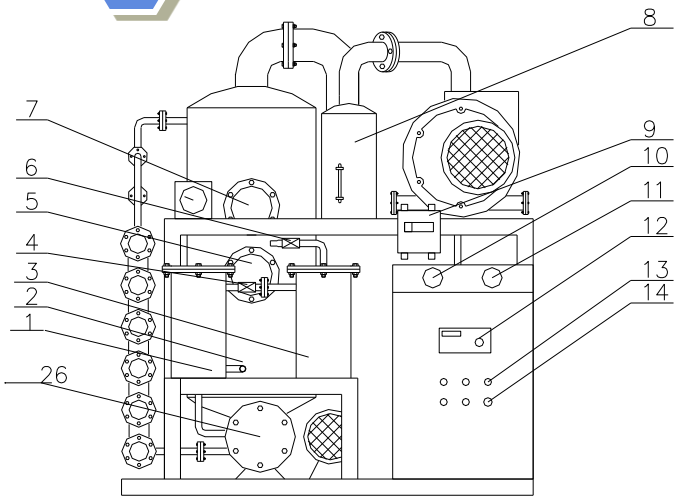

Main front side

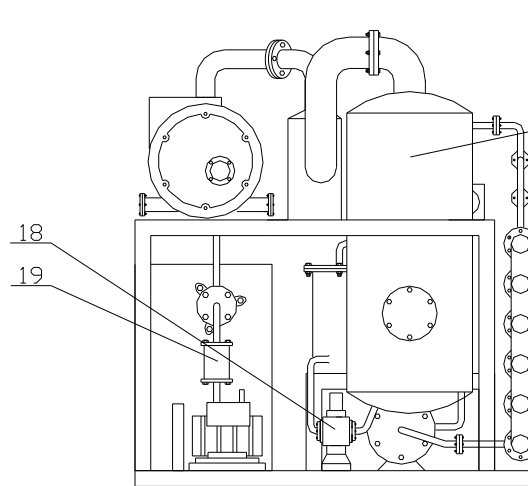

Back side

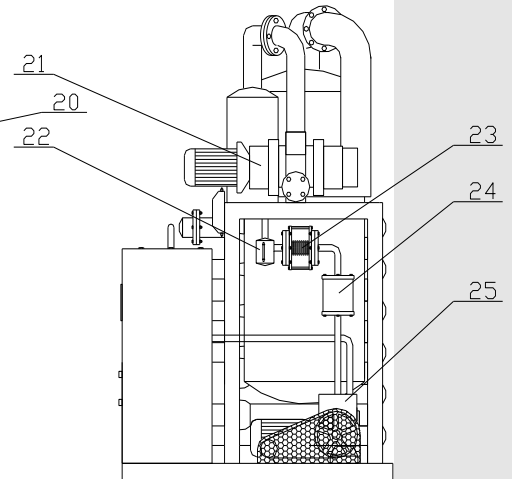

Right side

1. Primary Filter
2. Oil Inlet
3. Fine Filter
4. Return Valve
6. Oil Outlet
- 5 & 7. Observe Hole
8. Cooler
9. Pressure Controller
10. Vacuum Gauge
11. Pressure Gauge
12. Temperature Controller
- 13.14. Control Button
15. Solenoid valve
16. By-pass Valve
17. Heater
18. Oil pump
19. Single Way Valve
20. Vacuum Separator Chamber
21. Roots Pump
22. Water receiver
23. Ripple Compensator
24. Single Way Valve
25. Vacuum Pump
26. Secondary Filter

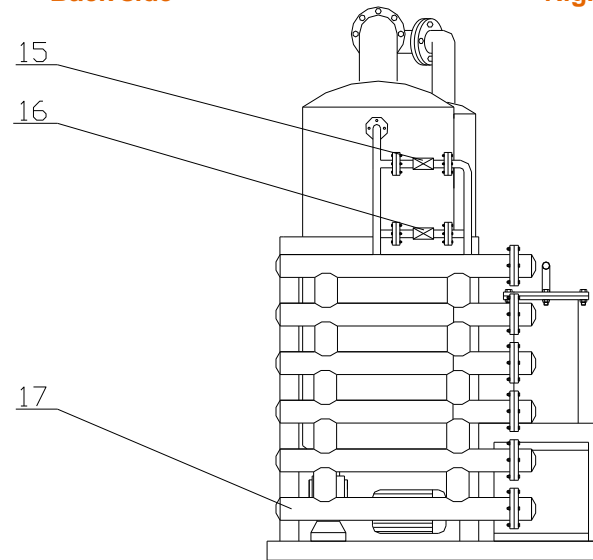

Left side



MAIN ADVANCED TECHNOLOGIES

Unique High Efficiency Dehydration & Degassing System

- ◆ We adopt heavy-duty-designed Duplex 3D stereo-evaporation technology whose the evaporation area is three times more than that of normal evaporation technology. This innovation can dehydrate and degas effectively and efficiently.
- ◆ Meanwhile, we bring in UK G technology from Japan which eliminates the kinds of trace water content and dissolved water thoroughly so as to increase the breakdown voltage and anti-pressure value enormously, ensure the transformer oil can be used in high level transformer normally.
- ◆ Sight Glass installed for observation of oil evaporation and oil flow level indicator for degassing chamber is installed.
- ◆ Effective vacuum adjusting valve is designed specially for adjusting suitable vacuum degree inside of vacuum chamber according to actual operation condition.
- ◆ Blow-down valve and safety valve equipped for necessary operation while use.

Distinctive Multi-stage Filtering System

- ◆ The filtering system, whose filters are constructed by double FH trapezoidal network high technology, distinctively remove more than 99.9% of various impurities and particles. It improves the effectiveness of filtering and extends the lifetime of filter awfully.

A: First-stage Filter

- ◆ Made of Stainless steel material, Double FH trapezoidal network filtering technology, it removes any large particles and impurities down to 20 microns, protecting the inlet pump away from any damage from these big size particles.

B: Second-stage Filter

- ◆ Made of Stainless steel material, Double FH trapezoidal network filtering technology, it removes particles and impurities down to 5 microns.

C: Fine Filter

- ◆ Made by High Polymer Materials and imported from Germany, thorough demulsification and separate water from the waste oil, it removes particles and impurities down to 1 microns, making oil clean.
- ◆ All filters can be easily and fast changed if any damaged due to wrong operation or too dirty oils. Blow-down valves are equipped and pressure gauges installed to monitor the differential pressure values.
- ◆ Also other filters can be designed to install on the machine according to customer's actual requirements.



MAIN ADVANCED TECHNOLOGIES

High performance of Double-stage Vacuum pump system

- ◆ Double stage vacuum pump system keeps oil filtration machine operation with high performance at the higher vacuum status than single stage vacuum.
- ◆ The integral vacuum pump system consist of a rotary vane vacuum pump and a booster roots pump, keep the machine's filtration jobs at high vacuum degree, meanwhile pumping air out from the transformers (transformer evacuation) is also available. All these vacuum pumps' works can be customized according to the actual operation condition and client's requirements.
- ◆ Rotary vane vacuum pump can be chosen as Germany Leybold Vacuum Pump Brand with much higher quality and low noise as option.

Electrical Control System & Control Panel (Cabinet)

- ◆ Electrical control system is one of the most important parts for oil filtration machine, which control and protect the whole filtration process, keeping danger away from operators.
- ◆ All the electrical parts are chosen and compared by our professional electrical engineers from hundreds of brands products. And the wiring & installation of electrical parts are well designed according to operators' operation habit.
- ◆ All Electrical Control Gear, Mains Isolating Arrangement, Starters, Contactors, Fuses, Relays, Indicating Lamps and Interlocking, etc. are well housed in a Compact Control Cabinet, as well as the lights, Volt meter, Amp meter, pushing buttons, vacuum gauge, pressure gauge, temperature controller screen, indicators, etc.. are also well installed on the control panel.
- ◆ German 3UG3 Relay keep the machine safe working efficaciously at any situations such as power off, lack of phase, wrong phase position, etc...

Carbon Fiber Infrared Oil Heating System

- ◆ Heating by Carbon fiber infrared heating system which is the most advanced heating technology, the unique heater structure heats the oil uniformly and easily controlled, it gives out the heat quickly (in 3 seconds after power on) and Efficiency of electricity transforming to heat is very high (more than 98%).
- ◆ Oil Heater System assures less than 1.0 w/cm². During the heating process, the deterioration of the oil caused by overheating is avoided. The oil temperature can be adjusted between 0 ~ 120°C. The heater is controlled manually or automatically. The heater will stop automatically when the oil temperature reaches a certain degree. Being installed with safety protection devices, the heating system is secure and reliable. The heater will stop operation automatically when the oil volume of inlet is too low to avoid the damages of the heater.
- ◆ The material is good at oxidation resistance at high temperature and can be used for more than 10 years.



MAIN ADVANCED TECHNOLOGIES

Double-infrared fluid level auto-control system instead of oil-level controlled by manually and float valve

- ◆ Double-infrared fluid level auto-control system is installed in the vacuum vessel to control the oil level automatically so as to avoid the oil leaking in the operation. It can help machine working continuously for 150 hours even online without worker monitor. The new innovation of eliminating froth can avoid the oil ejecting and gushing during the process.

High Quality components

- ◆ The main component parts of our products such as vacuum pump, oil pump and electric apparatus are from SIEMENS, ABB, SCHNEIDER, FUOTECH and AMICO etc. Kinds of brands are optional according to customer's specific requirement. It ensures our products high quality and reliability.
- ◆ Some extra components are available to install on our oil filtration machine as per client's requirements, such as flow meter, PLC, hooks, doors, covers, alarms, special Logo, etc...

Structure and Appearance of Oil purifier

- ◆ Our products adopt ship-shape chassis-mount structure to ensure oil leak proof and protect the environment from pollution. The whole equipment is characterized by small size, light weight and convenient to move around.
- ◆ Available in mobile option, immovable option and trailer, etc...
- ◆ Oil purifier can be made in hermetical, canopy-covering, open and frame style, etc...
- ◆ Color of the oil purifier can follow customer's favor.
- ◆ Available in installing PLC controller for making machine operation Fully-automatically
- ◆ Equipped with Explosion Proof Materials when the machine is used in hazardous areas is optional

Cooler, Dielectric Condensation System

- ◆ The system is composed of cooler, condenser, water receiver etc
- ◆ The vapor and other gas, which is evaporated from vacuum separator, first drop in temperature and are rid of moisture in dielectric condenser whose decalescence medium changes water vapour changes to liquid water quickly, then are condensed again in cooler.
- ◆ The reductive condensed water is discharged by water receiver. The dry gas, which are condensed and rid of moisture twice, are discharged to air by vacuum pump so that it protects vacuum pump.



MAIN ADVANCED TECHNOLOGIES

Oil discharge pumps

- ◆ High quality and durable oil discharge pump well keeps balance between the oil inside of machine and outside of oil discharged from and to storage tanks or drums.
- ◆ Special valves installed and high quality motors equipped.

Gauges, meters, alarms are keeping the whole operation safe

- ◆ Vacuum gauge, pressure gauge, temperature display, flow meter, etc... are installed to monitor the whole operation of the oil purifier and various alarms give various warnings to operator while any problem happens so as to remind him to stop the machine for check.
- ◆ The whole operation is under control and 100% safe, reliable, and protected.

Testing and Inspection

- ◆ All the oil purifier machines will be well tested and completely inspected in factory by technicians prior to shipment and certificates will be issued as well. Followings are at least carried out:
 - A. General construction inspection test
 - B. Operation test
 - C. Vacuum, air and oil Leakage tests

Instruction manual documentation

- ◆ The equipment will be delivered with detail operation manuals and all the safety operations and alarms. Also will have complete series of drawing and diagrams (also electrical and flow diagrams). Both CD copy and printed copy of manuals are available.
- ◆ All document are normally supplied in English language, if other language required, please inform us specially.



MAIN ADVANCED TECHNOLOGIES

Fully Enclosed for outdoors usage, Weather proof

- ◆ This oil purifier machine is made in fully enclosed type, all components such as pumps, motors, filters, tanks, valves, pipelines, controls, etc... are totally enclosed and protected by cover and heavy duty doors enclosure and designed for lifting crane (equipped with lifting hooks). The equipment inside will be facilitated by a system of door locks installed at a perimeter of the enclosure.

Warranty Period & Guarantees

- ◆ FUOOTECH Warrants the plant supplied under this specification against defects in material and workmanship under normal use and service for a period of twenty-four (24) Months after the Goods have been set up or for twenty-six (26) months after date of shipment, and providing of consumable parts of the equipment within 24 months (warranty period).
- ◆ FUOOTECH's obligation under this warranty is limited to repairing or furnishing, without charge F.O.B. point of manufacture, a similar part to replace any part (except filter), which was proven to defective within warranty period.
- ◆ FUOOTECH will not in any event be held responsible for any indirect or consequential damages.

Recommended consumables and spare parts

- ◆ FUOOTECH normally list the some recommended consumables and spare parts of the offered equipment for customers on the Operations and Maintenance, customers can select the parts that they deem necessary, such as filters, valves, couplings, seals, hoses, Cables, electrical parts, among others, to be supplied
- ◆ According to 18 years' experience in this business line, FuooTech normally provides the necessary consumables and spare parts for 2 years of operation.



THE INDUSTRIES WE ARE INVOLVING AND SERVICING

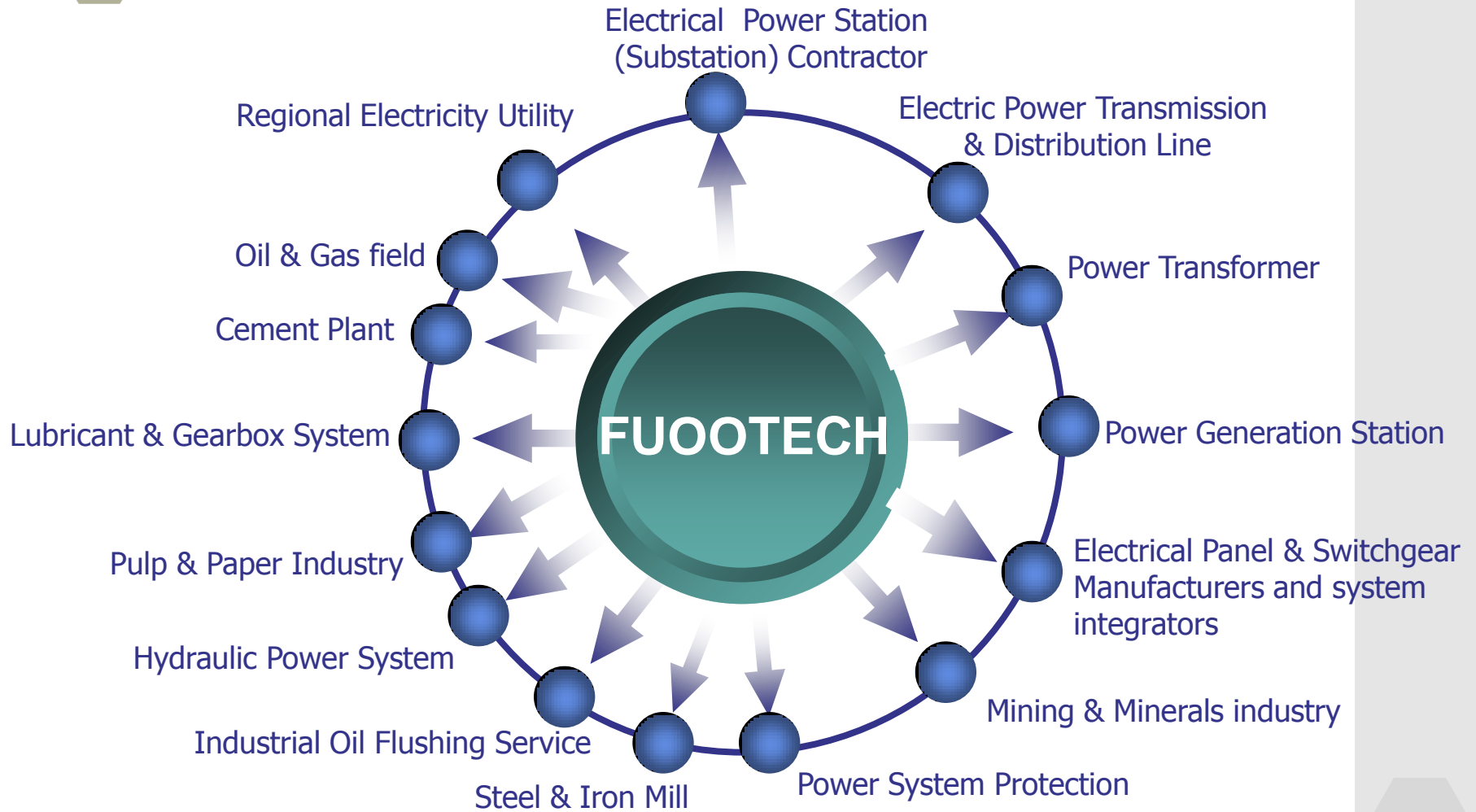

More other industries are also not listed here, but also involved



OUR MAIN PARTNERS & CLIENTS

ALSTOM

SIEMENS

ABB

oerlikon
leybold vacuum

هيئة كهرباء ومياه دبي
Dubai Electricity & Water Authority



KARACHI ELECTRIC
SUPPLY COMPANY

SFG



Bangladesh Power Development Board



More other partners and clients are also not listed here

www.fuotech.com

FUOTECH'S PRODUCTS ARE FILTERING, PURIFYING, REGENERATING

- ◆ **Insulating Oil**
- ◆ **Lubricating Oil**
- ◆ **Cable Oil**
- ◆ **Industrial Oil**
- ◆ **Transformer Oil**
- ◆ **Turbine Oil**
- ◆ **Vacuum Oil**
- ◆ **Transmission Oil**
- ◆ **Dielectric Oil**
- ◆ **Mutual Inductor Oil**
- ◆ **Switchgear Oil**
- ◆ **Circulating Oil**
- ◆ **Compressor Oil**
- ◆ **Cutting Oil**
- ◆ **Gear Oil**
- ◆ **Heat Transfer Oil**
- ◆ **Hydraulic Oil**
- ◆ **Cooking Oil (UCO)**
- ◆ **Fire Resistant Hydraulic Oil**
- ◆ **Engine Oil**
- ◆ **Coolant Oil**
- ◆ **Quench Oil**
- ◆ **Soluble Coolants**
- ◆ **Rolling Oil**
- ◆ **and more ...**



BENEFITS FROM FUOTECH'S PRODUCTS

- ◆ Removes Dissolved Moisture from Transformer Oil
- ◆ Reduces combustibile gases and oxygen
- ◆ Improves oil dielectric values
- ◆ Improves transformer power factor
- ◆ Extends oil service life
- ◆ Extends transformer service life and reliability
- ◆ Protect transformer, power station, power plants
- ◆ Zero disposal of waste oil
- ◆ Eliminate new oil purchases and reduce oil inventories
- ◆ Keep equipment working more efficiently
- ◆ Protect machinery and reduce maintenance time
- ◆ Create a cleaner environment
- ◆ Extended lubricant life
- ◆ Minimized "stick-and-slip" of bearings and gears
- ◆ Less wear on servos and O-rings
- ◆ Reduced machine downtime
- ◆ Less equipment maintenance
- ◆ Significantly reduced overall costs
- ◆ Cost savings from fewer oil changes, less associated labor
- ◆ Eliminate oil changes by always keeping oil like new
- ◆ Fuel consumption savings through increased engine efficiency
- ◆ Extend engine life with resultant increased times between major overhauls and reduced capital expenditure to replace damaged equipment
- ◆ Win profits from our oil purifier machines when you resell or rent to others





FUOTECH'S OVERSEA PROJECTS & TRAINING



South Africa



Pakistan



Saudi Arabia



Tanzania



Bangladesh



Malaysia



Cambodia



Dubai, UAE



Zambia



Nigeria



Laos



Zimbabwe (ZPC)

More projects are not listed here

TECHNICAL SUPPORTS & AFTER-SALE SERVICES

FuooTech Oil Filtration Group has a professional after-sales service team, We are in the spirit of "high quality, excellent service, create first-class brand" and base on the principle of "quality equipments, reasonable price and warm-heat service". we can provide our customers free installation and adjustment of machine, free training and two years warranty from final acceptance.

During warranty period, if the purchaser discovers defects in workmanship and or material and so notifies the supplier promptly in writing, we have the responsibility to dispatch the technician and provide supplementary accessories within twenty days from the date of receipt of written notification from the purchaser.

We will provide 24-hour one-stop service to ensure that we can deal with customer issues in first time

Service target: Always to provide customers with satisfactory service.

We also provide OEM & ODM Service & Solutions to your specific needs according to the actual market plan. Please Contact Us for more details.

7*24 Technical Supports and After-sale services are also available for all clients.

We also provide the professional installation, commissioning, training services for customers at their working site.

Technical Upgrade and improvement are also belongs to our experienced services.

For more services, please don't hesitate to contact us. We will provide you the best solutions.



CONTACT US



Thank You!
LOOK FORWARD TO
COOPERATING WITH YOU!

ATTN: Mr. Kevin Dube, Tel/Fax: 0086 23 8823 9845
Mob/WhatsApp: 0086 135 2739 0908
Email: sales@fuotech.com, kevinchiang@gmail.com
Add: No.5 Hongshi Street, Jiulongpo District, Chongqing, China

