



Building Automation

Solutions for
Renewable Energy

Renewable Energy

Solutions for

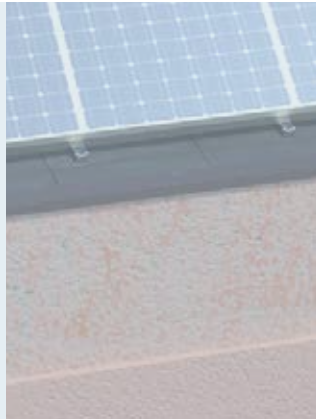

Photovoltaic parks

Photovoltaic small business, commercial and tracking systems

Photovoltaic residential systems

Off-grid systems

ABOUT CARLO GAVAZZI

Carlo Gavazzi Automation is an international group active in designing, manufacturing and marketing electronic equipment targeted at the global markets of industrial and building automation.

Our history is full of firsts and our products are installed in a huge number of applications all over the world. With more than 80 years of successful operation, our experience is unparalleled.

We have our headquarters in Europe and numerous offices around the world.

Our R&D competence centres and production sites are located in Denmark, Italy, Lithuania, Malta and the People's Republic of China.

We operate worldwide through 22 of our own sales companies and also selected representatives in more than 65 countries, from the United States in the West to the Pacific Rim in the East.

Our core competence in automation spans four product lines: Sensors, Switches, Controls and Fieldbuses.

Our wide array of products includes sensors, monitoring relays, timers, energy management system, solid state relays, safety devices and fieldbus systems.

We focus our expertise on offering state-of-the-art product solutions in selected market segments.

Our customers include original equipment manufacturers of packaging machines, plastic injection moulding machines, food and beverage production machines, conveying and material handling equipment, door and entrance control systems, lifts and escalators, as well as heating, ventilation and airconditioning devices.



DESIGNED TO MEET MARKET REQUIREMENTS

The increasing demand for energy, the availability and cost of oil and issues of pollution make alternative sources of renewable energy essential.

Sun and wind energy can be transformed into electricity that can be used directly or fed into the grid according to national regulations.

Renewable energy, in combination with energy efficiency, is the basis for sustainable development and respect for the environment in which we all live.

Carlo Gavazzi's wide expertise is focused on developing and offering

a package of products and devices for the Renewable Energy market, specifically photovoltaic power plants.

The growing development of cost effective solar energy technology has great potential to benefit our world.

Solar technologies diversify the energy supply, reduce our dependence on fossil fuels, improve air quality and offset greenhouse gas emissions.

Carlo Gavazzi offers complete and modular solutions to monitor and control the efficiency of photovoltaic plants.

Our PV monitoring solution consists of Eos-Array, Eos-Web devices and Eos-Server and VMU-Y aggregating

solutions, depending upon the requirements and complexity of the photovoltaic plant.

The Eos-Array and Eos-Array Lite are modular systems, providing efficient local string control to the PV plant.

The Eos-Web is a web-server suitable for controlling and supervising small to medium installations as a stand-alone solution, also large plants and portfolios when used together with the Eos-Server and VMU-Y devices.

Renewable Energy

Photovoltaic parks



Embedded aggregation server

Cloud multi-site aggregation server

Solar control solution

Surge arresters

Current transformers

VMU-Y PV

Eos-Server

Eos-Array

**DSF
DSB
DSC**

**CTD
TADK**

In terms of scale and accessibility, solar parks represent the most economical option as regards planning and construction. Carlo Gavazzi products ensure an important contribution to the maximum capacity utilization of the solar electricity produced in photovoltaic power plants - both fixed

plants or plants with tracking systems, with 1 or 2 axes.

To complement photovoltaic modules, Carlo Gavazzi provides many components for a photovoltaic installation, especially for surge protection and plant monitoring. Systems and devices to monitor and

control the efficiency of photovoltaic parks are essential to ensure that the solar investment is a solid and efficient one. The Eos-Web is the ideal solution for installations up to 1 MW, while the Eos-Server is designed to control huge installations, in single and multiple locations.



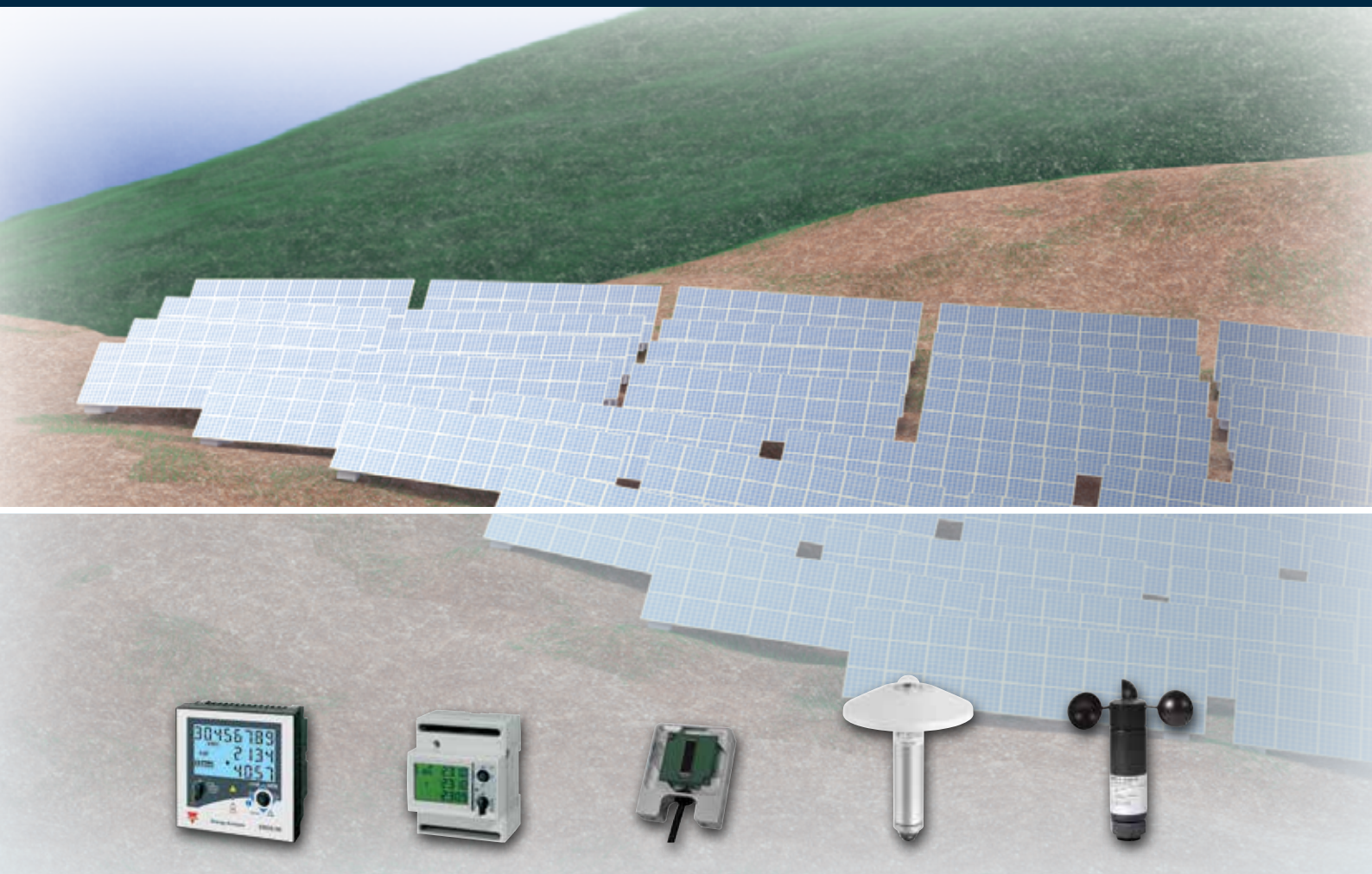

3-phase energy analysers

**EM26 96
EM24 DIN**

Interface protections

**PI-DIN
PI96**

Environmental sensors

**PVS-1
TEMPSOL
IKE2000**

Pyranometers

PVS-2A

**Anemometers
Wind vanes**

**DWS-V
DWS-D**

The Eos-Web is a web server gathering data from string monitoring units such as the Eos-Array, inverters and energy meters. All plant information is available simply by using the PC web browser and any Internet connection. The Eos-Array is a comprehensive string control system, suitable for

being integrated into both Eos-Web based solutions and standard SCADA software packages.

Based on glass optical fibre, the SIUFO is the solution for reliable communication where a traditional RS485 network cannot guarantee the correct level of immunity from

electromagnetic emissions from inverters, substations or power wiring. The installation of the VMU-O AT module ensures anti-theft control of PV modules by means of dedicated plastic optical fibre loops wired through the frame of the PV modules.

Carlo Gavazzi's flexible and modular PV monitoring architecture allows all the needs of investors, PV plant installers and maintenance services to be satisfied. Carlo Gavazzi application engineers and product specialists with solid expertise provide complete support, starting from project planning up to start up.



Renewable Energy

Photovoltaic small business, commercial and tracking



Surge arresters

**DSF
DSB
DSC**

Solar control solution

Eos-Array

Aggregation servers

**VMU-Y PV
Eos-Server**

Web server modules

**VMU-C
VMU-W**

Carlo Gavazzi provides everything for PV plant monitoring.

Eos-Array and Eos-Array Lite are systems composed of individual modular elements interacting with one another, providing efficient local control to the solar plant and ensuring effective information management in

medium or high power plants.

Carlo Gavazzi provides the Eos-Web, where the VMU-C unit is a local web-based data management system which gathers measurements and status information from one or more inverters to your PC or to a centralised cloud monitoring solution based on the Eos-

Server. With some rented roofs, wired internet is not available, but VMU-W solves this problem by using diffuse mobile communication.

Carlo Gavazzi energy meters and analysers measure the energy produced and provided to the grid or locally consumed.





Current transformers

**CTD
TADK**

3-phase energy analysers

**EM24 DIN
EM26 96**

Interface protections

**PI96
PI-DIN
DPC02/DPC72**

Environmental sensors

**PVS-1
PVS-2A
TEMPSOL**

Anemometers

DWS-V

These meters can be supplied with MID certification (Annex D).

The energy produced at low voltage by a PV plant can be measured with a MID approved meter such as the EM24 DIN or with the EM21 72D, the first 3-phase energy meter with detachable display. When supplying energy to the grid, it

is necessary to use a protection device installed between the generator and the power grid in order to grant the required voltage and/or frequency control.

Carlo Gavazzi's interface protections are the most compact solutions currently available on the market.

DPC72, PI-DIN and PI96 protection add a control function to frequency derivative and event recording and are equipped with a large display for local information readout and a serial port for remote readout.

The PI96, in addition to the interface protection functions, also provides an integrated energy meter with which it is possible to read: AC energy, active power, reactive power, AC currents, $\cos\phi$ etc.

The surge arresters for direct and indirect lightning discharge complete the Carlo Gavazzi portfolio for the photovoltaic market.



Renewable Energy

Photovoltaic residential systems



Solar control solution

Eos-Array Lite

1-phase energy meters

**EM10 DIN
EM11 DIN
EM111/EM112**

3-phase energy analysers

**EM21 72D
EM23 DIN/EM24 DIN
EM210/EM340**

Touch screen / Data logger

SmartHUB

PV plants in residential areas are mostly grid connected installations.

Modules are set on roofs and the energy produced by the PV modules is delivered to the inverters and then fed into the public grid. Carlo Gavazzi offers a wide range of devices and components for the configuration of the electrical solar plant. Separate interface protection can be achieved with our wide range of monitoring relays such as the PI-DIN, PI96, DPC and DPC02, according to national norm requirements.

For energy metering you can use the EM1xx single-phase energy meter series or the EM2xx and EM3xx series for 3-phase PV residential system applications, all with LCD data display.

The real-time energy usage measurements, made via our touch screen and data logger SmartHUB, will lead to more efficiency in energy consumption needs, resulting in significant energy savings. The system reads and logs the energy consumption of the whole installation or of a single load. Data can be accessed anytime by means of a web-server/web-app and shown as instantaneous values, or in the form of graphs and/or diagrams.

For protection against surges and overvoltages it is possible to use the DSB or DSF surge arresters for both DC and AC lines. In the case of direct lightning discharge protection, the DSC series can be used.



Off-grid systems

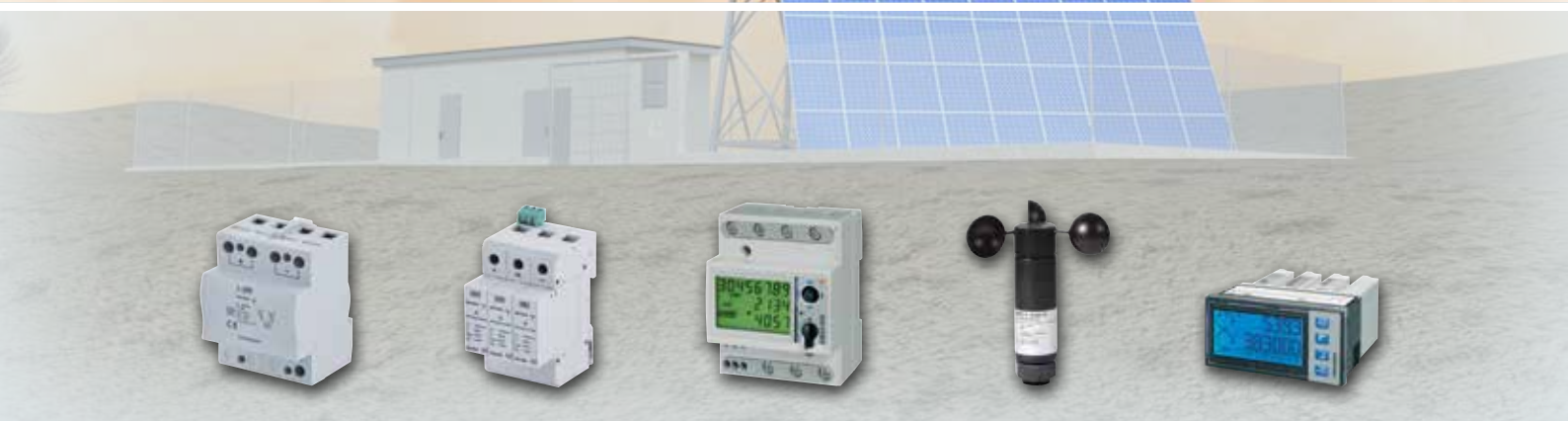

**Surge
arrester**

DSC

**Surge
arresters**

**DSB
DSF**

**3-phase
energy analysers**

**EM21 72D
EM23 DIN/EM24 DIN
EM210/EM340**

**Anemometers
Wind vanes**

**DWS-V
DWS-D**

**Digital modular
indicator**

UDM60



In remote areas renewable energy systems are gaining popularity, using stand-alone, off-grid plants with or without battery storage.

Carlo Gavazzi provides some additional components that can play an important role in such installations. DSC surge arresters provide protection for PV installations where an LPS (Lightning Protection System) is installed, hence subject to direct lightning strikes. This device is Type 1 and Type 2 approved.

DSB and DSF surge arresters can be used either on wind turbines or on PV installations. They are available for DC and AC networks and are Type 2, suitable for indirect lightning protection.

Wind speed and direction are extremely important parameters. Accurate measurements are necessary to keep the wind turbine structure under control. The Carlo Gavazzi anemometer DWS-V, with opto electronic detection, measures speed from 2 to 30 m/s. The sensor is designed with a dust and humidity seal, which makes the sensor impervious to all weather conditions. The micro-processor-based digital panel meter (UDM60), with its dual 6-dgt LCD indicator, displays the wind speed by measuring the input from the anemometer, while the energy produced is measured by a 3-phase energy analyser (EM21, EM23, EM24, EM210 or EM340).

Renewable Energy

The diagrams

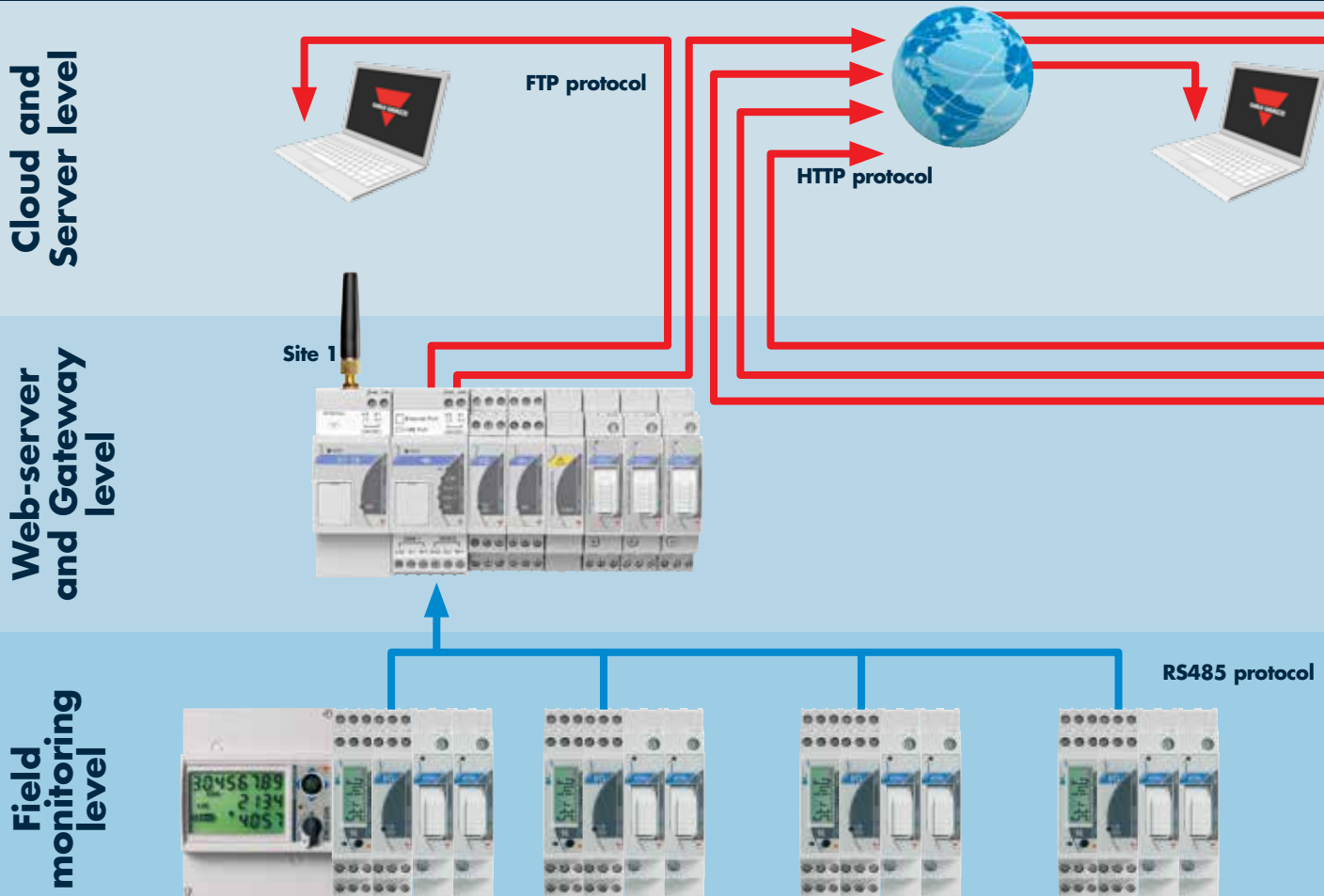

VMU-C PV into a Photovoltaic Monitoring architecture

VMU-C PV at a glance

The VMU-C PV is the core solution for effective Photovoltaic Monitoring in applications of all sizes. It collects measurements from Eos-Array string control units, energy meters and inverters; it stores information (variables and alarms) in its local database and displays it through its web-based graphical user interface. The whole system set-up and operation is possible via the VMU-C's web interface, without any external software. The VMU-C PV can exchange data with other systems by means of standard FTP/HTTP communication. Multi-site applications can be managed by adding either the Eos-Server or the VMU-Y PV to the VMU-C PV powered installations.



- No crash or compatibility problems due to different operative systems, different languages, libraries, etc.
- Improved IT security
- Application-focused software embedded inside industrial grade hardware: no need for a dedicated PC for monitoring
- On-site database
- Polling device, data-logger and Ethernet gateway in a single compact unit
- Modular solution for additional inputs/ outputs
- Optional modular modem for wireless Ethernet connections
- Scalability to multi-site applications by means of VMU-Y + Eos-Server solutions

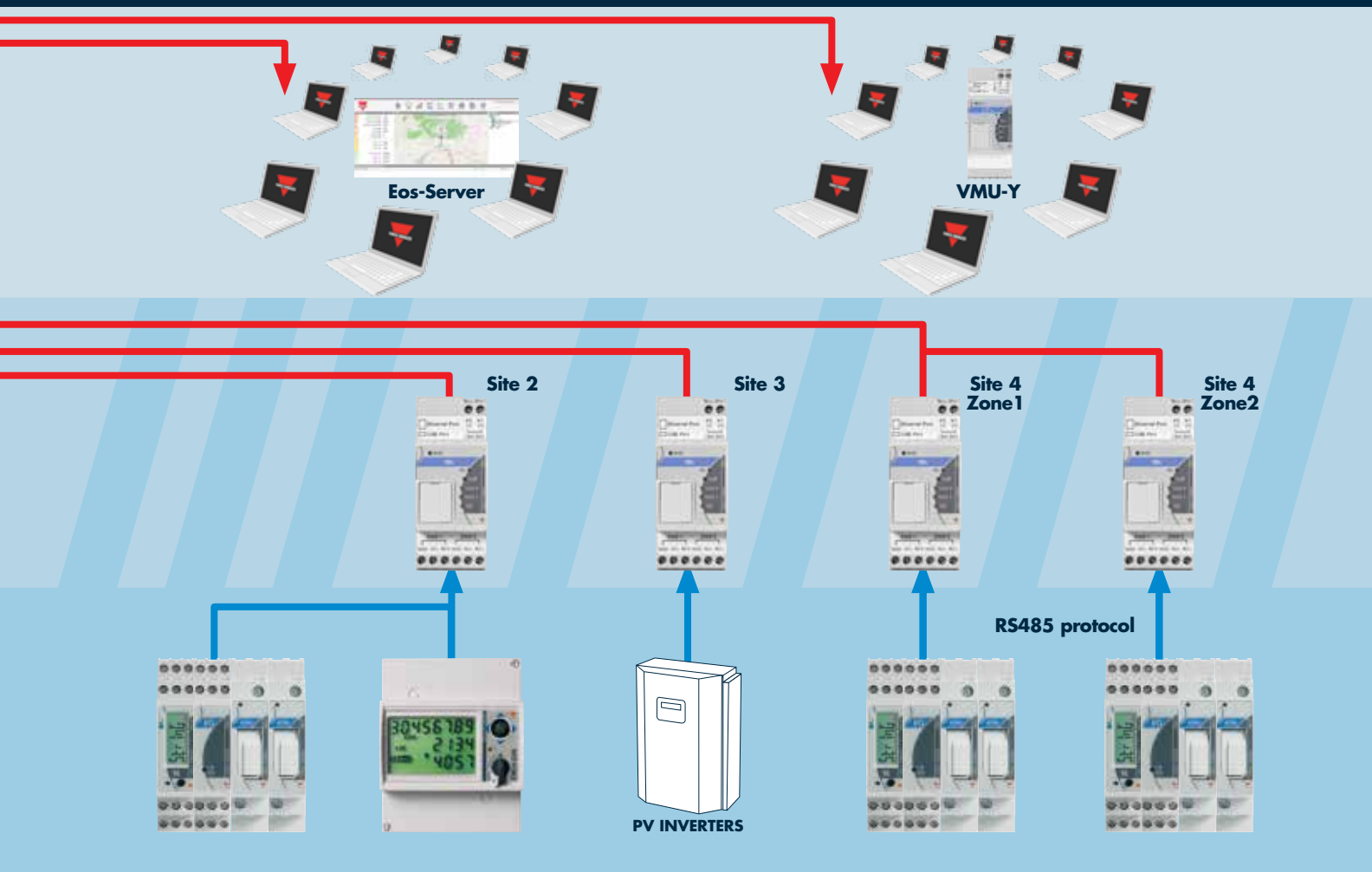

Eos-Server multi-site solution at a glance

- Multi-site management software based on Virtual Machine concept
- Flexible operation and set-up
- Reliable data communication with VMU-C PV
- Up to 100 geographically different sites can be managed with a single unit
- A single supplier for energy meters, gateways and data management solutions
- Scalable solution



VMU-Y PV multi-site solution at a glance

- Multi-site management software embedded in compact hardware
- Plug and play operation and set-up
- Reliable data communication with VMU-C PV
- Up to 10 geographically different sites can be managed with a single unit
- A single supplier for energy meters, gateways and data management solutions

Renewable Energy

Our product range

Solar control solution



Eos-Array / Eos-Array Lite

- Modular local control system for PV plant
- Up to 16 DIN module configuration
- Eos-ArraySoft, freeware configuration software
- Eos-Array can manage in addition to VMU-M unit up to: 1 VMU-P, up to 15 VMU-S and up to 7 VMU-O for a total of maximum 15 units

MAIN FEATURES

- The Eos-Array solution can be composed of: VMU-M, the master unit and data logger; VMU-S, the string controller; VMU-P, the environment variable unit and VMU-O, the I/O unit
- Eos-Array Lite is the answer to those photovoltaic applications where a less sophisticated monitoring solution is needed

Web server and datalogger



VMU-C PV (Eos-Web)

- Dimensions: 2 DIN modules
- Micro PC with web server and web service capability
- Data and event logging capability
- Internal 4GB memory and 16GB SDHC card back-up memory
- Variables shown as graphs and numbers in formatted tables
- All data exports on HTML format compatible with Excel or other spread sheets
- Management up to 11 Eos-Array, 11 inverters and 11 energy meters

MAIN FEATURES

- Efficiency calculation and control on different levels: string, BOS and Performance ratio and Yield indices
- Alarms control with automatic e-mailing and SMS management

3G Modem for VMU-C PV



VMU-W (Eos-Web)

- Dimensions: 2 DIN modules
- Internet access point when regular wired network is not available
- Mobile modem: GSM, GPRS, EDGE, UMTS, HSPA

MAIN FEATURES

- Suitable for use in combination with VMU-C PV
- Automatic dual or quad band setting (850 - 900 MHz, 1800 - 1900/2100 MHz)

Embedded aggregation server



VMU-Y PV

- 2-DIN size; DIN-rail mounting
- Multi-site PV monitoring management
- Power supply from 24 VDC (+/- 20%)
- 2 USB ports (for data backup and connection backup)
- 1 SD port (for backup)
- UL approved

MAIN FEATURES

- Photovoltaic plant/portfolio management
- Data analysis and benchmark
- Data and event logging
- Data aggregation in plants and virtual plants
- All data exported in format compatible with Excel or other spread sheets
- Alarms management
- Database replication up to 10 VMU-C PV

Cloud multi-site aggregation server



Eos-Server

- Software solution for photovoltaic plant management
- Multi-site PV monitoring management
- Flexible and scalable architecture
- VMware® Technology compatibility

MAIN FEATURES

- Photovoltaic plant/portfolio management
- Data analysis and benchmark
- Data and event logging
- Data aggregation in plants and virtual plants
- All data exported in format compatible with Excel or other spread sheets
- Alarms management
- Database replication up to 100 VMU-C PV

Touch screen / Data logger



SmartHUB

- Energy data logging from meters and PV inverters
- Colour touch screen 7" (BTM-T7) and 4.3" (BTM-T4)
- Remote access through web browsers
- Alarms management

MAIN FEATURES

- Wide screen display, 64 K colours
- 2 Ethernet port with integrated switch
- SD memory card slot
- USB host port
- Multistandard Modbus RTU serial communication port (selectable: RS485, RS422 or RS232)

Our product range

1-phase energy meters



EM10 DIN / EM11 DIN

- Dimensions: 1 DIN module
- Single-phase energy meters with direct connection
- Current input up to 32 A
- Class 1 (kWh) acc. to EN62053-1
- Pulse open collector output

MAIN FEATURES

- Direct measurement in a very compact housing to save space
- Suitable for measuring generated energy
- MID Annex D certification available

1-phase energy analysers



EM111 DIN

- Dimensions: 1 DIN module
- Backlit touch LCD
- Measurement of voltage, current, power, power factor and frequency
- Measuring inputs: 230 VAC, 45 A
- Bi-directional energy metering, 7 digits, cl. B (EN50470)

MAIN FEATURES

- Self-powered
- Pulse output or as an alternative: RS485 Modbus, M-Bus or Dupline®
- Sealable terminal covers
- CE, cULus

1-phase energy analysers



EM112

- Dimensions: 2 DIN modules
- Backlit touch LCD
- Measurement of voltage, current, power, power factor and frequency
- Measuring inputs: 230 VAC, 100 A
- Bi-directional energy metering, 8 digits, cl. B (EN50470)

MAIN FEATURES

- Self-powered
- Pulse output or as an alternative: RS485 Modbus, M-Bus or Dupline®
- Sealable terminal covers
- CE, cULus

3-phase energy analyser



EM26 96

- Dimensions: 96 x 96 mm housing, only 45 mm behind the panel
- 3-phase energy meters with CT/VT connection
- Primary current input: 5 A
- Class 1 (kWh) acc. to EN62053-1
- Modbus communication port

MAIN FEATURES

- Energy analyser in a very compact housing to save space
- Suitable for measuring generated and consumed energy
- MID Annex D certification available

3-phase energy meters/analysers



EM23 DIN / EM24 DIN

- Dimensions: 4 DIN modules
- 3-phase energy meters with direct connection
- Current input up to 65 A
- Class 1 (kWh) acc. to EN62053-1
- Pulse open collector output
- Modbus communication port

MAIN FEATURES

- Direct measurement in a very compact housing to save space
- Suitable for measuring generated and consumed energy (EM24)
- MID Annex D certification available

3-phase energy analysers



EM340

- Dimensions: 3 DIN modules
- Backlit touch LCD
- Measurement of voltage, current, power, power factor and frequency
- Bi-directional energy metering on 2 8-digit counters, cl. B (EN50470)
- Measuring inputs: 3 x 230 (400)VAC, 65 A
- Power supply: Self-powered

MAIN FEATURES

- Pulse output or as an alternative: RS485 Modbus, M-Bus or Dupline®
- Sealable terminal covers
- CE, cULus

Renewable Energy

Our product range

3-phase energy analysers



EM21 72D

- Dimensions: 4 DIN modules or 72x72mm
- Installation: DIN-rail or panel mounting in a single product
- 3-phase energy meters with CT/VT connection
- Measurement of voltage, current, power, power factor and frequency
- Self-powered
- Pulse output
- RS485 Modbus RTU

MAIN FEATURES

- CE, cULus
- MID Annex D certification available
- Sealable terminal covers
- Very compact housing to save space

3-phase energy analysers



EM210

- Dimensions: 4 DIN modules or 72x72mm
- Installation: DIN-rail or panel mounting in a single product
- 3-phase energy meters with CT/VT connection
- Measurement of voltage, current, power, power factor and frequency
- Self-powered
- Pulse output
- RS485 Modbus RTU, high speed (up to 115kbps)

MAIN FEATURES

- CE, cULus
- Sealable terminal covers
- Very compact housing to save space

Current transformers



CTD / TADK

- CTD: currents from 40 to 4000 A TADK2: 1-250 A
- Removable panel fixing clips
- DIN rail and panel mounting facility (TAD...)
- Double screw terminals (CTD)
- Sealable covers
- Case: ABS, self-extinguishing level UL 94 V-0
- Precision class: 0.5

MAIN FEATURES

- Wound primary / solid core or split-core
- Compliance with EN60044-1 regulations
- Removable DIN rail mounting holder

Digital modular indicators



UDM60 / UDM40 / USC

- Dimensions: 48 x 96 x 105 mm
- Modular Controller for pulse signals (UDM60)
- Dual 6-DGT
- 0.001% RDG basic accuracy
- NPN, PNP, NAMUR, TTL, Pick-up, free of voltage contacts and AC signal inputs
- Multi-input modular instrument (UDM40, USC)
- 4-DGT three colour LED
- 0.1% RDG basic accuracy
- Dual rate, speed, frequency and period measurement (0.001 Hz to 50 kHz)

MAIN FEATURES

- Digital panelmeter for current, voltage, temperature, resistance, rate, frequency, speed and period measurements

Interface protections



PI96

- Dimensions: 96 x 96 mm panel mounting housing
- Inputs for local/remote control, alarms and aux.
- Outputs for DDI and backup relay
- Measure V, A, Hz, kWh, kVarh
- Auxiliary power supply AC and DC

MAIN FEATURES

- Menu and logger navigation by touch pad
- Self-protection components, "Power Save" mode for limit consumption
- Certified according to CEI 0-21 2012-06 technical norm
- Possibility of other recommendation/implementation

Interface protections



PI-DIN

- Dimensions 90 x 71 x 66 mm
- Interface protection monitoring relay for 1-phase or 3-phase systems with or without neutral
- Voltage and frequency protection
- 4 inputs (CEI-021) or 2 inputs (VDE4105), 2 outputs
- Measure V, Hz
- Auxiliary power supply 230 VAC or 24 VDC
- Data logger with 10 last events logging

MAIN FEATURES

- Settings, menu and logger navigation by means of front joystick
- Password protected settings, Dual Function Alarm LED
- Certified according to Italian CEI 0-21 2012-06 and V1:2012-12 and German VDE-AR-N-4105:2011-0
- Anti-islanding on VDE model

Our product range

Interface protections



DPC02DM...B005

- Dimensions: 45 x 80 x 99.5 mm
- DIN rail mounting
- Power: 208 to 240 VAC or 380 to 415 VAC
- Protection degree: IP20
- Output: programmable relays 2 SPDT N.E. or 1 DPDT N.E.

MAIN FEATURES

- One-phase and three-phase relays for monitoring maximum and minimum voltage and frequency, phase sequence and phase failure. It checks that frequency and voltage are within the limits set by the utility

Interface protections



DPC72DM

- Dimensions: 90 x 71 x 65 mm, 4 DIN module
- DIN rail mounting — sealable housing
- Values and intervention time programming
- Serial port RS485 Modbus RTU
- Protection degree: IP50
- Output: 1 DPDT N.E.

MAIN FEATURES

- One-phase and three-phase relays for monitoring maximum and minimum voltage and frequency, phase sequence and phase failure. It checks that frequency and voltage are within the limits set by the utility
- Record of the last 10 events (date, time and reason for the event)

Switching power supply



SPM

- DIN rail housing
- Universal input 90-264 VAC / 120- 370 VDC
- Single phase and battery charger versions available
- Approvals/Marks: UL, cUL listed and TÜV/CE approved

MAIN FEATURES

- Operating temperature w/o derating -25°C to +60°C
- Short circuit and Overload protection
- High efficiency (up to 89%)

Surge arresters



DSC

- Dimensions: 90 x 72 x 70 mm
- Class I and II
- Protective element: High Energy MOV
- High surge discharge rating: Iimp = 12.5 kA per pole
- Housing: compact design

MAIN FEATURES

- Specifically designed for PV installations with or without LPS (Lightning Protection System)
- Location of use: photovoltaic system - PV module side

Surge arresters



DSB / DSF

- Dimensions: 90 x 36 x 72 mm
- Class II
- Available for PV and AC installations
- Models for communication lines
- Optional remote monitoring
- For DIN rail mounting

MAIN FEATURES

- NO backup fuse required
- Appr. Acc. to IEC61643-11 and UTE C61-740-51
- Complies with prEN50539-11

Surge arresters



DSB51XXDP

- Dimensions: 90 x 12 x 71.5 mm DIN-rail housing
- 15 VDC nominal voltage
- 10 kA Inom, 20 kA Imax
- Rated spark overvoltage 184V to 276V
- C1/C2/C3 according to IEC 61643-21

MAIN FEATURES

- Designed for Dupline® communication lines
- Three stage topology with dual GDT
- Socket with replaceable cartridge

Renewable Energy

Our product range

Temperature sensors



TEMP SOL / IKE20001K

- Temperature Pt100 or Pt1000 (TEMP SOL)
- Temperature Pt1000 (IKE20001K)
- $\pm 0.3^{\circ}\text{C}$ connection type
- 2 wire connection type

MAIN FEATURES

- Specifically design to measure the temperature of PV panels (TEMP SOL)
- For air temperature measurement in PV plants (IKE20001k)

Irradiation sensors



PVS-1

- Dimensions: 57 x 48 x 15 mm (not including clamp)
- Sensor type: crystalline silicon cell
- No need for external power supply (self-powered)
- Long lasting 3% accuracy, thanks to a special antiageing treatment
- Calibration process according to IEC 60904-2 and 60904-4
- Two available versions: 4-20 mA output / 0-80 mV output

MAIN FEATURES

- Long life rugged aluminium case
- UV resistant resin encapsulation
- Fast installation, thanks to the clamping system designed to easily fit the photovoltaic module's frame

Pyranometers



PVS-2A

- Dimensions: 162 x 215 x 40 mm (not including clamp)
- 2nd class thermopile pyranometer
- 4-20 mA output for reliable connections
- Calibration certificate according to ISO 9847

MAIN FEATURES

- Compact and rugged IP67 aluminium case
- Compliant with WMO (World Meteorological Organization) for environmental monitoring
- Compliant with ISO9060 and IEC17025 for photovoltaic monitoring

Anemometers / Wind vanes



DWS-D / DWS-V

- Rotor size: 145 mm
- PNP & NPN open collector output in one unit
- Rotor: black painted stainless steel
- Wind vane for relative wind direction (0 and 90 degree internals -DWS-D-DAC13) (+/- 7 degree of wind direction, left/right wind indication DWS-D-DDC13)
- Anemometer with opto-electronic detection (DWSV...)
- Measuring range 2 to 30 m/s
- Current source output 10 to 28 VDC supply

MAIN FEATURES

- Opto-electronic detection
- All inputs and outputs are protected against reverse polarity and transients
- Dust sealed stainless steel ball bearing

Accessory modules



SIUFO

- 4-DIN size; DIN-rail mounting
- SIUFO1: RS485 to single loop fibre optic conversion
- SIUFO2: RS485 to double loop fibre optic conversion
- Power supply from 12 to 18VAC or from 10 to 24VDC

MAIN FEATURES

- MODBUS/JBUS(RTU) compliant
- Wire to optical fiber and optical fiber to wire conversion
- Status LED
- Compatible with Multimode Optical fiber
- Up to 160 transceivers on the same bus
- Up to 247 Modbus addresses, automatically managed
- Baudrate and RS485 parameters selectable by dip-switches

Accessory modules



VMU-O AT/VMU-AT

- Eos-Array standard expansion I/O module (VMU-O AT)
- Plastic optical fiber sensor (VMU-AT)
- Up to 3 VMU-AT modules per VMU-O AT
- Up to 1 VMU-O AT per Eos-Array

MAIN FEATURES

- Plastic optical fiber loops (up to 200 m) to protect PV modules
- Plug'n play set-up (optical fiber cutter included)
- Anti-theft alarm events integrated in the Eos-Array and VMU-C PV solutions
- 3 digital inputs, 1 relay output (VMU-O AT)
- 1 optical fiber loop, digital output (VMU-AT)



OUR SALES NETWORK IN EUROPE

AUSTRIA - Carlo Gavazzi GmbH
Ketzerergasse 374,
A-1230 Wien
Tel: +43 1 888 4112
Fax: +43 1 889 10 53
office@carlogavazzi.at

FRANCE - Carlo Gavazzi Sarl
Zac de Paris Nord II, 69, rue de la Belle Etoile,
F-95956 Roissy CDG Cedex
Tel: +33 1 49 38 98 60
Fax: +33 1 48 63 27 43
french.team@carlogavazzi.fr

ITALY - Carlo Gavazzi SpA
Via Milano 13,
I-20020 Lainate
Tel: +39 02 931 761
Fax: +39 02 931 763 01
info@gavazziacbu.it

SPAIN - Carlo Gavazzi SA
Avda. Iparraguirre, 80-82,
E-48940 Leioa (Bizkaia)
Tel: +34 94 480 4037
Fax: +34 94 431 6081
gavazzi@gavazzi.es

BELGIUM - Carlo Gavazzi NV/SA
Mechelsesteenweg 311,
B-1800 Vilvoorde
Tel: +32 2 257 4120
Fax: +32 2 257 41 25
sales@carlogavazzi.be

GERMANY - Carlo Gavazzi GmbH
Pfnorstr. 10-14
D-64293 Darmstadt
Tel: +49 6151 81000
Fax: +49 6151 81 00 40
info@gavazzi.de

NETHERLANDS - Carlo Gavazzi BV
Wijkermeerweg 23,
NL-1948 NT Beverwijk
Tel: +31 251 22 9345
Fax: +31 251 22 60 55
info@carlogavazzi.nl

SWEDEN - Carlo Gavazzi AB
V:a Kyrkogatan 1,
S-652 24 Karlstad
Tel: +46 54 85 1125
Fax: +46 54 85 11 77
info@carlogavazzi.se

DENMARK - Carlo Gavazzi Handel A/S
Over Hadstenevej 40,
DK-8370 Hadsten
Tel: +45 89 60 6100
Fax: +45 86 98 15 30
handel@gavazzi.dk

GREAT BRITAIN - Carlo Gavazzi UK Ltd
4.4 Frimley Business Park,
Frimley, Camberley, Surrey GU16 7SG
Tel: +44 1 276 854 110
Fax: +44 1 276 682 140
sales@carlogavazzi.co.uk

NORWAY - Carlo Gavazzi AS
Melkeveien 13,
N-3919 Porsgrunn
Tel: +47 35 93 0800
Fax: +47 35 93 08 01
post@gavazzi.no

SWITZERLAND - Carlo Gavazzi AG
Verkauf Schweiz/Vente Suisse
Sumpfstrasse 3,
CH-6312 Steinhausen
Tel: +41 41 747 4535
Fax: +41 41 740 45 40
info@carlogavazzi.ch

FINLAND - Carlo Gavazzi OY AB
Petaksentie 2-4,
FI-00661 Helsinki
Tel: +358 9 756 2000
Fax: +358 9 756 20010
myynti@gavazzi.fi

PORTUGAL - Carlo Gavazzi Lda
Rua dos Jerónimos 38-B,
P-1400-212 Lisboa
Tel: +351 21 361 7060
Fax: +351 21 362 13 73
carlogavazzi@carlogavazzi.pt

OUR SALES NETWORK IN THE AMERICAS

USA - Carlo Gavazzi Inc.
750 Hastings Lane,
Buffalo Grove, IL 60089, USA
Tel: +1 847 465 6100
Fax: +1 847 465 7373
sales@carlogavazzi.com

CANADA - Carlo Gavazzi Inc.
2660 Meadowvale Boulevard,
Mississauga, ON L5N 6M6, Canada
Tel: +1 905 542 0979
Fax: +1 905 542 22 48
gavazzi@carlogavazzi.com

MEXICO - Carlo Gavazzi Mexico S.A. de C.V.
Calle La Montaña no. 28, Fracc. Los Pastores
Naucalpan de Juárez, EDOMEX CP 53340
Tel & Fax: +52.55.5373.7042
mexicosales@carlogavazzi.com

BRAZIL - Carlo Gavazzi Automação Ltda.
Av. Francisco Matarazzo, 1752
Conj 2108 - Barra Funda - São Paulo/SP
Tel: +55 11 3052 0832
Fax: +55 11 3057 1753
info@carlogavazzi.com.br

OUR SALES NETWORK IN ASIA AND PACIFIC

SINGAPORE - Carlo Gavazzi Automation
Singapore Pte. Ltd.
61 Tai Seng Avenue
#05-06 UE Print Media Hub
Singapore 534167
Tel: +65 67 466 990
Fax: +65 67 461 980
info@carlogavazzi.com.sg

MALAYSIA - Carlo Gavazzi Automation
(M) SDN. BHD.
D12-06-G, Block D12,
Pusat Perdagangan Dana 1,
Jalan PJU 1A/46, 47301 Petaling Jaya,
Selangor, Malaysia.
Tel: +60 3 7842 7299
Fax: +60 3 7842 7399
sales@gavazzi-asia.com

CHINA - Carlo Gavazzi Automation
(China) Co. Ltd.
Unit 2308, 23/F.,
News Building, Block 1, 1002
Middle Shennan Zhong Road,
Shenzhen, China
Tel: +86 755 83699500
Fax: +86 755 83699300
sales@carlogavazzi.cn

HONG KONG - Carlo Gavazzi
Automation Hong Kong Ltd.
Unit 3 12/F Crown Industrial Bldg.,
106 How Ming St., Kwun Tong,
Kowloon, Hong Kong
Tel: +852 23041228
Fax: +852 23443689

OUR COMPETENCE CENTRES AND PRODUCTION SITES

DENMARK - Carlo Gavazzi Industri A/S
Hadsten

MALTA - Carlo Gavazzi Ltd
Zejtun

ITALY - Carlo Gavazzi Controls SpA
Belluno

LITHUANIA - Uab Carlo Gavazzi Industri Kaunas
Kaunas

CHINA - Carlo Gavazzi Automation
(Kunshan) Co., Ltd.
Kunshan

HEADQUARTERS

Carlo Gavazzi Automation SpA
Via Milano, 13
I-20020 - Lainate (MI) - ITALY
Tel: +39 02 931 761
info@gavazziautomation.com



CARLO GAVAZZI
Automation Components

Energy to Components!

www.gavazziautomation.com

