

# VAF & kWh Meters

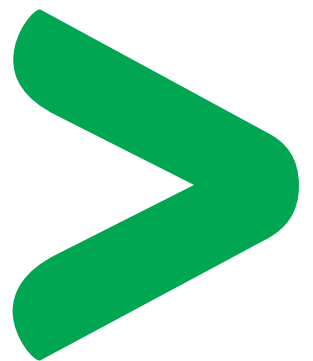

Quick and easy  
installation



Meter for all electrical  
panels



Power energy  
monitoring

**Schneider**  
Electric™

# VAF & kWh Meters

## Functions and characteristics



DM6000/ EM1000 series



EM1200

576 720.000  
W VA PF

Backlit LCD display



Smart line indicators

The Conzerv™ DM6XXX & EM1XXX series meter offers all the basic measurement capabilities required to monitor an electrical installation in 96 x 96 mm units

Characterized by their rugged construction, compact size, and low installation costs, these state-of-the-art meters are ideal for control panels, motor control centers and genset panels

The DM6XXX & EM1XXX series are available in four different versions, each one to best fit specific applications

DM6100	VAF, PF meter with 1.0% accuracy
DM6100	VAF, PF meter with 0.5% accuracy
DM6300	VAF, PF meter with port & 1.0% accuracy
DM6300	VAF, PF meter with port & 0.5% accuracy
EM1000	Energy meter with pulse output & 1.0% accuracy
EM1000	Energy meter with pulse output & 0.5% accuracy
EM1200	Energy meter with RS485 port & 1.0% accuracy
EM1200	Energy meter with RS485 port & 0.5% accuracy
EM1220	VAF, PF, Power & Energy meters with RS485 port & 1.0% accuracy
EM1220	VAF, PF, Power & Energy meters with RS485 port & 0.5% accuracy

### Applications

Energy billing  
Load balancing and optimization  
Electrical load monitoring  
Gensets, test benches, and laboratories

### Main characteristics

#### Fast in line view:

Elegant single row, backlit LCD display  
Three parameters, name and value at one glance  
Direct reading of primary values - no multiplication factor  
Kilo, mega and giga indications with autoscaling capability  
User selectable default display page and lock

#### High Resolution

RMS values: Three digit  
Integrated values: Energy values, nine digit (2 digits after decimal)

#### Intuitive function keys

Four smart keys for easy navigation, display pages expand vertically, much like the directory or explorer tree displayed on any computer

#### Auto-scrolling

Allows you to monitor a group of parameters sequentially without any manual key operation.

#### Secure settings

Unique password protection for the set-up parameters.

#### Smart line indicators

Helps to check the presence of input voltage (healthy phase)

#### Universal aux supply

Wide aux range 44-277V ac/dc

#### Communicator

Optional RS 485 communication port with Modbus RTU. Can be integrated with various Schneider SCADA softwares (ION™ Enterprise, Power Logic™ SCADA, Vijeo™ Citect and Vista) and also third party SCADA / BMS for Energy & Building management studies

# VAF & kWh Meters

## Functions and characteristics

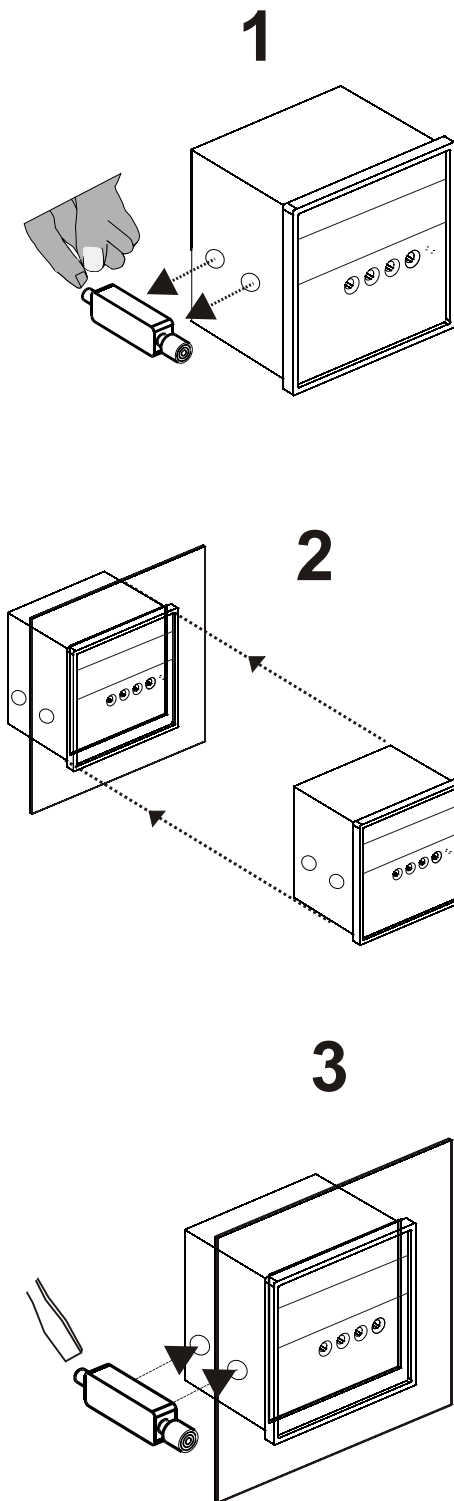

Parameter		EM1000	EM1200	EM1220
RMS	VLL-V12V23 V31 VLN-V1 V2V3			•
	A A1 A2A3			•
	F			•
	PF PF1 PF2 PF3	•	•	•
	WW1 W2 W3 / VAVA1 VA2VA3 / VAR VAR1 VAR2 VAR3	•	•	•
INTG & OLD	KWh / KVAh / KVARh	•	•	•
	Run.h	•	•	•
	On.h	•	•	•
	INTR	•	•	•
POP		•		
RS-485 communication			•	•
Class 0.5 Accuracy		□	□	□
Class 1.0 Accuracy		□	□	□

**NOTE:** • Standard □ Option specified while ordering

The power/energy parameters are user-programmable. Only one power related parameter will be available at a time in the meter.

Part Numbers	
VAF meter	Part number
DM6100 Class 1.0 accuracy	30002567
DM6100 Class 0.5 accuracy	30002569
DM6300 Class 1.0 accuracy with RS485	30002566
DM6300 Class 0.5 accuracy with RS485	30002570
kWh meter	
EM1000 Class 1.0 accuracy with POP	30002568
EM1000 Class 0.5 accuracy with POP	30002571
EM1200 Class 1.0 accuracy with RS 485	30002565
EM1200 Class 0.5 accuracy with RS 485	30002572
VAF, PF & Power and Energy meter	
EM1220 Class 1.0 accuracy RS485 port	30002993
EM1220 Class 0.5 accuracy RS485 port	30002994

1. Remove mounting clamps from the digital meter.
2. Gently slide the digital meter through the cut-out.
3. Put the mounting clamps back in the digital meter and tighten the mounting clamp screws.

# VAF & kWh Meters

## Functions and characteristics

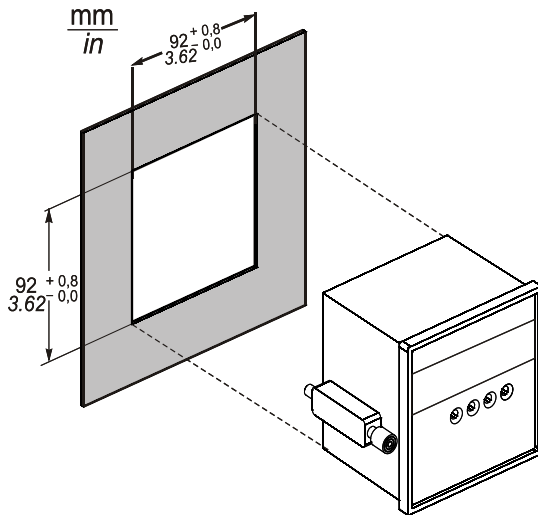

DM 6XXX / EM 1XXX series meter panel cut-out



Rear view

### Electrical characteristics

Type of measurement		True rms	
Measurement accuracy	Voltage	±1% of Full Scale for DM6XXX CI 1.0 meter ±0.5% of Full Scale for DM6XXX CI 0.5 meter	
	Current	±1% of Full Scale for DM6XXX CI 1.0 meter ±0.5% of Full Scale for DM6XXX CI 0.5 meter	
Power & Energy	Active/ Apparent	±1.0% of Full Scale for EM1XXX CI 1.0 meter ±0.5% of Full Scale for EM1XXX CI 0.5 meter	
	Reactive	±2.0% of Full scale for EM1XXX CI 1.0 meter ±1.0% of Full scale for EM1XXX CI 0.5 meter	
Data update rate		One second	
Input-voltage characteristics	Inputs	V1, V2, V3, VN	
	Measured voltage	80 to 480 VAC L.L. without PTs Up to 999 kV with external PTs	
	Permissible overload	480VLL with full accuracy, 750VLL continuous	
	Burden	0.2 VA per phase max	
	Frequency	50Hz ±5%	
Input-current	CT ratings	Primary	1 A to 99.0 kA
		Secondary	1A / 5A
	Measurement range	50 mA to 6A (Accuracy applicable from 250mA to 6A)	
	Permissible overload	5A: 6A with accuracy, 10A continuous 1A: 1.2A with accuracy, 10A continuous	
Impedance	< 0.1 ohm		
Burden	0.2 VA per phase max		
Auxiliary supply (control power)	44 to 277V AC 50Hz ±5%		
	44 to 277V DC		
Comm.	Pulse output ( EM 1000 )	24Vdc, Pulse width programmable from 50 to 500ms	
	RS 485	2 terminals, Modbus RTU, Baud rate, selectable from 4800 to 19200	

### Mechanical characteristics

Weight	0.500 kg (shipping), 0.400 kg (unpacked)
IP degree of protection	Front: IP 51; Rear: IP 40
Dimensions	Bezel: 96 x 96 mm Depth: 80 mm behind bezel Panel cutout: 92 x 92 mm

### Environmental characteristics

Operating temperature	-10 to +60 °C (14 to 140 °F)
Storage temperature	-25 to +70 °C (-13 to 158 °F)
Humidity	5 to 95 % RH non-condensing
Altitude	2000 m
Measurement category	III
Pollution degree	2
Protection class	2

### Electromagnetic compatibility

Electrostatic discharge	As per IEC61000-4-2*
Fast transient	As per IEC61000-4-4*
Immunity to surge waves	As per IEC61000-4-5*
Impulse voltage	As per IEC60060*
Conducted and radiated emissions	CISPR 11 Class A

### Safety and standards

Construction	Self extinguishable V0 plastics; Double insulation at user accessible area
--------------	---

\*As per IEC61326-1

DM6XXX can be used in both 50Hz & 60Hz NW frequency

# VAF & kWh Meters

## Wiring Diagrams

(for illustration only - refer quick installation for more details)

### 3-phase 4-wire star/ye connection

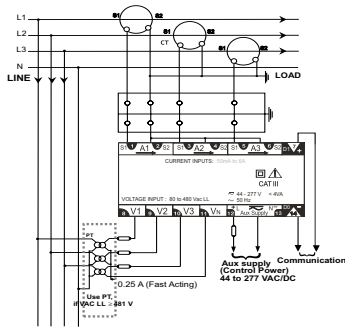

### 2-phase 3-wire connection

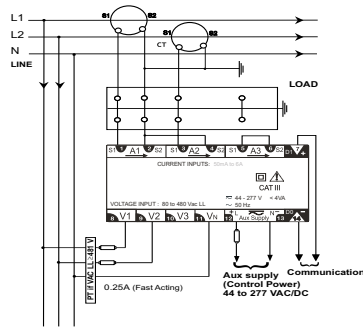

### 3-phase 3-wire delta connection

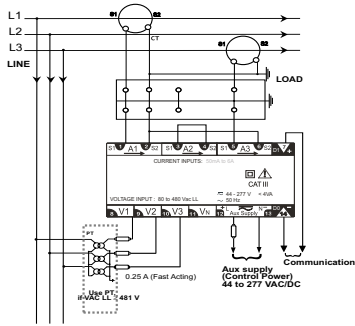

### Single phase connection

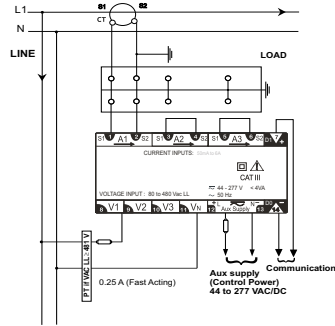

### 3-phase 3-wire open delta connection

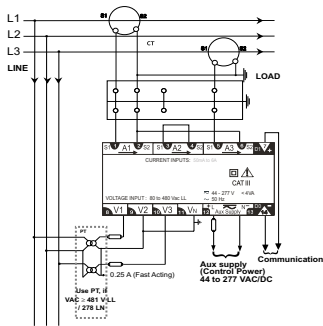



Make the most of your energy<sup>SM</sup>

**Schneider Electric India Pvt. Ltd.**

**Corporate office**

9th Floor, DLF Building No.10, Tower C, DLF Cyber City,  
Phase II, Gurgaon - 122002, Haryana  
Tel: 0124 3940400, Fax: 0124 4222036  
[www.schneider-electric.com](http://www.schneider-electric.com)

**Customer Care Centre :**

Toll-free numbers: 1800 103 0011, 1800 425 4272  
General number: 0124 4222040,  
Email: [customercare.in@schneider-electric.com](mailto:customercare.in@schneider-electric.com)

