



**MIAL**<sup>®</sup>  
**INSTRUMENTS PVT. LTD.**  
*Measuring & Beyond*

# MRL

MIAL RADAR LEVEL METER



| Measuring & Beyond



[www.mialinstruments.com](http://www.mialinstruments.com)

## Mial Radar Level Meter

### DESCRIPTION

The Frequency Modulated Continuous Wave (FMCW) is utilized in Mial radar level instruments. In this system, the antenna transmits a high-frequency, frequency-modulated radar signal. The frequency of the transmitted radar signal increases linearly. After transmission, the radar signal is reflected by the dielectric material that is being measured and received back by the antenna.

Simultaneously, the difference between the frequencies of the transmitted signal and the received signal is directly proportional to the measured distance. Consequently, the distance is calculated using the spectrum derived from the frequency difference obtained through analog-to-digital conversion and Fast Fourier Transform (FFT).

### APPLICATIONS

#### Tank Level Measurement:

Ideal for accurately measuring liquid levels in small storage tanks, even with tight spaces and minimal blind areas.

#### Industrial Process Monitoring:

Provides precise level measurement for a wide range of mediums, including chemicals, oils, and water in various industrial applications.

#### Metrology and Calibration:

Suitable for high-precision measurement tasks requiring millimeter-level accuracy, such as metrology labs and calibration processes.

#### Non-Standard Media Measurement:

Effective for measuring materials with low dielectric constants ( $\epsilon_r > 1.6$ ), such as certain oils, solvents, or powders.

#### Corrosive Environments:

Perfect for use in environments where resistance to corrosion is critical, thanks to the durable PTFE lens antenna.

**Bulk Storage Systems:** Enhances measurement accuracy in large bulk storage tanks, ensuring reliable monitoring of material levels in various industries



**MRL – Mial radar Level Meter**

## FEATURES

### High-Frequency Antenna:

Compact antenna with a small beam angle, wide bandwidth, and high resolution ensures accurate measurement even in low dielectric constant media ( $\epsilon_r > 1.6$ ).

### Robust Construction:

Built to withstand high temperatures and pressures, making it suitable for harsh applications such as reactors, large storage tanks, and guided-wave piping systems.

### Exceptional Process Stability:

Provides reliable and stable readings even in tough environments with heavy dust, vapors, agitation, or interference from heating rods.

### Extended Measurement Range:

Offers a significantly larger performance range, making it a superior replacement for traditional 26 GHz radar technology.

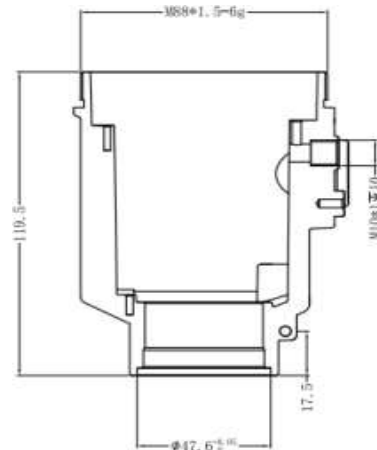
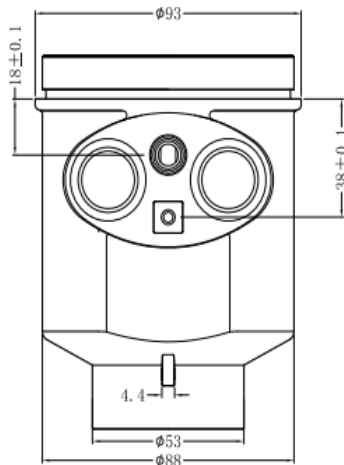

## BENEFITS OF MIAL RADAR LEVEL METER

- High accuracy even in low dielectric media.
- Low maintenance due to rugged and durable design.
- Stable performance in dust, vapors, and turbulent conditions.
- Suitable for long-range level measurement in large tanks.
- Advanced technology offering better performance than traditional 26 GHz radar.

## MRL Dimensions

# MRL specifications\*

## Measurement Principle

FMCW (Frequency Modulated Continuous Wave) Radar

## Accuracy

±3mm

## Resolution

1mm

## Range

0-30m

## Process Connection

Standard : Threaded (BSP 1 1/2")

Optional: Flanged (under DN 65)

## Beam Angle

3° or 8°

## Power supply range

24V DC

Use 2-amp SMPS when employing AC power

## Electrical Interface

M20×1.5

## Communication mode

MODBUS

HART

## Outputs

2-wire 4~20mA +RS485

## Cable inlet/plug

1 blind plugged M20×1.5

1 M20 XL.5 cable inlet

## Frequency range

W-band [80 GHz]

## Terminal

The cross section of the wire is 2.5mm<sup>2</sup>

## Fault signal

The current output is unchanged ;

21mA ; 3.6mA

## Integration time

(0 to 20)s, adjustable

## Antenna form

Horn or lens antenna

## Process pressure

-1 to 20 bar

## Ambient storage temperature

-40~+80°C

## Process temperature

Threaded or Flanged Under DN65 Ideally Do Not Reach Over 80°C

Data Will Drifting (Either Higher Or Lower).

Flanged Over DN65 Can Reach Under 200°C.

## Process Connection

Standard :BSP 1 1/2", BSP 3 1/2",

Optional : Flange DN40-DN200 (Universal Flange Could Do DN250)

## Materials

Enclosure : Cast Aluminum Alloy

Threaded : (Standard -PTFE) / (Optional -SS304)

Flange : (Standard -PTFE) /(Optional - SS304)

## Shell

Standard: Cast aluminum

Optional: Stainless steel

## Seal between housing and housing

Silicone rubber

## Shell window

Polycarbonate

## Ground terminal

Stainless Steel

## Blind Zone

*Depending On Low Level Adjustments*

Blind zone is 0.15 meter for the sensors

having capacity of 30 m measuring

range.

*Install Height Under 20m Barely No Blind Zone (Normally there is a fix tube for flange install at least 0.3m around already.)*

## Adjustment time

About 1 second (depends on parameter Settings)

## Relative humidity

< 95%

## Shock-proof

Mechanical vibration 10m/s<sup>2</sup>, (10 ~ 150)Hz

## Class of protection

Display Head IP65, Probe IP68.

\*Specifications are subject to change without prior notice

## ORDERING CODE

### Meter Model Coding = MRL-AA- B-C-D-E-F-G

**Model**

Mial radar Level meter = MRL

**AA=Measuring**

30=30m

**B= Process Connection**

1 = Threaded

2 = Flanged

**C =Power Supply**

1 = 24 VDC

**D=Signal Output**

1 = Two-wire 4~20 mA,  
RS485 Modbus &  
HART

**E= Shell material**

1 = Cast Aluminum (standard)

2 = SS304

3 = SS316

**F = Explosion Proof**

1 = YES

2 = NO

**G = Structure**

1 = Integral

All future orders will adhere to the standard specifications outlined in the order code, ensuring consistency and quality across items



**MIAL**®  
**INSTRUMENTS PVT.LTD.**  
*Measuring & Beyond*

USA OFFICE ADDRESS : DOWNTOWN REPUBLIC CENTER , 325 N. ST.PAUL STREET, SUITE 3100,DALLAS 75201 ,TEXAS,USA FACTORY 1 ADDRESS :  
856/6 GIDC MAKARPURA, VADODARA, GUJARAT-390010  
FACTORY 2 : 195, AATMIYA BROOKFIELDZ INDUSTRIAL PARK, POR, UNTIYA KAJAPUR, VADODARA, GUJARAT - 391243  
Mob : +91 9913449547 | +91 9913449548 e-mail :info@mialinstruments.com