

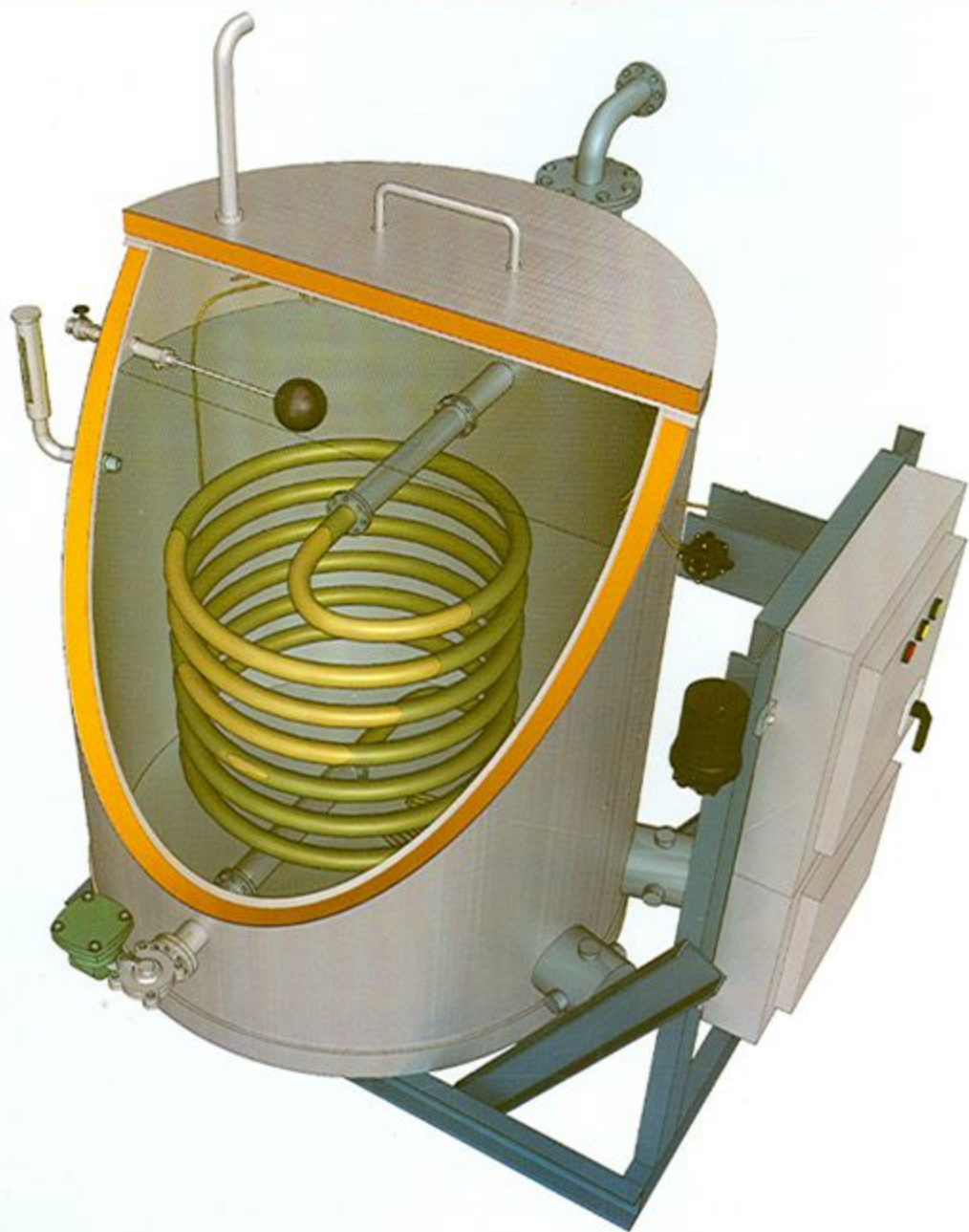

OIL & GAS PLANT ENGINEERS (I) PVT. LTD.

MANUFACTURERS OF
LPG VAPORIZERS



COMPANY PROFILE

Established in 1993 as a specialized unit for manufacturing critical equipment for hydrocarbon industry, OGPE is built on the principles of safety, quality, reliability, ease of operation, energy conservation and 'installation & maintenance'.

With long and rich experience in the field, we have succeeded in designing novel vaporizer models for LPG/Propane/Ammonia service in electrical and steam heating designs besides our flagship hybrid design. We offer energy efficient, reliable and maintenance free vaporizers, which compete with best global designs.

We are also in the business of manufacturing complete pressure reduction stations and metering skids for natural gas service, LOT systems, sliding vane positive displacement pumps and air/water cooled non-lubricated compressor assemblies for transfer of liquid and gas products with main Equipment sourced from our principals Blackmer, USA. These products are used in variety of industries including LPG, chemical processing, refined fuels, petroleum, food & sanitary and the mobile transport industries. We also offer gas leak detection systems for a very wide range of flammable and toxic gases, in association with New Cosmos Electric Co. Ltd, Japan in both portable as well as fixed type designs.

We have supplied these Equipment to very prestigious companies in the private and public sector in India as well as in the overseas markets across Middle East and Africa. Our Clients vouch for the quality of our products, work ethics and our efficient post sales services.

SALIENT FEATURES OF LPG VAPORIZERS

- Properly formed stainless steel coil on coiling machine.
- External liquid trap
- Flame and Explosion proof solenoid valve on liquid inlet.
- Flame and Explosion proof pressure switch on vapour outlet.
- Thermostats for automatic operation
- Safety valve on vapour outlet
- Pressure gauge
- On board Flame & Explosion proof control panel complete with cabling
- Insulated body for energy conservation.
- Water level indicator
- Packaged unit – ready to install
- Safe and reliable
- Low operational and maintenance cost

OPTIONAL FEATURES

- RTD/Digital temperature controller
- High level switch on vapour outlet
- Automatic water level controller
- Hybrid operation with steam coil.

APPROVALS

- Approval No.PV(M) - 528 from Explosives Department, Nagpur

LPG VAPORIZERS

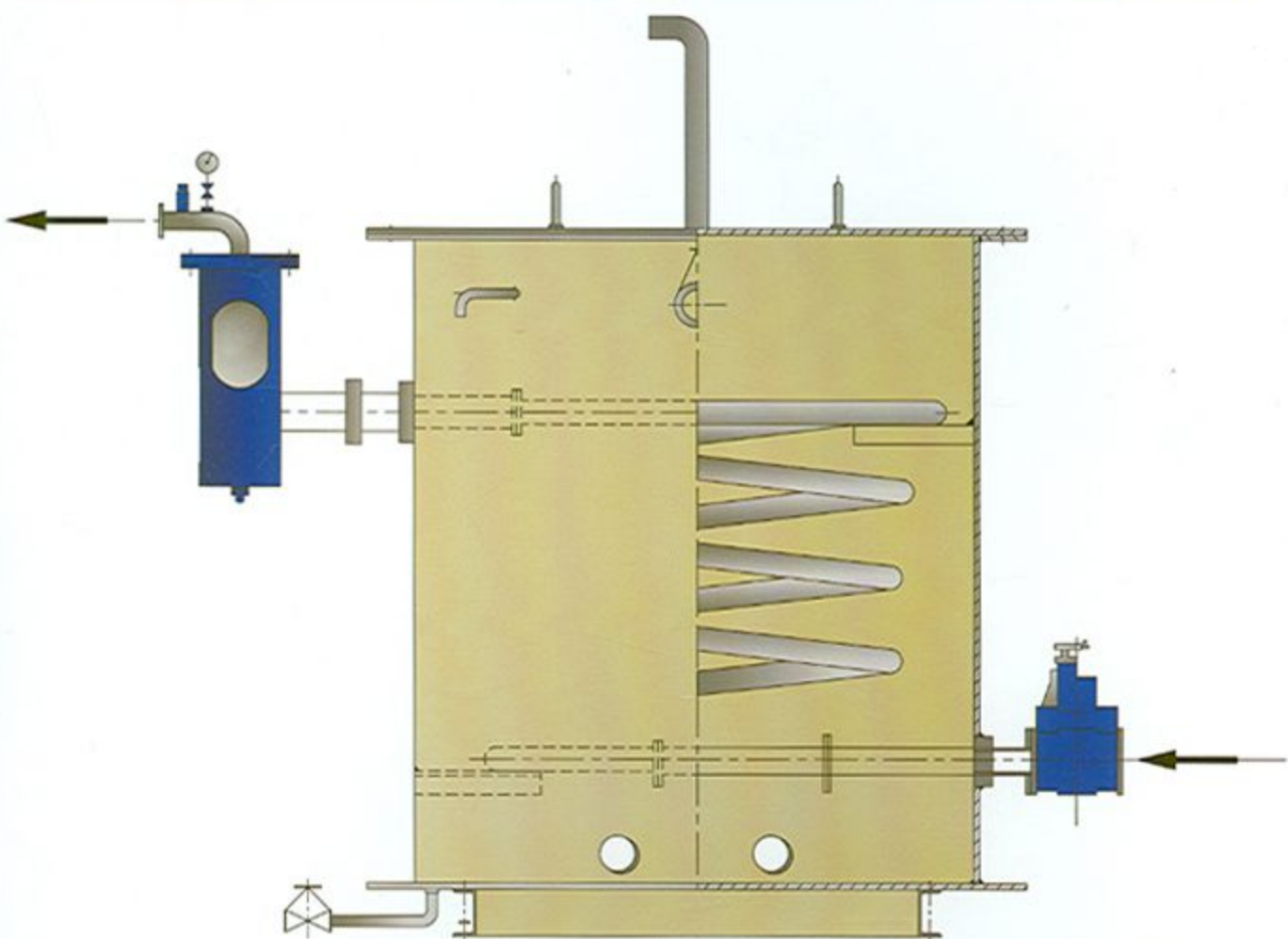

ELECTRICAL/STEAM HEATED WATERBATH DESIGN

MODEL OGPE-P-E

CAPACITY : 25Kgs/HR TO 1000 kgs/hr

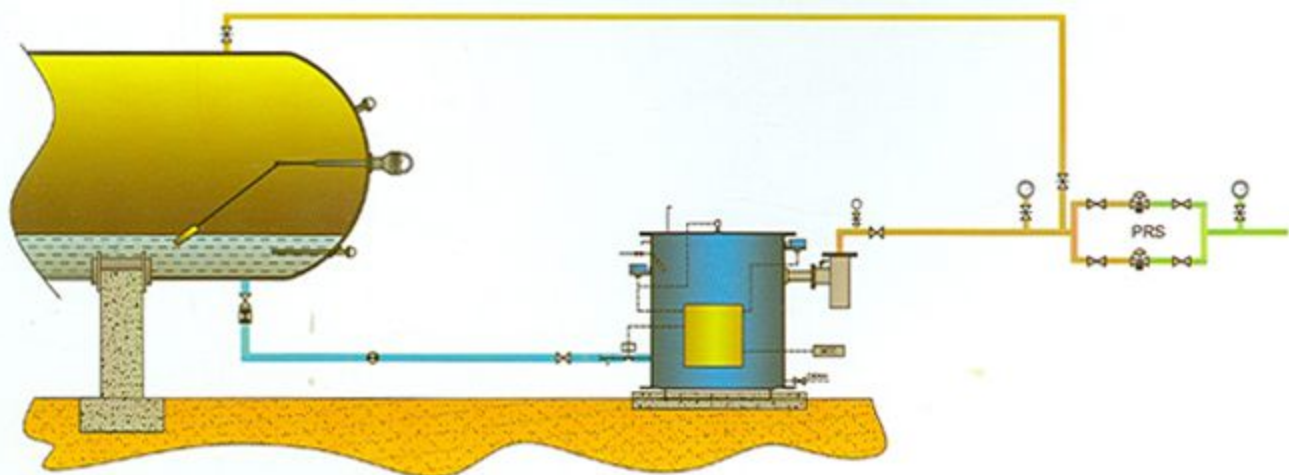

TYPICAL VAPORIZER INSTALLATION

OTHER PRODUCTS

COMPRESSOR PACKAGES



PUMP PACKAGES



PRESSURE REDUCTION & METERING STATIONS



GAS LEAK DETECTION SYSTEMS



LOT SYSTEMS

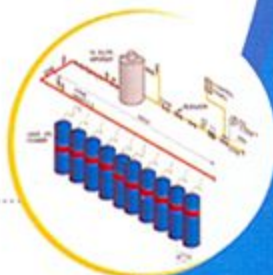

LPG LOADING ARMS

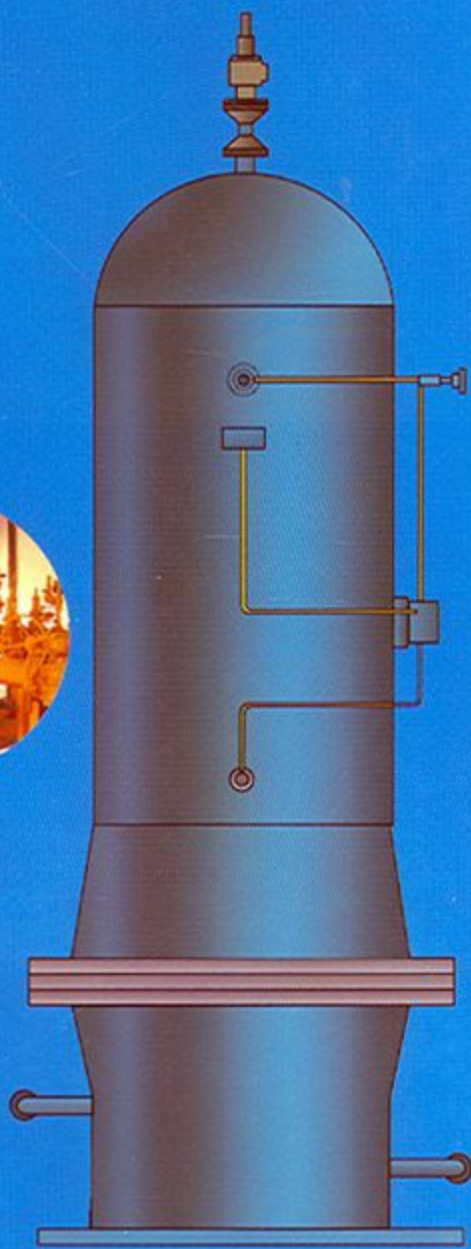

SHELL AND TUBE TYPE VAPORIZER
STEAM/HOT WATER HEATED
MODEL OGPE-S
CAPACITY : 500 Kgs/HR TO 10,000 kgs/hr



MANUFACTURING PLANT:
OIL & GAS PLANT ENGINEERS (I) PVT. LTD.
Shed No.4, 14/3, Mathura Road
Faridabad - 121003 (Haryana) India
PH: 0129-4040818
Fax: 0129 4040818
E-mail: ogpe@ogpeindia.com

WESTERN REGION:
1011 Akik Complex, Opposite Rajpath Club,
S.G. Highway, Bodakdev, Ahmedabad- 380054
Phone: 09998118831
Fax: (079) 40040485
E-mail: anand@ogpeindia.com
MUMBAI:
Mobile: 09466600356
E-mail: salesmum@ogpeindia.com

SOUTHERN REGION:
CHENNAI:
Mobile: 09094844480, 08056204700
E-mail: vijay@ogpeindia.com
HYDERABAD:
Mobile: 09959800011
E-mail: saleshyd@ogpeindia.com
Mobile: 09466600368
E-mail: salessr@ogpeindia.com