

Code ST04	Project A25-B	Release F	Title TECHNICAL DATASHEET
---------------------	-------------------------	---------------------	-------------------------------------

MAGNETIC TRANSDUCER MTS M

GENERAL FEATURES

- Small overall dimensions of the TRANSDUCER.
- MAGNETIC BAND MP200 (or MP200Z with positioned reference signals upon request) is composed of a magnetic strip, which is polarized at regular distances of 2+2 mm and supported by a stainless steel tape. Extremely easy to mount on the operating machine.

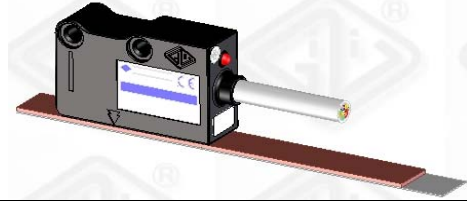

MECHANICAL AND ELECTRICAL FEATURES

MECHANICAL <ul style="list-style-type: none"> • Die-cast transducer. • Double fixing system transducer with M4 screw thread or with M3 through screws. • Liberal mounting tolerances. • Reference signals at required positions (only with MP200Z). 			Code MTS M																																		
			Reference signal constant pitch every 2 mm*** (C) external (E) positioned on magnetic band (Z)																																		
ELECTRICAL <ul style="list-style-type: none"> • Very flexible power cable. • High stability of the signals. • For applications where max. speed exceeds 1m/s, the use of a "special cable" is requested. 			Pole pitch 2+2 mm																																		
			Resolution 1000 - 500 - 100 - 50 - 25 - 10 - 5 - 1 μm																																		
CABLE (2 meters standard length)			Accuracy** ± 15 μm																																		
			Repeatability ± 1 increment																																		
<table border="1" style="width: 100%; border-collapse: collapse;"> <tr> <td style="text-align: center;">Minimum bending radius 60 mm</td> <td colspan="2" style="text-align: center;">8 CORES Ø 5.3 mm</td> </tr> <tr> <td style="text-align: center;">CONNECTIONS</td> <td style="text-align: center;">LINE DRIVER</td> <td style="text-align: center;">PUSH-PULL</td> </tr> <tr> <td>GREEN</td> <td style="text-align: center;">A</td> <td style="text-align: center;">A</td> </tr> <tr> <td>ORANGE</td> <td style="text-align: center;">A</td> <td></td> </tr> <tr> <td>WHITE</td> <td style="text-align: center;">B</td> <td style="text-align: center;">B</td> </tr> <tr> <td>SKY BLUE</td> <td style="text-align: center;">B</td> <td></td> </tr> <tr> <td>BROWN</td> <td style="text-align: center;">Z</td> <td style="text-align: center;">Z</td> </tr> <tr> <td>YELLOW</td> <td style="text-align: center;">Z</td> <td></td> </tr> <tr> <td>RED</td> <td style="text-align: center;">V +</td> <td style="text-align: center;">V +</td> </tr> <tr> <td>BLUE</td> <td style="text-align: center;">V -</td> <td style="text-align: center;">V -</td> </tr> <tr> <td>SHIELD</td> <td></td> <td></td> </tr> </table>			Minimum bending radius 60 mm	8 CORES Ø 5.3 mm		CONNECTIONS	LINE DRIVER	PUSH-PULL	GREEN	A	A	ORANGE	A		WHITE	B	B	SKY BLUE	B		BROWN	Z	Z	YELLOW	Z		RED	V +	V +	BLUE	V -	V -	SHIELD			Cable 8 cores	
			Minimum bending radius 60 mm	8 CORES Ø 5.3 mm																																	
CONNECTIONS	LINE DRIVER	PUSH-PULL																																			
GREEN	A	A																																			
ORANGE	A																																				
WHITE	B	B																																			
SKY BLUE	B																																				
BROWN	Z	Z																																			
YELLOW	Z																																				
RED	V +	V +																																			
BLUE	V -	V -																																			
SHIELD																																					
Output signals LINE DRIVER / PUSH-PULL			Max. measuring frequency 300 kHz																																		
			Sensor - magnetic band distance see drawings																																		
Power supply 5 ÷ 28 Vdc ± 5%			Current consump. without load 60 mA _{MAX}																																		
			Current consumption with load 140 mA _{MAX} (with 5 V and Zo = 120 Ω) 115 mA _{MAX} (with 12 V and Zo = 1.2 kΩ) 90 mA _{MAX} (with 28 V and Zo = 1.2 kΩ)																																		
Phase displacement 90° ± 5° electrical			Max. speed 1.2 m/s (MTS M1) / 12 m/s (MTS M10)																																		
			Vibration resistance 300 m/s ² [55 ÷ 2000 Hz]																																		
Shock resistance 1000 m/s ² (11 ms)			Protection class IP 67 DIN 40050/IEC 529																																		
			Operating temperature 0° ÷ 50°C																																		
Storage temperature -20° ÷ 80°C			Relative humidity 100% (not condensed)																																		
			Weight of transducer 40 g																																		
The sensor is normally supplied with a 2 m cable. It is possible to require longer cables, considering the following maximum available length. L _{MAX} =10 m (sensor cable); L _{MAX} =100 m (2 m sensor cable + cable extension*).			Electrical protections inversion of power supply polarity and short-circuits on output port																																		

* Cable extension with power supply conductor section of 0.5 mm².
 ** In order to obtain this accuracy value, it is necessary to respect the alignment tolerance values prescribed by Manufacturer. Better accuracy results can be obtained by reducing the gap between the sensor and the magnetic band.
 *** Except for model 1K (resolution 1000 μm), having constant pitch every 4mm.

ORDERING CODE

MODEL	PITCH	RESOLUTION	ZERO MARKER	POWER SUPPLY	OUTPUT	CABLE	CONNECTION
MTS	M	10	C	528V	L	M02/N	SC
MTS	M = 2+2mm	1 = 1μm 5 = 5μm 10 = 10μm 1K = 1000μm	C = constant pitch E = external Z = selected on magnetic band	528V = 5÷28V	L = LINE DRIVER	M01/N = 1m M02/N = 2m M10/N = 10m	SC = without conn. C3 = C3 C4 = C4

Example ↪ **MAGNETIC SENSOR MTS M10C 528VL M02/N SC**

Code	Project	Release	Title
ST04	A25-B	F	TECHNICAL DATASHEET

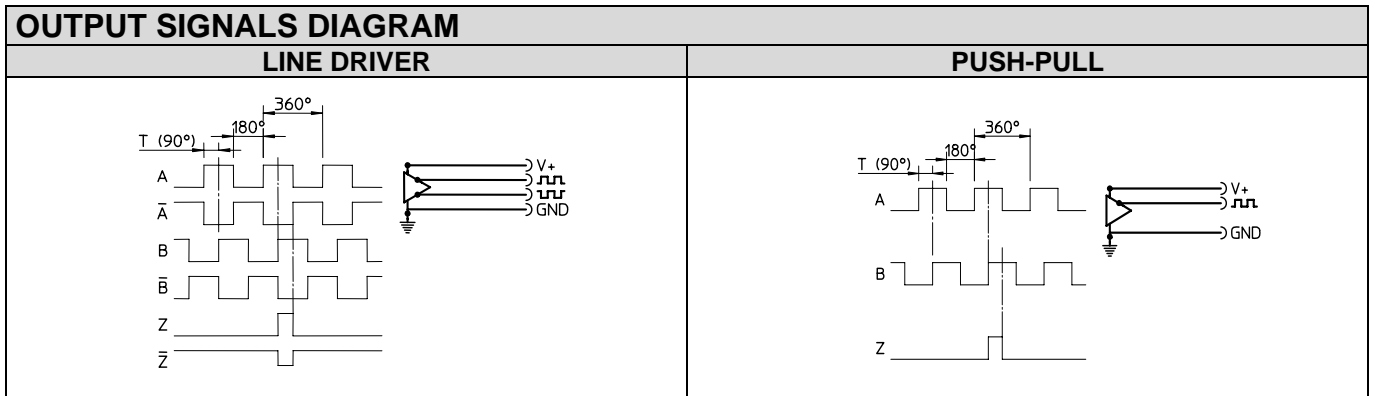

SENSOR DIMENSIONS

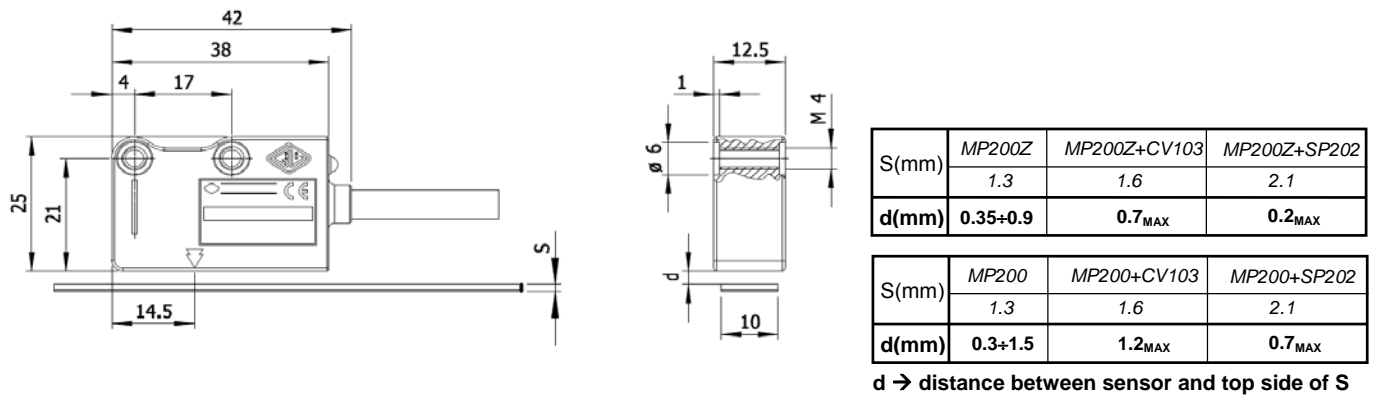

ALIGNMENT TOLERANCES SENSOR-STRIP

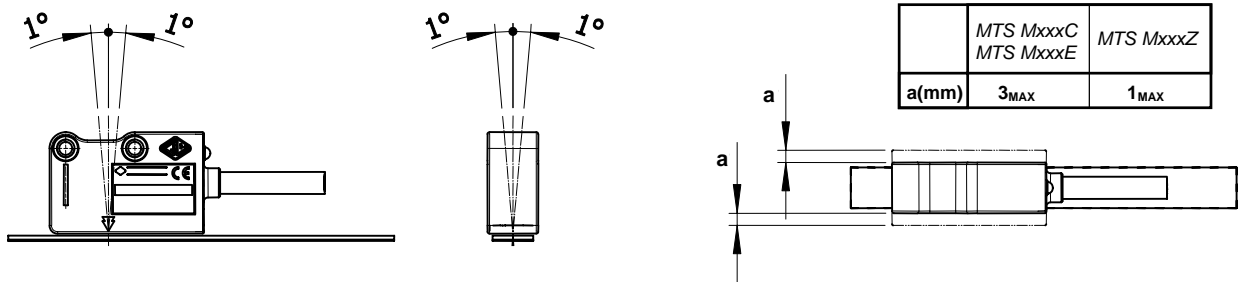

INSTALLATION AND HANDLING

<p>RECOMMENDED MAGNETIC BAND FIXING</p> <ol style="list-style-type: none"> Remove grease from the surfaces by using alcohol and give a finishing touch by using a dry cloth. Fix the magnetic band. Fix the cover strip. <p>After 48 hours the best adhesion will be obtained.</p>		<p>WHAT TO AVOID</p> <ol style="list-style-type: none"> All mechanical reworks (cutting, drilling, face milling etc.). All modifications of the body of slider. All mishandling. Impacts and external stress. Exposure to external magnetic fields. 	
--	--	---	--