

**furnace**<sup>®</sup>  
Science & Technical Furniture

**Go Lean.  
Gain Efficiency.  
Make Profits.**

**with Furnace's Workspace  
Furniture Systems.**

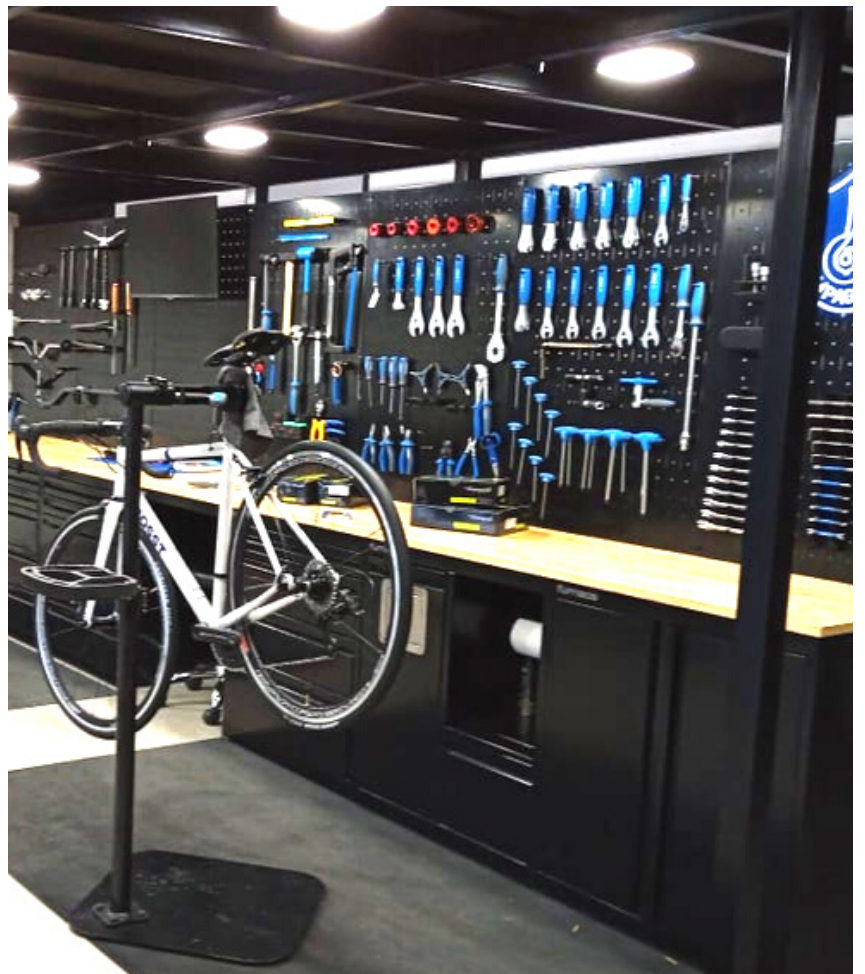

## ABOUT FURNACE

Our solutions help companies enhance their lean management practices while integrating the principles of an ergonomic design to create a balanced work environment.

Furnace offers a complete range of metal based workspace furniture systems.

It consists of workbenches, workstands, cabinets, trolleys, carts, flow racks.





## CONTENTS

Why Furnace	01
Our Value Chain	03
Making Lean More Human	05
Application	07
Our Approach	09
Product Portfolio	11
Clientele	13

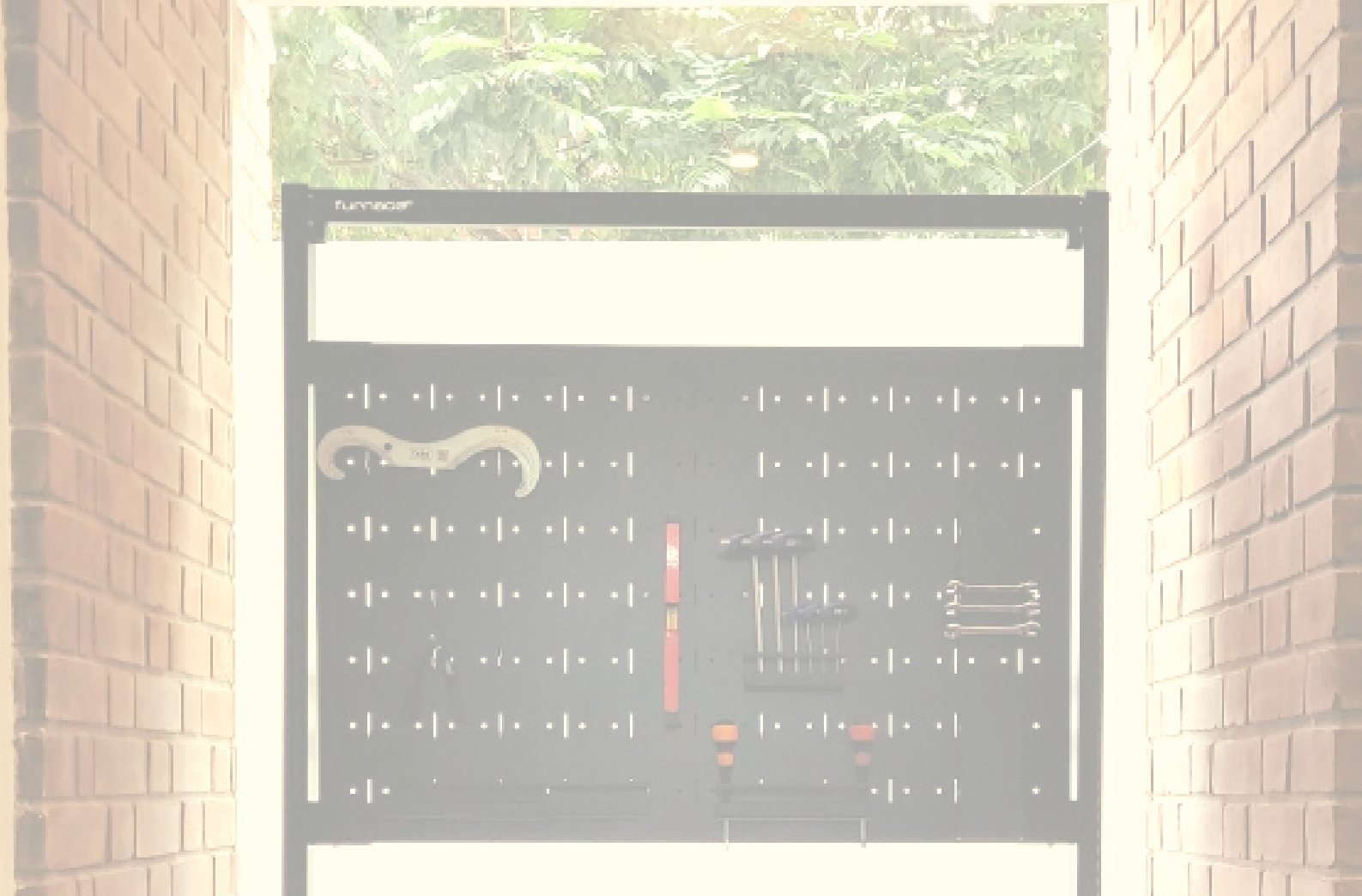

# WHY FURNACE ?



At Furnace, we aim to improve the quality of workspaces which in turn exponentially boosts the efficiency and bottom line of the company. Our systems help you enhance your workspaces dynamics through:



### Comprehensive range

Multiple product options for each case

---

### Space Integrated System

Optimise Space with our integratable products

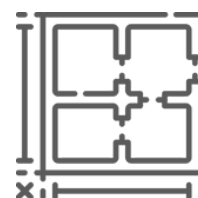

### Custom Play

All products are pre-engineered and modularized for flexibility

---

### Pre - Configured Showcase

Save time and resources to configure Products



### Detailed planning

With 2D and 3D visual documentation

---

### Buying ease

Selection guides, Product Comparisons, Case Studies, Reference Work Gallery



# Our Value chain

## Engineering Design

Value Addition, R&D

---

## Project Management

Individualized attention, time-sensetive

---

## Manufacturing

40+ years experience, Agile methodology

---

## Sales & Marketing

Empathetic approach, Authenticity

---

## Infrastructure:

Furnace is supported by multiple self-owned factories located in over 54,000 sq.ft. in Navi Mumbai. Manufacturing all products in-house provides us with the opportunity to control 100% of the product quality and ability to facilitate projects of all sizes while maintaining competitive pricing and outstanding lead times. All of the factories feature the latest machinery and technology available to use.

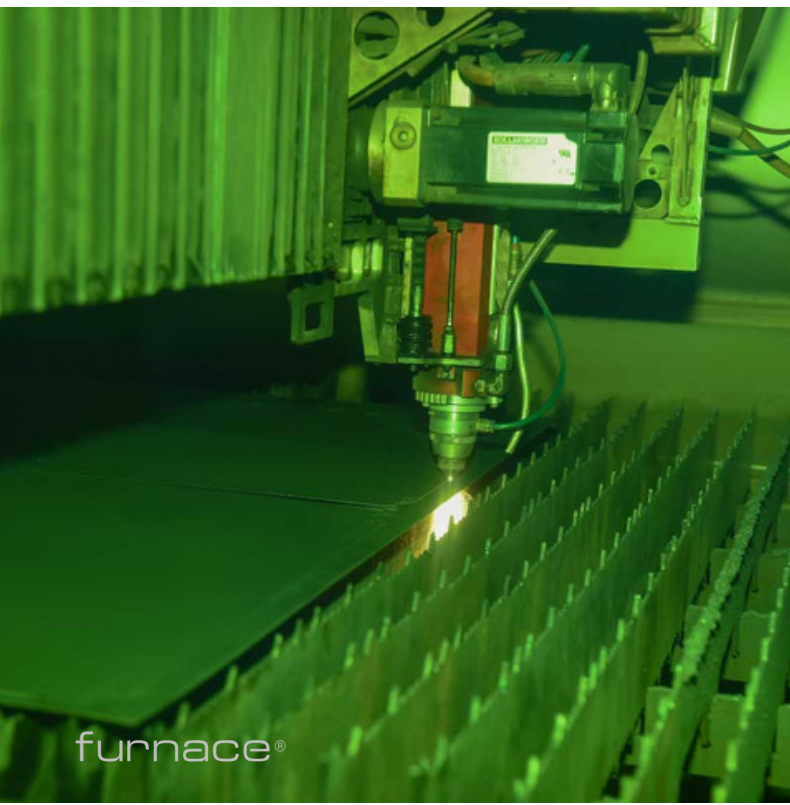

# Making Lean More Human

By working together, these two principles can make the workplace more efficient and safe, eliminating waste and reducing risk for your employees.

## Lean Thinking

Lean is a way of thinking about creating needed value with fewer resources and less waste. It always starts with the customer. What does the customer value? What problem does the customer need to solve?

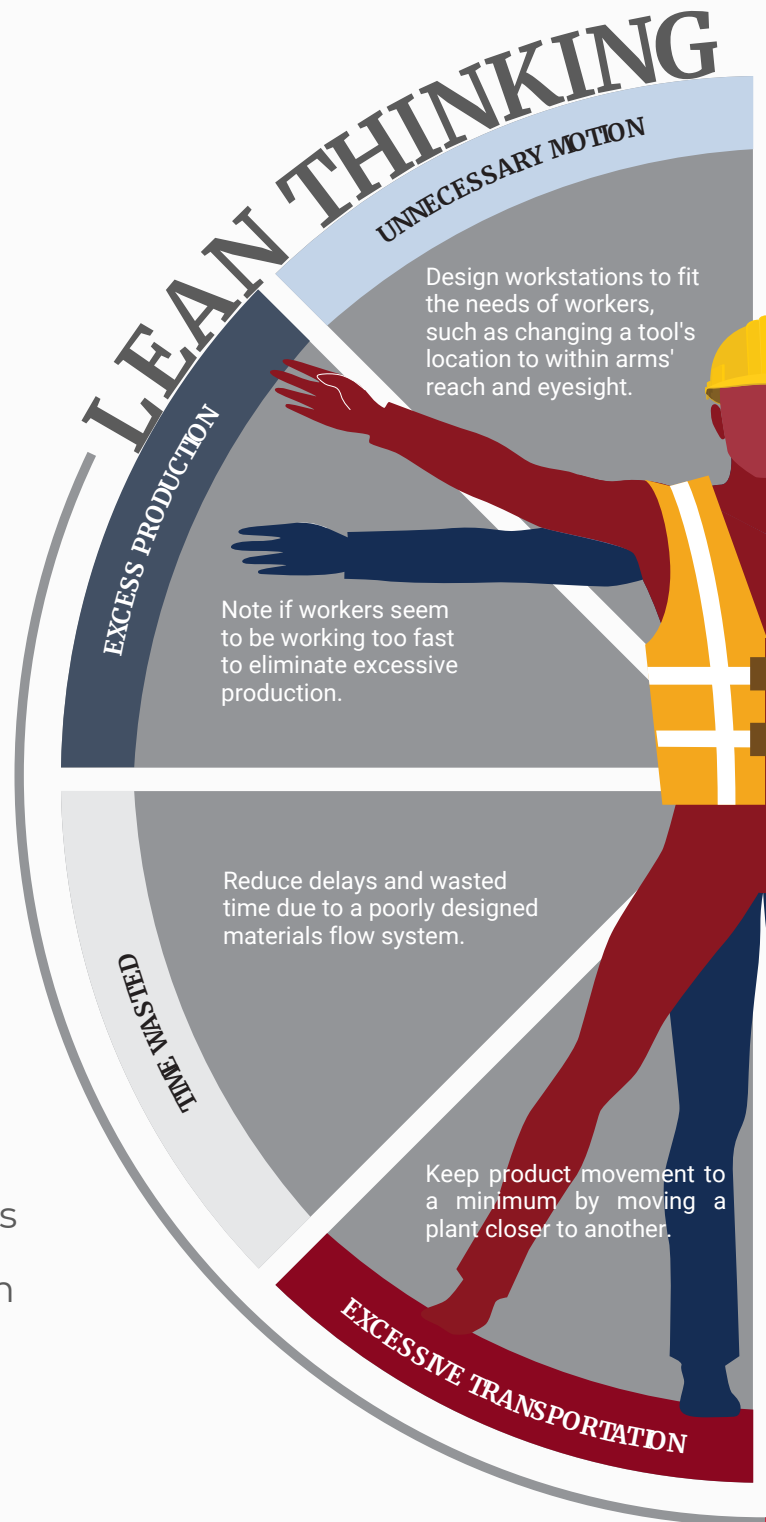



Lean-pushing production efficiencies and ergonomics are two seemingly unrelated fields. However, Lean thinking and Ergonomics go hand in hand-each field impacting the other.

Both can combine to make manufacturing more efficient, profitable, and sustainable.



## Ergonomics

The word ergonomics comes from the Greek word “ergonomic” which means work and “nomos” which means laws. Good ergonomic design removes incompatibilities between work and worker and creates an optimal work environment.

# Application

Furnace system can develop a custom fit, integrated solution to the industries, spaces and application scenarios of every project.

## Assembly Area

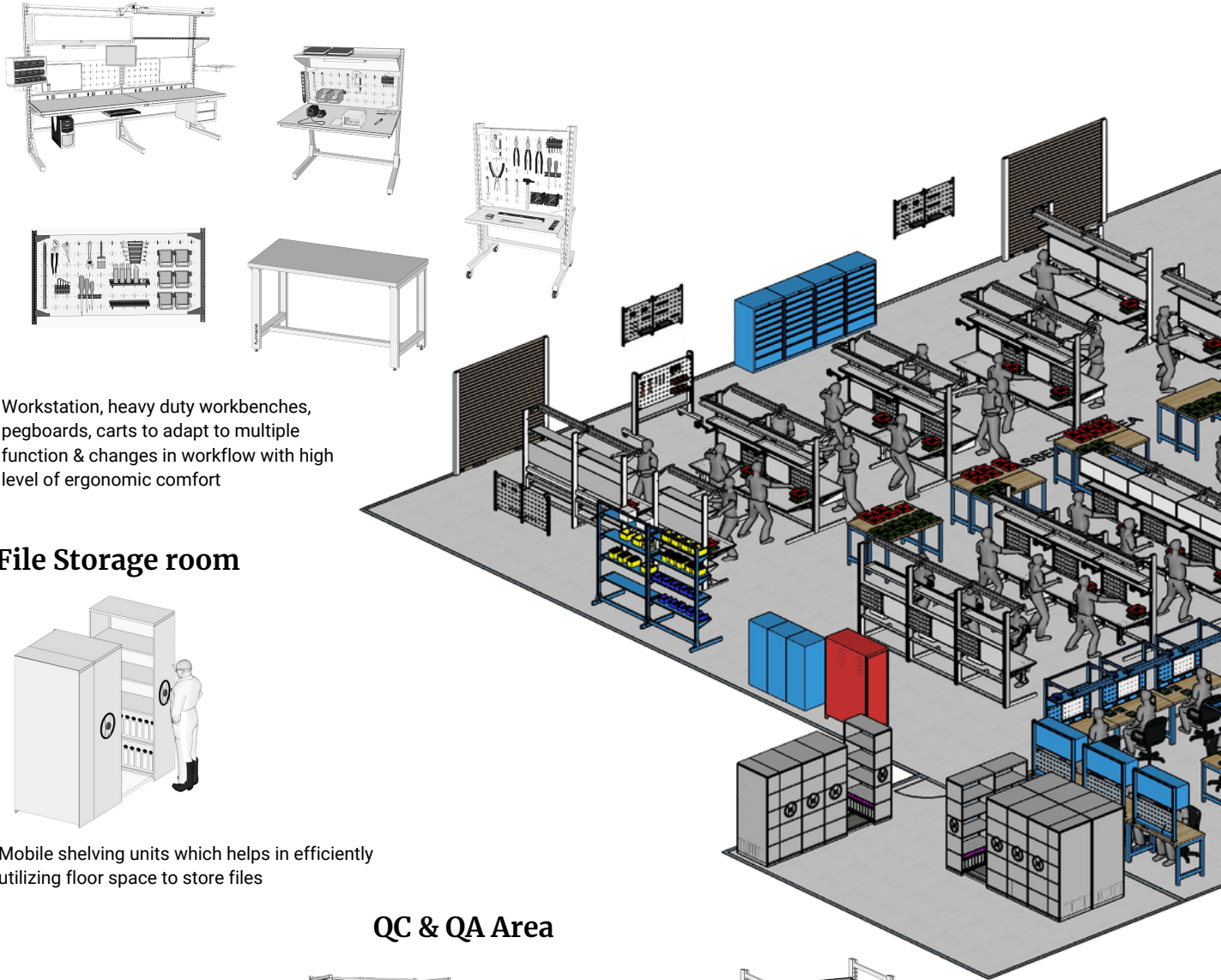

Workstation, heavy duty workbenches, pegboards, carts to adapt to multiple function & changes in workflow with high level of ergonomic comfort

## File Storage room

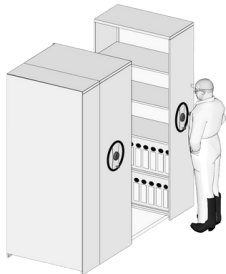

Mobile shelving units which helps in efficiently utilizing floor space to store files

## QC & QA Area

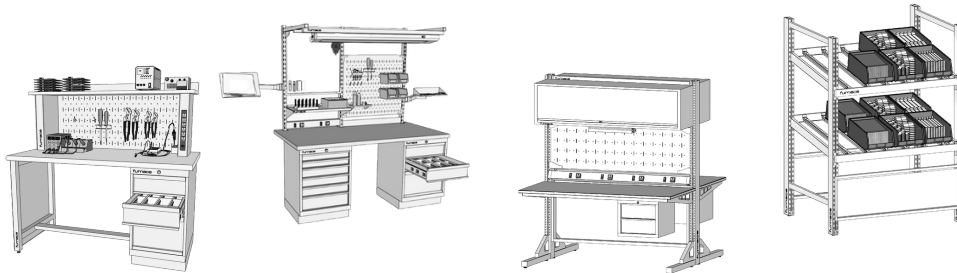

Workbenches with practical work surface materials & accessories to increase efficiency & facilitate sustainability

## Industries

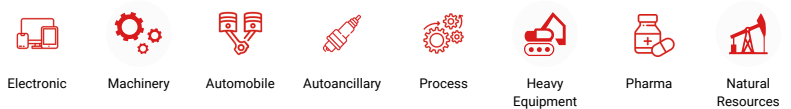

## Packing Area

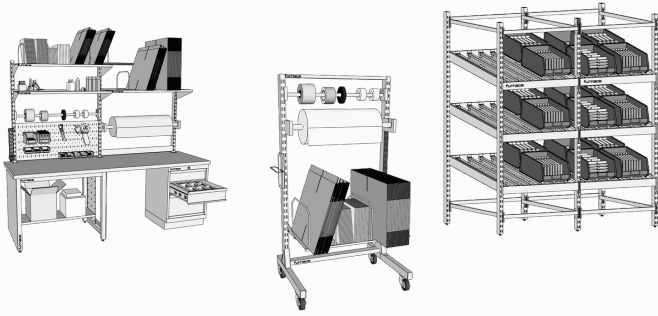

Packaging workstation, Trolleys & flowracks are flexible to accommodate your need for packaging

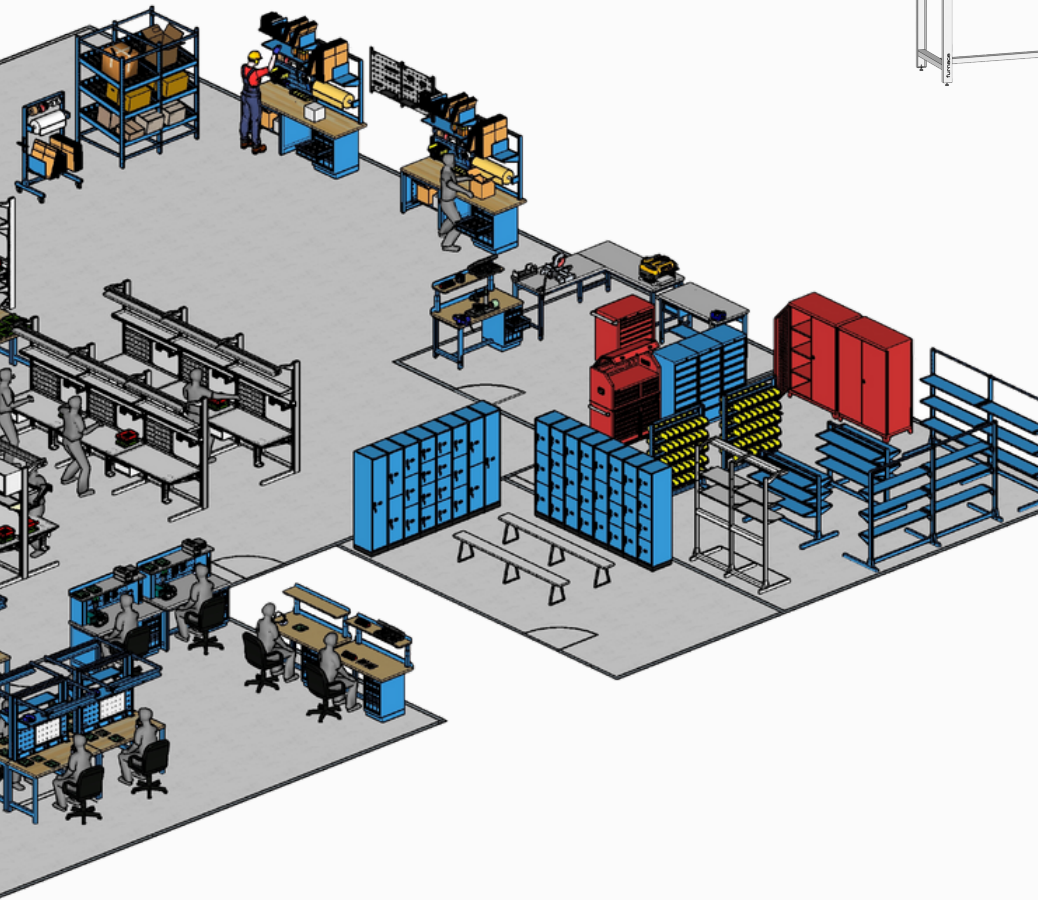

## Maintenance Area



Wide selection of configurable workstations & above worksurface accessories for heavy duty application

## Locker room



Personal & mobile locker with multiple locking options to increase security of personal items

## Store room

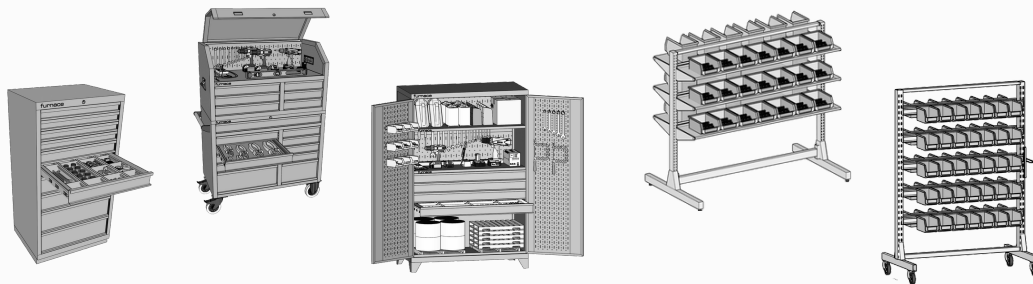

Our wide range of stand, base, mobile & tall cabinet helps to store bulky & small items in one system



Aerospace



Assembly



Gem & Jewellery



Chemical



Packaging



Mining



Agriculture



Utilities

# Our Approach

We strive to add value at every step our buyer's business journey. Being fully aware of the versatile stages that our buyer goes through, our team focuses on empowering its buyers at their pace.



## 1

### Free Consultation



- Talk with our technical experts
- ROI analysis and justification
- Product configuration, project alignment and budget planning



## 2

### Planning Competency



- Techno-commercials delivered within 48 hours\*
- 3D and 2D Product Visuals
- 2D Space Visuals

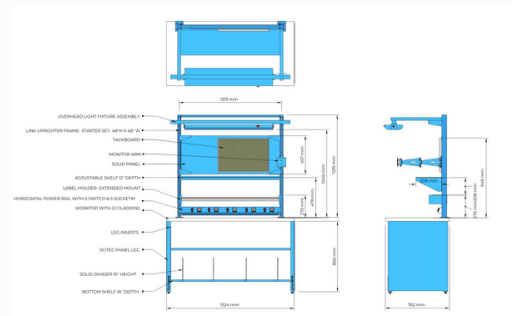
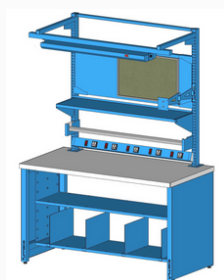
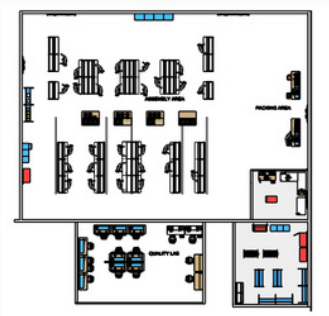

\*Subject to change based on requirements



3

Efficient Delivery



- Manufactured within 4 weeks\*
- Engineered and manufactured in-house



4

Professional Installation



- The Perfect Finish
- Easy to follow assembly instructions
- Self Assembly Friendly



\*Subject to change based on requirements

# Product Portfolio

Furnace offers a diverse range of products designed to bring a perfect balance within space, operation and workers needs.

## Workbenches & Workstations

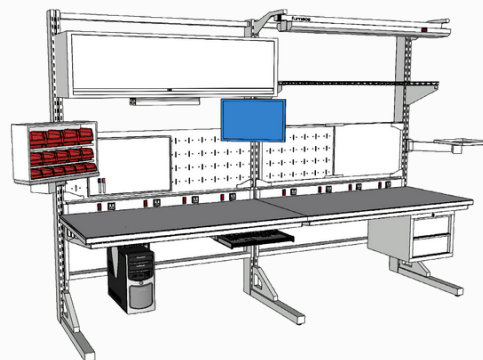
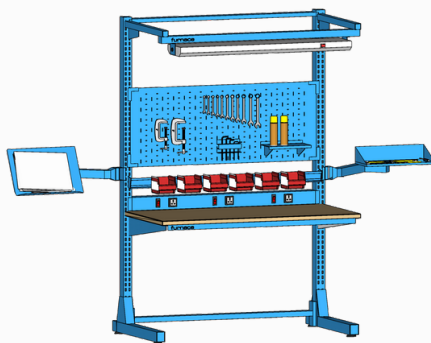
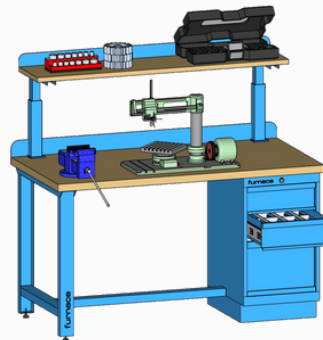
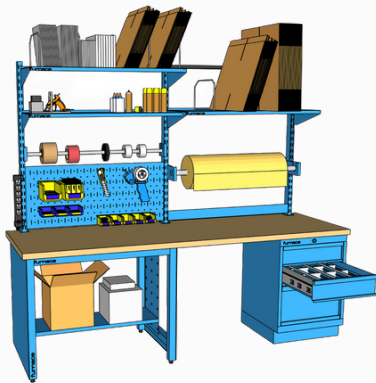
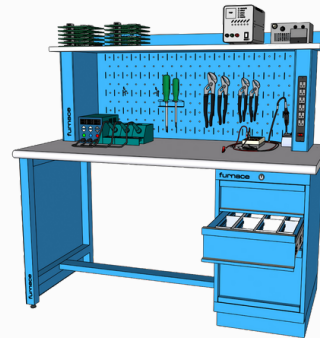
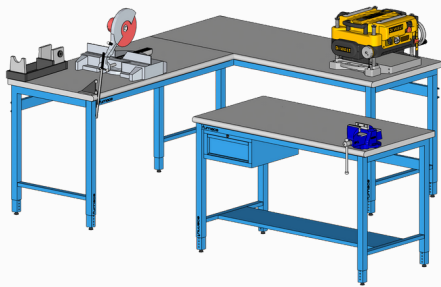

## Trolleys, Carts & Flow Racks



## Cabinets, Pegboard



# CLIENTELE

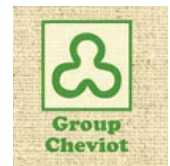

EL-21 TTC Industrial Area, Mahape,  
Navi Mumbai - 400 710  
+ 91 7045763012  
sales@furnaceworkspaces.com

www.furnaceworkspaces.com  
furnaceworkspaces / @

