

Quality
Water Valves

For
Home Appliances

Water Solenoid Valves for Appliances

Features

- ✓ Pilot operated diaphragm water solenoid valves are available in various models and specifications.
- ✓ Available in normally closed, Normally Open and Bistable Latching versions.
- ✓ Water solenoids are available in many standard voltages and option for any specific coil voltage against minimum order.
- ✓ 0.40 mm, removable plastic filter in most models.

Applications

- ✓ Washing machines (for water inlet / feed)
- ✓ Domestic and Industrial water purifiers. (Inlet water control)
- ✓ Dish washers (Water feed / inlet)
- ✓ Feed valve for coffee and hot beverages vending machine.
- ✓ Automatic water taps and faucets.
- ✓ Dental equipments.
- ✓ And other applications where water is need to be controlled by solenoid valve.

[We also manufacture custom designed valves against specific order](#)

Ordering Guide

While ordering please use code as under along with Model code:

Valve type				
Prefix Series : G	Prefix Series : D	Prefix Series : N	Prefix Series : L	Prefix Series : R
Normally Closed Pilot Operated Op. Pressure 0.2 – 8.0 bar	Normally Closed Direct Acting Op. Pressure 1000 (39") mm WC	Normally Closed Pilot Operated Op. Pressure 0.2 – 4.0 bar	Bi Stable, Latching Pilot Operated Op. Pressure 0.2 – 4.0 bar	Normally Closed Direct acting, 2 mm orifice size Op. Pressure 0 – 8.0 bar

3 7 1 1 / A , G I D C , P h a s e - I V , V a t v a , A h m e d a b a d - 3 8 2 4 4 5 , G u j a r a t , I n d i a
Ph.: 91-79-25840845, 40085985 E mail: info@giplindia.com Web Site: http://www.giplindia.com

VALVES FOR DOMESTIC RO SYSTEMS

Models:

Model Code : 1/180 1/4" X 1/4" QC
NO, NC, Low Pressure NC, Bi Stable Latching Operators

Appearance



Dimensions

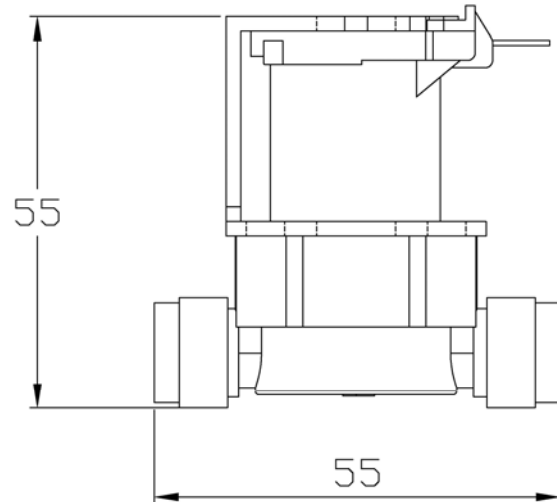

- ✓ **Inlet / Outlet :** 1/4" QC FITTING
- ✓ **Mounting :** Not provided
- ✓ **Food Contact** On request
- ✓ **Flow rate:** 3-8 LPM
- ✓ **Inlet Filter:** Not Provided
- ✓ **Available Valve Type :** Normally Closed (0.2 to 8 bar), Normally Open (0.2 to 4 bar), Low Pressure (1000 mm WC), Magnetically Latching (0.2 to 4 bar)

- ✓ **Available Versions and Voltages :**
- G series :** Normally Closed 6 V DC*, 12, 24, 36, 48 V DC, 110 V*, 230 V AC
- N Series :** Normally Open 12, 24, 36, 48 V DC
- L Series :** Magnetically Latching: 6 – 12 V DC, 60 mS, 9 Ohms.
- D Series :** Low pressure direct acting, 12, 24, 36, 48 V DC, 230 V AC

Mounting Details

N.A.

3 7 1 1 / A , G I D C , P h a s e - I V , V a t v a , A h m e d a b a d - 3 8 2 4 4 5 , G u j a r a t , I n d i a
Ph.: 91-79-25840845, 40085985 E mail: info@giplindia.com Web Site: http://www.giplindia.com

VALVES FOR DOMESTIC RO SYSTEMS

Models:

Model Code : 1/180 1/4" X 1/4" Tube
NO, NC, Low Pressure NC, Bi Stable Latching Operators

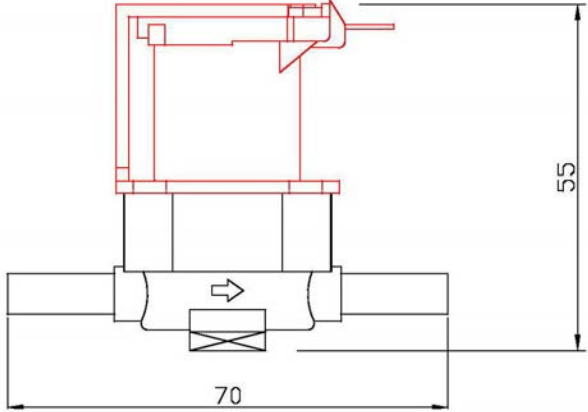
Appearance	Dimensions
	
<ul style="list-style-type: none"> ✓ Inlet / Outlet : 1/4" TUBE FOR QC FITTING ✓ Mounting : Bottom Mounting ✓ Food Contact On request ✓ Flow rate: 3-8 LPM ✓ Inlet Filter: Not Provided ✓ Available Valve Type : Normally Closed (0.2 to 8 bar), Normally Open (0.2 to 4 bar), Low Pressure (1000 mm WC), Magnetically Latching (0.2 to 4 bar) 	<ul style="list-style-type: none"> ✓ Available Versions and Voltages : G series : Normally Closed 6 V DC*, 12, 24, 36, 48 V DC, 110 V*, 230 V AC N Series : Normally Open 12, 24, 36, 48 V DC L Series : Magnetically Latching: 6 – 12 V DC, 60 mS, 9 Ohms. D Series : Low pressure direct acting, 12, 24, 36, 48 V DC, 230 V AC

Mounting Details

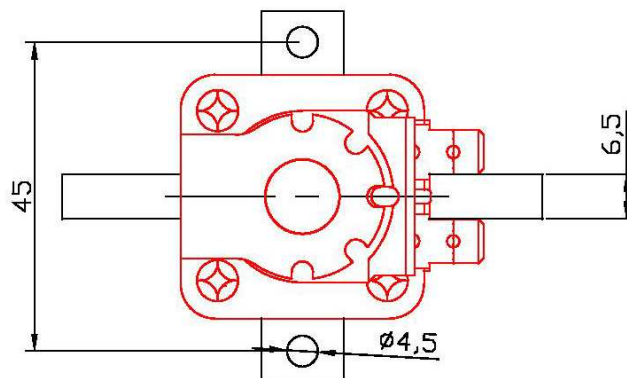

Minimum order of 2000 valves

3 7 1 1 / A , G I D C , P h a s e - I V , V a t v a , A h m e d a b a d - 3 8 2 4 4 5 , G u j a r a t , I n d i a
Ph.: 91-79-25840845, 40085985 E mail: info@giplindia.com Web Site: http://www.giplindia.com

Specifications are subject to change without prior notice due to continuous improvements.

VALVES FOR DOMESTIC RO SYSTEMS

Models:

Model Code : 1/180 1/4" X 1/4" BSPF
NO, NC, Low Pressure NC, Bi Stable Latching Operators

Appearance



Dimensions

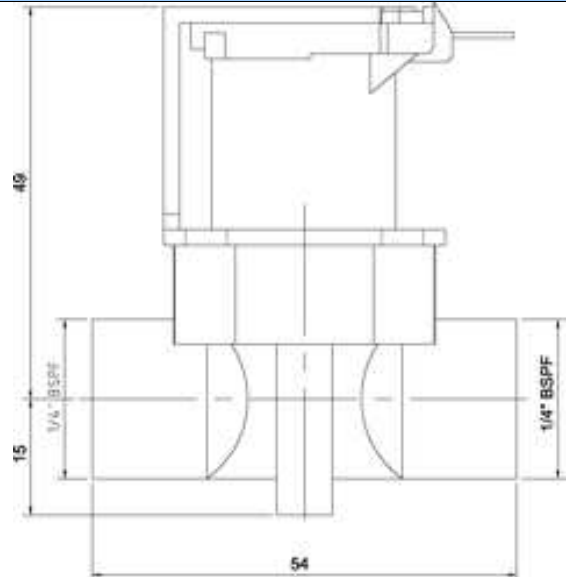

- ✓ **Inlet / Outlet :** 1/4" BSPF
- ✓ **Mounting :** Bottom Mounting
- ✓ **Food Contact** On request
- ✓ **Flow rate:** 6-8 LPM
- ✓ **Inlet Filter:** Not Provided, Optional
- ✓ **Available Valve Type :** Normally Closed (0.2 to 8 bar), Normally Open (0.2 to 4 bar), Low Pressure (1000 mm WC), Magnetically Latching (0.2 to 4 bar)

- ✓ **Available Versions and Voltages :**
- G series :** Normally Closed 6 V DC*, 12, 24, 36, 48 V DC, 110 V*, 230 V AC
- N Series :** Normally Open 12, 24, 36, 48 V DC
- L Series :** Magnetically Latching: 6 – 12 V DC, 60 mS, 9 Ohms.
- D Series :** Low pressure direct acting, 12, 24, 36, 48 V DC, 230 V AC

Mounting Details

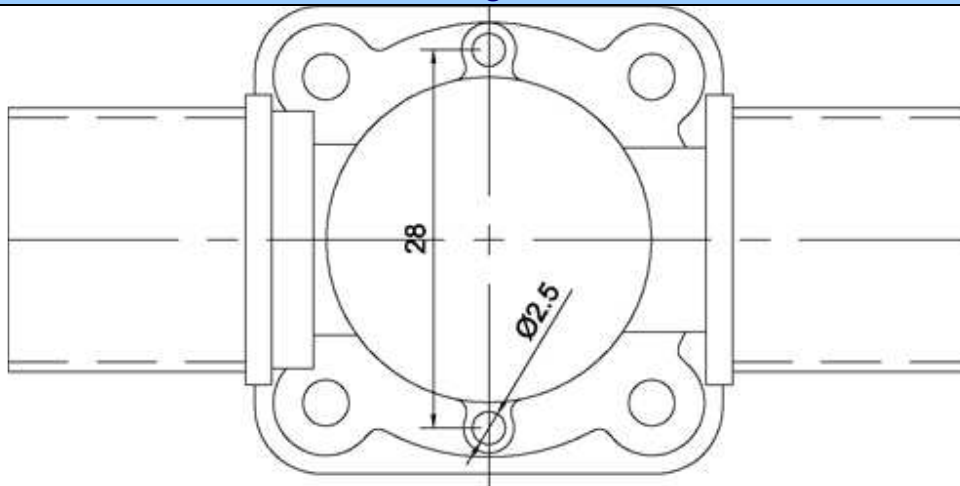

Minimum order of 2000 valves

3 7 1 1 / A , G I D C , P h a s e - I V , V a t v a , A h m e d a b a d - 3 8 2 4 4 5 , G u j a r a t , I n d i a
Ph.: 91-79-25840845, 40085985 E mail: info@giplindia.com Web Site: http://www.giplindia.com

Specifications are subject to change without prior notice due to continuous improvements.

General imsubs

VALVES FOR DOMESTIC & COMMERCIAL RO SYSTEMS, AUTO TAPS, GENERAL ENGINEERING

Models:

Model Code : 1/180 ½"X ½" BSPM

NO, NC, Low Pressure NC, Bi Stable Latching Operators

Appearance



Dimensions

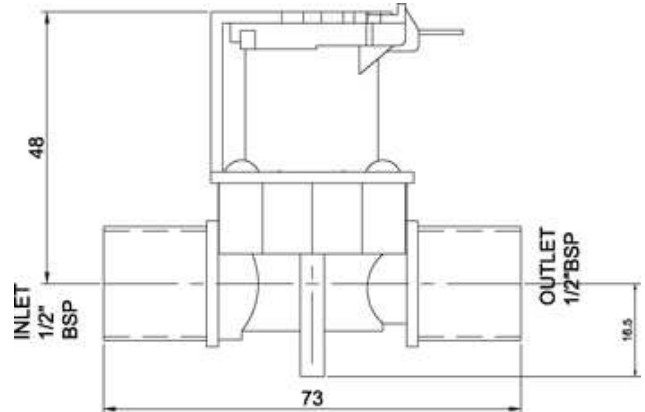

- ✓ **Inlet / Outlet :** ½" BSPM
- ✓ **Mounting :** Bottom Mounting
- ✓ **Food Contact** On request
- ✓ **Flow rate:** 30 LPM
- ✓ **Inlet Filter:** Encapsulated SS mesh, 0.45 mm
- ✓ **Available Valve Type :** Normally Closed (0.2 to 8 bar), Normally Open (0.2 to 4 bar), Low Pressure (1000 mm WC), Magnetically Latching (0.2 to 4 bar)

- ✓ **Available Versions and Voltages :**
- G series :** Normally Closed 6 V DC*, 12, 24, 36, 48 V DC, 110 V*, 230 V AC
- N Series :** Normally Open 12, 24, 36, 48 V DC
- L Series :** Magnetically Latching: 6 – 12 V DC, 60 mS, 9 Ohms.
- D Series :** Low pressure direct acting, 12, 24, 36, 48 V DC, 230 V AC

Mounting Details

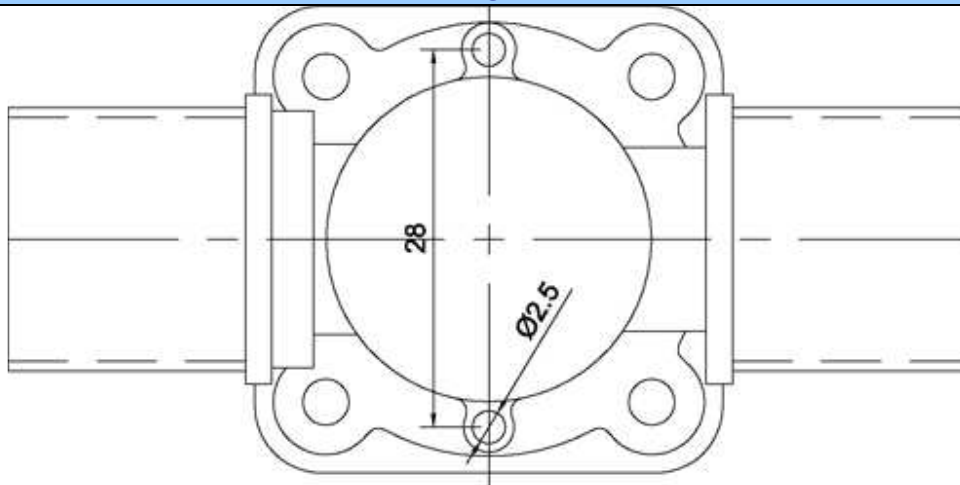

Minimum order of 2000 valves

3711/A, GIDC, Phase-IV, Vatva, Ahmedabad-382 445, Gujarat, India
Ph.: 91-79-25840845, 40085985 E mail: info@giplindia.com Web Site: http://www.giplindia.com

Specifications are subject to change without prior notice due to continuous improvements.

General imsubs

VALVES FOR ICE MAKER, DISH WASHER, WASHING MACHINE, DENTAL EQUIPMENTS

Models:

**Model Code : 1/90, 3 different types of outlet
NO, NC, Low Pressure NC, Bi Stable Latching Operators**

Appearance



Dimensions

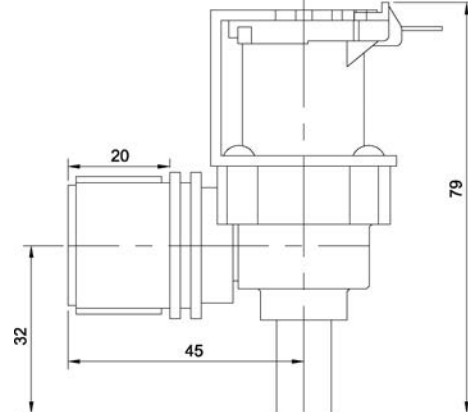

- ✓ **Outlet :** 10.5 mm, 12.5 mm, 1/4" BSPM
- ✓ **Inlet :** 3/4" BSPM
- ✓ **Mounting :** Mounting Bracket (Optional)
- ✓ **Food Contact :** On request
- ✓ **Flow rate :** 1.5 / 2.5 / 5 / 10 / 30 LPM
- ✓ **Inlet Filter :** Polyacetal, 0.45 mm
- ✓ **Available Valve Type :** Normally Closed (0.2 to 8 bar), Normally Open (0.2 to 4 bar), Low Pressure (1000 mm WC), Magnetically Latching (0.2 to 4 bar)

- ✓ **Available Versions and Voltages :**
- G series :** Normally Closed 6 V DC*, 12, 24, 36, 48 V DC, 110 V*, 230 V AC
- N Series :** Normally Open 12, 24, 36, 48 V DC
- L Series :** Magnetically Latching: 6 – 12 V DC, 60 mS, 9 Ohms.
- D Series :** Low pressure direct acting, 12, 24, 36, 48 V DC, 230 V AC

Mounting Bracket (Optional)

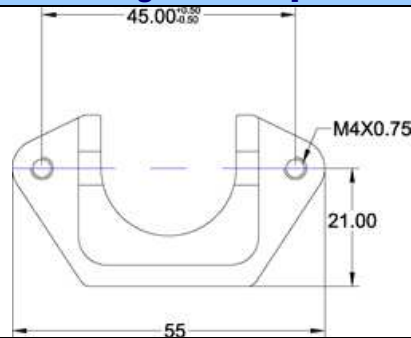

Outlet Options dimension details

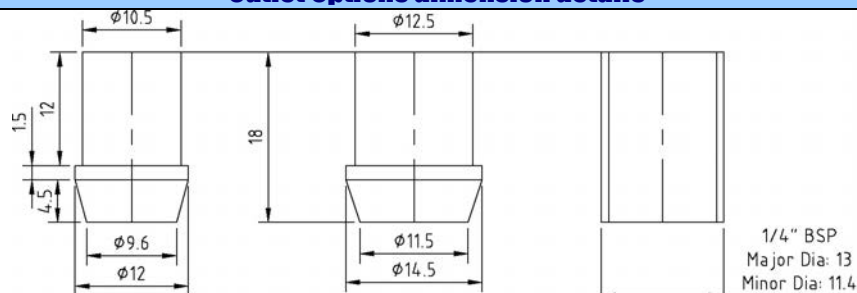

Minimum order of 2000 valves

**3711/A, GIDC, Phase-IV, Vatva, Ahmedabad-382 445, Gujarat, India
Ph.: 91-79-25840845, 40085985 E mail: info@giplindia.com Web Site: http://www.giplindia.com**

Specifications are subject to change without prior notice due to continuous improvements.

General imsubs

VALVES FOR ICE MAKER, DISH WASHER, WASHING MACHINE, DENTAL EQUIPMENTS

Models:

**Model Code : 1/180, 3 different types of outlet
NO, NC, Low Pressure NC, Bi Stable Latching Operators**

Appearance



Dimensions

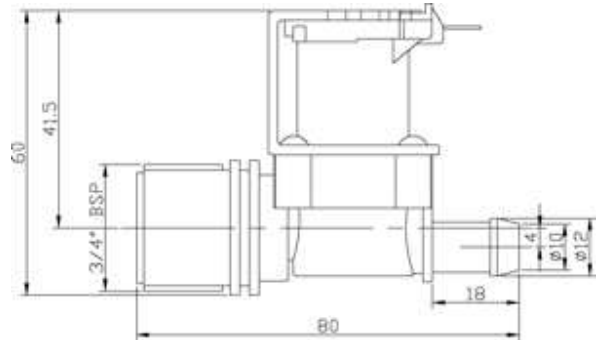

- ✓ **Outlet :** 10.5 mm, 12.5 mm, 1/4" BSPM
- ✓ **Inlet :** 3/4" BSPM
- ✓ **Mounting :** Mounting Bracket (Optional)
- ✓ **Food Contact** On request
- ✓ **Flow rate:** 1.5 / 2.5 / 5 / 10 / 30 LPM
- ✓ **Inlet Filter:** Polyacetal, 0.45 mm
- ✓ **Available Valve Type :** Normally Closed (0.2 to 8 bar), Normally Open (0.2 to 4 bar), Low Pressure (1000 mm WC), Magnetically Latching (0.2 to 4 bar)

- ✓ **Available Versions and Voltages :**
- G series :** Normally Closed 6 V DC*, 12, 24, 36, 48 V DC, 110 V*, 230 V AC
- N Series :** Normally Open 12, 24, 36, 48 V DC
- L Series :** Magnetically Latching: 6 – 12 V DC, 60 mS, 9 Ohms.
- D Series :** Low pressure direct acting, 12, 24, 36, 48 V DC, 230 V AC

Mounting Bracket (Optional)

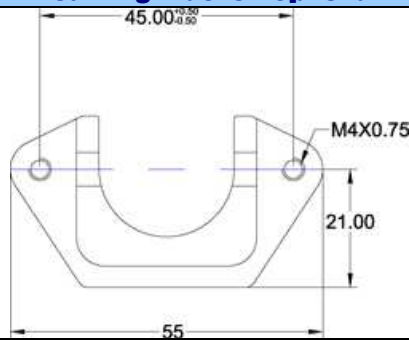

Outlet Options dimension details

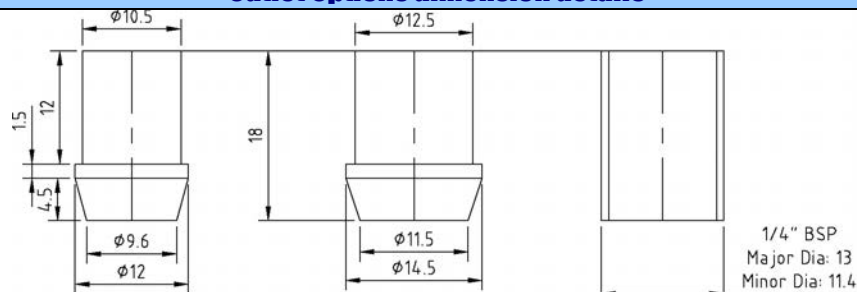

Minimum order of 2000 valves

**3 7 1 1 / A , G I D C , Phase-IV, Vatva, Ahmedabad-382 445, Gujarat, India
Ph.: 91-79-25840845, 40085985 E mail: info@giplindia.com Web Site: http://www.giplindia.com**

Specifications are subject to change without prior notice due to continuous improvements.

General imsubs

VALVES FOR ICE MAKER, DISH WASHER, WASHING MACHINE, DENTAL EQUIPMENTS

Models:

Model Code : 1/90BB

NO, NC, Low Pressure NC, Bi Stable Latching Operators

Appearance



Dimensions

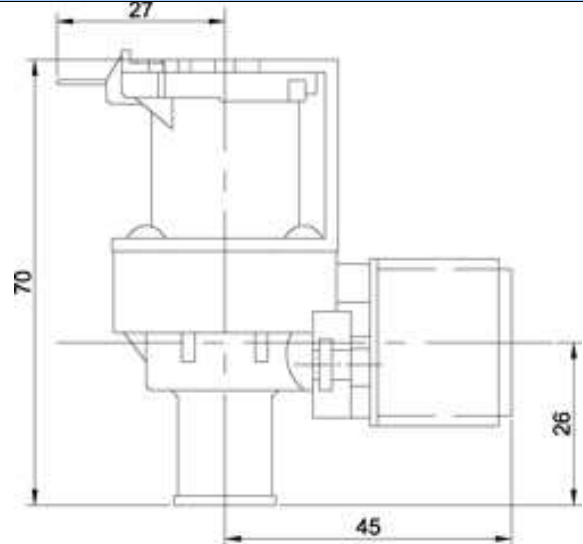

- ✓ **Outlet** : 14 mm Hose Barb
- ✓ **Inlet** : 3/4" BSPM
- ✓ **Mounting** : Mounting Bracket - Built in
- ✓ **Food Contact** On request
- ✓ **Flow rate**: 5 / 10 / 30 LPM
- ✓ **Inlet Filter**: Polyacetal, 0.45 mm
- ✓ **Available Valve Type** : Normally Closed (0.2 to 8 bar), Normally Open (0.2 to 4 bar), Low Pressure (1000 mm WC), Magnetically Latching (0.2 to 4 bar)

- ✓ **Available Versions and Voltages** :
 - G series** : Normally Closed 6 V DC*, 12, 24, 36, 48 V DC, 110 V*, 230 V AC
 - N Series** : Normally Open 12, 24, 36, 48 V DC
 - L Series** :Magnetically Latching: 6 – 12 V DC, 60 mS, 9 Ohms.
 - D Series** : Low pressure direct acting, 12, 24, 36, 48 V DC, 230 V AC

Mounting Bracket (Built In)

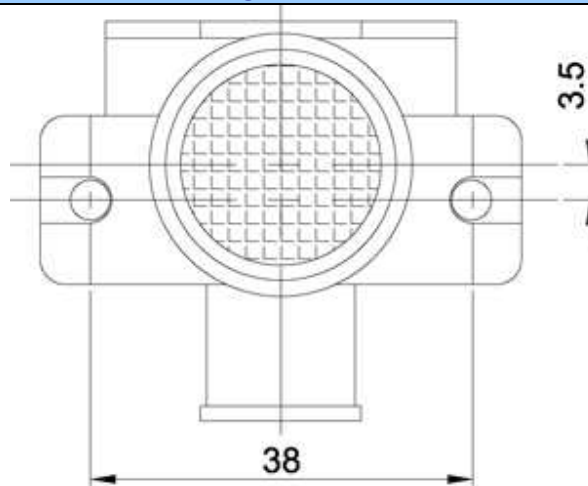

Minimum order of 2000 valves

3711/A, GIDC, Phase-IV, Vatva, Ahmedabad-382 445, Gujarat, India
Ph.: 91-79-25840845, 40085985 E mail: info@giplindia.com Web Site: http://www.giplindia.com

Specifications are subject to change without prior notice due to continuous improvements.

Technical Specifications:

Sr.No.	PARAMETER	DESCRIPTION
1.	Type	Normally Closed : Pilot operated diaphragm type. Normally Open : Pilot operated diaphragm type. Low Pressure : Direct Acting Latching : Pilot operated diaphragm type
2.	Connector	Normally Closed : Horizontal Spade, 6.3 x 0.8 mm (Faston Tags) Normally Open : Horizontal Spade, 6.3 x 0.8 mm (Faston Tags) Low Pressure : Horizontal Spade, 6.3 x 0.8 mm (Faston Tags) Latching : Flexible Wire 100 mm L
3.	Electric Rating	Normally Closed : 6 V DC* / 12 V DC / 24 V AC / 24 V DC / 36 V DC / 48 V DC / 110-120 V AC* / 220-240 V AC (for AC 50 / 60 Hz.) Normally Open : 12 V DC / 24 V DC / 36 V DC / 48 V DC Low Pressure : 12 V DC / 24 V DC / 36 V DC / 48 V DC, 230 V AC Latching : 6 – 12 V DC.
4.	Current	Normally Closed : 6 W Normally Open : 6 W Low Pressure : 8 W Latching : 9 Ohms
5.	Insulation Class	Winding: "F", 155° C. Class-II
6.	Insulation Resistance	Over 500 M Ohms
7.	Insulation Breakdown Voltage	2.5 kV, 1 Sec.
8.	Solenoid Temperature Rise	Under 95° C. at 25° C. ambient.
9.	Suitable Fluid	Water
10.	Ambient Temp.	45° C. max.
11.	Fluid Temp.	60° C max.
12.	Operating Pressure	Please check model pages
13.	Mounting Position	Any (Coil upright preferred)
14.	Life	More than 500,000 cycles.

3 7 1 1 / A , G I D C , P h a s e - I V , V a t v a , A h m e d a b a d - 3 8 2 4 4 5 , G u j a r a t , I n d i a
Ph.: 91-79-25840845, 40085985 E mail: info@giplindia.com Web Site: http://www.giplindia.com

Bill of Material:

Sr.	Part Name	Material	Remark
1.	Body	Nylon, Glass filled	Applicable to all model except G 1/90 BB, Food contact compatible
2.	Body	Polypropylene	Applicable to G 1/90 BB, Food contact compatible
3.	Armature Guide	Nylon, Glass Filled	Applicable to all models, Food contact compatible
4.	Armature	SS 410/430	Food contact compatible
5.	Spring	SS 304	Food contact compatible
6.	Diaphragm	Rubber, Nitrile	Food contact compatible
7.	Pilot	Poly Acetal	Food contact compatible
8.	Inlet Flow restrictor	Nylon / Polyacetal	Not provided in 1/2" and 1/4" BSP valves., Food contact compatible
9.	Inlet flow rubber	Rubber, Nitrile	Not provided in 1/2" and 1/4" BSP valves., Food contact compatible
10.	Outlet Flow restrictor	Poly Acetal	For valve having flow rate less than 5 LPM. Not provided in 1/2" and 1/4" BSP valves., Food contact compatible
11.	Outlet flow rubber	Rubber, Nitrile	For valve having flow rate less than 5 LPM. Not provided in 1/2" and 1/4" BSP valves, Food contact compatible
12.	Filter	Polyacetal	SS filter in 1/2" BSP valve. Not provided in 1/4" BSP valve, Food contact compatible
13.	Spool	Nylon, Glass Filled	Fire retardant construction available.
14.	Coil Encapsulation	Nylon	
15.	Winding wire	Copper enameled wire	Insulation class "F", 155° C
16.	Coil Holding Assembly	Soft Steel	
17.	Lugs	Tin plated Brass	
18.	Screws	Carbon Steel	Applicable to model G 1/90, G 1/90BB, G 1/180

3 7 1 1 / A , G I D C , P h a s e - I V , V a t v a , A h m e d a b a d - 3 8 2 4 4 5 , G u j a r a t , I n d i a
Ph.: 91-79-25840845, 40085985 E mail: info@giplindia.com Web Site: http://www.giplindia.com

Magnetically Latching Solenoid Valves

Models:

All valves model shown in G series is available in latching version. Image shown below is just a representation of difference between normal valve and latching solenoid valve.

See the difference in coil type. In normal valve, coil terminals are spade type tags, where as in latching valve it is wired leads.

Latching valve models are prefixed with **L** instead of **G**.

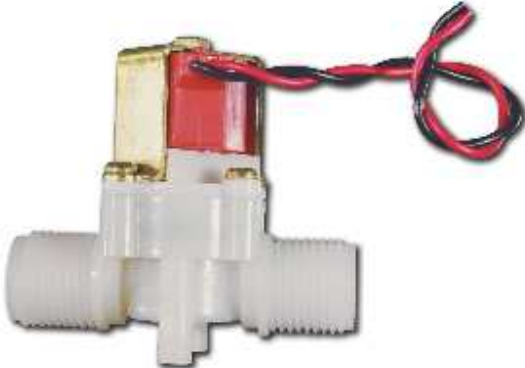
Shown here is L 1/180 ½" X ½"	Available Models
	<ul style="list-style-type: none"> ✓ L 1/90 (3 types of outlets) ✓ L 1/180 (3 types of outlets) ✓ L 1/90 BB ✓ L 1/180 ½" X ½" ✓ L 1/180 ¼" X ¼" ✓ L 1/180 ¾" GHT <p>For dimensions see equivalent G series valve</p>
<ul style="list-style-type: none"> ✓ Inlet / Outlet : ½" BSPM threaded ✓ Mounting: Bottom mounting studs ✓ Food Contact Standard option 	

Features

- ✓ Pilot operated diaphragm type solenoid valves are available in all models of G series valves,
- ✓ Used where power supply has limitations to supply continuous power to keep valve ON.
- ✓ Also places where heat transfer from coil to water is not desirable.
- ✓ Operates from 4.8 V DC to 12 V DC pulse.
- ✓ Maximum pulse width required is 60 mS @ 6 VDC, 6 bar pressure.
- ✓ Food contact compatible construction available.
- ✓ 0.40 mm, removable plastic filter.

Applications

- ✓ Automatic sensor taps and faucets.
- ✓ Automatic sensor urine flushing system.

3 7 1 1 / A , G I D C , P h a s e - I V , V a t v a , A h m e d a b a d - 3 8 2 4 4 5 , G u j a r a t , I n d i a
Ph.: 91-79-25840845, 40085985 E mail: info@giplindia.com Web Site: http://www.giplindia.com

✓ Battery operated control systems.

Technical Specifications Magnetically Latching Solenoid:

Sr.No.	PARAMETER	DESCRIPTION
1.	Type	Pilot operated diaphragm type.
2.	Configuration Type	2/2 magnetically latching, Bi stable
3.	Connector	Wired leads, 100 mm L, Red and Black color.
4.	Resistance of Coil	10 +/- 1 Ω
5.	Operating Range of voltage	4.8-12 V DC
6.	Pulse width @ 6 bar	ON 20 \pm 2 mS @ 4.5 \pm 5% V DC 27 \pm 2 mS @ 4 \pm 5% V DC OFF Less than 12 mS @ 4 \pm 5% V DC
7.	Insulation Class	Winding: "F", 155° C. Class-II
8.	Fluid Temp.	60° C max.
9.	Operating Pressure	0.2 bar to 6 bar
10.	Mounting Position	Any (Coil upright preferred)
11.	Burst Pressure	16 bar minimum.
12.	Water Leakage	No leakage from 0.2 bar to 6 bar.
13.	Mechanical Life	More than 500,000 cycles.

3 7 1 1 / A , G I D C , P h a s e - I V , V a t v a , A h m e d a b a d - 3 8 2 4 4 5 , G u j a r a t , I n d i a
Ph.: 91-79-25840845, 40085985 E mail: info@giplindia.com Web Site: <http://www.giplindia.com>

Latching Valve operation schematic diagram

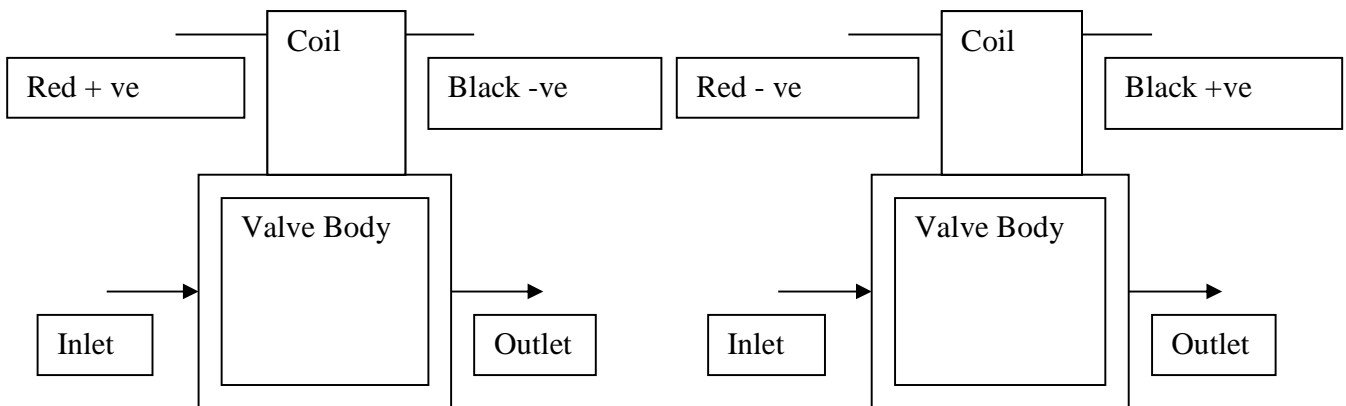

Position 1, if valve is in closed condition and coil is supplied voltage pulsed current having pulse width of 60 mS, than valve comes in open position and remains open till supplied current as shown in position 2

Position 2, when valve is opened by supplying current as mention in position 1, it can be closed only by supplying current as mentioned above. Valve remain in off position till power is supplied as mentioned in position 1.

Brief Design Guide:

- ✓ Life of battery (1.5 V DC X 4 Nos. alkaline) is about 250 000 cycles (only valve operations).
- ✓ Latching valve operates upto 5 V DC, 60 mS pulse. Hence circuit should have cut off voltage or battery low / replace battery indication suitably.
- ✓ It is preferred to mount latching valve in coil up right position.
- ✓ As supply voltage goes higher pulse width decreases.
- ✓ 40 mS pulse is optimum pulse width for valve operation from CLOSE to OPEN position. For OPEN to CLOSE position, pulse width of 20 mS may be kept. This will maximize battery life.
- ✓ Circuit employed in operation of valve should be of high quality and should have minimum current consumption in stand by mode to maximise battery life.
- ✓ Test figures mentioned in this document is based on 6 V DC obtained using 1.5 V X 4 Nos. alkaline batteries.

About Us :

General Imsubs is pioneer manufacturer of water valves in India since 1992. We have been manufacturing wide range of water valves catering to the need of growing appliances industry.

Valve manufactured by General Imsubs complies to stringent international product standards like UL, CE, EN, VDE and JIS.

All valves supplied by General Imsubs are warranted for performance and we offer warranty to all OE customers. Our sophisticated manufacturing and tracking systems can track valves upto its component and raw material level. All valves are custom labeled with customer name to ease tracking even at customer end.

Our manufacturing facilities are equipped with sophisticated CNC coil winding machines, specially designed test rigs to check performance of valves.

All valves goes through 100% tests, as per applicable international standards.