

CRANE CONTROL EQUIPMENTS

SINCE 1988

A vital support of your Cranes



- Established Since 1988
- Complete In-house Testing Facilities
- Approved with various Govt. agencies
- Computer Aided Design.
- Compatible with all other makes.
- AN ISO 9001-2008 Certified Company Since 2009.

An Introduction about us at Crane Control Equipments.

We are a leading **ISO 9001- 2008 CERTIFIED COMPANY** established in the year 1988 manufacturing **Control Gear Equipment**, used in **EOT Cranes** , **Cane Unloaders** as well as **Grabbing Cranes** etc. which includes the following.

STARTING RESISTORS

- **AUTO Matic ROTOR STARTER PANEL**

DYNAMIC BRAKING RESISTORS

- **PUNCHED GRID RESISTANCE BOXES**

MASTER CONTROLLERS

- **S.S.WIRE GRID RESISTANCE BOXES**

LEVER LIMIT SWITCHES

- **ELECTRO HYDRAULIC THRUSTOR BRAKES**

ROTARY LIMIT SWITCHES

- **ELECTRO HYDRAULIC THRUSTORS**

CURRENT COLLECTORS

- **ELECTRO MAGNETIC BRAKES**

CABLE REELING DRUMS

- **FLEXIBLE GEARED COUPLINGS**

CABLE TROLLEYS

- **PENDANT PUSH BUTTON**

We are also manufacturing Starting / Slip Resistors used for starting high capacity Slip ring Motors in industries such as Sugar Mills, Rolling Mills etc. as well as Dynamic Braking Resistors for AC Drives.

Our **USP** has been to provide excellent service to both **Crane manufacturers** as well as users and most of the Crane manufacturers are installing our products as **original equipment**.

Our products are approved in both private as well as Government organisations.

We are in fact also a regular supplier to various Electricity Boards ,Railway Workshops and other government organisations all over India and our material is also being exported out side India.

Our products are designed, based on the respective Indian Standards and hence can be interchanged with other brands provided of course if the other manufacturer has also followed the correct Indian Standards while designing and manufacturing his product. Also in our company we have an on going process of **R&D** for improving the Quality of our products.

Since we are regularly manufacturing the products at times we can even supply material at short notice there by reducing the down time of the **customer's system during maintenance or brake down.**

Supplying equipment at short notice does not mean that the equipment does not under go proper tests.

An in house testing facility and quality control department checks every product as per the relevant standards before it is despatched from our works.

In addition to the complete range of Control Gear Equipment and in keeping with our commitment to provide our customers with the best possible services, We also supply **SHROUDED BUS BAR CONDUCTORS** as well as **RADIO REMOTE CONTROLS & ANTI-COLLISION DEVICE** etc. so that at our factory where we have a single out let, we can provide our customer be it a Crane manufacturer or a Crane user this unique service:

"The availability of complete range of Control Gear Products under one Roof"

ELECTRO HYDRAULIC THRUSTER BRAKES (MDT)

INSTALLING BRAKE IN POSITION :

To insert the brake in position the brake shoes are to be taken apart to clear the drum diameter. To do this, slacken the setting bolts and the tie-rod nuts in the side arm and pull it slightly. This will increase the distance between the brake shoes and the brake can now be inserted on the foundation bolts and the shoes can be positioned on the brake drum. Re-tighten the setting bolt and the tie-rod nuts. Tighten the mounting bolts.

INSTALLING THRUSTER ON BRAKE :

The thruster to be filled with sufficient quantity of oil as mentioned in the Thruster Table. To mount the thruster on the brake, remove one side split pins on the thruster hinge pins of the brake, and the lever. Remove both pins and re-insert them after positioning the thruster on the pin holes in the base and lever of the brake. Replace both split pins, Check that the thruster movement is unobstructed when the crank lever is pulled manually and the thrust rod of the thruster moves freely. Open the terminal box cover of the thruster and connect 3-phase, 415 Volts power supply cables to the three terminals on the terminal plate inside the terminal box. Terminate the earthing lead on the earth terminal provided on the thruster or brake. Replace the terminal box cover on the terminal box. The thruster is ready for operation.

ALIGNING AND SETTING OF BRAKE :

Next, align the brake shoes with the diameter and surface of the brake drum and adjust the nuts on the tie-rod such that both shoes grip the brake drum equally. Energize the power cables. This will cause the thrust rod of the thruster to move up and the brake is released as the shoes release the brake drum. Adjust the gap between the drum and shoes to 0.3 to 0.5, equally by adjusting the setting bolts on both arms.

For equal and uniform liner wear it is necessary to ensure that the shoes and the arms move equally. This is done automatically by the ball on one arm and a matching vee on the other arm.

Technical Data :

DRUM DIAMETER	BRAKING TORQUE
100 mm (4") x 18 kg	06 kgm
150 mm (6") x 18 kg	09 kgm
160 mm (6") x 18 kg	09 kgm
200 mm (8") x 18 kg	020 kgm
200 mm (8") x 34 kg	032 kgm
250 mm (10") x 18 kg	035 kgm
250 mm (10") x 34 kg	042 kgm
300 mm (12") x 18 kg	042 kgm
300 mm (12") x 34 kg	062 kgm
400 mm (16") x 34 kg	090 kgm
400 mm (16") x 46 kg	110 kgm
400 mm (16") x 68 kg	170 kgm
500 mm (20") x 46 kg	190 kgm
500 mm (20") x 68 kg	290 kgm
500 mm (20") x 114 kg	485 kgm
600 mm (24") x 68 kg	350 kgm
600 mm (24") x 114 kg	580 kgm

INTRODUCTION

Thruster brake is a device to retard the speed of moving machinery and to stop it accurately to the desired position. The braking force is applied to the brake shoes by a pre-stressed compression spring. The shoes press on the rotating brake drum retarding its speed, and finally stopping it. The releasing of the brake and compressing of the spring is done by thruster. Other release devices like pneumatic cylinder or manual release arrangements can be offered on request.

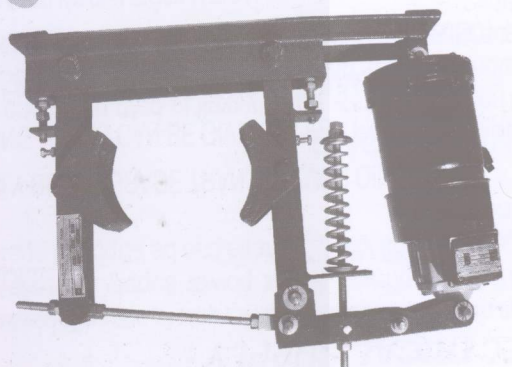

CONSTRUCTION AND OPERATION

Thruster brake has a pair of cast iron shoes which are lined up with friction pads. The shoes are hinged on main arm and side arm of the brake. Each of them have a hinge pin fitted in the base. They are connected to each other on top by a tie rod which is hinged in the main arm and locked to the swivel block in the side arm by a lock nut.

A crank lever is hinged on the main arm and the other end is fixed to the top clevis of the thruster by a hinge pin. A brake spring, is fixed on the main arm and is pre-loaded by a locknut on the lever, The pre-tension in this spring decides the braking torque. The thruster is fitted on the base by a hinge pin. When the thruster is not energized, the brake shoes are pressed on the brake drum fitted on the drive motor shaft and hold it under the effect of braking force provided by the spring in such condition, the brake is applied and the drum cannot rotate.

When the thruster motor is energized, the thrust provided by the thruster lifts up the crank lever which move the arms and the shoes away from the brake drum, there by releasing the braking force. The spring is compressed and braking energy is stored for the next cycle.

FOUNDATION

To install the brake, the foundation must be made ready with tapped holes of proper size as per the dimensions mentioned in the dimension table. Care must be taken to ensure the center line of the brake coincides with the centerline of the brake drum and also the level of mounting pads "h" is matching with the center height of the brake drum.

ELECTRO HYDRAULIC THRUSTOR BRAKES COMPLETE CHART

C = SHOE WIDTH

D = DRUM DIA

M = THRUSTOR STROKE

O = SHOE ANGLE

NOTE :- (1) USE ONLY BS-148 GRADE TRANSFORMER OIL

(2) MOUNTING HOLES CAN BE GIVEN AS PER PARTY REQUIREMENT

(3) WHERE F=0, THERE 'E' TREAT UP TO DRUM CENTER.

(4) FOR QUALITY IMPROVEMENT DIMENSION ARE SUBJECT TO CHANGE WITHOUT INFORMATION.

SELECTION OF BRAKE SIZE

Brake torque Of **180** to **250%** of motor rated torque is sufficient for normal applications like Cranes, Hoist and other material handling equipments, For **CT** and **LT** drives, braking torque of **180** to **150%** of motor rated torque will ensure braking without excessive noise and mechanical jerk.

Rated Motor Torque is given by

$$T = \frac{716.2 \times \text{HP}}{\text{RPM}} \quad \text{OR} \quad \frac{975 \times \text{KW}}{\text{RPM}}$$

Where, KW or HP is motor rated power and RPM is motor rated speed in revolution per minute.

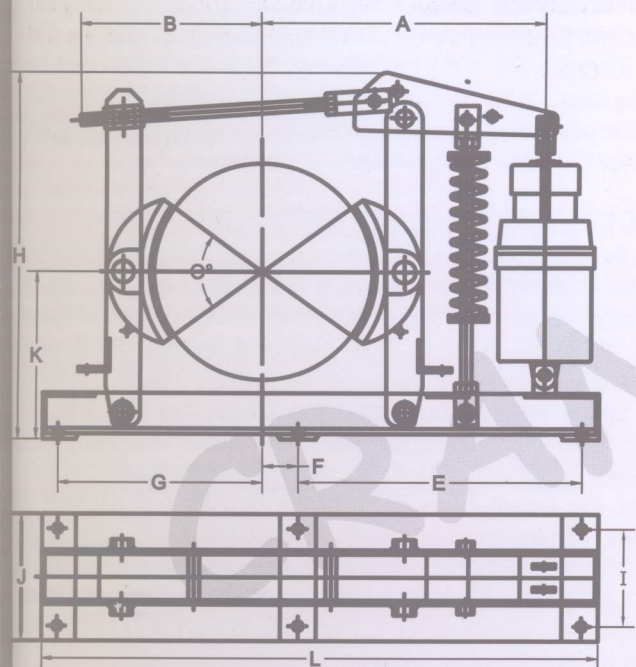

DIA	100	150	160	200	200	250	250	300	300	400	400	400	500	500	500	600	600
CAPACITY	18	18	18	18	34	18	34	18	34	34	46	68	46	68	114	68	114
A	250	270	270	345	420	355	365	445	445	520	520	590	618	630	630	688	688
B	150	175	175	200	230	260	232	270	270	370	370	370	410	430	430	480	480
C	65	65	65	90	90	115	110	145	145	165	165	165	200	225	225	240	240
E	135	150	150	354.5	260	290	325.5	355	355	510	510	510	680	520	520	765	765
F	----	----	----	----	172	----	----	105	105	65	65	65	150	140	140	150	150
G	115	100	100	175.5	208	195	194.5	240	240	380	380	380	380	395	395	465	465
H	450	420	420	435	510	490	561	590	560	750	750	578	857	900	900	970	970
I	100	100	100	125	125	120	130	145	145	180	180	180	*	215	215	*	*
J	125	125	125	175	170	185	185	205	205	235	235	235	302	260	260	322	322
K	125	125	125	200	200	225	225	275	275	310	310	310	417	417	417	475	475
L	440	470	480	570	680	640	675	750	750	1015	1015	1015	1130	1130	1130	1300	1300
M	51.8	51.8	51.8	51.8	51.8	51.8	51.8	51.8	51.8	51.8	51.8	76	51.8	76	76	76	76
O°	70°	70°	72°	90°	90°	90°	90°	90°	90°	90°	90°	90°	90°	90°	90°	90°	90°
P	6	9	9	20	32	35	42	42	62	90	110	170	190	290	485	350	580

ELECTRO HYDRAULIC THRUSTORS (ST)

ELECTRICAL SUPPLY :

Unless otherwise specified, all thrusters are suitable for operation for **415 Volts**, -phase, **50 Hz** power supply. Thrusters for other voltages up to **600 VAC**, 3-phase can be supplied against specific enquiries.

CONNECTIONS :

The Thrusters operate equally well in both directions of rotation. Therefore, the three phase supply lines can be connected with the Thrusters in any R-Y-B phase sequence. Provide adequate safety backups.

OIL REQUIREMENTS :

Thrusters are supplied without oil to avoid spillage during transportation. They must be filled with sufficient quantity of oil before installation. For all models of thrusters, it is recommended to use **Transformer Oil** as specified in **BS : 148**.

Oil capacity requirements are listed in the table below.

INSTALLATION OF THRUSTERS :

All Thrusters are suitable for vertical mounting only. After filling the thruster with required quantity of oil, install it by using the clevis and hinge pins provided. Insert the locking split pins.

Ensure that no excessive transverse forces are acting on the thrust rod. Wipe out the dust, paint or oil deposits from the operating section of the thrust rod pins by dry and clean cloth.

MAINTENANCE :

The Thrusters is designed for long trouble free service. The motor windings are designed to meet contingencies, The bearings are adequately sized.

Routine maintenance schedule includes checking the oil levels and topping them if necessary. If oil contamination is detected, drain it out completely and refill with fresh oil. Check and correct the oil leakage if detected.

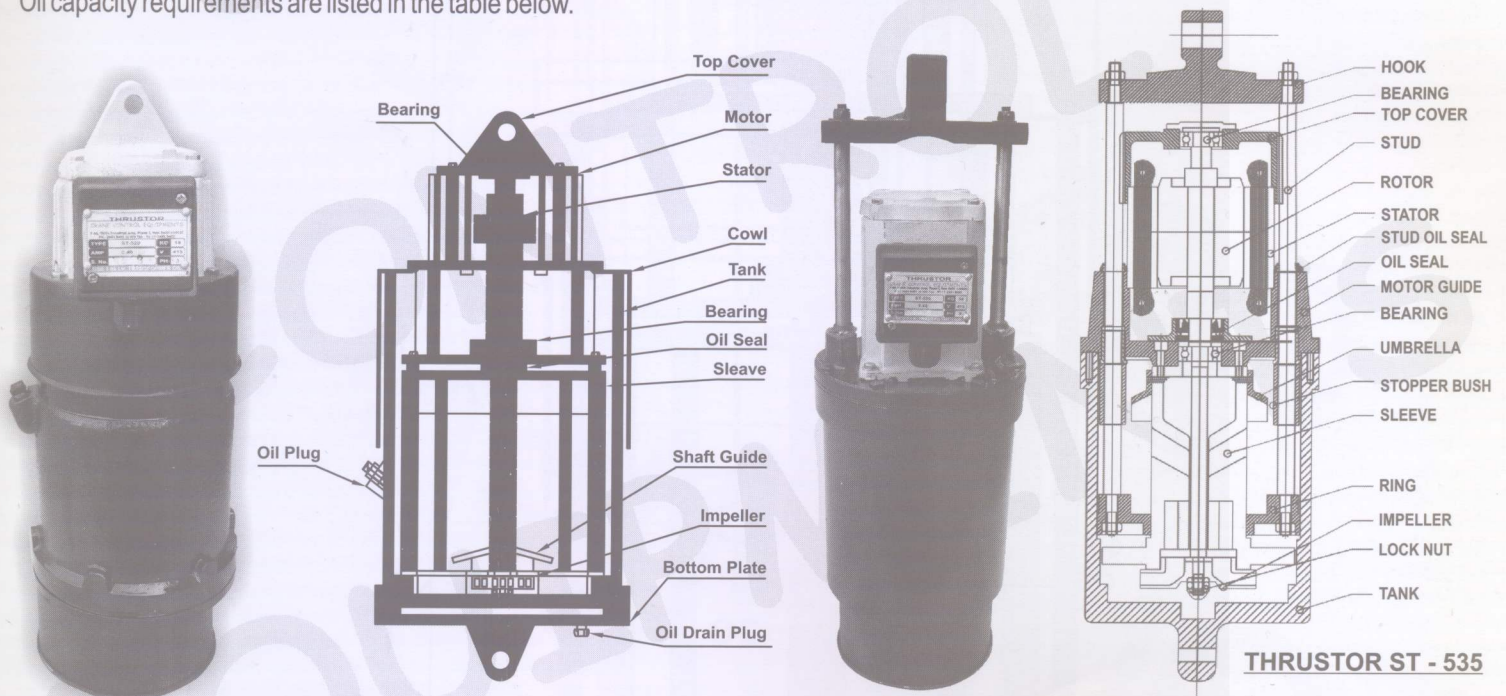

DIMENSIONS

TYPE	RATED THRUST KGS. (N)	OUTPUT STROKE MM.	INPUT WATTS	A	B	C	D	E	F	G	H	J	K	L	M	P	Q	WT. (KG.)	OIL CAPACITY LITERS
ST 520	18 (180)	51	90	349	51	159	19	25	13	12.7	19	16	19	32	19	110	90	14	1.85
ST 535	34 (340)		150	444		171	22	29	14	19.7		21	27	41	25	138	118	30	2.5
ST 545	45 (450)		180																
ST 870	68 (680)	76	200	508	76	216	25	32	16	22.2	25	24	29	48	32	152	132	40	4.5
ST 8110	114 (1140)		250																
ST 13200	225 (2250)	127	420	660	127	254	32	38	19	25.4	30	27	45	54	38	152	132	55	9.0
ST 13300	295 (2950)		580																

ELECTRO HYDRAULIC THRUSTORS (DRAWING 18 KG)

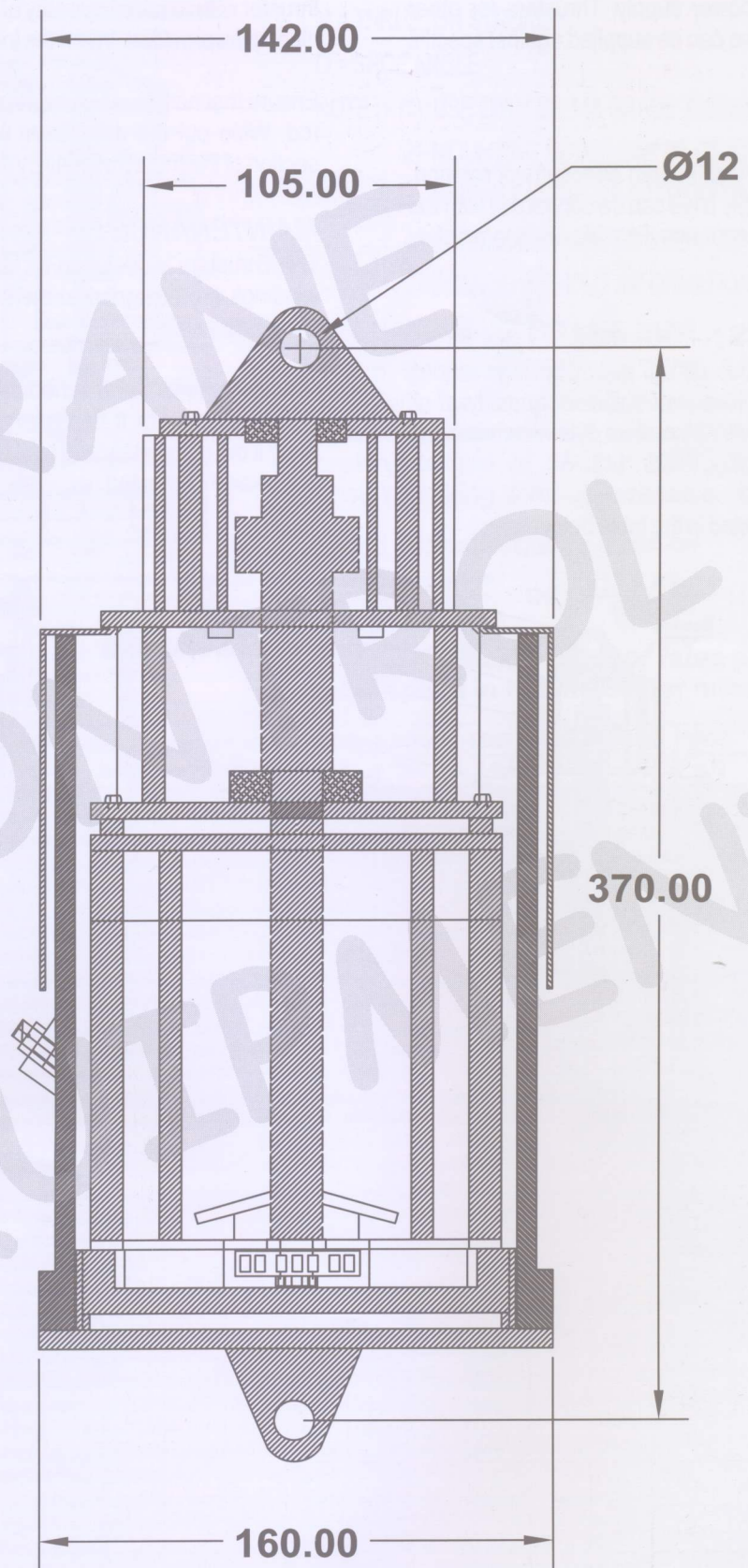

ELECTRO HYDRAULIC THRUSTORS (DRAWING 34 / 114 KG)

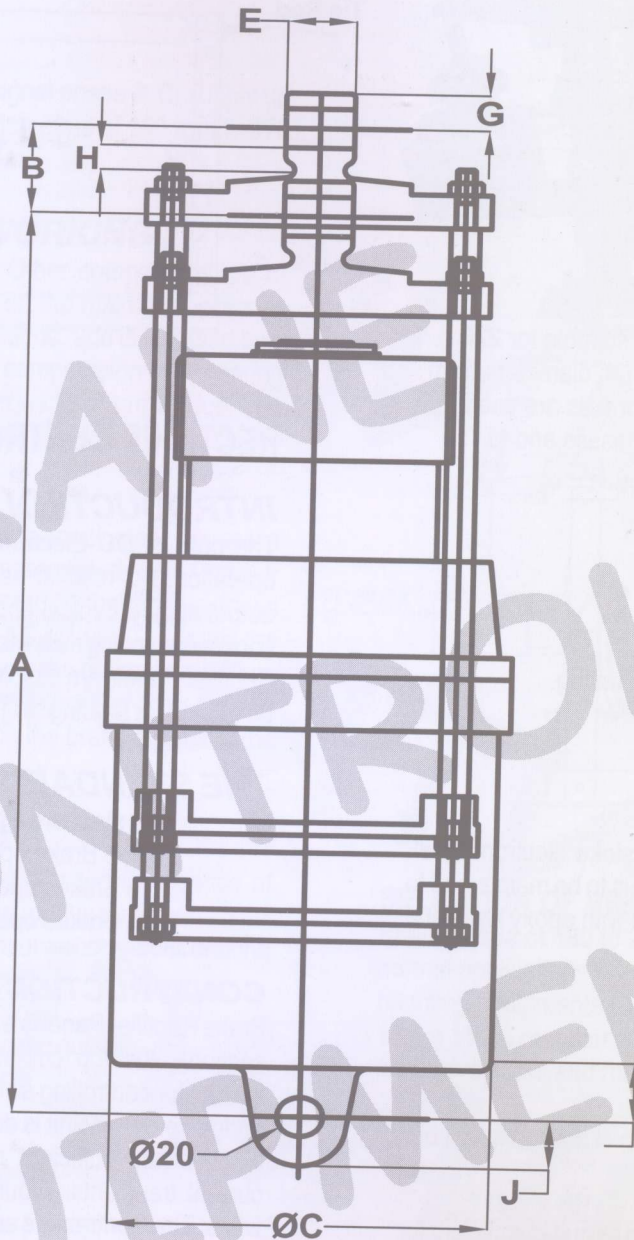

TYPE	RATED OUTPUT		INPUT WATTS.	DIMENSIONS IN MM										WT. KGS.	CAPACITY LITERS
	THRUSTOR KGS.	STROKE MM.		A	B	C	D	E	G	H	J	K	L		
ST - 535	34	51	150	470	51	166	30	38	18	28	22	25	46	30	2.5
ST - 545	46	51	180	470	51	166	30	38	18	28	22	25	46	30	2.5
ST - 870	68	76	200	500	76	205	28	32	18	30	25	24	47	40	4.5
ST - 8110	114	76	220	500	76	205	30	34	20	30	25	30	40	40	4.5

D.C. ELECTRO - MAGNETIC BRAKES

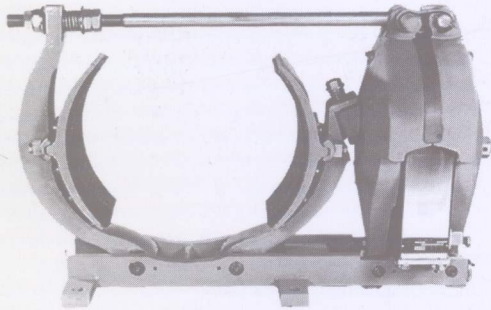

INTRODUCTION

Mill duty D.C. Electro-Magnetic Brakes are suitable for 220 Volts D.C. supply and are available for a drum diameters from 100mm to 800mm D.C. Electro-Magnetic brakes are used to retard or to stop moving loads or rotating masses and to prevent damage to men and equipments.

FEATURES

1. Robust construction and simple design.
2. Reliable braking action.
3. Efficient transmission of forces.
4. Brakes shoes replacement without dismounting.
5. Ease of maintenance.
6. Ease of torque adjustment.

AIR GAP

The brake is released by powerful, short stroke electromagnet. The gap between the coil and the armature is to be maintained to about 0.3 mm. Brake coil is encapsulated with epoxy resin and is 'Class F' insulation.

TECHNICAL DATA

Class of insulation of coil-'F'
Maximum operative voltage-660V
Rated supply-220V, D.C.

SELECTION OF BRAKE SIZE

Brake torque of 180 to 250% of motor rated torque is sufficient for normal applications like Cranes, Hoists and other material handling equipments, For CT and LT drives, braking torque of 180 to 150% of motor rated torque will ensure braking without excessive noise and mechanical jerk.
Rated motor torque is given by

$$M_b = T = \frac{716.2 \times \text{HP}}{\text{RPM}} \quad \text{OR} \quad \frac{975 \times \text{KW}}{\text{RPM}}$$

Where, KW or HP is motor rated power and RPM is motor rated speed in revolutions per minute.

BRAKE SIZE	DRUM DIA (mm)	BRAKE TORQUE Kg-m	BRAKE SIZE	DRUM DIA (mm)	BRAKE TORQUE Kg-m
DM 100	100	1.6	DM 400	400	120
DM 150	150	10.0	DM 500	500	190
DM 160	160	10.0	DM 600	600	355
DM 200	200	12.5	DM 700	700	575
DM 250	250	35	DM 800	800	910
DM 300	300	50			
DM 315	315	50			

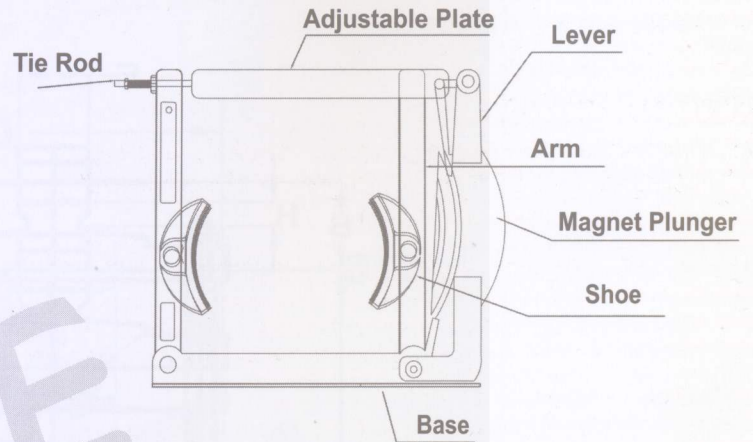

RECTIFIER CONTROL FOR D. C. BRAKES

INTRODUCTION

The coils of DC Electromagnetic brakes need DC supply for operation. DC rectifier panel converts AC mains supply to DC output supply. Typical application examples are E.O.T. Cranes, conveyors, rolling mills etc. Rectifier Panels are supplied with different combinations and can be offered for feeding single or multiple brake coils.

THE STANDARD PANELS

The standard Panels can be offered for Single Brake operated individually, or Two Brakes operated individually, or Two Brakes operated simultaneously.

CONSTRUCTION

Brake Rectifier Panel is a fabricated sheet enclosure and has two sections, the top compartment is for resistor assembly and bottom for controlling switch gear items like contractors, rectifier bridges etc. The unit is designed for floor mounting. High quality rectifier has sufficient capacity to sustain over-voltage and current transients. Wound Resistors have Nichrome / Eureka wires. The Contractors and Timers are of suitable ratings and are from reputed manufacturers.

DEGREE OF PROTECTION

The standard enclosure for rectifier unit conforms to IP-54 degree of protection as per IS : 13947 (Part I) - 1993. The Resistor unit is IP 23.

FINISHING

Sheet steel enclosures are given metal treatment process for de-rusting, de-greasing, and phosphating prior to two coats of synthetic enamel paint.

VOLTAGE RATING

Input - 415V AC Output - 220V DC (With economic resistor)
Control Voltage - 110V, 220V, 240V, 415V AC.

A.C. ELECTROMAGNETIC BRAKES

INTRODUCTION

A.C. Drum Brakes are suitable for signal phase A.C. supply up to 440V and are available for drum diameters of 100 mm to 375 mm and Braking Torques up to 69 kg-m.

CONSTRUCTION AND WORKING :

The shoes are of graded cast iron. Other components are of fabricated steel. The lever is hinged on the main arm, which is connected to the side arm through a tie rod, and is stressed by a pre-loaded compression spring. The compression of the spring can be adjusted to set the braking torque to desired value. The brake liners are of selected quality material and are riveted to the shoes by aluminum rivets.

A.C. solenoid with laminated magnetic sheet steel houses a copper magnetizing coil which is impregnated with Class F materials. The plunger which is connected to the lever, is drawn in to the coil, when it is energized with AC source. This loads the spring and release the brake shoes from the brake drum. When the supply is cut off, the plunger is pulled out of the coil, and spring force clamps the brake shoes on the brake drum and the brake is applied.

FEATURES :

1. The brake is Fail-safe. The brake is applied in absence of A.C. Current and is released when the supply is restored.
2. High quality brake lining material ensures consistent braking torque and reliable operation.
3. Clean environment working and less noise.
4. Braking torque can be adjusted easily and quickly.
5. Ease of maintenance.

Notes

1. Brake type EMS 4 denotes A.C. single phase 4" drum diameter (inch series)
2. Brake type EMS 100 denotes A.C. single phase 100 mm drum diameter (metric series)
3. Brakes are made to suit the required Drum Diameter.
4. Coils are rated for operation on single phase, 400/ 440V, 50 cycles,
5. Coils can be supplied with 'class B' insulation.
6. Coil for higher ambient temperature upto 60°C can be offered on Request,
7. Tolerance on indicated dimensions is $\pm 2\text{mm}$.
8. Higher braking torque can be adjusted for reduced CDF Duty.

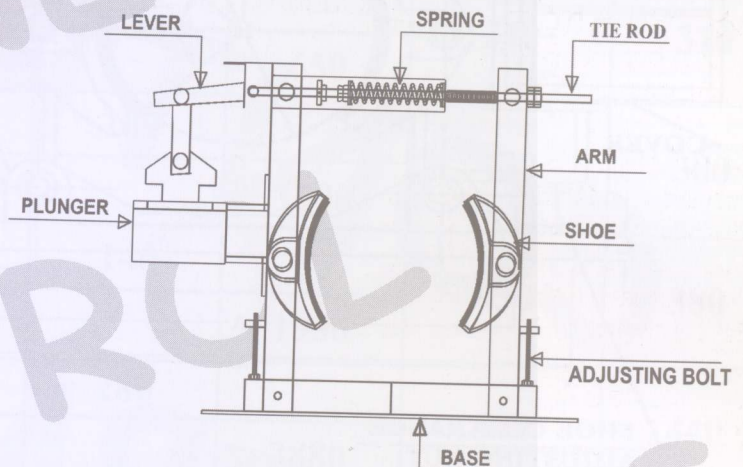
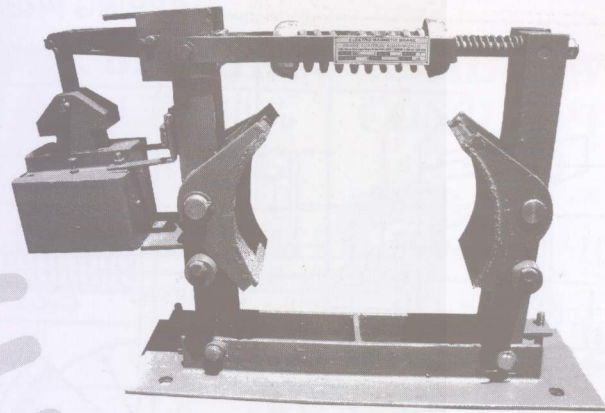

SELECTION OF BRAKE SIZE

Brake torque of 180 to 250% of motor rated torque is sufficient for normal applications like Cranes, Hoists and other material handling equipments, For CT and LT drives, braking torque of 180 to 150% of motor rated torque will ensure braking without excessive noise and mechanical jerk.

Rated Motor Torque is given by

$$T = \frac{716.2 \times \text{HP}}{\text{RPM}} \quad \text{OR} \quad \frac{975 \times \text{KW}}{\text{RPM}}$$

Where, KW or HP is motor rated power and RPM is motor rated speed in revolutions per minute.

Dimensional Details

Brake Type	Drum dia.		Braking Torque kg. M.
	inch	mm	
EMS - 4" EMS - 100	4	100	1.87
EMS - 6" EMS - 150	6	150	6.5
EMS - 8" EMS - 200	8	200	15
EMS - 10" EMS - 250	10	250	19.3
EMS - 12" EMS - 300	12	300	38.8
EMS - 15" EMS - 380	15	380	58.6

A.C. ELECTROMAGNETIC BRAKES CHART

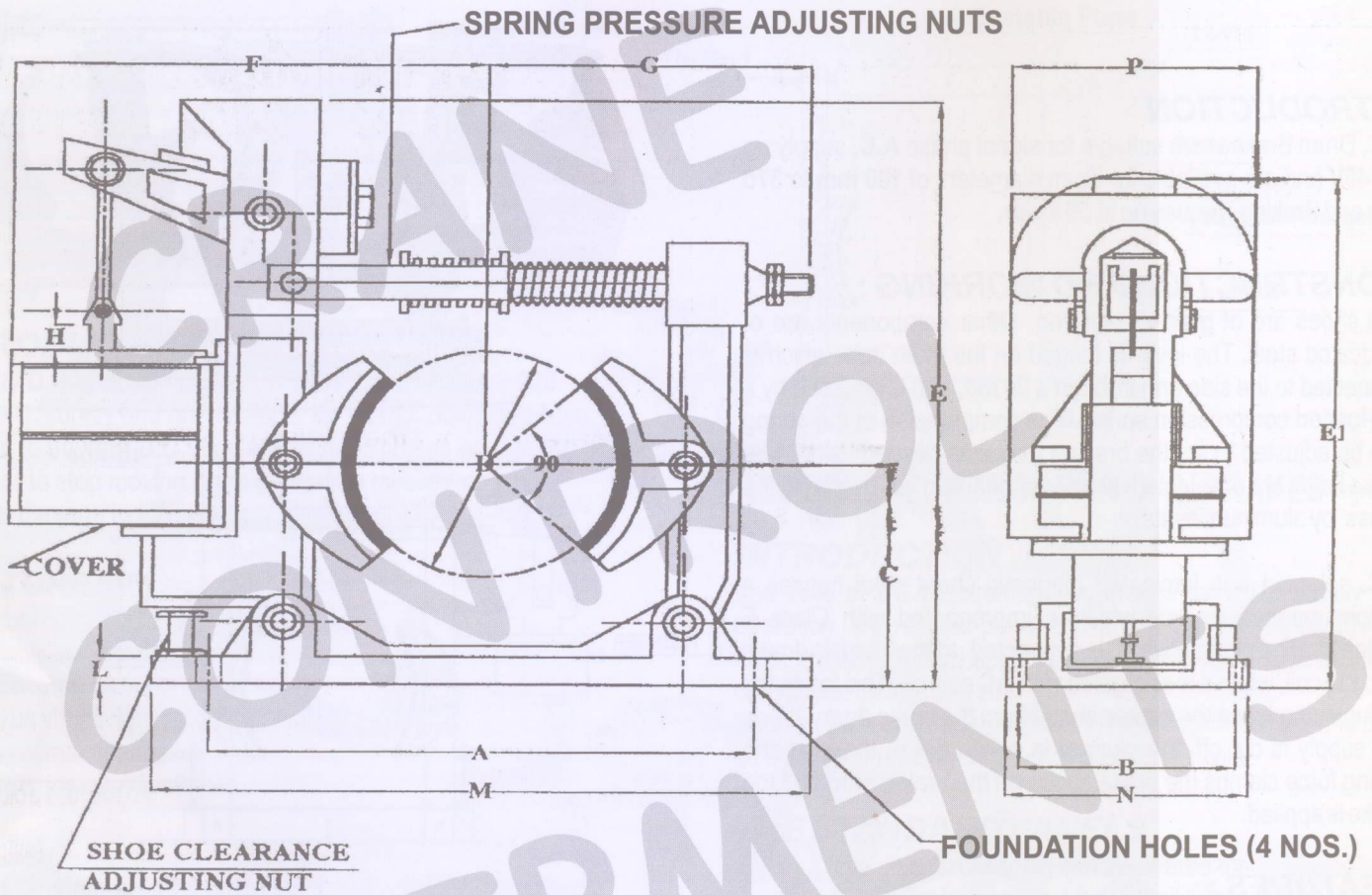

BRAKE TYPE	DRUM DIA-D	A	B	C	E (MAX)	E1 (MAX)	F (MAX)	G	H	J	K	L	M	N	O	WT.KG (APPX.)
EMS-4	4"	232	70	130	275	295	230	140	19	10	57	14	267	98	155	13.0
EMS-100	100MM															
EMS-6	6"	310	76	130	305	325	260	175	19	10	70	18	340	114	155	18.5
EMS-150	100MM															
EMS-8	8"	400	92	175	370	390	340	235	19	14	89	20	441	126	175	30.8
EMS-200	100MM															
EMS-10	10"	470	114	225	460	480	380	275	19	14	100	23	500	150	175	43.5
EMS-250	250MM															
EMS-12	12"	530	152	254	530	552	445	320	19	20	127	23	616	210	190	78.0
EMS-300	300MM															
EMS-15	15"	610	190	315	645	667	495	355	19	22	152	28	680	229	190	97.0
EMS-380	380MM															

NOTES:-

- (1) BRAKE TYPE EMS 4 DENOTES AC SINGLE PHASE 4" DIA (INCH SERIES).
- (2) BRAKE TYPE EMS 100 DENOTES AC SINGLE PHASE 100 DAI (METRIC SERIES).
- (3) BRAKES ARE MADE TO SUIT EITHER INCH OR METRIC DRUM SIZE.
- (4) BRAKES ALTHOUGH ARE CALLED AC SINGLE PHASE BUT ARE OPERATED ON TWO PHASE 440 VOLTS AC SUPPLY.

A.C. ELECTROMAGNETIC BRAKES CHART

BRAKE TYPE	DRUM DIA.	MAX. BRAKING TORQUE 50% COIL RATING		MAX. BRAKING TORQUE 100% COIL RATING		COIL POWER CONSUMPTION V. A	
		LB. FT	KG. CM	LB. FT	KG. CM	50%	100%
EMS - 4	4"	15.9		13.5		310	310
EMS - 100	100MM		200		187		
EMS - 6	6"	55		47		310	310
EMS - 150	150MM		760		650		
EMS - 8	8"	128		109		430	380
EMS - 200	200MM		1775		1500		
EMS - 10	10"	164		140		430	380
EMS - 250	250MM		2270		1930		
EMS - 12	12"	330		280		500	440
EMS - 300	300MM		4570		3880		
EMS - 15	15"	500		425		500	440
EMS - 380	380MM		6900		5860		

NOTES :-

CLASS 'A' INSULATED

- (1) COILS ARE RATED FOR OPERATION ON 400/440 VOLTS SINGLE PHASE AC 50 CYCLES.
- (2) BRAKE RATINGS AND COIL POWER CONSUMPTION GIVEN AT 40°C. AMBIENT.
- (3) COILS CAN BE SUPPLIED WITH CLASS 'B' INSULATION FOR OPERATION AT HIGHER AMBIENT TEMPERATURE UP TO 60°C.
- (4) COIL POWER CONSUMPTION INDICATED IS OVERATED VALUE AT AN OPERATION VOLTAGE OF 415 VOLTS AC SINGLE PHASE 50 CYCLES.

RESISTANCE BOXES (WIRE GRID & PUNCH GRID)

INTRODUCTION

Resistance boxes are used to add resistance in an electric motor circuit for modifying the performance characteristic of Slip Ring Electric Motors of EOT Cranes, Rubber Mills, Steel Rolling Mills, Cement Plants, Power Plants, Conveyors, Coke Oven, Blowers etc. for speed control and developing starting torque with low starting currents. They are also used as Dynamic Breaking Resistor for V.V.F.A.C. Drives, electric loading of AC Altimeters, DC Generators and Dynamometers.

Resistors are designed to meet requirements of both A.C. & D.C. Application.

TYPE OF RESISTORS :

The basic types of resistors are gap :

1. Stainless steel Wire Grid Resistors
2. Stainless Steel Punched Grid Resistors
3. Fechral Punched Grid Resistors

CURRENT RATINGS :

Resistors are manufactured for current ratings from 10 to 800 Amps. Continuous duty resistors of higher ratings are made by using two - or more parallel paths. Resistors with short time rating up to 3000 Amps (or even higher), for neutral earthing are possible for system voltage up to and above 11 KV.

STAINLESS STEEL WIRE GRID RESISTORS :

These resistors consist of stainless steel wires or strip in form of grids. The current rating generally range from 7 Amps to 100 Amps for continuous duty applications with single or multiple paths.

STAINLESS STEEL GRID RESISTORS :

Punched steel grid resistors consist of grids punched from corrosion resisting nickel chromium alloy sheet steels. The punched steel grids are completely immune to shock & vibration. They function reliably under the worst operating conditions and are particularly suited for steel mill duty. These resistors are available in wide range of current ratings from 8 Amps to 800 Amps for continuous duty with single or multiple parallel paths.

FEATURES :

Enclosure material	Galvanized Sheet Steel (Hotdip)
Mounting	Floor mounting
Degree of protection	IP - 21 / 22 / 23.
Current Rating (SS W-Grid)	7 to 100 Amps Continues.
Current Rating (SS P-Grid)	7 to 800 Amps, Continues.
Cooling	Air Cooled
Temperature rise	225° / 250° / 375° C
Cable Entry	Bottom

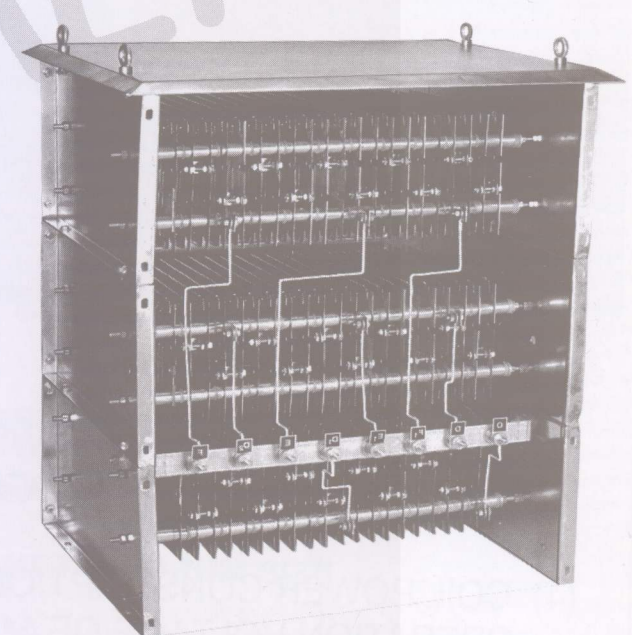
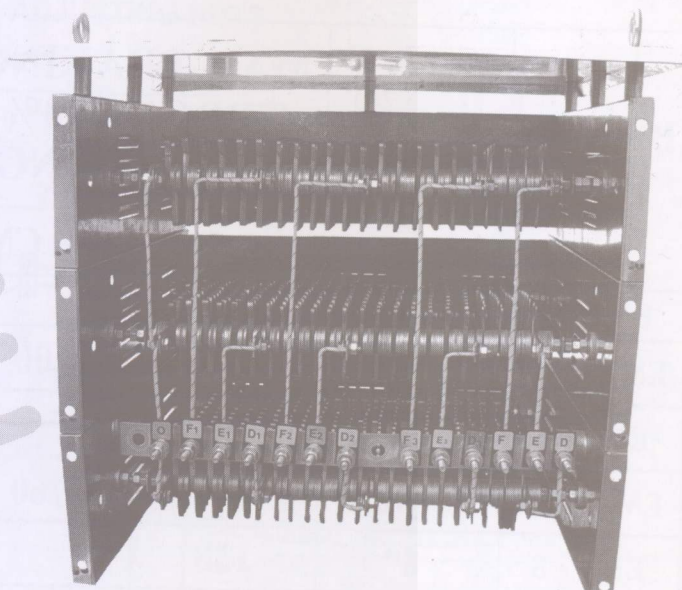

DIMENSION DETAIL OF RESISTANCE BOXES

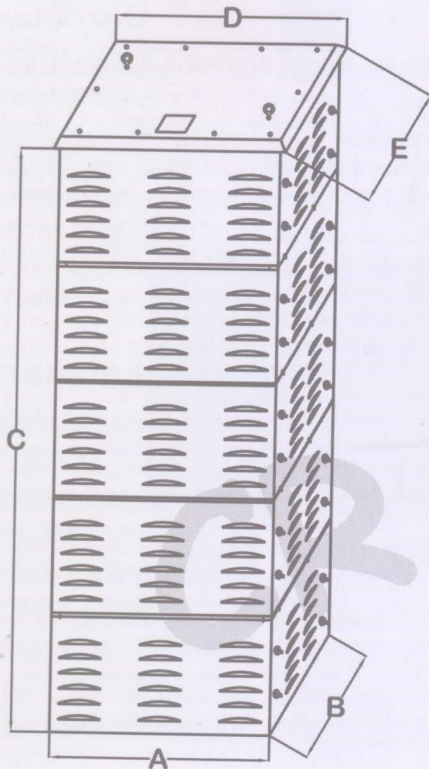

S S WIRE GRID TYPE

TYPE	LENGTH (A)	WIDTH (B)	HEIGHT (C)	TOP COVER (D)	COVER (E)
1 S-380	380	460	210	600	600
2 S-380	380	460	390	600	600
1 L	600	460	210	760	630
2 L	600	460	390	760	630
3 L	600	460	570	760	630
4 L	600	460	750	760	630
5 L	600	460	930	760	630

S S PUNCHED GRID TYPE

TYPE	LENGTH (A)	WIDTH (B)	HEIGHT (C)	TOP COVER (D)	COVER (E)
1 SS	380	530	320	440	600
1 S	530	530	320	600	600
2 S	530	530	600	600	600
1 L	680	530	320	760	630
2 L	680	530	600	760	630
3 L	680	530	880	760	630
4 L	630	530	1160	760	630
5 L	630	530	1440	760	630
1L-830	830	530	320	900	630
2L-830	830	530	600	900	630
3L-830	830	530	880	900	630
4L-830	830	530	1160	900	630
5L-830	830	530	1440	900	630
1 L	1160	530	320	1250	645
2 L	1160	530	600	1250	645
3 L	1160	530	880	1250	645
4 L	1160	530	1160	1250	645
5 L	1160	530	1440	1250	645

ALL DIMENSIONS ARE IN MM

In case of 3 Steps the no. of connections shall be 9 nos where as in case of 4 Steps the no. of connections shall be 12 nos

CONNECTION DIAGRAM OF RESISTANCE BOXES

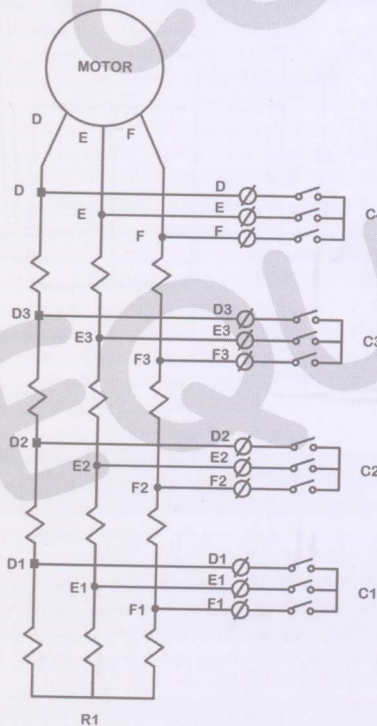

C1-C4 = RESISTANCE CONTACTOR
 R1 = RESISTANCE BOX
 D-F3 = TERMINALS OF RESISTANCE BOX

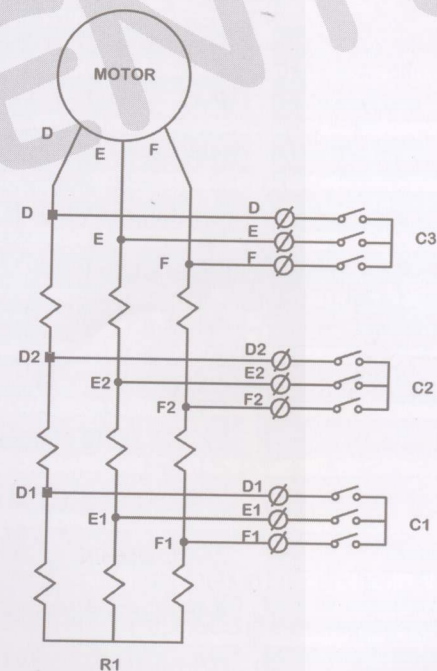

C1-C3 = RESISTANCE CONTACTOR
 R1 = RESISTANCE BOX
 D-F2 = TERMINALS OF RESISTANCE BO

DUAL MASTER CONTROLLERS

GENERAL

Dual Master Controller with one universal handle allows a crane operator to control both Bridge & Trolley motions with one handle. Simultaneous operation of Bridge & Trolley motions provide for greater spotting accuracy and faster movement of loads. The handle of joystick can be moved into any quadrant and any position. Universal controllers are also used for hoist / grab motion. Master controllers are coupled with universal joint for operation of controller individually / jointly to get desired motion operation.

TECHNICAL DATA

Body material	MS Sheet (Powder Coated)
Protection	IP - 41
Contacts material	Silver Cadmium
Contacts	Single Bracket
Rated voltage insulation	500 Volts A.C.
Thermal test current	40 Amps.
Cable entries	1x20, 1x26 standard conduit
No of Contacts	16 per Controller (max.)
Max. No. of notches	6-0-6 maximum

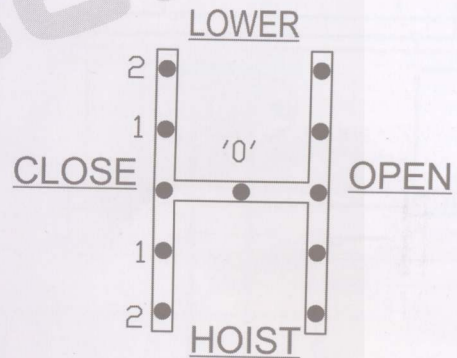
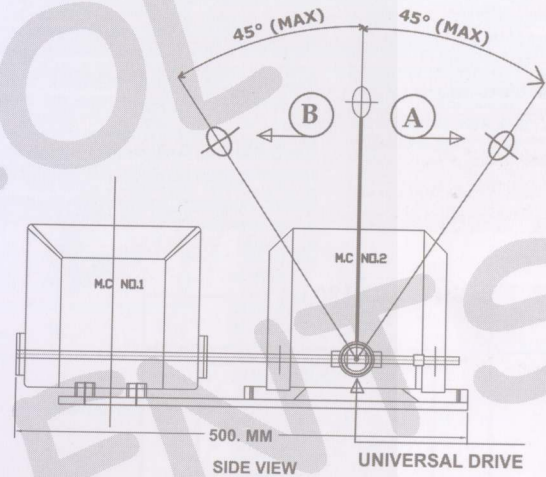
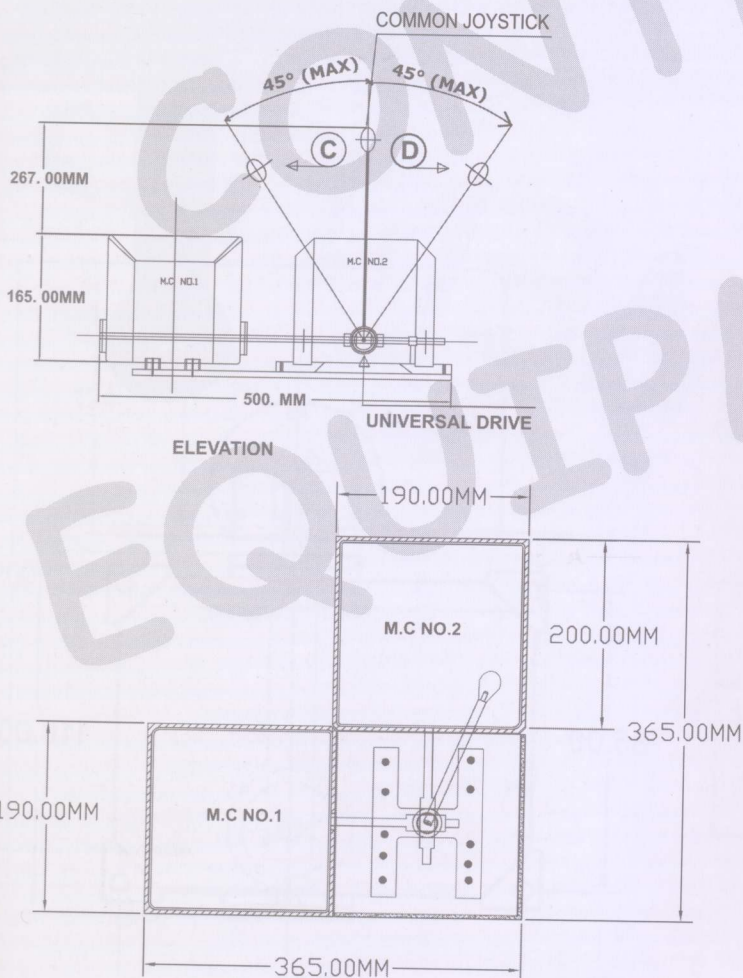

Note :

- 1) Master Controller no.1 operates in the direction -'a'&'b'2
- 2) Master Controller no.2 operates in the direction -'c'&'d'
- 3) Max. No. Of cams per controller - 16.
- 4) No. Of cable entries a) dia. 20-2 nos.zz
b) dia. 26-2 nos.zz

LEVER LIMIT SWITCHES

INTRODUCTION:

Lever type Limit Switch operates the control change-over Contacts of motor of an moving equipment when a Cam moving with load actuates the Lever of limit switch. This turns the cams on a square shaft and operates the **NO / NC** contact elements. These Limit Switch are used for controlling over travel of linear motion

OPERATION :

Two or more Contact Elements are operated by respective rotating Cams, which are suitably fixed on a square Cam Shaft turned by a lever

DESIGN : ALUMINIUM CAST BODY

The Aluminium Cast body, Lever and Cover of the Limit Switch are finished by powder coating treatment. The Cam Shaft is mounted in the housing on moulded Nylon bushes (bearing) and are fixed through the front & rear walls.

TECHNICAL DATA :

Body Material	Powder Coated Aluminium Cast
Degree of Protection	IP- 55
Mounting Position	Floor Mounting
Cable Entries	Twin. 3/4' BS Conduit
No. of Contact	2 / 3 / 4
Wire Connection	Silver-Cadmimum
Rated Voltage	500 V AC
Thermal Test Current	40 Amps

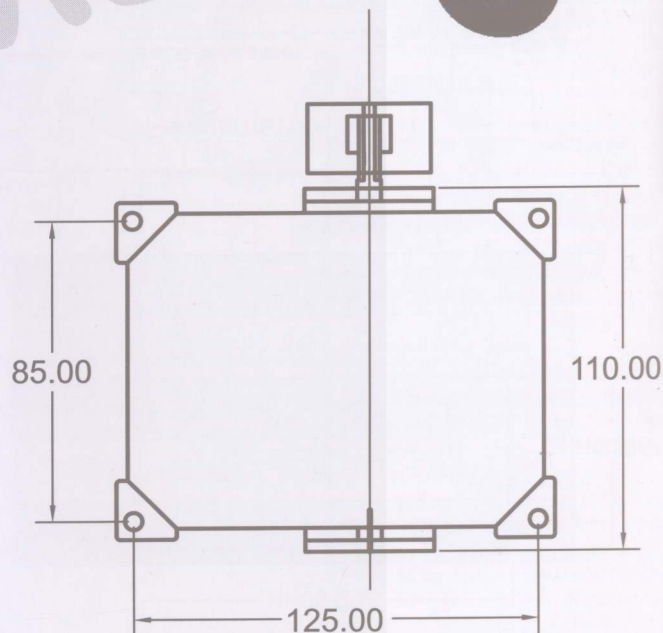
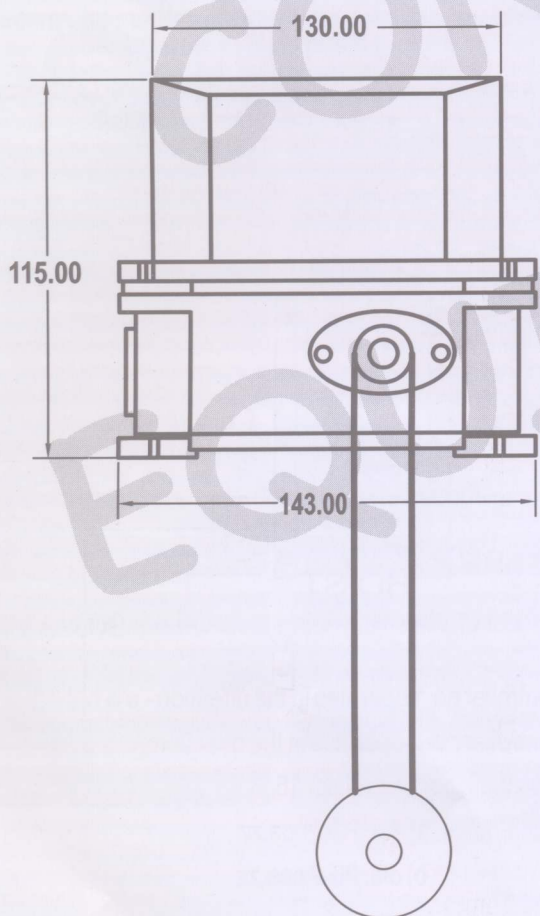

LEVER LIMIT SWITCHES

INTRODUCTION:

Lever type Limit Switch operates the control change-over Contacts of motor of an moving equipment when a Cam moving with load actuates the Lever of limit switch. This turns the cams on a square shaft and operates the **NO / NC** contact elements. These Limit Switch are used for controlling over travel of linear motion

OPERATION :

Two or more Contact Elements are operated by respective rotating Cams, which are suitably fixed on a square Cam Shaft turned by a lever.

DESIGN : M S SHEET BODY

The M S Sheet body, Lever and Cover of the Limit Switch are finished by powder coating treatment. The Cam Shaft is mounted in the housing on moulded Nylon bushes (bearing) and are fixed through the front & rear walls.

TECHNICAL DATA :

Body Material	Powder Coated Sheet
Degree of Protection	IP-41
Mounting Position	Floor Mounting
Cable Entries	Twin. 3/4" BS Conduit
No. of Contact	2 / 3 / 4
Wire Connection	Silver-Cadmimum
Rated Voltage	500 V AC
Thermal Test Current	40 Amps

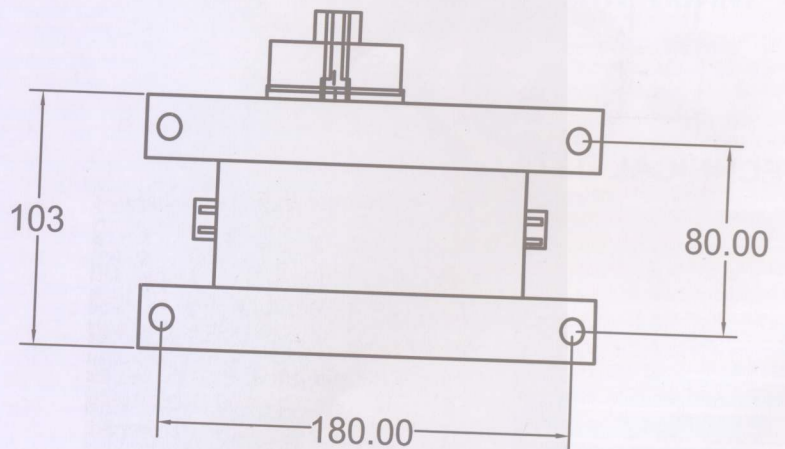
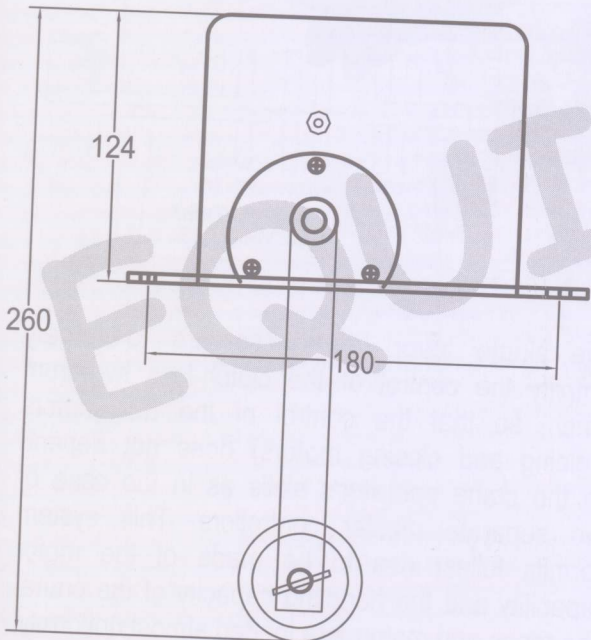
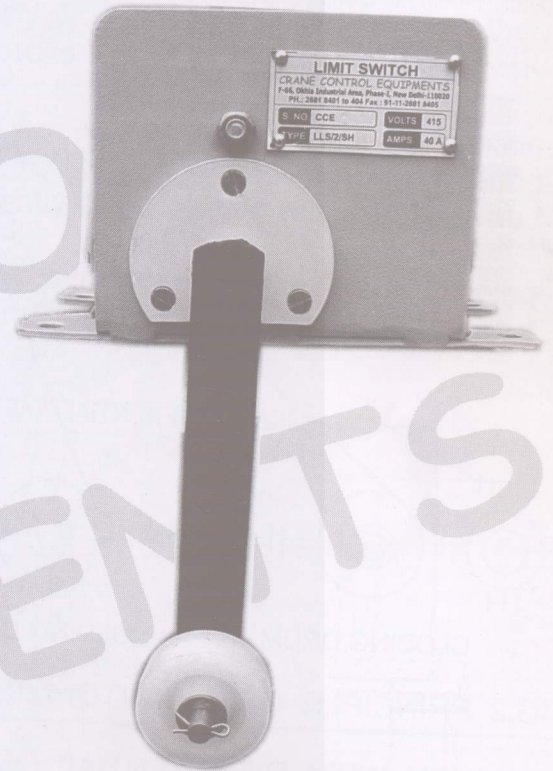

DIFFERENTIAL LIMIT SWITCHES

INTRODUCTION:

Differential type Limit Switch operates the control change-over Contacts of motor of an moving equipment when a Cam moving with load actuates the Differential of limit switch. This turns the cams on a square shaft and operates the **NO / NC** contact elements. These Limit Switch are used for controlling over travel of linear motion

OPERATION :

Two or more Contact Elements are operated by respective rotating Cams, which are suitably fixed on a square Cam Shaft turned by a lever

DESIGN : CAST BODY

The Aluminium Cast body, Lever and Cover of the Differential Limit Switch are finished by powder coating treatment. The Cam Shaft is mounted in the housing on moulded Nylon bushes (bearing) and are fixed through the front & rear walls.

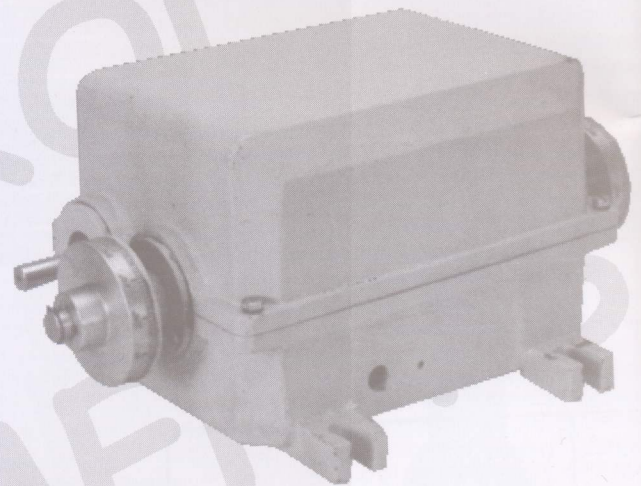
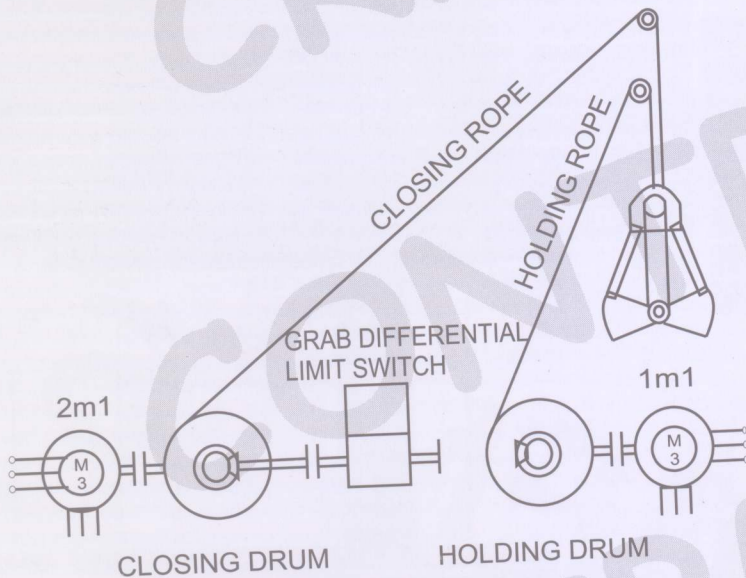

FIG.2 PRINCIPLE OF A CLUTCHLESS TWO DRUM

WINCH WITH DIFFERENTIAL LIMIT SWITCH

TECHNICAL DATA :

Body Material	Powder Coated Aluminium Cast
Degree of Protection	IP- 41
Mounting Position	Floor Mounting
Cable Entries	Twin. 3/4' BS Conduit
No. of Contact	2 / 3 / 4
Wire Connection	Silver-Cadmimum
Rated Voltage	500 V AC
Thermal Test Current	40 Amps

The single lever control serves to largely simplify the control of the clutch-less two-drum winch, so that the control of the two motors (holding and closing motors) does not depend on the crane operator's skills as in the case of two separate master controllers. This system permits fullest use to be made of the motor capability and the handling capacity of the crane. The ropes and motors are loaded almost uniformly. Overloading of motors is prevented

DIFFERENTIAL LIMIT SWITCHES

Simple Operation with only one lever. The lever is guided in a gate. This prevents mal-operation and also permits employment of inexperienced crane operators

Automatic limit switching performed by the grab differential limit switch in all positions i.e., limitation of the closing and opening motion of the grab at any height, limitation at the highest and lowest grab position independently of the closing position

Automatic transition from grabbing to raising without slack rope and loss of time. Automatic distribution of the load over the two ropes.

Utilization of the maximum handling capacity of the crane by semi-automatic contactor control of the motors i.e., maximum possible acceleration of the raising and lowering motions No overloading of the motors due to uneven load on the two ropes and excessive current peaks due to moving the control switch too rapidly from one extreme to the other. The motor capacity is fully utilized, but the motors are not stressed unduly

Only two control position each for raising and lowering viz., one position for slow motion and one for full speed. Approximately equal speed of the motors at all raising and lowering position without a mechanical coupling. This prevents accidently opening or closing of the grab..

It is possible for the control system to be used to link both motors for hook service, the grab being removed for the purpose. Special circuit connection and additional devices are then required

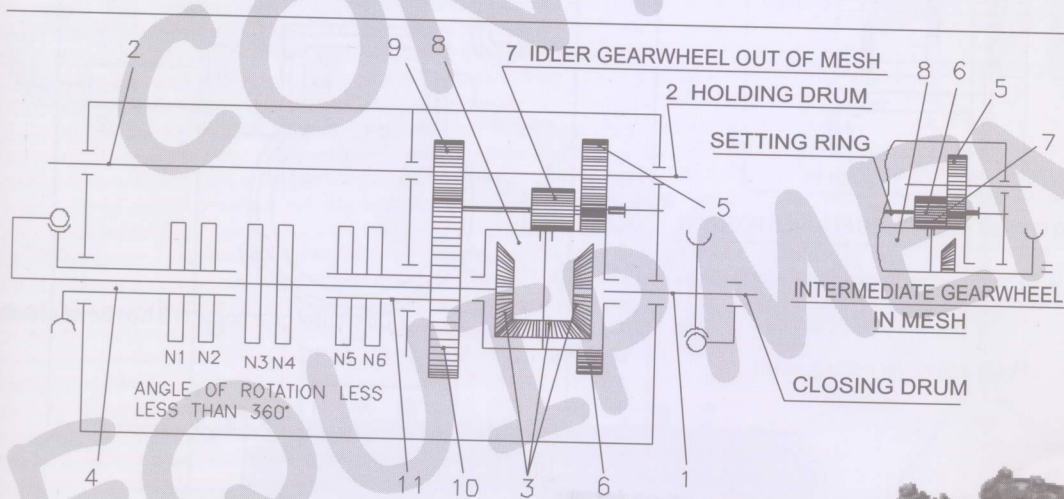
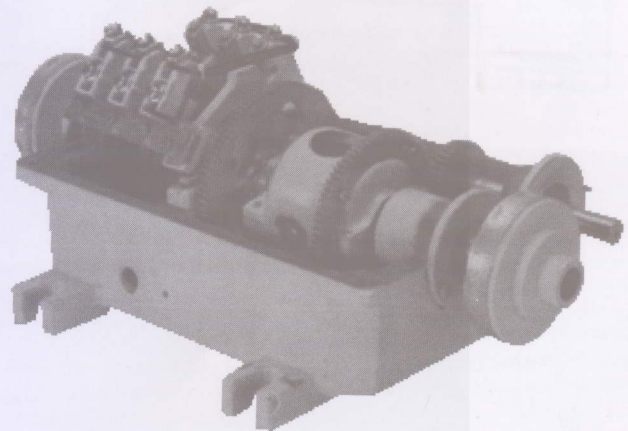
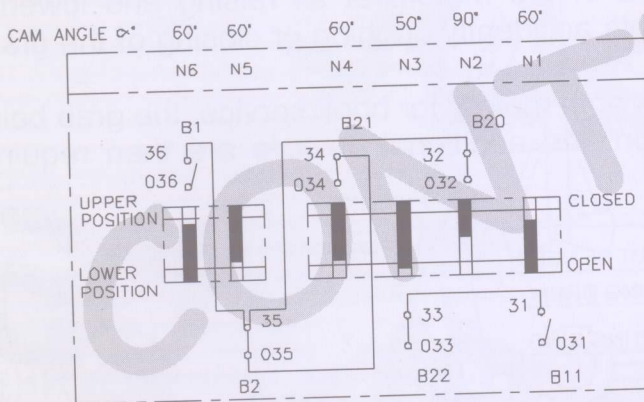

FIG. 6 DIFFERENTIAL LIMIT SWITCH



DIFFERENTIAL LIMIT SWITCHES

N1	b11	31 - 031	Limit Switch	"Grab Closed"	60
N2	b20	32 - 032	Loading Contact	Initiation of hoisting when traversing the controller to "Hoisting" via "Closing". Slowing down the closing motor shortly before closing is completed	290
N3	b22	33 - 033	Intermidate Switch	Prevention of slack rope at the various operating conditions	50
N4	b21	34 - 034	Limit Switch	"Grab Opened"	60
N5	b2	35 - 035	Limit Switch	"Lowest Grab Position"	60
N6	b11	36 - 036	Limit Switch	"Highest Grab Position"	60



DIFFERENTIAL LIMIT SWITCH WITH GRAB BUCKET CLOSED AND IN UPPER POSITION.

FIG. 7 INTERNAL WIRING AND ASSEMBLY DIAGRAM OF DIFFERENTIAL LIMIT SWITCH

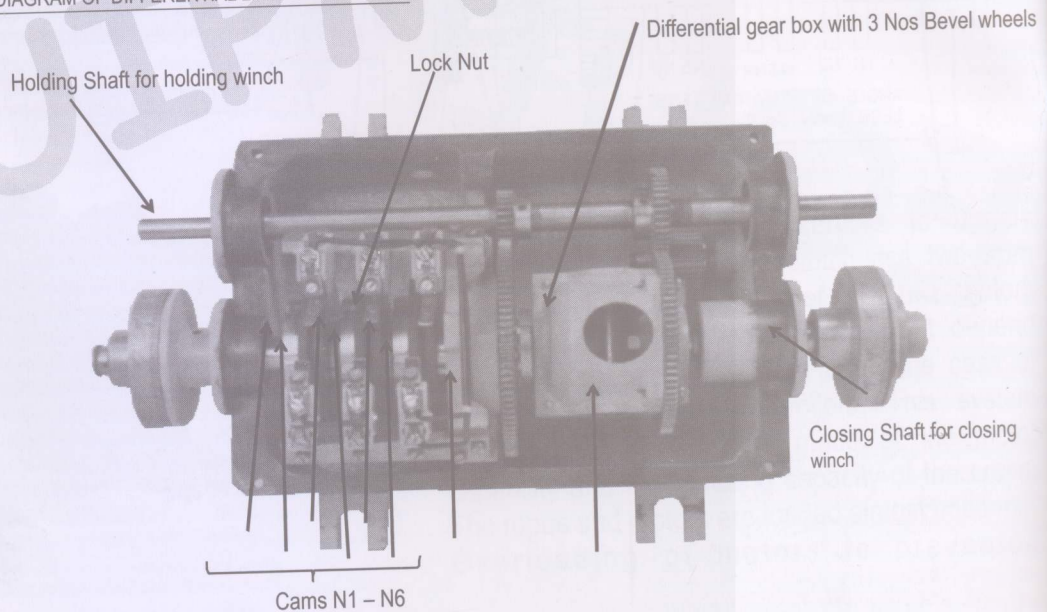

GEARED ROTARY LIMIT SWITCHES (GRLS) - ALUMINIUM ENCLOSURE

INTRODUCTION :

Geared Rotary Limit Switch **GRLS** is used to trip supply when the moving loads reach the extreme end positions of working zone. These are available in **IP - 55** enclosure. The **Contact Tips** are of **Silver Cadmium** and designed for **40 amps** rating.

OPERATION :

Two (or more) **Contact Elements** are operated by respective **Rotating Cams**, suitably adjusted on a **Cam Shaft** which rotates with fixed speed ratio of the drive **Motor Shaft**. The Cams can be suitably positioned so that they trip motor supply and stop the motion at the required point of travel.

APPLICATION :

Geared Rotary Limit Switches are suitable for use on reversing drives such as Hoists, Winches, Rolling Mills and various other mechanisms Used in Steel Plants such as Coke Oven, Feeding machinery etc.

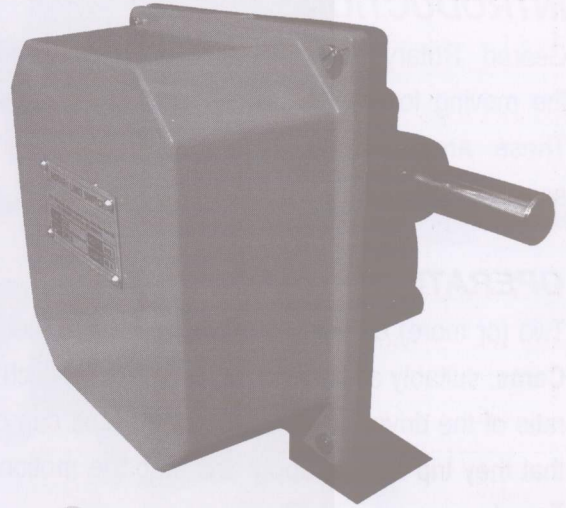

GEARED ROTARY LIMIT SWITCHES (MODEL GRLS) IN ALUMINIUM CASTING ENCLOSURE

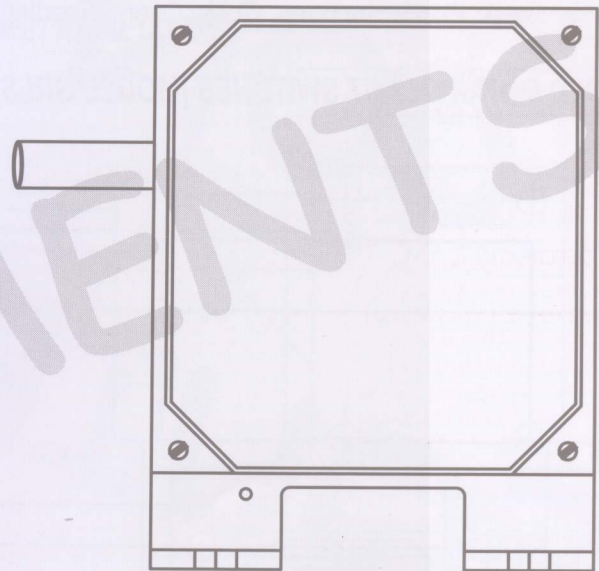
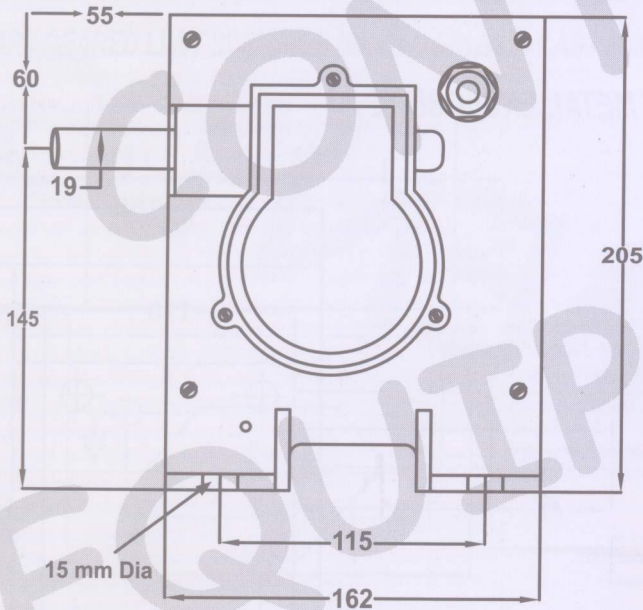

Gear Ratio	Effective Rotation	Usefull Rotation	Type	No of Contacts	Enclosure
48 : 1	42	40	GRLS/48/2SH	2	Aluminium Casting
60 : 1	52	50	GRLS/60/2SH	2	Aluminium Casting
96 : 1	84	80	GRLS/96/2SH	2	Aluminium Casting

GEARED ROTARY LIMIT SWITCHES (GRLS) - SHEET METAL ENCLOSURE

INTRODUCTION :

Geared Rotary Limit Switch **GRLS** is used to trip supply when the moving loads reach the extreme end positions of working zone. These are available in **IP - 41** enclosure. The **Contact Tips** are of **Silver Cadmium** and designed for **40 amps** rating.

OPERATION :

Two (or more) **Contact Elements** are operated by respective **Rotating Cams**, suitably adjusted on a **Cam Shaft** which rotates with fixed speed ratio of the drive **Motor Shaft**. The Cams can be suitably positioned so that they trip motor supply and stop the motion at the required point of Travel.

APPLICATION :

Geared Rotary Limit Switches are suitable for use on reversing drives such as Hoists, Winches, Rolling Mills and various other mechanisms Used in Steel Plants such as Coke Oven, Feeding machinery etc.

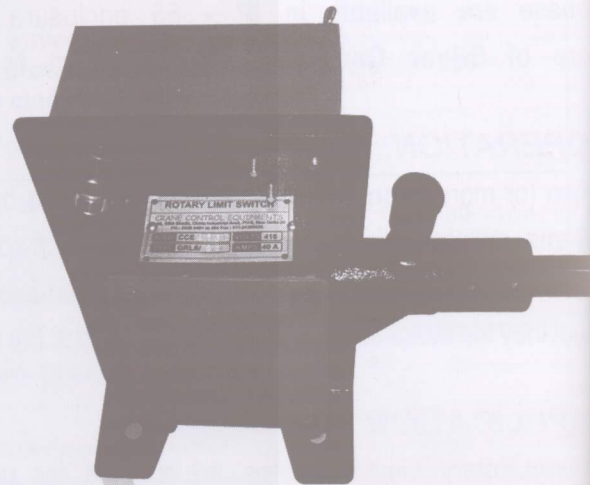

GEARED ROTARY LIMIT SWITCHES (MODEL GRLS) IN SHEET METAL ENCLOSURE

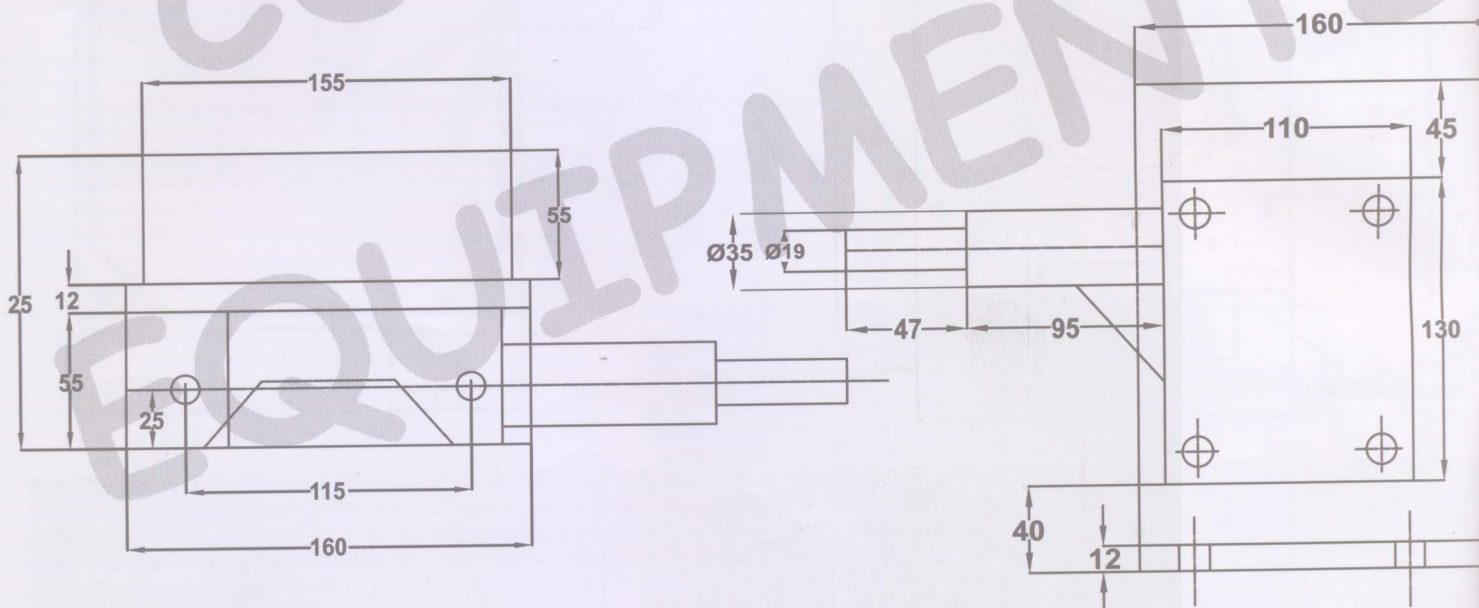

Gear Ratio	Effective Rotation	Usefull Rotation	Type	No of Contacts	Enclosure
48 : 1	42	40	GRLS/48/2SH	2	Cast Iron Base & Sheet Metal Cover

GEARED ROTARY LIMIT SWITCHES (GRLS) CAST IRON / SHEET METAL ENCLOSURE

INTRODUCTION :

Geared Rotary Limit Switch **GRLS** is used to trip supply when the moving loads reach the extreme end positions of working zone. These are available in **IP - 41** enclosure. The **Contact Tips** are of **Silver Cadmium** and designed for **40 amps** rating.

OPERATION :

Two (or more) **Contact Elements** are operated by respective **Rotating Cams**, suitably adjusted on a **Cam Shaft** which rotates with fixed speed ratio of the drive **Motor Shaft**. The Cams can be suitably positioned so that they trip motor supply and stop the motion at the required point of Travel.

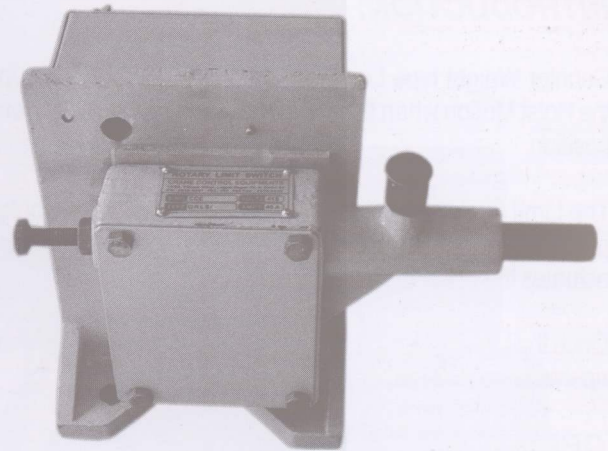

APPLICATION :

Geared Rotary Limit Switches are suitable for use on reversing drives such as Hoists, Winches, Rolling Mills and various other mechanisms Used in Steel Plants such as Coke Oven, Feeding machinery etc.

ROTARY GEARED LIMIT SWITCHES (MODEL GRLS) IN CAST IRON BASE & SHEET METAL COVER

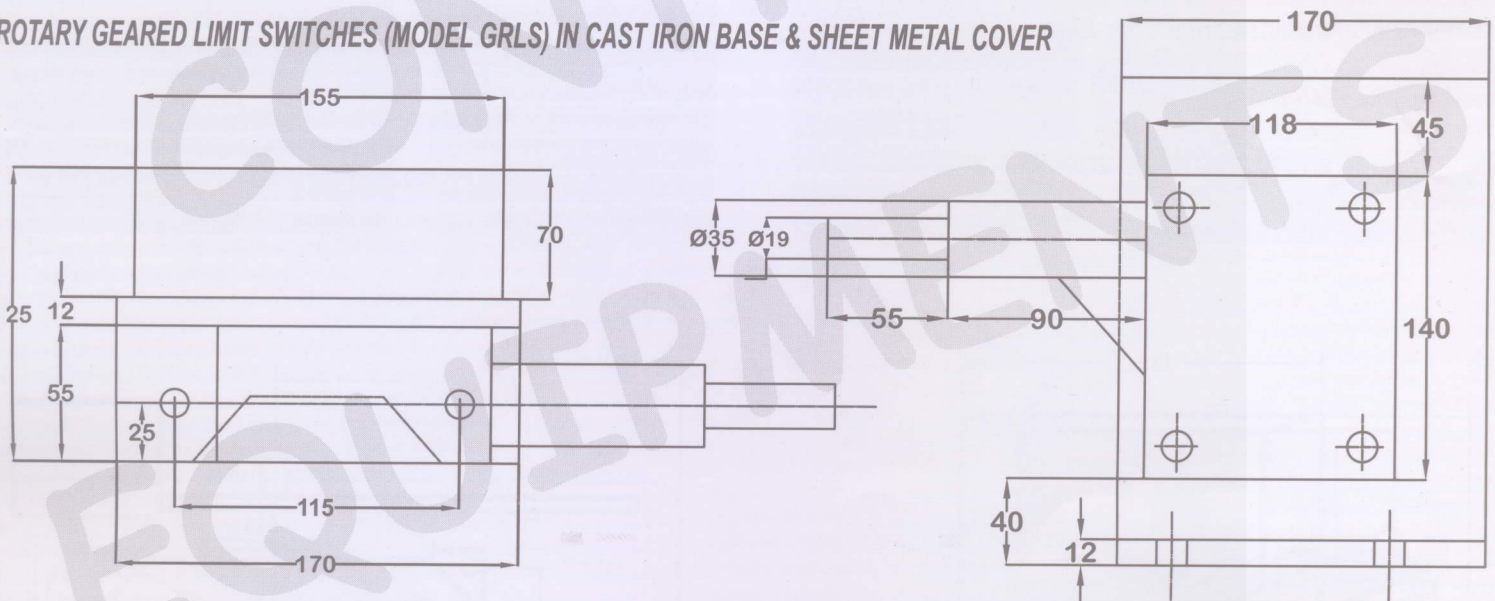

Gear Ratio	Effective Rotation	Usefull Rotation	Type	No of Contacts	Enclosure
48 : 1	42	40	GRLS/48/2SH	2	Cast Iron Base & Sheet Metal Cover
			GRLS/48/4SH	4	
60 : 1	52	50	GRLS/60/2SH	2	Cast Iron Base & Sheet Metal Cover
			GRLS/60/4SH	4	
96 : 1	84	80	GRLS/96/2SH	2	Cast Iron Base & Sheet Metal Cover
			GRLS/96/4SH	4	

COUNTER WEIGHT LIMIT SWITCH - ALUMINIUM ENCLOSURE

INTRODUCTION:

Counter Weight type Limit Switch is used for tripping supply to the Hoist Motion when the Moving Load reaches the extreme top position.

The Limit Switch operates the control change-over Contacts of motor of an moving equipment when a Cam moving with load actuates the Lever of the Limit Switch.

Once the Lever operates it turns the cams on a square shaft and operates the **NO/NC** contact elements.

OPERATION :

Two or more Contact Elements are operated by respective rotating Cams, which are suitably fixed on a square Cam Shaft turned by a lever or weight. The contacts operate at 14° from central neutral position.

DESIGN : ALUMINIUM CAST BODY

The Lever and Cover of the Limit Switches are finished by powder coating treatment. The Cam Shaft is mounted in the housing on moulded Nylon bushes (bearing) and are fixed through the front & rear walls.

The Wire Rope arrangement is in Customer's scope.

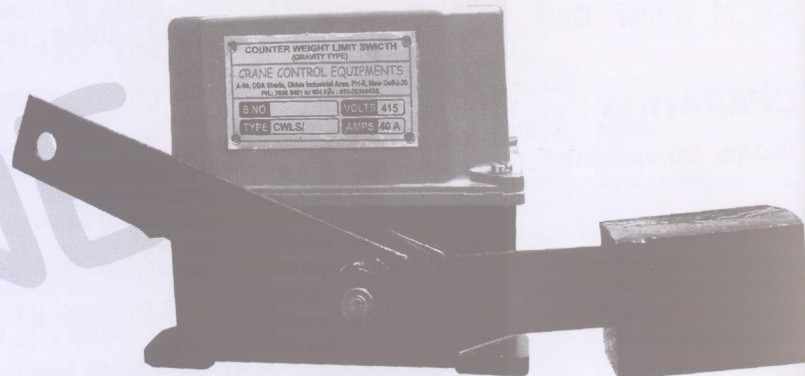

TECHNICAL DATA :

Body Material	Powder Coated Aluminium Cast
Degree of Protection	IP- 55
Mounting Position	Floor Mounting
Cable Entries	Twin. 3/4' BS conduit
No. of Contact	2
Wire Connection	Silver-Cadmimum
Rated Voltage	500 V AC
Thermal Test Current	40 Amps

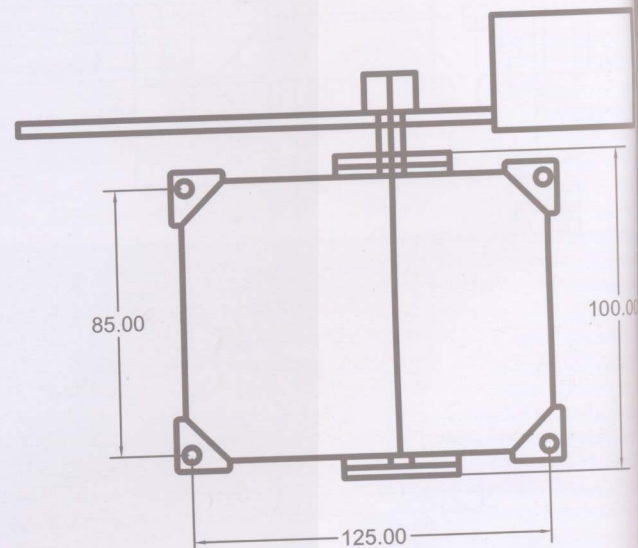
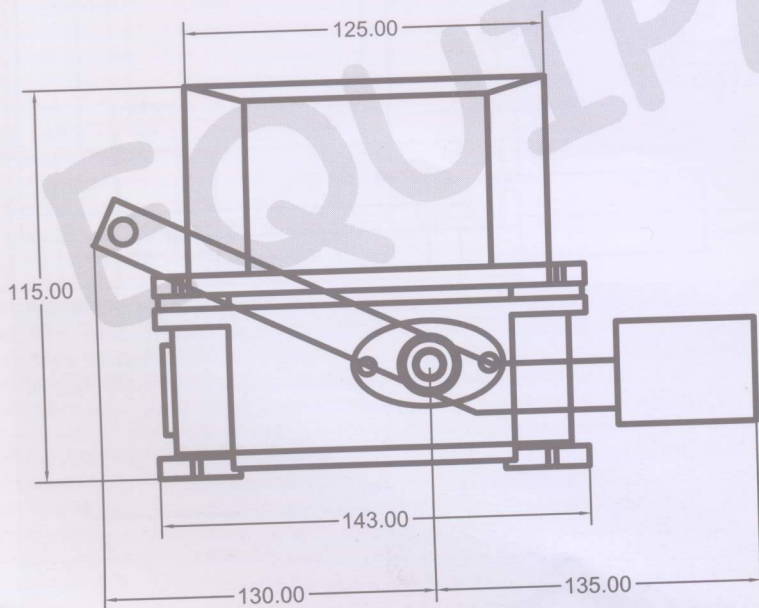

COUNTER WEIGHT LIMIT SWITCH - SHEET METAL ENCLOSURE

INTRODUCTION:

Counter Weight type Limit Switch is used for tripping supply to the Hoist Motion when the Moving Load reaches the extreme top position.

The Limit Switch operates the control change-over Contacts of motor of an moving equipment when a Cam moving with load actuates the Lever of the Limit Switch.

Once the Lever operates it turns the cams on a square shaft and operates the **NO/NC** contact elements.

OPERATION :

Two or more Contact Elements are operated by respective rotating Cams, which are suitably fixed on a square Cam Shaft turned by a lever or weight. The contacts operate at 14° from central neutral position.

DESIGN : M S SHEET BODY

The Lever and Cover of the Limit Switches are finished by powder coating treatment. The Cam Shaft is mounted in the housing on moulded Nylon bushes (bearing) and are fixed through the front & rear walls.

The Wire Rope arrangement is in Customer's scope.

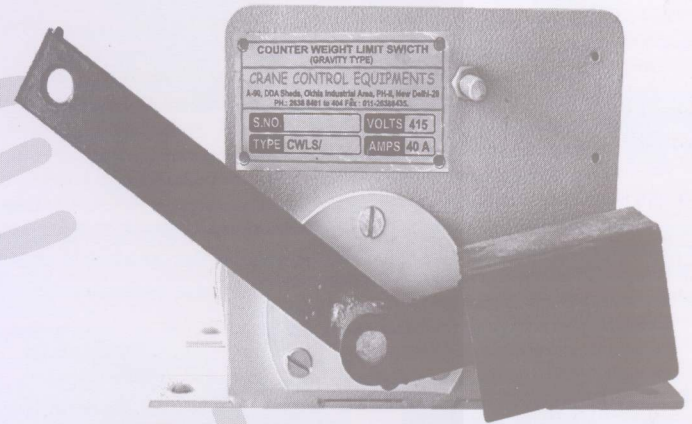

TECHNICAL DATA :

Body Material	Powder Coated Sheet Metal
Degree of Protection	IP- 41
Mounting Position	Floor Mounting
Cable Entries	Twin. 3/4" BS conduit
No. of Contact	2 / 3 / 4
Wire Connection	Silver-Cadmimum
Rated Voltage	500 V AC
Thermal Test Current	40 Amps

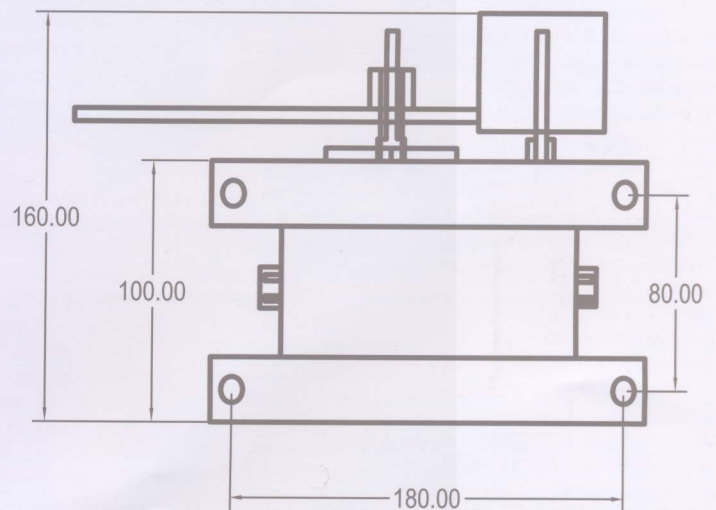
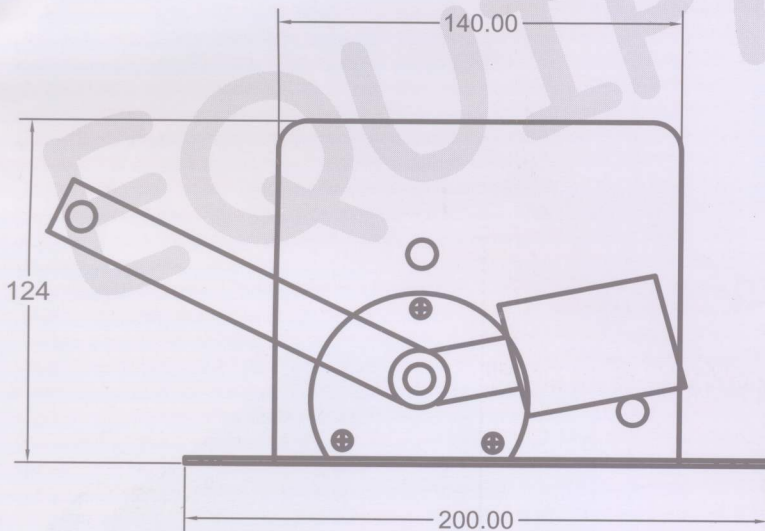

RADIO REMOTE CONTROL

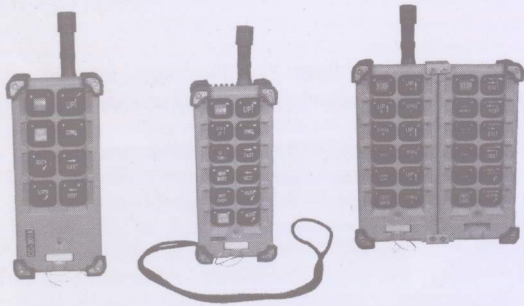

Durability, Reliability

Easy to use, Safe to operate



Economical, Safe to operate

User friendly, Easy to Install

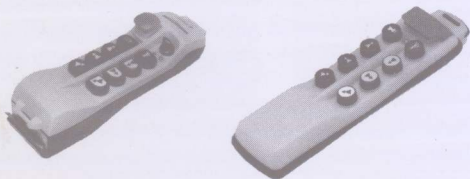

Flexible push button layout

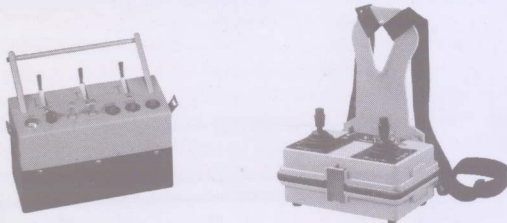

Compact, Choice of colour

Designed as per requirement

Compatible with all CC models

Handy / Compact Transmitter



INSULATED CONDUCTOR BAR

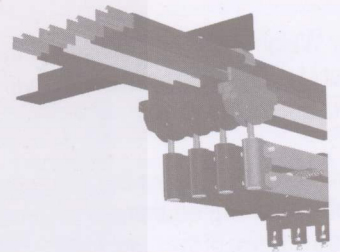

Rating : 60-400 Amps.

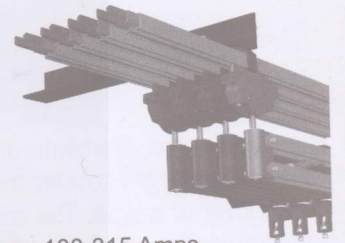

Rating : 100-315 Amps.

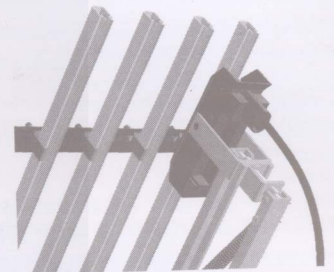

Rating : 60-150 Amps.

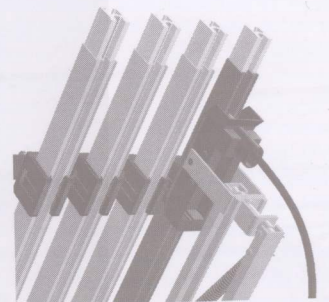

Rating : 500-1500 Amps.



Rating : 75-90 Amps.

CRANE CONTROL EQUIPMENTS

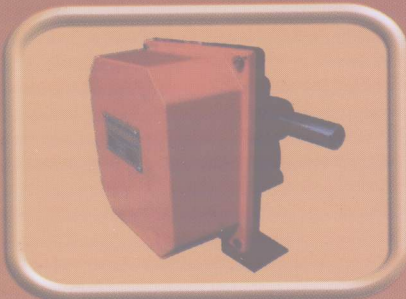

ROTARY GEARED LIMIT SWITCH

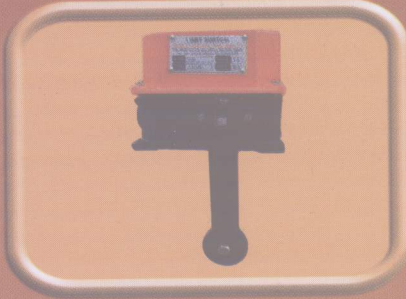

LEVER LIMIT SWITCH

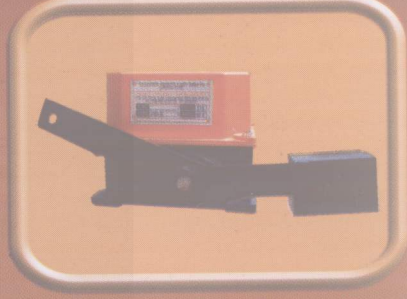

COUNTER WT. LIMIT SWITCH

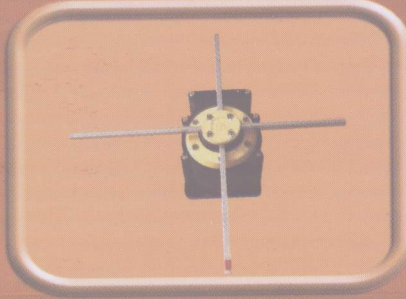

CROSS BAR LIMIT SWITCH



WORM DRIVE LIMIT SWITCH

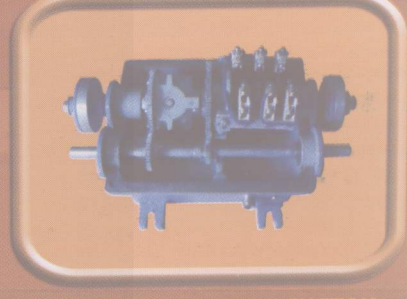

DIFFERENTIAL LIMIT SWITCH

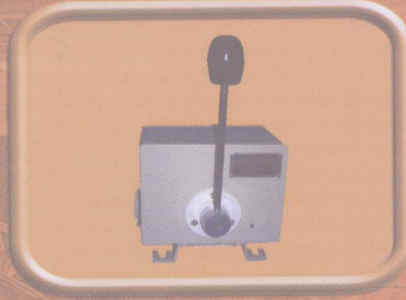

MASTER / CAM CONTROLLER



DUAL MASTER CONTROLLER



PENDANT PUSH BUTTON

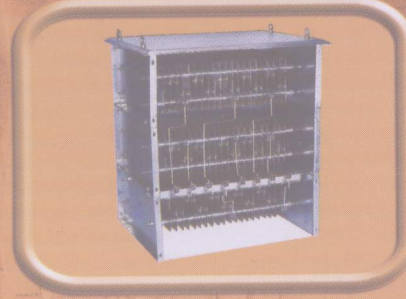

RESISTANCE BOX

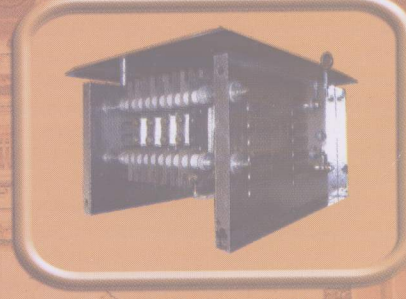

DYNAMIC PUNCHED GRID TYPE

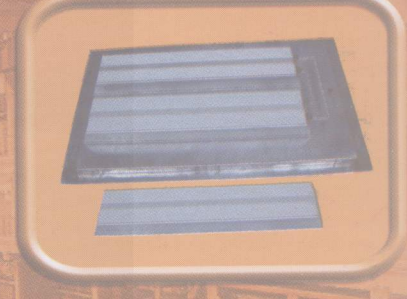

DBR MOULDED TYPE

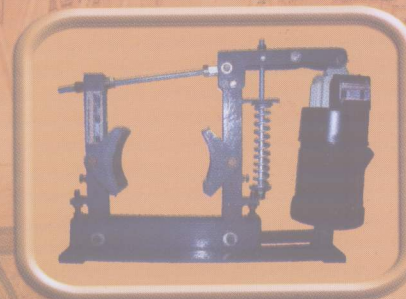

ELECTRO HYDRAULIC THRUSTER BRAKE

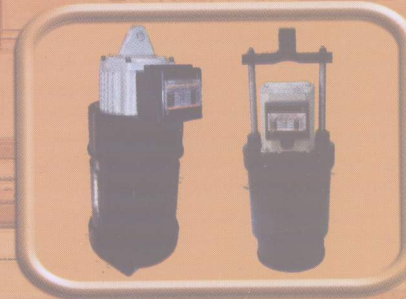

ELECTRO-HYDRAULIC THRUSTERS

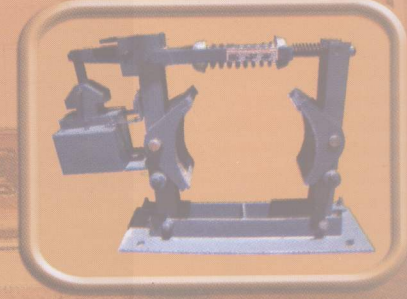

A.C. ELECTROMAGNETIC BRAKE

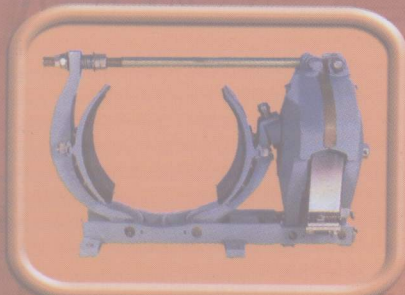

D.C. ELECTRO - MAGNETIC BRAKE



BRAKE DRUM COUPLING



FLEXIBLE GEARED COUPLING



RADIO REMOTE CONTROL



SHROUDED DSL



CURRENT COLLECTORS

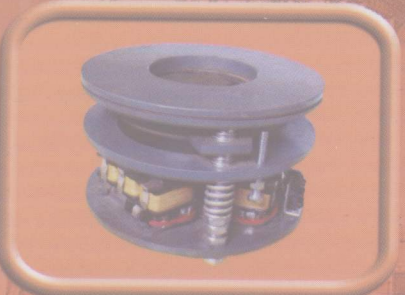

DISC BRAKE



SNATCH BLOCK



RAIL CLAMPS



FLEXIBLE TRAILING CABLE

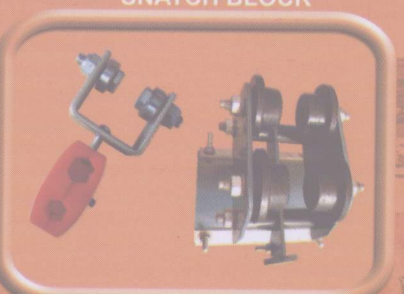

CABLE TROLLEYS



CABLE REELING DRUM

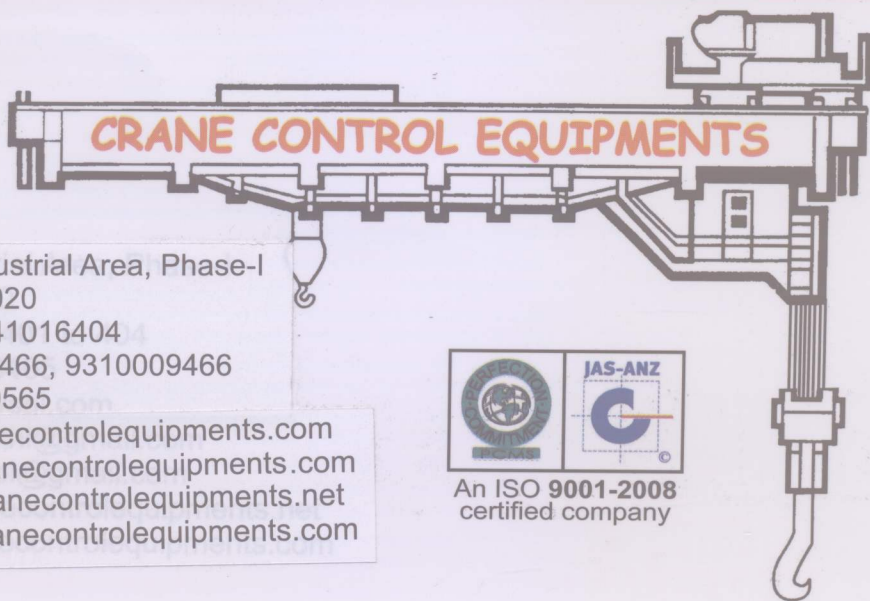

Works :

B-249, Okhla Industrial Area, Phase-I
New Delhi - 110 020
Ph. : 41016403, 41016404
Mobile : 9810009466, 9310009466
E-Mail : info@cranecontrolequipments.com

sales@cranecontrolequipments.com
website : www.cranecontrolequipments.net
www.cranecontrolequipments.com



An ISO 9001-2008
certified company