

ISO 9001 : 2015 CERTIFIED

NilpackTM

NILACHAL AUTOMATION AND TECHNOLOGIES PVT. LTD.



25

Years of glory



**WE DO WHAT WE SAY
WE SAY WHAT WE DO...**

Vedant Patil - Founder Director

☎ : +91 8956401475, 9922878206

✉ Email: v.patil@nilachalautomation.com

Engineering the Future of Packaging & Automation!

Precision Packaging Machinery | Industrial Automation

| Turnkey Solutions for food processing & packaging automation | R&D

| Machine Upgrades | 24/7 Support | Spares

| Custom Engineering & Process Optimization



COMPANY PROFILE

WE DO WHAT WE SAY
WE SAY WHAT WE DO...

About Us:

Nilachal Automation and Technologies Pvt. Ltd. (NATPL), established in 2021, is a leading name in the automation and packaging machinery industry. Under the leadership of Mr. Vedant Nathu Patil (Founder Director) and Mr. Narayan Homi Commissariat (Managing Director), NATPL has quickly gained recognition for its innovative and reliable solutions. The company is a sister concern of Narayan Lambodar & Behera Associates (NLBA), which has been a trusted player in the packaging sector since 2002.

Mr. Vedant Patil, the Founder Director, brings years of engineering expertise and a passion for technological advancement to NATPL. His leadership has driven the company to continually innovate, ensuring our products meet the highest standards of quality and performance.

With over 20 years in manufacturing, we've produced 1,000+ packaging machines, serving industries like snacks, spices, food grains, chemicals, and pharmaceuticals. Our flagship brand, "NILPACK", including models like NILPACKSMART-450, NILPACK-NANO-550, and NILPACK-MULTI-750, is synonymous with quality and innovation. At NATPL, we are dedicated to delivering superior, competitively priced solutions that boost productivity and efficiency.



Our Presence:

Headquartered in Pune, India, NATPL has an extensive sales and service network across the country and internationally, ensuring prompt support and customer satisfaction.

WE DO WHAT WE SAY
WE SAY WHAT WE DO...

Our Expertise:

NATPL is a fast-emerging leader in industrial automation and packaging solutions. With a dynamic team of engineers and extensive shop-floor experience, we provide cutting-edge engineering and automation solutions for industries including:

FMCG

Our packaging solutions cater to a wide range of fast-moving consumer goods, ensuring high-speed, precision-based packaging that enhances product shelf life and market appeal. From snacks and confectionery to personal care and household products, we provide efficient packaging machinery that meets industry standards for hygiene and safety.

Food & Beverages

We offer specialized packaging solutions designed for food safety, preservation, and convenience. Our machinery is ideal for handling dry and liquid food products, including grains, spices, dairy items, ready-to-eat meals, and beverages. With advanced sealing and filling technologies, our machines ensure minimal waste and extended freshness.

Pharmaceuticals

Our pharmaceutical-grade packaging machines adhere to stringent quality and compliance standards. We provide solutions for blister packing, bottle filling, sachet packaging, and strip packing of tablets, capsules, powders, and liquids. Our machines are designed to maintain product integrity and meet Good Manufacturing Practices (GMP) and FDA guidelines.

Dairy Products

We specialize in automated solutions for milk, cheese, yogurt, butter, and other dairy products. Our packaging machines ensure contamination-free, high-speed production with advanced sealing and labeling technologies. By maintaining strict hygiene standards, we help dairy manufacturers enhance productivity and ensure product safety.

Our mission is to foster long-term relationships by delivering reliable, high-performance, and cost-effective packaging solutions while maintaining world-class standards. Through continuous research and development, we design and manufacture low-maintenance, performance-driven machines tailored to market demands.

WE DO WHAT WE SAY
WE SAY WHAT WE DO...

Our Leadership Team

MR. NARAYAN HOMI COMMISSARIAT

Managing Director



As Managing Director, Mr. Narayan Homi Commissariat leads management, product innovation, and market strategies. A natural innovator, he has driven year-on-year growth at Nilachal Automation and Technologies Pvt. Ltd. (NATPL) in the mechanical and manufacturing sectors. With 24 years of experience in mechanical technology, he has played a key role in delivering cutting-edge solutions. Prior to co-founding NATPL, he was with Narayan Lambodar Behera and Associates, where he designed and implemented packaging machines, secondary packaging systems, Eco-Dills, and compressors.

MR. VEDANT PATIL

Founder Director



Mr. Vedant Patil, Founder Director of NATPL, leads operations and administration, product innovation, business promotion, and market strategies at the company. With 18 years of experience in information technology, human resource management, and system implementation, including SAP/ERP/Cloud 9, he has played a key role in automating mechatronics-based packaging solutions. Prior to joining NATPL, he was associated with OTIF Components Pvt. Ltd., where he established an automotive components forging plant and managed operations and HR systems. Additionally, he contributed to the establishment of a packaging machine manufacturing setup in India and abroad, including a robust sales and service support network.

MR. CHARAN COMMISSARIAT

Director



Mr. Charan Commissariat oversees factory management, product innovation, and manufacturing operations at NATPL. A technical expert in machine building, assembly, and product development, he has driven technological advancements in packaging machine production and other engineering applications. With 18 years of experience in packaging machinery and assembly, he has significantly contributed to the company's growth and technological excellence. Homi Sir's guidance and inspiration have been the backbone of this journey.

WE DO WHAT WE SAY
WE SAY WHAT WE DO...

Our Leadership Team

MR. NITISH SAHU

Assistant Manager, Design



A creative and detail-oriented design professional, Mr. Nitish Sahu brings a keen sensibility for shapes, textures, and functionality to NATPL's product development. His expertise lies in designing and prototyping products that align seamlessly with manufacturing processes. With experience in both manual and fully automated machine designs, he ensures a perfect balance between creativity, efficiency, and technical excellence in every project.

MR. NARESH BORSE

Manager, Customer Service Support



Mr. Naresh Borse is responsible for delivering end-to-end customer solutions, ensuring seamless Final Acceptance Testing (FAT) in the presence of clients. With 15 years of versatile experience in the packaging domain, he gathers valuable customer feedback and collaborates with design teams to implement proven solutions. His expertise spans primary, secondary, and liquid packaging, including erection, commissioning, and field support.

MR. KISHOR PATIL

Marketing Executive



Kishor Patil holds a degree in Computer Engineering and serves as a Marketing Executive at Nilachal Automation and Technologies Pvt. Ltd., based in Pune, Maharashtra. He is responsible for managing both pre-sales and post-sales activities, including preparing essential documents and coordinating follow-ups. Additionally, Kishor oversees various administrative tasks and plays a pivotal role in ensuring customer satisfaction through consistent support and service.

"It is with great sadness that we announce the passing of Mr. Homi Commissariat in November 2023. As our visionary Executive Chairman, he provided 58 years of leadership, and his legacy continues to inspire us. At NATPL, our leadership team's expertise and commitment drive innovation, efficiency, and customer satisfaction across all our engineering and automation solutions."

WE DO WHAT WE SAY
WE SAY WHAT WE DO...

Our Products - The NILPACK Series:

We take pride in our innovative brand "NILPACK", known for its superior-quality packaging machines, including:

Nilpack - MULTI 750 WITH 10 HEAD WEIGH FILLER

VFFS pouch packaging with multihead weigher

The NILPACK Series offers advanced VFFS pouch packaging integrated with a Multihead Weigher for precise, high-speed weighing and efficient, reliable packaging across various industries.

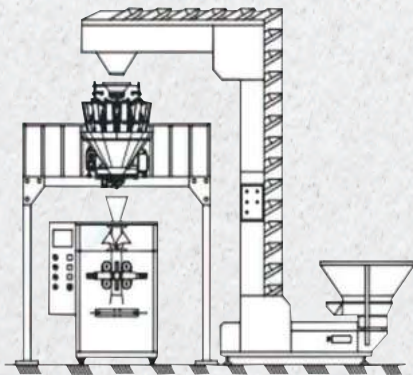

FEATURES

- 1) Z Shape Conveyor
- 2) Material Drop Hopper
- 3) Multi Head Weigher
- 4) Side Guard Of Stand
- 5) Multi Head Hmi Screen
- 6) Collar Chute
- 7) Fabricated Stand
- 8) Pulling Assembly
- 9) Electrical Control Panel
- 10) Inlet Conveyor Hopper
- 11) Ladder

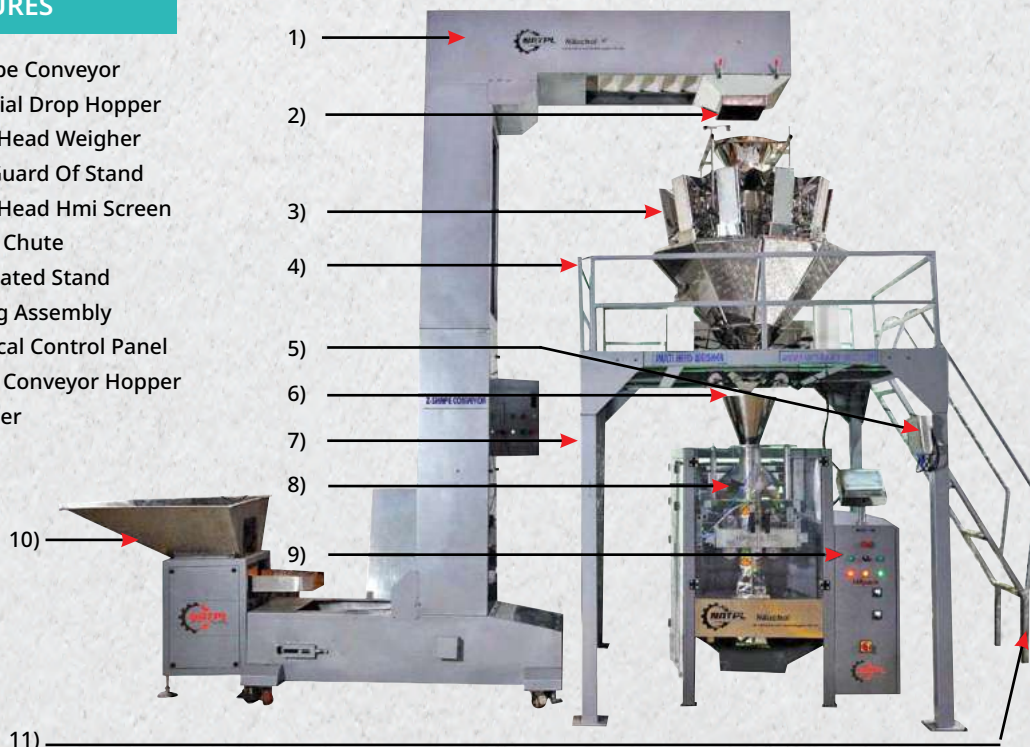

WE DO WHAT WE SAY
WE SAY WHAT WE DO...

Our Products - The NILPACK Series:

Nilpack SMART-450

A high-speed, compact machine for small to medium-scale production, ensuring precise, consistent packaging with minimal waste.

TECHNICAL SPECIFICATION

OPERATION	SERVO	PNEUMATIC
Controlled	-	PLC Controlled
Output	-	60ppm To 80 Ppm.
Filling Range	-	1gram 100gram
Minimum Bag Width	-	100mm
Maximum Bag Width	-	300mm
Maximum Bag Height	-	165mm
Packaging Material	-	Laminated/Virgin Film.



Nilpack NANO-550

An advanced packaging system optimized for high-volume production, with intelligent automation to maximize efficiency and minimize downtime.

TECHNICAL SPECIFICATION

OPERATION	SERVO	PNEUMATIC
Controlled	Motion Controlled	PLC Controlled Ranging
Output	Ranging Upto 80 PPM.	Upto 60 PPM.
Filling Range	1gram 100gram	1gram 100gram
Minimum Bag Width	30mm	30mm
Maximum Bag Width	100mm	100mm
Maximum Bag Height	165mm	165mm
Packaging Material	Laminated/Virgin Film	Laminated/Virgin Film.



Nilpack ECHO 650, With 2 Head linear weigh Filler

A robust, multi-functional machine designed for diverse packaging needs, offering excellent adaptability for various industries.

TECHNICAL SPECIFICATION

OPERATION	SERVO	PNEUMATIC
Controlled	Motion Controlled	PLC Controlled
Output	Ranging Upto 80 Ppm.	Ranging Upto 60 Ppm.
Filling Range	1gram 100gram	10gram 200gram
Minimum Bag Width	30mm	120mm
Maximum Bag Width	100mm	300mm
Maximum Bag Height	180mm	235mm
Packaging Material	Laminated/Virgin Film	Laminated/Virgin Film.

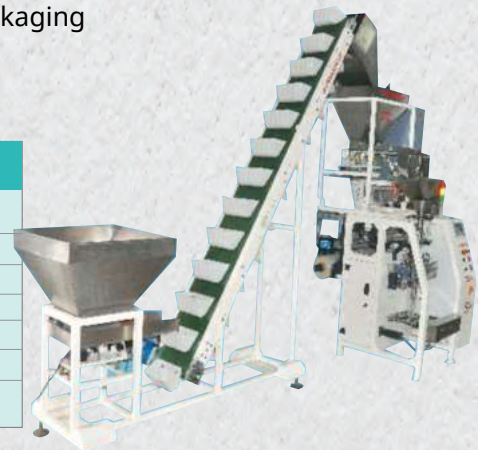

WE DO WHAT WE SAY
WE SAY WHAT WE DO...

Our Products - The NILPACK Series:

Nilpack MULTI-750

A versatile, fully automated system designed to handle multiple packaging formats with high accuracy and precision.

TECHNICAL SPECIFICATION

OPERATION	SERVO	PNEUMATIC
Controlled Output	Cpu Motion Controlled Ranging Upto 120 Ppm.	PLC Controlled Ranging Upto 75 Ppm.
Filling Range	100gram 1kg.	100gram Kg.
Minimum Bag Width	50mm	220mm
Maximum Bag Width	210mm	480mm
Maximum Bag Height	320mm	320mm
Packaging Material	Laminated/Virgin Film	Laminated/Virgin Film



Nilpack GIANT 950

An industrial-grade machine capable of handling large-scale packaging operations with advanced control systems for optimal performance.

TECHNICAL SPECIFICATION

OPERATION	SERVO	PNEUMATIC
Controlled Output	Cpu Motion Controlled Ranging Upto 70 Ppm.	PLC Controlled Ranging Upto 50 Ppm.
Filling Range	500gram 2kg.	500gram 2kg.
Minimum Bag Width	50mm	280mm
Maximum Bag Width	300mm	650mm
Maximum Bag Height	410mm	410mm
Packaging Material	Laminated/Virgin Film	Laminated/Virgin Film

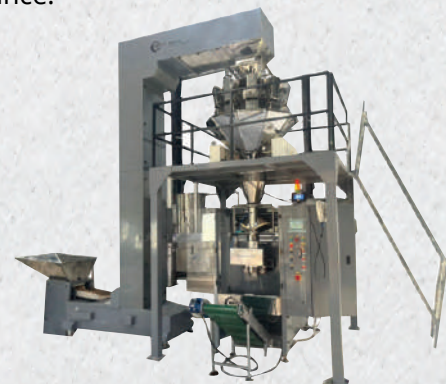

Nilpack GRAND 1250

A flagship model with the latest automation technology, ensuring seamless integration into high-speed production while maintaining quality.

TECHNICAL SPECIFICATION

OPERATION	SERVO	PNEUMATIC
Controlled Output	Cpu Motion Controlled Ranging Upto 30 Ppm.	PLC Controlled Ranging Upto 15 Ppm.
Filling Range	5kg 10kg.	5kg To 10kg
Minimum Bag Width	220mm	400mm
Maximum Bag Width	420mm	900mm
Maximum Bag Height	530mm	530mm
Packaging Material	Laminated/Virgin Film	Laminated/Virgin Film



WE DO WHAT WE SAY
WE SAY WHAT WE DO...

Our Products - The NILPACK Series:

Jar filling line single track machine with auger filler for powder packing

Technical Specifications	Single Track Line	Double Track Line
Output Speed	Up to 40-50 Jar/Min	Up to 90-100 Jar/Min
Operation	PLC Motion, VFD, Sensor Controlled Operation with 7" HMI Screen	
Conveyor Belt Type	Plastic Slat Belt	Plastic Slat Belt
Connected Load	3kw	4kw
Compressed Air	6CFM at 9BAR	6CFM at 9BAR

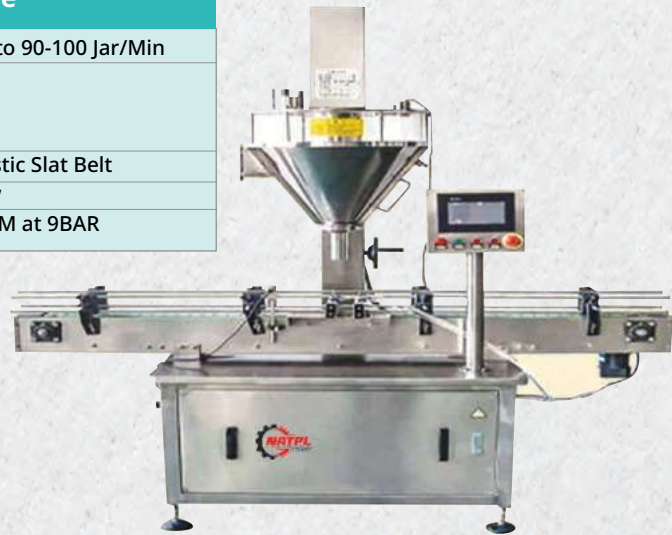

Jar filling line double track machine with auger filler for powder packing

SUITABLE PRODUCTS

Chocolates, candy, pharma tablets, powders, spices, herbal products, protein powder, paste, ghee, sauce, and many more...



FEATURES & BENEFITS

- PLC controlled with modular construction | Compatible with filling, capping, closing, and crowning.
- | Inner/outer capping units | Supports various fillers (Multihead, Auger, Cup, Piston)
- | Optional automatic labeling systems | Online batch coding device
- | Flexible to accommodate various container sizes and shapes.

WE DO WHAT WE SAY
WE SAY WHAT WE DO...

Our Products - The NILPACK Series:

LINER WEIGH FILLERS

Vertical Form Fill Seal Machine - Technical Specifications and Applications

Single Head Linear Weigher

TECHNICAL SPECIFICATION	
Machine Type	Semi Automatic
Brand	Nilpack Packaging Solutions
Capacity	10gm To 100gm. And 200gm To 500gm
Material	Ready Pouches
Operation	Semi-Automatic & Fully Automatic



Two Head Linear Weigher

TECHNICAL SPECIFICATION	
Machine Type	Semi Automatic
Brand	Nilpack Packaging Solutions
Capacity	100gm To 1Kg
Material	Ready Pouches
Operation	Semi-Automatic & Fully Automatic



Two Head Linear Weigher

TECHNICAL SPECIFICATION	
Machine Type	Semi Automatic
Brand	Nilpack Packaging Solutions
Capacity	100gm To 1Kg
Material	Ready Pouches
Operation	Semi-Automatic & Fully Automatic



Suitable For:

The Linear Weigh Filler is best suited for grocery products, pulses, snacks, namkeen, chips, fryums, grains, sugar, whole spices, chocolate, candy, rice, etc.



WE DO WHAT WE SAY
WE SAY WHAT WE DO...

Our Products - The NILPACK Series:

SUITABLE FILLERS

Auger Filler

Suitable for Powders
Such as flours, wheat, milk powder, pharmaceutical powders, ground spices, herbal powders, and all types of fine powders, etc.



Cup Filler

Suitable for all kinds of spices, small granules, coffee, beans, etc.



Weight Filler

Suitable for extruded snacks, potato chips, namkeen, dry fruits, tea, frozen foods, etc.



Piston Filler

Suitable for ketchup, sauces, peanut butter, semi-solids, and thick pastes.



Nilpack Horizontal Flow Wrap

- **Minimum Order Quantity:** 1 Piece
 - **Brand:** NILPACK Packaging System
 - **Model Number:** HFW-150
 - **Sealing Type:** Center Seal
 - **Usage/Application:** Food Packaging
 - **Speed:** 80 to 100 pouches per minute
 - **Voltage:** 420V, 50Hz, 3-Phase
- Horizontal Flow Wrap Machine - Model HFW-150
Suitable for packing chikki, soap, trays, cakes, biscuits, bread, toast, bun pav, cookies, jaggery, etc., in pillow pouches.
- **Additional Information:**
Delivery Time: 1 month



TECHNICAL SPECIFICATION

Machine Output:	Ranging from 70 PPM to 100 PPM
Filling Range:	10 grams to 5 kg
Product to be Filled:	Free-flowing and non-free-flowing materials (all powders, granules, namkeen, tea, and coffee beans)
Minimum Bag Width:	100 mm
Maximum Bag Width:	600 mm
Maximum Bag Height:	480 mm
Connected Load:	8 kW

WE DO WHAT WE SAY
WE SAY WHAT WE DO...

Our Products - The NILPACK Series:

Nilpack Z SHAPED BUCKET CONVEYOR

TECHNICAL SPECIFICATION

No Of Machines To Be Feed-01 To 4 Nos According To Requirement.

Bucket Size	130mm X 400mm
Bucket Capacity	1.8 Liter, 2.1 Liter
Conveyor Height	According To Requirement
Drop Height	300mm Below From Conveyor Height
Out Put	45 To 50 Bucket Per Min.
Bucket Material	Moulded Food Graded Pp.
Material Feeding	Through Vibratory Feeder Controlled By Bucket And Level Sensor.
Bucket Reliever	Pneumatic Bucket Reliever For Each Packing Machine Controlled By Level Sensor And Controller
Conveyor Chain	From Packing Machine.
Structure	En- 42 Links & Nylon
Contact Parts	Rollers (MS / SS)
Motor	Ms Powder Coated
Sprocket	SS 304 & 316 1.5hp, 3 Hp, Geared Motor.

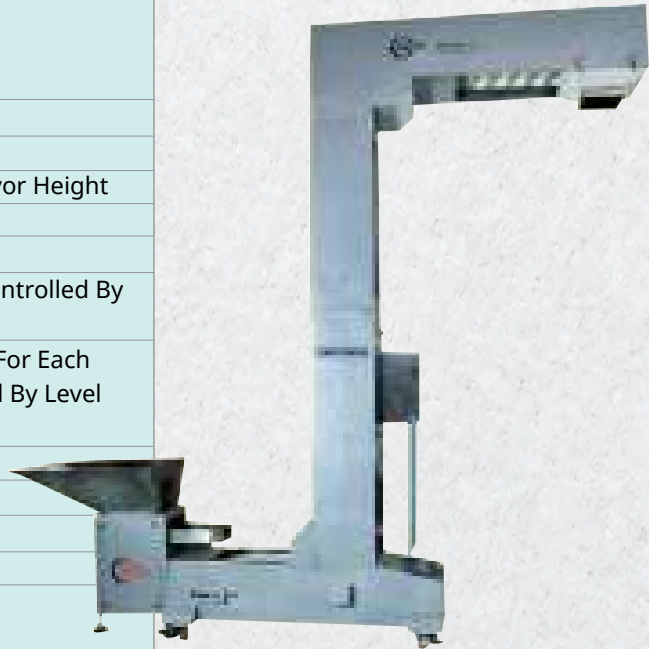

Nilpack INCLINED SCREW CONVEYOR

TECHNICAL SPECIFICATION

Hopper Capacity	150 To 250 Liter
Drop Height	According To Requirement
Output Volume Per	500kg/min
Rpm	SS304
Contact Parts	Ms Powder Coated Or SS As
Structure	Per the requirement.
Height Adjustment	50-75 mm Through Foot
Motor	1.5 Hp, 3hp, 50hz, 2 Nos (including Sterror Motor)
Sterror Will Be Provided At Bottom To Push The Material To Screw	



WE DO WHAT WE SAY
WE SAY WHAT WE DO...

Our Products - The NILPACK Series:

CONVEYORS

Nilpack BELT CONVEYOR

TECHNICAL SPECIFICATION	
Belt Material	PVC
Usage/Application	Transfer the material
Design Type	Horizontal
Type	Flat Belt Conveyor
Structure	MS powder coated
Brand	NILPACK Packaging Systems
Size	Customize
Material	Stainless Steel
Condition	New



It is used for transfer the pouches, box, material, etc.

Nilpack ACCLIVITIOUS CONVEYOR

TECHNICAL SPECIFICATION	
Type	Slat Belt Conveyor
Brand	NILPACK Packaging Systems
Usage/Application	Transfer pouches
Structure	Food grade & MS
Length	1-10 feet
Capacity	1 to 50 (kg/feet)
Material	Nylon
Surface	Polished



Nilpack POUCH TAKE OF CONVEYOR

The pouch take-off conveyor is suitable for transferring the pouches from the packaging machine to secondary packaging.

TECHNICAL SPECIFICATION	
Type	Flexible Conveyors
Brand	NILPACK Packaging Systems
Usage/Application	Transfer pouches
Structure	Food grade & MS
Length	1-10 feet
Material	Aluminium
Surface	Polished



WE DO WHAT WE SAY
WE SAY WHAT WE DO...

Our Products - The NILPACK Series:

Nilpack POUCH TAKE OF CONVEYOR

TECHNICAL SPECIFICATION

Conveyor Type	Flat Belt Conveyor
Belt Width	200mm-400mm
Belt Type	Flat Belt With Cleats (cleat Height 10mm to 20mm)
Conveyor Speed	10 To 12 Mm Per Min.
Speed Control	Through Vfd
Conveyor Length	2 Meter
Inclination Angle	15 Deg To 60deg.
Structure	Ms Powder Coated Or Ss (according To Customer Requirement)
Motor	0.5 Hp Geared Motor

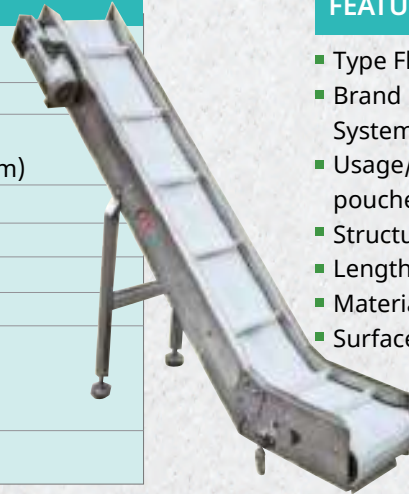

FEATURES

- Type Flexible Conveyors
- Brand NILPACK Packaging Systems
- Usage/Application Transfer pouches
- Structure Food grade & MS
- Length 1-10 feet
- Material Aluminium
- Surface Polished

The pouch take-off conveyor is suitable for transferring the pouches from the packaging machine to secondary packaging.

Nilpack RIBBON BLENDER

The blender is designed for mixing two or more products. It is best suited for mixing spice powders, instant mixes, milk powder, chili powder, pharmaceutical powders, colors, vitamin powders, and any fine powders, etc.

TECHNICAL SPECIFICATION

Brand	NILPACK Packaging Systems
Material	Powder
Usage/Application	Powder mixing
Shape	U shape
Design Type	Customized
Phase	3 Ph
Automation Grade	Automatic



FEATURES

- Very fast operation
- Low power consumption
- Easy access for cleaning
- High productivity
- Low maintenance

THERMAL TRANSFER OVERPRINTER HIGH QUALITY BATCH CODE PRINTING ON LAMINATE

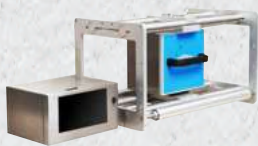

Thermal transfer technology utilizes a thermal printer consisting of individual ceramic resistors that are selectively heated to transfer the desired image from a coated ribbon directly onto the substrate.



- Batch Coding Device (Hot Foil Coder)
- Mini Tto (Thermal Transfer Overprint)
- Compact Tto (Thermal Transfer Overprint)
- Material laminate
- Usage/Application printing Automation
- Grade Automatic
- Ink Colour black
- Weight 5kg

The TTO is a preferred option for delivering high-quality codes, including date, price, batch, linear & data matrix barcodes, logos, graphics, etc., across the food and pharmaceutical industries, including snack foods, bakery products, and packaged foods.

The TTO printer can be easily integrated into a wide range of vertical and horizontal form-fill-seal packaging and labeling lines. It is also suitable for printing on flexible packaging and labels.

WE DO WHAT WE SAY
WE SAY WHAT WE DO...

Our Products - The NILPACK Series:

TURMERIC / CHILLI / MASALA / ATTA PROCESSING PLANT

MACHINE SPECIFICATION

Main machine with fabricated foundation, AVM pad, dust collector filter cloth bags, dust collector frame, motor railing, motor pulley, V-belt, nuts, bolts, and putin as per our standard fitting.

Grinding Setup for Chilli Processing



Pulvilizer With Dust Collectar



Rotary Airlock Valve



Vibro Shifter



SCOPE OF SUPPLY

Equipment: Gyro Vibratory Sieve Separator Model Fgs-1500 Of 1500 Mm (4 Feet) Diameter Single Deck Arrangement With Required Mesh Screens And Accessories Like Oversize And Undersize Outlets, Mesh Framework, Quick Release Clamps, Etc. All Product Contact Parts Will Be Made From Stainless Steel Ss-304 Grade And Others From Ss As Per Our Standard Supply.
Electrical Motor: Special Vibratory Motor Of 3 H.p.

MACHINE SPECIFICATION

Equipment	Gyro Vibratory Sieve Separator
Model	Fgs-1500
Number Of Decks	Single
Diameter Of Sieve	1500 Mm (3 Feet)
Sieve Size	As Per Requirement (Like 1mm, 1.5mm, 2mm, Etc)
Type Of Motor Drive	Direct
H.p. Of Motor	3 H.p.
Mode Of Feeding	Through Rotary Air Lock Valve
Mode Of Collection	Manual
Material Of Construction:	All Contact Parts In Stainless Steel Ss-304 & Others In Ms

WE DO WHAT WE SAY
WE SAY WHAT WE DO...

Machine Spare Parts

Nilpack ECHO 650 AUGAR FILLER WITH SCREW FEEDER



Product To Be Packed:

Masala Powder / Turmeric / Chilli Powder



Quantity To Be Packed:

50g – 1kg

FEATURES

- PLC Control
- Low power consumption
- Easy to use
- Low maintenance
- Space-saving design
- High weight accuracy

Impact Pulverizer



MACHINE SPECIFICATION

Equipment	Pneumatic Conveying System Pcs-500
Model	As Per Design
Conveying Distance	Cy-500
Cyclone Model	In Ss304.
Material Of Construction: Stainless Steel Ss-304 Grade & Non-Contact Parts In Ss304.	

SCOPE OF SUPPLY

Equipment: "Fine" Pneumatic Conveying Model Pcs-500 With Sets Of Pipes, Bends, Flanges Before The Cyclone Made From Stainless Steel Ss-304 & After The Cyclone, Cyclone Header Etc. All Made From Steel As Per Our Standard Supply.

WE DO WHAT WE SAY
WE SAY WHAT WE DO...

Extra Service:

We provide a wide range of machinery solutions tailored to customer requirements. If you have any specific needs, please let us know—we'll help you find the right solution.

Single Nozzle 6 In 1 Machine

TECHNICAL SPECIFICATION	
Production	7-8kg/Hour
Supply 230v Single	230v Single Phase
Power	0.5hp
Size	2.5x2x2 (Feet)
Weight	40kg
Material Steel	Stainless Steel (Ss304)
Warranty	1 Year



Three Nozzle Machine

TECHNICAL SPECIFICATION	
Production	14-15kg/hour
Supply	230v Single Phase
Power	0.5hp
Size	2.5x2x2 (Feet)
Weight	45kg
Material steel	Stainless steel (SS304)
Warranty	1 YEAR



Four Nozzle Machine

TECHNICAL SPECIFICATION	
Production	20-25kg/hour
Supply	230v Single Phase
Power	1hp
Size	2.5x2x2.5 (Feet)
Weight	75kg
Material steel	Stainless steel (SS304)
Warranty	1 YEAR



Papad Machine

TECHNICAL SPECIFICATION	
Specificatins	UPM1
Capacity	2-3 KG/Hr
Machine Size	(4x2x3) Feet
Motor (Crompton Greaves)	1HP
Papad size	6" & 8" (inch)
Unit per Hr	1 Unit
Labour Required	1 or 2
Attached eith Sheet Maker	



Papad Machine

TECHNICAL SPECIFICATION	
Specificatins	UPM2
Capacity	4-5 KG/Hr
Machine Size	(6x2x3) Feet
Motor (Crompton Greaves)	0.25+1HP
Papad size	6" & 8" (inch)
Unit per Hr	1 Unit
Labour Required	1 or 2
With Machine	Ata Mixing/ Sheeter Machine

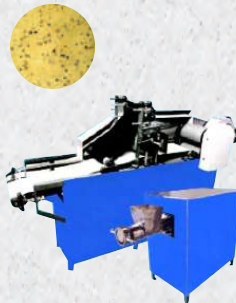

Papad Machine

TECHNICAL SPECIFICATION	
Specificatins	UPM3
Capacity	8-10 KG/Hr
Machine Size	(9x2x4) Feet
Motor (Crompton Greaves)	0.5+1.5HP(CG)
Papad size	6" & 8" (inch)
Unit per Hr	1 Unit
Labour Required	2 or 3
With Machine	Ata Mixing/ Sheeter Machine

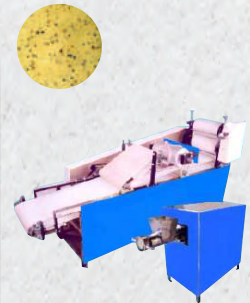

Papad Dryer Machine

TECHNICAL SPECIFICATION		
	Small	Large
Size	6x2x2.5	12x2.5x3
Mothor HP	0.25 HP	0.5+0.5
Hitting Coil - (kw)	1-3 Nos	1-10Nos
Conveyor belt	3Nos	7Nos
Power Unit	1.5 to 2	3 to 4
Power Supply	1 Phase	3 Phase

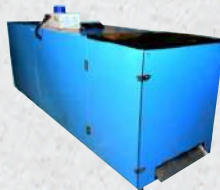

Atta Mixing Machine

TECHNICAL SPECIFICATION				
Capacity (kg)	5	10	15	20
Motor HP	0.5	1.0	1	1
Weight (kg)	43	100	110	119

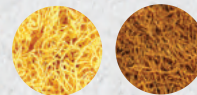

WE DO WHAT WE SAY
WE SAY WHAT WE DO...

Khichiya Machine

TECHNICAL SPECIFICATION				
Capacity (kg)	10	15	20	30
Motor HP	1	1	1.5	2
Weight (kg)	105	110	115	125



Banana Chips

TECHNICAL SPECIFICATION	
Size	35x13x25
Motor HP	1HP
Weight (kg)	40 (kg)
Capacity	200 to 250 (kg)
Power Supply	1Phase
Die: 3 (Round Capsule Belt)	



Domestic / Commercial Floor Mill

TECHNICAL SPECIFICATION			
Model	1.5 Hp	2Hp	3Hp
Capacity (kg)	12	20	35
Unit	1	1.75	2.2



Khawa / Roasting Machine

TECHNICAL SPECIFICATION				
Capacity (kg)	30	60	120	200
Motor HP	0.25	0.5	0.5	1
Weight (kg)	20	40	80	150



Also Available Capacity in 250, 500 (kg)

Frasan Machine

TECHNICAL SPECIFICATION		
Drum Size	7 Inch	9 Inch
Motor	0.5	1
Weight	55	80
Jali	9	9
Size (Inch)	40x11x35	45x14x38



Other Machine Available

- Chakli Machine
- Pulveriser Machine
- Floor Mill Domestic & Commercial
- Pani Puri Machine



WE DO WHAT WE SAY
WE SAY WHAT WE DO...

In House Facilities:

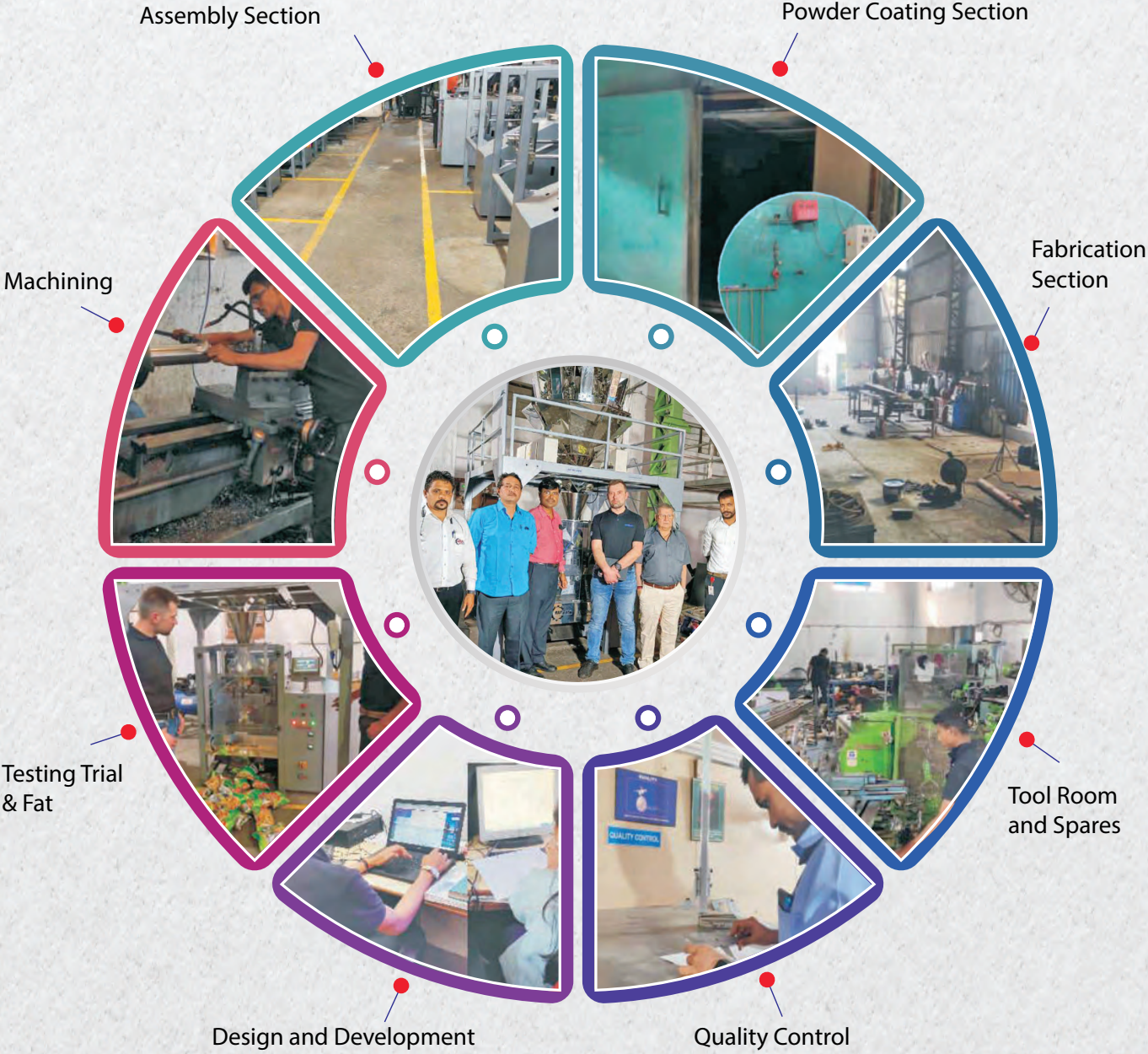

At NATPL, we take pride in our state-of-the-art in-house facilities, ensuring end-to-end manufacturing excellence. Our capabilities include **Assembly** for seamless product integration, **Powder Coating** for durable surface finishing, **Fabrication** for precision metalwork, **Tool Room & Spares** for essential components, and **Delegacy Visit** provisions for audits and approvals. We maintain strict **Quality Control**, drive innovation through **Design & Development**, conduct rigorous **Testing & Trial**, and ensure precision with **FAT Machining**. These facilities enable us to deliver high-quality, reliable solutions to our customers.

WE DO WHAT WE SAY
WE SAY WHAT WE DO...

Machine Spare Parts



Suitable for Packaging Machines

- Gears
- All Types & Sizes of Cutters & Blades
- For Packaging
- Gears & Sprockets
- All Types of Heaters and Cables
- Sensors (Proximity Sensor / Inductive Sensor / Reflective Sensor)
- All Types of Set Collars
- Auger Screws and Screw Pipes
- Timing Belts
- Cutter Assembly with Sealing Unit
- Analog Sensor
- Sealer



Machine Pneumatic spare parts

SUITABLE FOR PACKAGING MACHINE

- Pneumatic Cylinder – Make (Festo / SMC)
- Push Fit Pneumatic Connector
- Pneumatic Regulator
- Pneumatic Solenoid Valve (Make Festo / SMC)
- Magnetic Sensor (Read Switch)
- PLC's Siemens / Schneider / Mitsubishi / Trio
- I/O Card for PLC / HMI Siemens / Schneider / Mitsubishi / Trio
- VFD Siemens / Schneider / Mitsubishi / Danfoss / Trio
- Etc Switch gear
- Motor & Gear box



WE DO WHAT WE SAY
WE SAY WHAT WE DO...

Our Esteemed Clients:



Corporate Social Responsibility (CSR) at NATPL

At NATPL, our CSR efforts focus on sustainability, community development, and ethical business practices:

Environmental Sustainability:	Community Support:	Employee Well-Being
<p>We prioritize eco-friendly practices, energy efficiency, and waste reduction in all operations.</p> 	<p>We invest in local education, healthcare, and skill development programs to empower individuals and improve quality of life.</p> 	<p>We ensure a safe work environment, offer professional growth opportunities, and provide fair compensation for our team.</p> 

Together, we are committed to building a better and more sustainable future.

Client Testimonials

"NATPL's precision engineering and commitment to quality have exceeded our expectations. Reliable products and excellent service!"

Sudarshan Gawali
True Elements

"From design to final execution, NATPL delivers excellence at every stage. A trusted partner for our automation needs!"

Sachin Memane
Pushkaraj Foods Pvt Ltd

ISO 9001 : 2015 CERTIFIED

NilpackTM

JOIN US ON OUR JOURNEY
AS WE PAVE THE WAY FOR A FUTURE FILLED
WITH SUCCESS AND PROSPERITY

NILACHAL AUTOMATION AND TECHNOLOGIES PVT. LTD.

25

Years of glory

WE DO WHAT WE SAY
WE SAY WHAT WE DO...

NILACHAL AUTOMATION AND TECHNOLOGIES PVT. LTD.



Head Office:

Gat No. 813, Pawar Wasti, Rasta No. 10,
Kudalwadi, Chikhali,
Pune - 412114, Maharashtra, INDIA.

Website: www.nilachalautomation.com

Contact Numbers:

+91 8956401475 / 76 | +91 9922878206

Email:

General Inquiries: info@nilachalautomation.com

Sales: sales@nilachalautomation.com

Operations: operationhead@nilachalautomation.com

Management: v.patil@nilachalautomation.com,
narayan@nilachalautomation.com

Customer Service Support:

Contact: +91 8956401476

Email: service@nilachalautomation.com

Branch Offices

Dubai: Industrial Area 5, Al Qusais, Dubai, UAE. ☎ +91 9156379998 / +91 8956401475

Mumbai: Commissariat Bldg., 231, Dr. D. N. Road, Mumbai - 400001. ☎ +91 8956401475 / 76 | +91 9922878206

Bihar: Bhawana Nand Mishra, Pratap Nagar, Madhubani, Purnea, Bihar - 854301. ☎ +91 8969441956

Madhya Pradesh: Sagar Patil, Flat No. 104, Shivansh Shankar Bag, Marimata Chowk, Police Line, Indore. ☎ +91 8956401477

Odisha: NIKP Group, B/39, Chandaka Industrial Estate,

Patia, Next to ODM Business School, PIN - 751024. ☎ +91 9922878206 / +91 8956401475