

EDM cutting parts service provider



# THAKUR JI MACHINE AND TOOLS

Enterprise and product introduction

☎ +91 9970014420 / 7970649340 / 7494072377

✉ [thakurjimachineandtools@gmail.com](mailto:thakurjimachineandtools@gmail.com)

🌐 [www.thakurjimachinetools.com](http://www.thakurjimachinetools.com)

## CONTENTS



1

**Enterprise profile**

2

**Product introduction**

3

**Production . sales**

4

**corporate culture**



# HONGLU Molybdenum wire



Product Name: Honglu molybdenum wire

Specification: 0.18mm, 2000m

Package : S Type, T5 Type, 0.18mm \* 2000m, 30 discs / Box (Carton Package)

Origin: Xiamen Honglu Tungsten Molybdenum Industry Co., Ltd

Is 09001, is 014001?, which is the first one in China?, ISO / TS

16949 triple certification enterprise





# JDC Molybdenum Wire



- Product Brand : JDC Brand
- Product Name: high efficiency wire cut molybdenum wire
- Product length: 2000 meters
- Product specification: 0.18mm
- Note: the storage environment of molybdenum wire should be free of acid-base harmful gas and phase





# Great Wall Molybdenum Wire



Product Name: cold drawn fixed length wire cut molybdenum wire

Specification: diameter 0.18mm

Length : 2000m-2400m

Origin : Great Wall Brand Zigong Cemented Carbide Co., Ltd

Package: vacuum plastic bag + carton

Suitable for cutting all kinds of die steel, hard alloy, copper, aluminum and other materials.

High tensile strength, and other similar products, strong corrosion resistance,

Long service life.



# Great Wall Molybdenum Wire

- The main characteristics of Great Wall molybdenum wire are as follows
- 1. "Great Wall" brand WEDM molybdenum wire is a kind of high strength product with rare earth elements.
- 2. Suitable for cutting all kinds of die steel, hard alloy, copper, aluminum and other materials.
- 3. High tensile strength, and other similar products, corrosion resistance, long service life.
- 4. The recommended working current is 2 ~ 2.5A.
- 5. The use effect is better when the new fillings are idled for 5-8 minutes.
- 6. It can be stored for a long time by vacuum packing. After opening, please pay attention to moisture and oxidation resistance.
- 7. Weight and length conversion formula:  $a = 8D * D$
- Where: a-weight of molybdenum wire per meter, unit: G
- D -- diameter of molybdenum wire, unit: mm.
- 8. The quality of this product has been approved by BSI and China Three Gorges Quality Assurance Center
- ISO 9001 / 2000 double certification.



# Diamond Molybdenum Wire



- Name: molybdenum wire for WEDM
- Brand : Blue Diamond / Black Diamond
- Specification: 0.18mm
- Length : 2000m-2400m





# Diamond Molybdenum Wire

- Diamond molybdenum wire has passed ISO9001 2000 quality system certification and obtained IQNet mark Certification
- Features of ultra high strength wire cut molybdenum wire:
- Molybdenum raw material is selected and manufactured by equipment and unique process.
- Ultra high strength (30-50% higher than GB / t4182-2003)
- It is not easy to break and has long service life.
- Small elongation, less tight wire, good stability, high cutting precision.
- It can increase high frequency power and improve rough machining efficiency.
- For example, it is better to cut after 5-10 minutes of idling before processing.
- Vacuum packaging is adopted to prevent oxidation and mildew, which can be stored for a long time



# XIANG Molybdenum Wire

## XIANG

### 香塔

HIGH EFFICIENCY EMD MOLYBDENUM WIRE

高效埃姆迪鉬絲

JAPANESE HIGH EFFICEIENCY EMD WIRE

日本高效率埃姆迪線材

- Name : High Efficiency EMD Molybdenum Wire
- Brand : Xiang
- Material : Moly Wire
- Specification : 0.18mm
- Length : 2000m
- Net Weight : 530g
- Gross Weight : 640g



# MIMY Molybdenum Wire



- Name : Premium Quality EDM Molybdenum Wire
- Brand : Mimy
- Specification : 0.18mm
- Length : 2000m





# JR3A Emulsion Paste

- usage method:
- Put emulsified paste (1kg) into 40-50 litres of tap water
- (do not use hard water such as well water and groundwater), which can be dissolved and used.
- This product has excellent cleaning effect
- Performance, suitable for high thickness,
- Large current (cutting current of ordinary machine tool > 3a, medium wire feeding machine tool > 5a) and medium wire feeding machine tool for multiple cutting,
- When replenishing liquid, please add paste and water in proportion.
- Our products are tested as harmless products (test report: bg-07nyqt-wt 010) WTO 10)





# JR3A Emulsion Paste

- matters needing attention:
- 1. Recommended parameters for high thickness cutting above 300mm: pulse width: 60-100,
- Duty cycle: 1:7-8,
- Cutting current: About 2.5A.
- Frequency conversion tracking speed shall be much slower than that of conventional cutting)
- 2. It is recommended to use a filter screen below grid 10 for medium wire cutting
- Cut continuously for about 100h and change the working fluid (water tank 40L)
- No pollution, environmental protection, no smell, harmless to the body
- The effect of medium wire feeding is better



# Wire Cut Copper Guide Wheel Assembly



- Guide wheel brand material: XieYe Cr12
- Tongzuo brand: XieYe
- Bearing brand: imported NMB
- Assembly method: pneumatic press





# Wire Cut Copper Guide Wheel Assembly

- Function of blade guide wheel
- In the work of the machine tool, the guide wheel will rotate with the molybdenum wire, and the molybdenum wire will rotate
- At the same time, the guide wheel rotates synchronously to form a fan like effect, which makes the fog work
- Liquid blow, fly, provide waterproof effect, waterproof performance upgrade, guide wheel
- After quenching treatment, Cr12 Steel material, durable!





# Wire Cut Copper Guide Wheel Assembly



THAKUR JI MACHINE AND TOOLS



# Wire Cut Copper Guide Wheel Assembly



THAKUR JI MACHINE AND TOOLS





# Cr12 Metal Single Side Guide Wheel



- Product Name: Cr12 metal single side guide wheel
- Material: Cr12 (Shanghai Baosteel)
- Product origin: Suzhou (factory direct sales)



# Cr12 Metal Single Side Guide Wheel



Outer Diameter 31.5/ Length 45/ Shaft 4

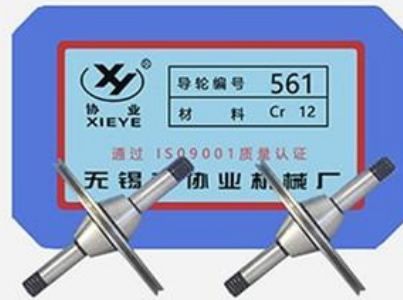

Outer Diameter 31.5/ Length 39 / Shaft 4



Outer Diameter 31.5/ Length 21/ Shaft 4



Outer Diameter 31.5/ Length 31/ Shaft 4



Outer Diameter 31.5/ Length 24/ Shaft 4



Outer Diameter 41.5/ Length 45 / Shaft 5



Outer Diameter 31.5/ Length 40/ Shaft 4



Outer Diameter 30 / Length 45/ Shaft 4

THAKUR JI MACHINE AND TOOLS



# Cr12 Metal Single Side Guide Wheel



Outer Diameter 30/ Length 34/ Shaft 5



Outer Diameter 41.5/ Length 46/ Shaft 5



Outer Diameter 40/ Length 51/ Shaft 5



Outer Diameter 35/ Length 40/ Shaft 5



Outer Diameter 37/ Length 46/ Shaft 5



Outer Diameter 37/ Length 46/ Shaft 4



Outer Diameter 35/ Length 52/ Shaft 4



Outer Diameter 32/ Length 40/ Shaft 4





# Cr12 Metal Single Side Guide Wheel



Outer Diameter 35/ Length 28/ Shaft 4



Outer Diameter 39/ Length 50/ Shaft 5



Outer Diameter 31.5/ Length 21/ Shaft 4



Outer Diameter 39/ Length 46/ Shaft 5



Outer Diameter 40/ Length 23/ Shaft 5



Outer Diameter 41.5/ Length 24/ Shaft 5



Outer Diameter 40/ Length 42/ Shaft 6



Outer Diameter 26/ Length 29/ Shaft 4

THAKUR JI MACHINE AND TOOLS





# Cr12 Metal Single Side Guide Wheel



Outer Diameter 31.5/ Length 50/ Shaft 4



Outer Diameter 41.5/ Length 44/ Shaft 5



Outer Diameter 37/ Length 54/ Shaft 5



Outer Diameter 30/ Length 26.5/ Shaft 4



Outer Diameter 30/ Length 45/ Shaft 5



Outer Diameter 40/ Length 31/ Shaft 5



Outer Diameter 31.5/ Length 35/ Shaft 4



Outer Diameter 31.5/ Length 30/ Shaft 4

THAKUR JI MACHINE AND TOOLS



# Cr12 Metal Single Side Guide Wheel



Outer Diameter 32.5/ Length 48/ Shaft 4



Outer Diameter 41.5/ Length 48/ Shaft 4



Outer Diameter 40/ Length 43/ Shaft 5



Outer Diameter 32/ Length 42/ Shaft 6



Outer Diameter 31.5/ Length 44/ Shaft 5



Outer Diameter 41.5/ Length 49/ Shaft 6



Outer Diameter 32/ Length 37/ Shaft 4



Outer Diameter 36/ Length 44/ Shaft 5

THAKUR JI MACHINE AND TOOLS



# EDM Tungsten Steel Conductive Block



- Product Name: wire cutting conductive block
- Material: alloy tungsten steel, YG8, YG3X
- Applicable equipment: EDM equipment
- Product application: high hardness, wear resistance, strength and toughness, corrosion resistance





# EDM Tungsten Steel Conductive Block

### Size Comparison Table

code	Specifications	L (mm)	D (mm)	H (mm)	ID (mm)
1721	12x12x12x6	12	12	12	6
1722	12x12x15x6	12	12	15	6
1723	14x14x14x8	14	14	14	8
1724	14x14x17x8	14	14	17	8
1725	16x16x12x8	16	16	12	8
1726	16x16x12x6	16	16	12	6
1727	16x16x8x8	16	16	8	8
1728	16x16x16x8	16	16	16	6
1729	12x12x10x6	12	12	10	6
1730	10x10x10x6	10	10	10	6
1731	12x12x10x4	12	12	10	4
1732	18x18x17x8	18	18	17	8
1733	22.5*12*10*6(瑞均中走丝)	22.5	12	10	8

### Cylinder series

code	Specifications	OD (mm)	H (mm)	ID (mm)
1734	25x10x10	25	10	10
1735	25x6x10	25	6	10
1736	18x16x12	18	16	12
1737	16x15x6	16	15	6
1738	19x10x10x4x6 (椭圆)	19x10	10	4x6







# EDM Copper Screw



- Product Name: conductive copper bar
- Model: copper bar with inner holes 6 and 8
- Material: Copper
- Function of wire cutting conductive block: in the process of wire cutting, when the current passes through the molybdenum wire and the workpiece, the upper and lower conductive blocks supply power for processing, and the upper and lower molybdenum wires are connected in parallel, so each section can bear half of the current, and the voltage loss on the molybdenum wire is also reduced by half, so it can bear higher current for processing.



# EDM Copper Screw



THAKUR JI MACHINE AND TOOLS



# EDM Copper Screw



THAKUR JI MACHINE AND TOOLS



# EDM Conductive Copper Screw

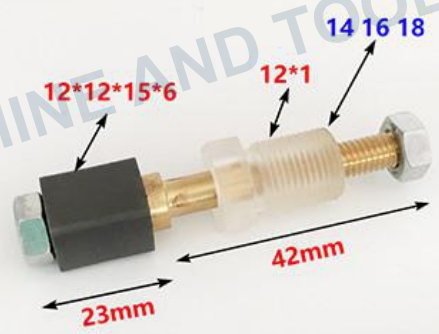
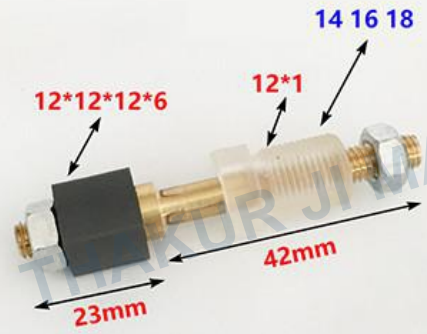
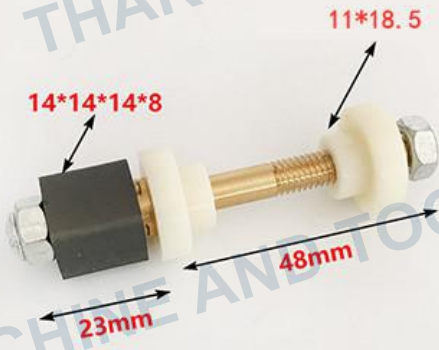
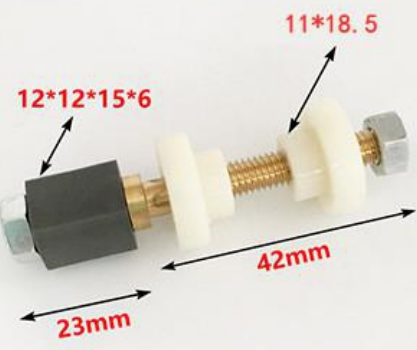
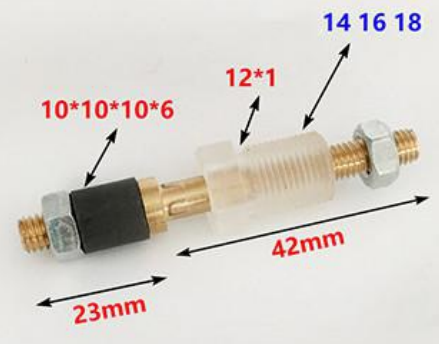
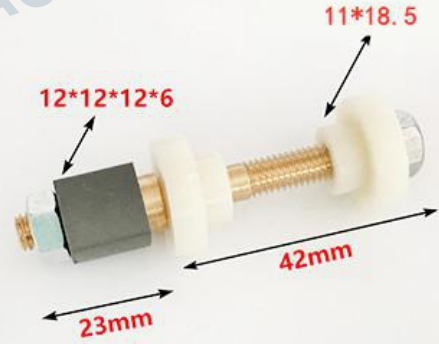
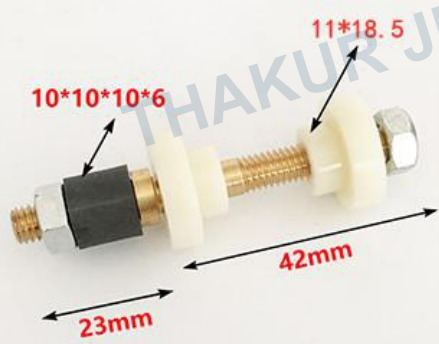

THAKUR JI MACHINE AND TOOLS





# EDM Mask



- Special nozzle for WEDM
- Material: Copper + Diamond / ceramic
- Specification: 0.155/0.192/0.195/0.215mm
- The outer diameter thread is 20 mm
- Product features
- It can greatly reduce the middle wire running
- The jitter of molybdenum wire in processing can improve the quality
- Stability, so as to improve the machining accuracy
- And surface finish.



# EDM Mask

- About eye mask: we usually use red and white nozzles,
- Red is made of ruby, while white is made of white ceramics. In fact, they play an important role
- Insulation, wear resistance is not high. Molybdenum wire works at high speed and is very sharp,
- The general material is not able to withstand the friction of molybdenum wire at high speed day and night.
- As we all know, the hardest material in nature is diamond, commonly known as diamond.
- The diamond nozzle is around the hole of ruby or white ceramic
- A circle of diamond material is inlaid to prevent molybdenum wire from splitting and stabilize molybdenum wire,
- The processed products are more smooth.



# EDM Mask

- Three levels:
- 1. Ordinary ruby. There is no diamond in this ruby, so it can't cut the taper. The product with taper is easy to cut, so it's not easy to cut
- There is no warranty.
- 2. For conventional diamond and ruby, this ruby is inlaid with diamond chip. It can be used for one year without cutting taper
- Time. This product is guaranteed for half a year
- 3. Original diamond and ruby. This ruby is inlaid with thickened diamond. The taper is less than 3 degrees. It has not been used for more than one year
- The problem is very serious. If there is a split within a year, it will be repaired free of charge. If it can't be repaired, it will be replaced free of charge.
- 4. If the eye mask is not within the scope of warranty and the service life is short, it can be dredged free of charge according to the situation. After half a year, Kong changed a little
- It's normal that there is no card





# EDM Mask





# EDM Mask

50\*50



50\*50

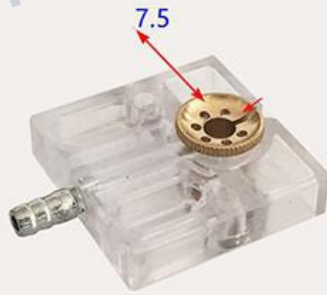

60\*60



50\*50



50\*50

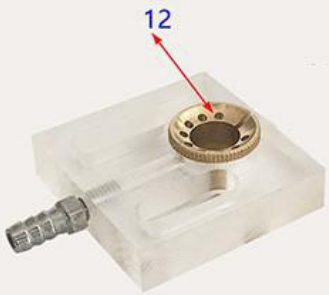

60\*60

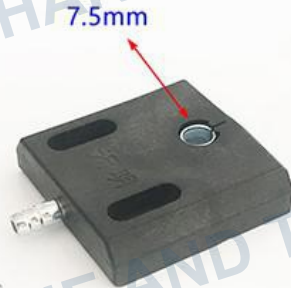

50\*50



50\*50





# Screw Rod

**18\*2\*430mm**



**20\*2\*435mm**

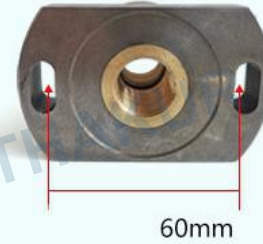



# Screw Rod

20\*3\*395mm

24\*3\*390mm

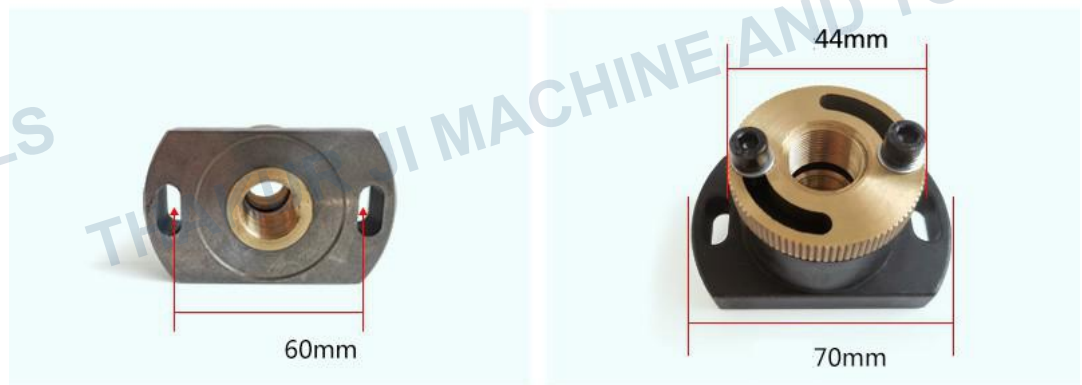





# Screw Rod

20\*1\*375mm



18\*1\*325mm





# Screw Rod

18\*1\*355mm



20\*1\*416mm



THAKUR JI MACHINE AND TOOLS



# Screw Rod

18\*2\*410mm

18\*2\*375mm

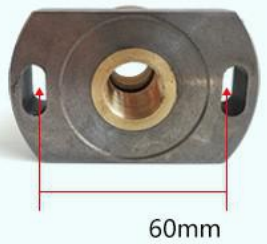





# EDM Resistor

150w 40Ω

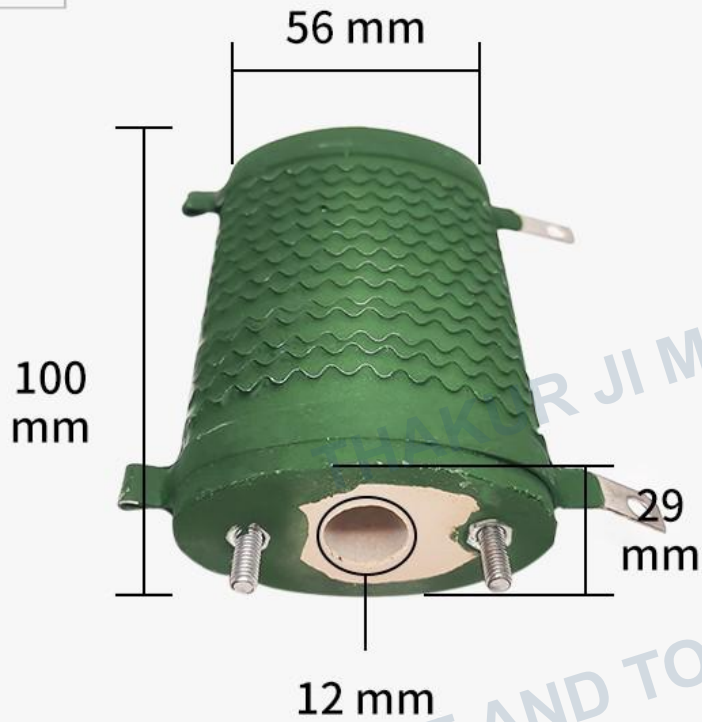

50w 5.1Ω





# EDM Resistor

75W 100Ω



75W 9.2Ω





# EDM Fitting



**nylon gear**

**Name:** Integrated Gear  
**Suitable for machinery**

**brand:** 乐奇机, 宇成机,  
雄峰机, 江州机, 德威机,  
泰州集成机, 长光机, 科迪  
机, 大明机

**external diameter:**  
119/118/116/114/111/1  
06/105/100mm



**Screw rod**

It can easily move the rotation  
change in a straight line, i.e  
Make it easy to give preloading  
and also follow your  
instructions

Work at your request

There are many kinds of screw  
rods with complete  
specifications. If you need  
special specifications, please  
contact customer service

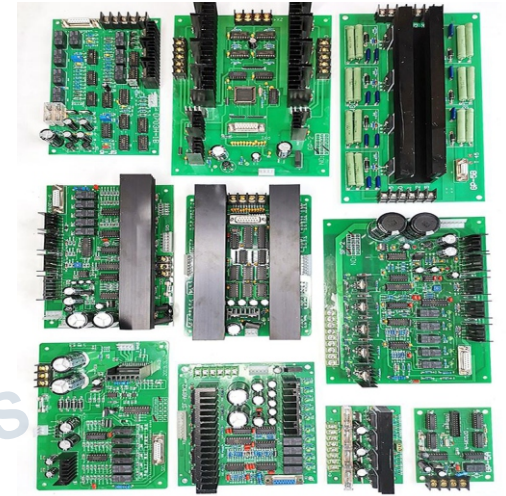

**DJ354系列**

**应用:** 激光冷却机、二氧化  
碳激光设备、半导体冷却、  
医疗设备冷却

**特点:** 带缺水保护功能、带  
堵转保护及过流保护功能、  
市场多年验证质量可靠

**类型:** 工业类



# Copper Electrode Tube



- Name: piercer brass pipe
- Specification: 0.3-3.0
- Size: 400mm-500mm
- High quality H65 brass materials, As raw material, strictly, Technical requirements, precision, Made from
- Stable performance, high perpendicularity, internal and external surface finish and strong corrosion resistance
- Wider application: brass pipe is suitable for the following materials: Steel (skd-ii), titanium, aluminum, graphite and materials with different hardness





# Copper Electrode Tube



- Name: Red copper pipe
- Specification: 0.3-3.0
- Size: 400mm-500mm
- Higher copper content ; T2 red copper is used as raw material and processed by strict technology. The quality is guaranteed and the quality is excellent
- Stable performance: easy to discharge water, no copper pipe plugging, fast drilling speed, wear resistance, not easy to explode, high perpendicularity, high internal and external surface finish and strong corrosion resistance
- Wider application: copper pipe is applicable to the following materials (copper, brass, tungsten steel, Kg5 \ w88% \ CO12%, tin, and materials with high hardness)



# Copper Electrode Tube

Electrode material	Diameter	Workpiece material	Drilling depth	Processing time	Electrode loss %
Brass H65	1	stainless steel	36	45min	52
	0.3	stainless steel	10	38min	115
	0.5	H45	50	1h 03min	59
	0.8	CR12	34	45min	48
	1.0	H45	200	15min	113
Red copper T2	1	Alloy steel	120	39min	210
	1	chisel tool steel	45	58min	60
	0.3	stainless steel	5	10min	105

# CONTACT US



Add : 01, Om Apt., Sahakar Nagar,  
Jivdani Cross Road, Virar (E) - 401 305.

Mob.: +91 9970014420 / 7970649340 / 7494072377

Email : [thakurjimachineandtools@gmail.com](mailto:thakurjimachineandtools@gmail.com)

Web.: [www.thakurjimachinetools.com](http://www.thakurjimachinetools.com)

THAKUR JI MACHINE AND TOOLS

THAKUR JI MACHINE AND TOOLS