



AFC3000

**FIXTURED
ELECTRIC
NUTRUNNER**



HFC3000II

**ELECTRIC
HANDHELD
NUTRUNNER**

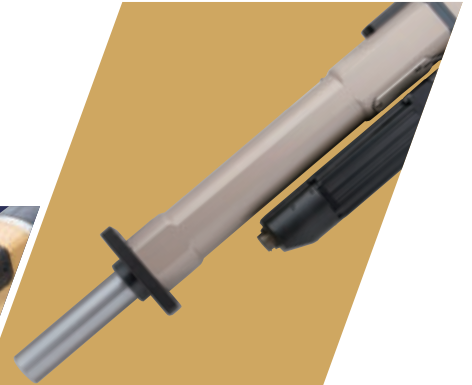

DSP3000

**DIGITAL
SERVO
PRESS**



ELECTRICAL ASSEMBLY TOOLS
DAI-ICHI DENTSU LTD.

NUTRUNNER / HAND-HELD TOOL / SERVO PRESS

Features

Production Process Flexibility

Maximum 32 spindles
multi spindle control

128 Parameters
64 Sequences

Quality and Traceability

ISO5393
compliant

12,000 Stored Data
100 Curve Data

Patented high speed seating mechanism

Cycle time
reduction

Torque overshoot
reduction

Wide Range of Tools

Minimum
0.2Nm

Maximum
5,000Nm

System Configuration (Image)

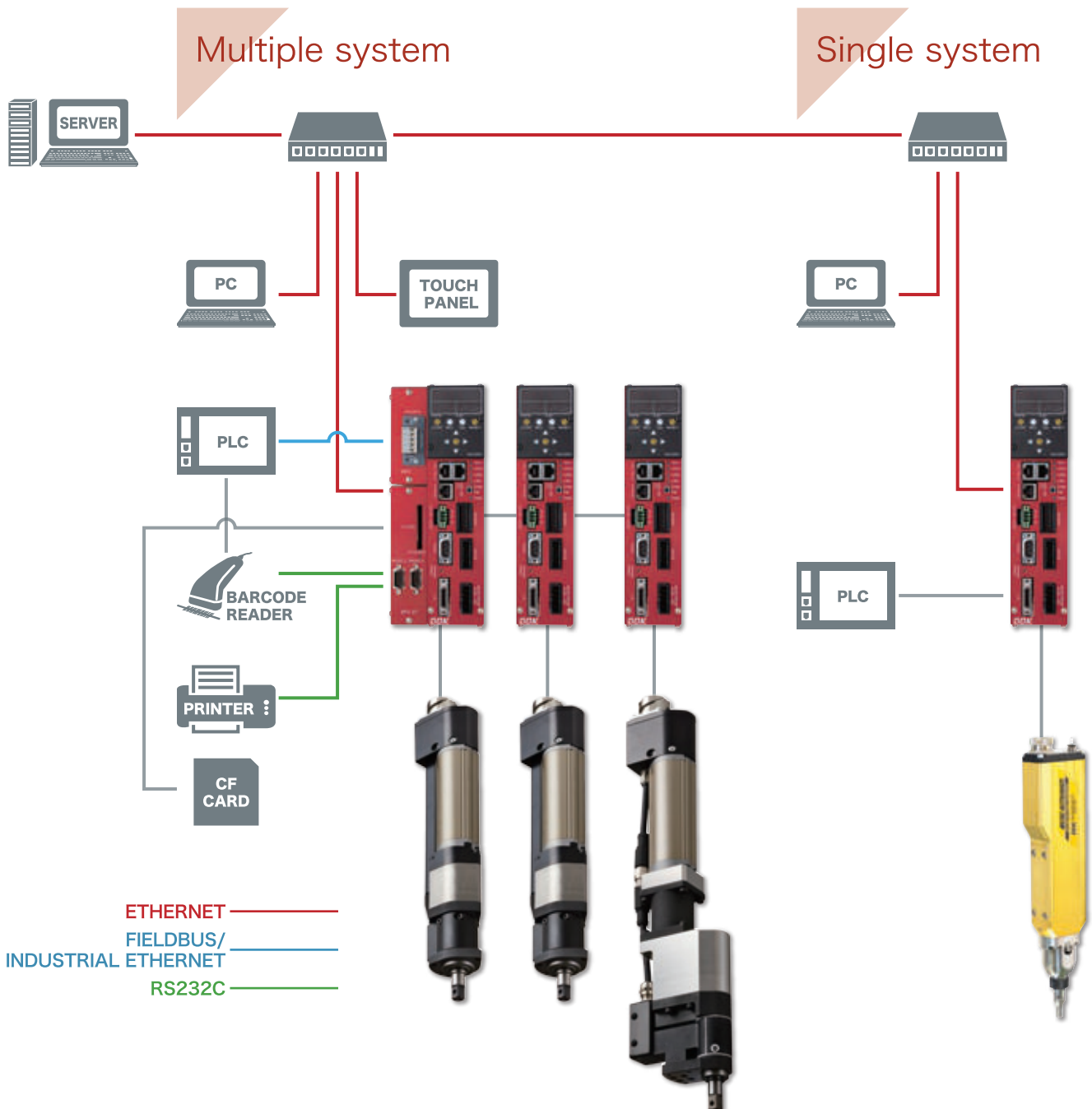

Control and Features

Torque method Tighten to the set target torque value.

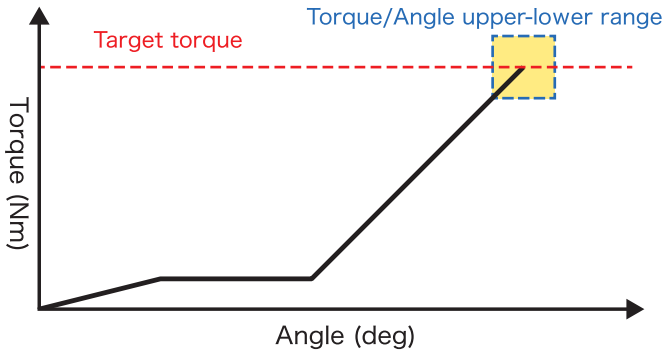

Angle method Tighten to the set target angle value.

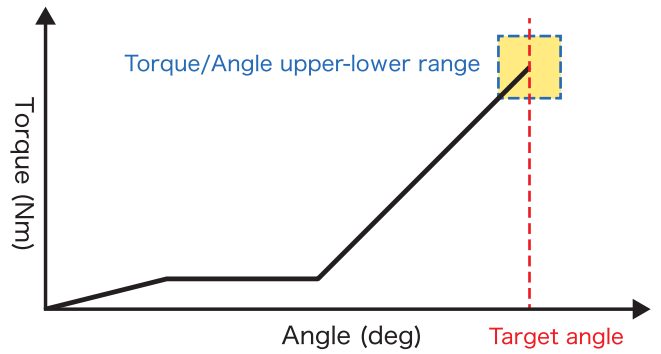

Rate judgement Monitor the torque / angle slope rise and judge if outside of the set limits.

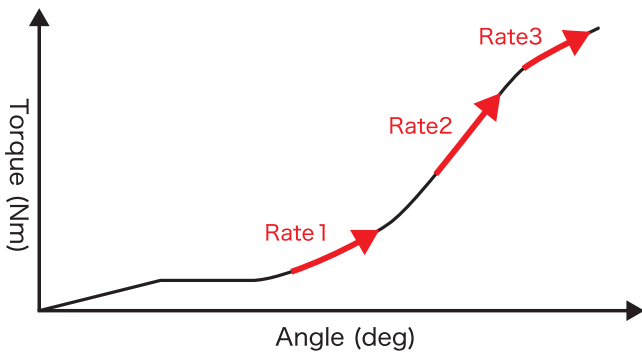

1 Pulse reverse Allows the disengagement of a locked fastener in the socket after tightening.

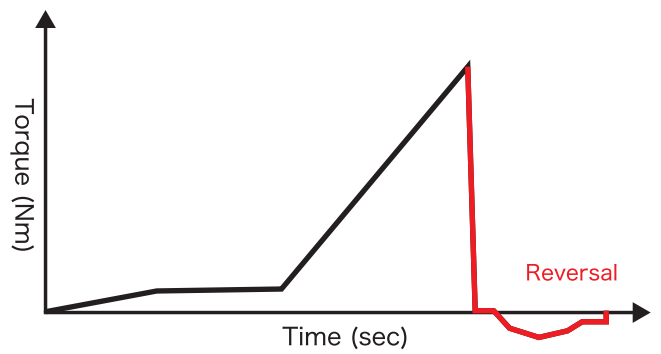

Residual torque checking method Detects residual torque by re-fastening a previously tightened fastener.

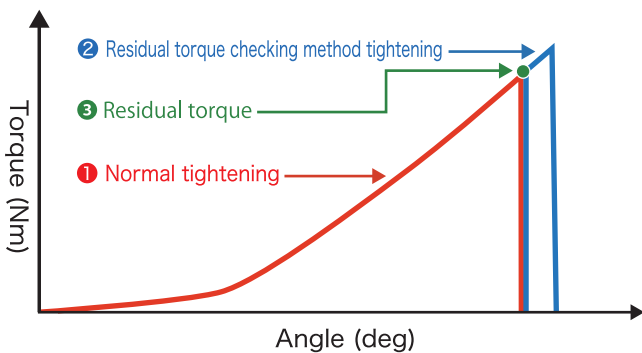

Torque recovery Reduces torque loss after fastening by maintaining torque for a set period of time.

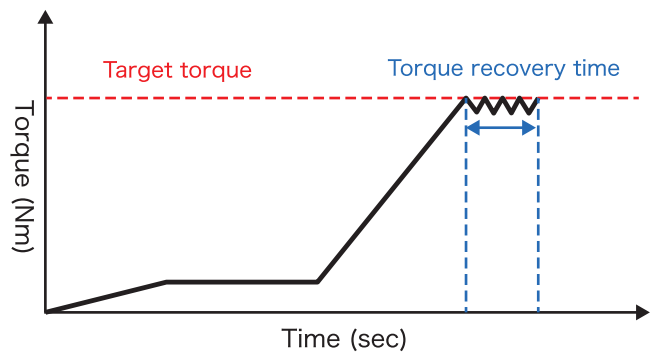

Reduce torque reaction Function to reduce the torque reaction after reaching set torque.

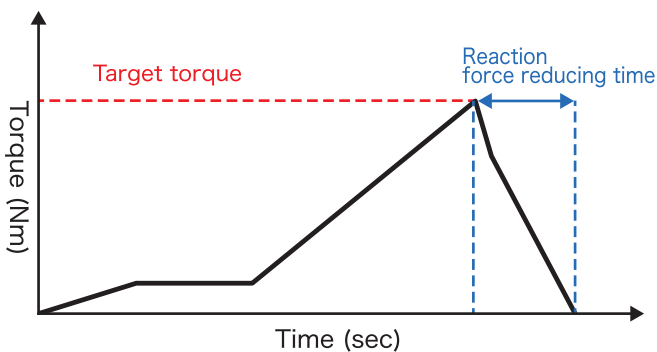

Offset check Function which allows the detection of adverse external torque (ie. external gearing) which could detriment actual dynamic torque applied.

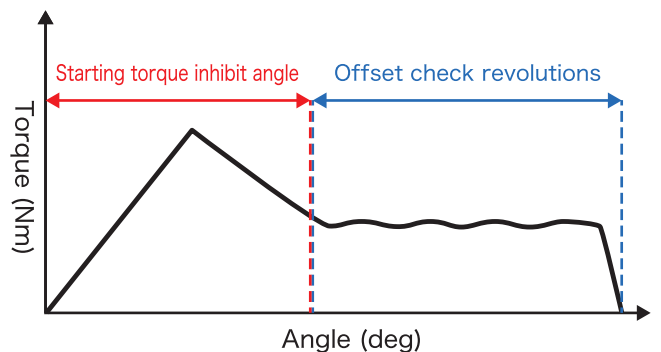

Controller and Expansion Unit

BASE UNIT

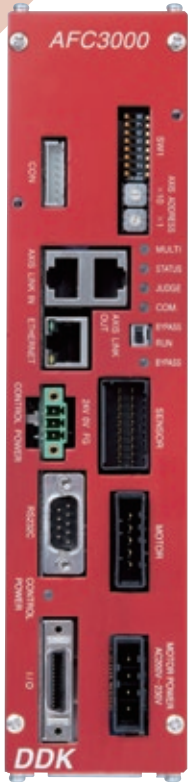

OPTIONAL UNIT



Display

User Friendly Display

- Displays full content with 6 digit / 2 row LED
- Easily operated cursor keys

Option1

Fieldbus I/O Interfaces

Various interfaces for direct PLC I/O & data connections

Option2

Expansion COM Ports and memory

- Compact Flash (CF) for result data
- Expansion RS232C Input / Output ports



Unit Model	MFC-S008	MFC-S024	MFC-S060	MFC-S120
Momentary Max. Peak Current	5.6Arms	17.0Arms	42.4Arms	84.8Arms
Transformer Capacity	0.3KVAxspindles	0.3KVAxspindles	0.8KVAxspindles	4.0KVAxspindles
Input power	single phase- AC100V-230V±10%	3-phase AC200~230V±10% 50/60H		
Control Power	DC24V±10% 0.5A		DC24V±10% 1A	
Operating Environment	temperature 0°C~+50°C humidity -below 90%RH			
RS232C communication	38400bps (default)/19200bps/9600bps, 1 port			
External analog monitor output	Torque analog voltage, angle pulse, CC/CW pulse etc.			
Axis Link Communication	Spindle Link Communication Port (connect Max. 32 spindles)			
Ethernet	PC communication port in conformity with IEEE802.3(100BASE-T)			
Standard I/O Connector	Input : 12	Output : 12		
Fastening Result Data memory	12000 Cycles max	500 last REJECT cycles		
TQ, Curve Memory	Last 100 Curves	Last 100 Reject Curves		

Controller	Tool Model Supported	display	option1	option2
MFC-S008	MFT-***M10-*			
MFC-S024	CFT-***RS1-*	MFC-DP01	Fieldbus Industrial Ethernet	CF CFEN
MFC-S060	NFT-***RM1/RM2-*			
MFC-S120	CFT-***RS3-*			
MFC-S120	NFT-***RM3-*			
MFC-S120	CFT-***RM4J-*			
MFC-S120	NFT-***RM5-*			

Optional model	Description	Unit Type
MFC-DT	Expansion Discrete I/O	
MFC-CC	Input : 32 Output : 32	
MFC-DN	CC-Link V2	
MFC-PB	DeviceNet	
MFC-EN	PROFIBUS DP-V1	Option1
MFC-PN	EtherNet/IP	
MFC-CI	PROFINET IO	
MFC-EC	CC-Link IE Field	
MFC-EC	EtherCAT	
MFC-CF	CompactFlash card supported	Option2
MFC-CFEN	Expansion RS232C(2port)	
MFC-CFEN	Ethernet for Server PC	
MFC-CFEN	CompactFlash card supported	
MFC-CFEN	Expansion RS232C(1port)	



Control Pac

FRONT PANEL



BOTTOM VIEW

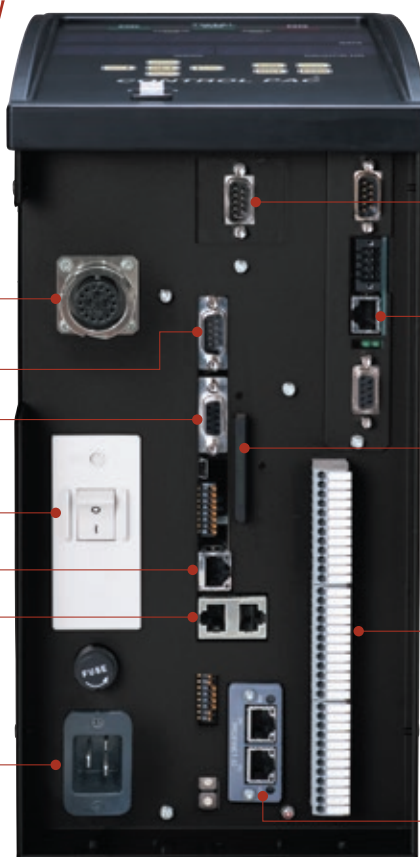

Tool cable connector

Connector for RS232C communication(data output)

T/A monitor connector

Power source breaker

Connector for Ethernet communication (PC communication)

Axis Link Communication Connector

Primary power source connector

Option: RS232C-2 communication connector (ID Data Input)

Option: Connector for special ethernet data output protocols

CF card slot

I/O Terminal

Various Fieldbus I/O interfaces

Unit Model	MFC-B060
Settings	Sequence: 64 Parameter: 128
Momentary Max. Peak Current	42.4Arms
Continuous AC Drive Current	5.2Arms
Input power	Single AC200~230V ±10%
Operating Environment	0°C~+45°C humidity below 90%RH
RS232C communication	38400bps (default)/19200bps/9600bps, 1port
External analog monitor output	Torque analog voltage, angle pulse, CC/CW pulse etc.
Axis Link Communication	Spindle Link Communication Port (connect Max. 32 spindles)
Ethernet	PC communication port in conformity with IEEE802.3(100BASE-T)
Standard I/O Connector	Input : 12 Output : 12
Option	Please refer to the Option1-4 on the left side
Fastening Result Data memory	12000 Cycles max 500 last Reject cycles
TQ. Curve Memory	Last 100 Curves Last 100 Reject Curves

	Adapted tool model	Standard cable
CFT tool	CFT-***RS1- CFT-***RS3-*	C30-FT3-M** (M=length in meter Std:5, 10, 15 Max 25m)
NFT tool(RM)	NFT-***RM1- NFT-***RM2- NFT-***RM3-*	C30-FM2-M** (M=length in meter Std:5, 10, 15 Max 25m)

Control Pac model information

MFC - B060 - CC - IO - CF - EN

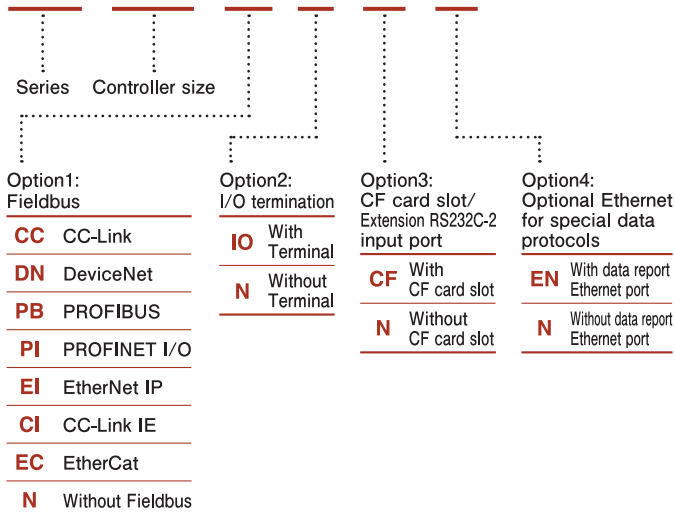

Internal PLC Logic control option: Ability to control external lights, switches and sensors without an external PLC

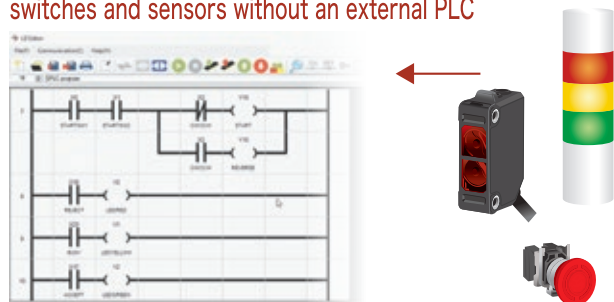

Nutrunner Tools



Download
the drawings
from here



MFT & CFT TOOLS

Tool type	Model	Max.Torque [Nm]	Max.Speed [rpm]	Weight [kg]	Length [mm] *1	Square drive [mm]	Min.Pitch [mm]	Applicable controller
Micro	MFT-080M10-S1	0.8	2220	0.68	206	Hex. 6.35	31	MFC-S008
	MFT-160M10-S	1.6	1250	0.68	206	Hex. 6.35	31	MFC-S008
	MFT-240M10-S	2.4	800	0.68	206	Hex. 6.35	31	MFC-S008
Straight	CFT-051RS1-S/SL	5	1330	1.16	270	9.5	41	MFC-S024
	CFT-101RS1-S/SL (-H)	10	3000	1.26	275	9.5	39	MFC-S024
	CFT-201RS1-S/SL (-H)	20	1293	1.42	290	9.5	39	MFC-S024
	CFT-281RS1-S/SL (-H)	28	992	1.42	293	9.5	39	MFC-S024
	CFT-401RS1-S/SL (-H)	40	712	1.42	293	9.5	39	MFC-S024
	CFT-801RS3-S/SL (-H)	80	1015	3.4	372	12.7	50	MFC-S060
	CFT-132RS3-S1/S1L (-H)	130	574	3.4	372	12.7	50	MFC-S060
	CFT-202RS3-S/SL	200	387	4.3	390	15.9	59	MFC-S060
	CFT-302RS3-S/SL	300	260	5.8	440	19	71	MFC-S060
	CFT-502RM4J-S	500	238	13.5	500	25.4	89	MFC-S120
	CFT-802RM4J-S	800	150	15	566	25.4	96	MFC-S120
	CFT-113RM4J-S	1100	120	22	618	38.1	99	MFC-S120
	CFT-153RM4J-S	1500	88	28.5	633	38.1	115	MFC-S120
Offset	CFT-201RS1-O/OL	20	1221	2	362	9.5	25	MFC-S024
	CFT-401RS1-O/OL	40	712	2.4	368	9.5	29	MFC-S024
	CFT-801RS3-O/OL	80	1015	6	456	12.7	35	MFC-S060
	CFT-132RS3-O1/O1L	130	574	7.5	484	15.9	39	MFC-S060
	CFT-202RS3-O/OL	200	387	8.2	514	15.9	45	MFC-S060
	CFT-302RS3-O/OL	300	260	13	583	19	55	MFC-S060
	CFT-502RM4J-O	500	238	23.5	692	25.4	62	MFC-S120
	CFT-802RM4J-O	800	150	31	788	25.4	71	MFC-S120
Angle head (Straight tool sold separately)	RA025-CFT	25	1941(101)	1.0	104	9.5	29	CFT-101/201RS1-S
	RA040-CFT	40	836(201)	1.3	135	9.5	37	CFT-201/281RS1-S
	RA060-CFT	60	460(401)	1.3	135	12.7	37	CFT-401RS1-S
	RA080-120-CFT	80	656(801)	2.0	157	12.7	42	CFT-801RS3-S
	RA130-120-CFT	130	656(801)	2.3	169	12.7	46	CFT-801RS3-S
	RA200-120-CFT	200	371(132)	2.7	196.5	15.9	56	CFT-132RS3-S1
	RA300-120-CFT	300	250(202)	5.0	248	19	67	CFT-202RS3-S

*1 Length means the length of standard tool including the square drive.Connector parts are not included. Please refer to the drawings from the above QR code.

CFT Spindle Adaptor

Model	Max.Torque [Nm]	Length [mm]	Stroke [mm]	Square drive [mm]	Applicable tool
CFT-SP401-40V	40	165	40	9.5	CFT-101RS1-S/SL (-H)
CFT-SP401-40HW	40	181	40	9.5	CFT-201RS1-S/SL (-H)
					CFT-281RS1-S/SL (-H)
					CFT-401RS1-S/SL (-H)
CFT-SP801-50V/H	80	217	50	12.7	CFT-801RS3-S/SL (-H)
CFT-SP132-50V/H	130	230	50	15.9	CFT-132RS3-S1/S1L (-H)
CFT-SP202-60V/H	200	253	60	19	CFT-202RS3-S/SL
CFT-SP302-70V/H	300	282	70	19	CFT-302RS3-S/SL
SP502Vertical/Horizontal	500	276	50	25.4	CFT-502RM4J-S

* V: For vertical tightening H: For horizontal tightening



Nutrunner Tools

Download
the drawings
from here

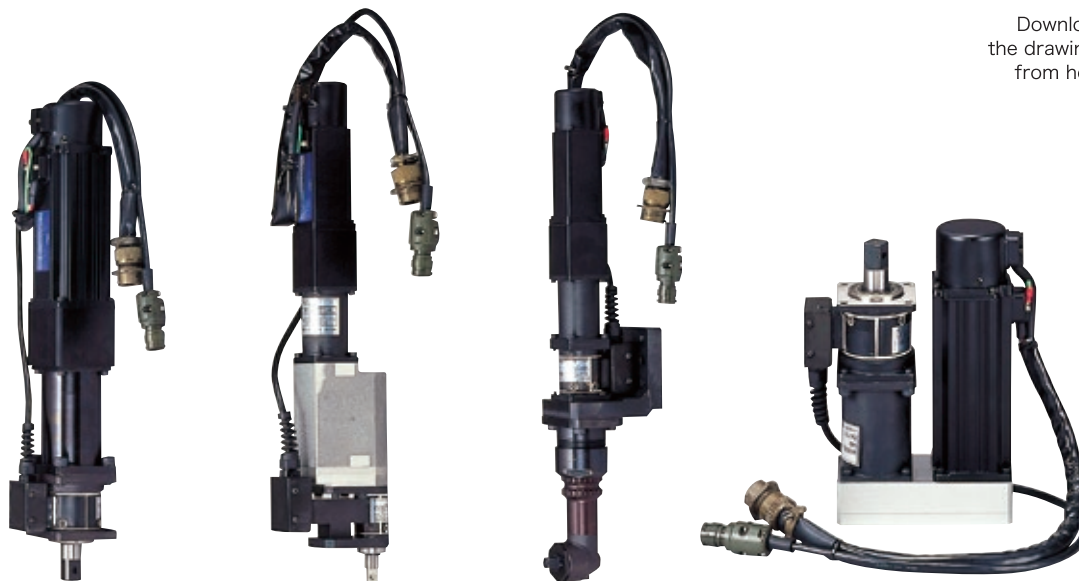

NFT TOOLS

Tool type	Model	Max.Torque [Nm]	Max.Speed [rpm]	Weight [kg]	Length [mm] *1	Square drive [mm]	Min.Pitch [mm]	Applicable controller
Straight	NFT-101RM1-S1	10	500	2.1	311	9.5	41	MFC-S024
	NFT-201RM1-S	20	500	2.1	311	9.5	41	MFC-S024
	NFT-301RM2A-S	30	600	2.1	367	9.5	41	MFC-S024
	NFT-401RM1-S	40	250	2.1	311	9.5	41	MFC-S024
	NFT-801RM3-S	80	500	4.5	408	12.7	61	MFC-S060
	NFT-132RM3-S	130	395	5.5	417	15.8	61	MFC-S060
	NFT-202RM3-S	200	220	6	438	15.8	63	MFC-S060
	NFT-302RM3-S	300	150	9	456	19	77	MFC-S060
	NFT-303RM5-S	3000	39	70	946	44.5	172	MFC-S120
NFT-503RM5-S	5000	22	90	930	50.8	207	MFC-S120	
Offset	NFT-201RM1-O	20	500	2.7	388	9.5	25	MFC-S024
	NFT-301RM2A-O	30	600	3	466	9.5	29	MFC-S024
	NFT-401RM1-O	40	250	3	410	9.5	29	MFC-S024
	NFT-801RM3-O	80	500	6.8	497	12.7	35	MFC-S060
	NFT-132RM3-O	130	395	8	537	15.8	39	MFC-S060
	NFT-202RM3-O	200	220	9.5	573	15.8	45	MFC-S060
	NFT-302RM3-O	300	150	13.5	606	19	55	MFC-S060
Angle	NFT-201RM1-A55	31	321	4.2	433.5	12.7	37	MFC-S024
	NFT-401RM1-A55	56	160	4.2	433.5	12.7	37	MFC-S024
	NFT-801RM3-A130	124	321	8.5	551.5	15.8	46	MFC-S060
	NFT-132RM3-A250U	202	250	11.3	580	15.8	57	MFC-S060
	NFT-202RM3-A250U	255	140	11.8	601	15.8	57	MFC-S060
	NFT-202RM3-A380	310	142	16.9	640	19	75	MFC-S060
	NFT-302RM3-A550	466	96	22.2	658	25.4	75	MFC-S060
U type	NFT-101RM1-S1U	10	500	2.5	141(150)	9.5	41	MFC-S024
	NFT-201RM1-SU	20	500	2.5	141(150)	9.5	41	MFC-S024
	NFT-401RM1-SU	40	250	2.5	141(150)	9.5	41	MFC-S024
	NFT-132RM3-SU	130	395	6.5	209(221)	15.8	61	MFC-S060
	NFT-202RM3-SU	200	220	7	230(221)	15.8	63	MFC-S060
	NFT-302RM3-SU	300	150	10	257(221)	19	77	MFC-S060

*1 Length means the length of standard tool including the square drive. Connector parts are not included. Please refer to the drawings from the above QR code.

NFT Spindle Adaptor

Model	Max.Torque [Nm]	Length [mm]	Stroke [mm]	Square drive [mm]	Applicable tool
SP201 Vertical/Horizontal	20	156	25	9.5	NFT-201RM1-S/SU
SP401 Vertical/Horizontal	40	180	40	9.5	NFT-401RM1-S/SU
SP801 Vertical/Horizontal	80	218	50	12.7	NFT-801RM3-S/SU
SP202 Vertical/Horizontal	200	237	50	15.8	NFT-132/202RM3-S/SU
SP302 Vertical/Horizontal	300	240	50	19	NFT-302RM3-S/SU



CFT Tool Features

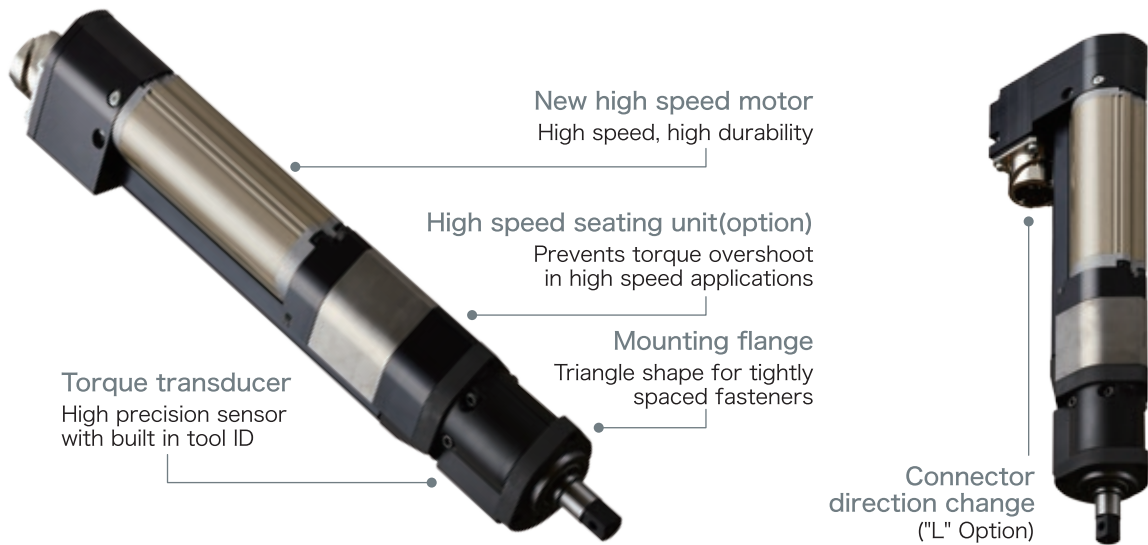

CFT Tool Model Information

CFT - 201 RS1 - S - H

Series name Tool size Motor type High speed seating option

Tool type

S	Straight
SL	Straight Tool Connector "L" Option
O	Offset
OL	Offset Tool Connector "L" Option

NFT Tool Model Information

NFT - 201 RM1 - S

Series name Tool size Motor type ※1

Tool type

S	Straight
O	Offset
A	Angle
SU	U type

※1 Option

RM1A/RM2A/RM3A
"A" type adds motor connector directly mounted

Touch Panel Features

5.7-inch touch panel for AFC3000 (GP-4301TM)

- Waveform and result data display available
- Parameters can be displayed and edited
- Judgment lamp display
- Equipped with support functions for equipment adjustment (Axis BYPASS, CAL)

Set Parameters without PC

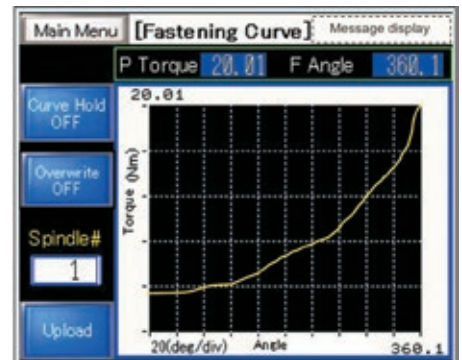

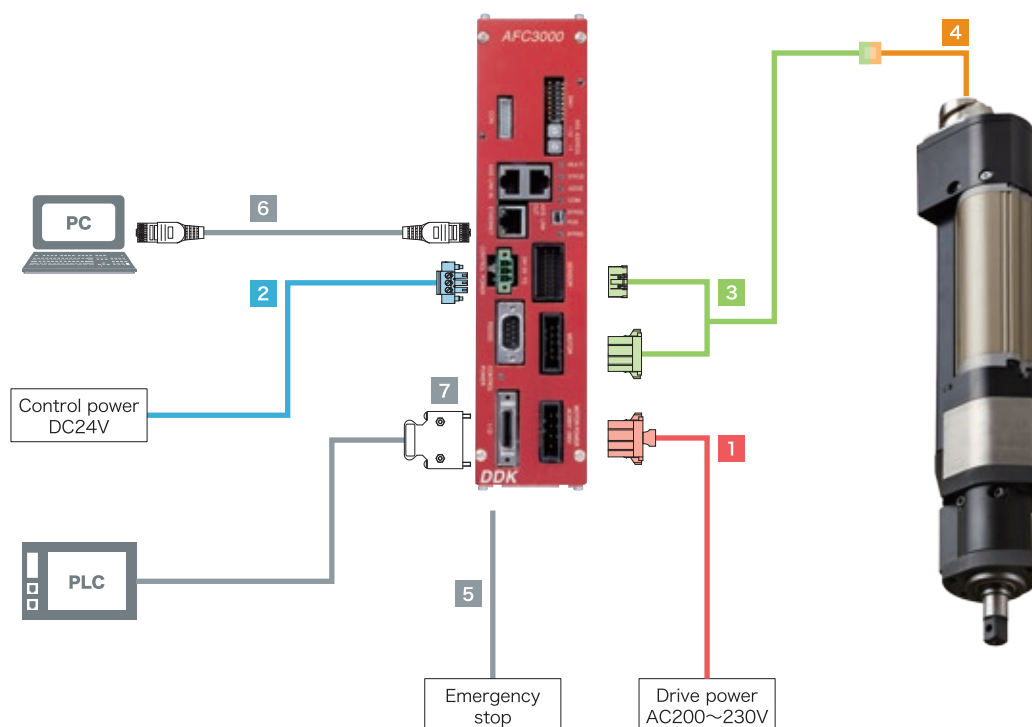

Cable Applicable Table

No.	Cable name	MFT**M10*	CFT**RS1*	CFT**RS3*	CFT**RM4J*	NFT**RM1*	NFT**RM2*	NFT**RM3*	NFT**RM5*	Model	Standard length	CE ^{*1}	Remarks
1	Drive power cable for MFC-S008/S024/S060	■	■	■		■	■	■		C15-D1-M*	2m		Included in controller
	Drive power cable for MFC-S008/S024/S060(CE type)	■	■	■		■	■	■		C15-D1-M*-UC	2m	○	_____
	Drive power cable for MFC-S120				■					■ C15-D2-M*	2m		Included in controller
	Drive power cable for MFC-S120(CE type)				■					■ C15-D2-M*-UC	2m	○	_____
2	Control power cable for MFC	■	■	■	■	■	■	■		■ C30-DC1-M*	2m		_____
	Control power connector for MFC									■ MC1.5/3-STF-3.81	_____		Included in controller
3	Tool cable for MFT	■								■ C30-FT2-M*	3m/5m/10m	○	_____
	Tool cable for CFT-RS1/RS3		■	■						■ C30-FT1-M*	5m/10m/15m	○	_____
	Tool cable for NFT-RM1/RM2/RM3					■	■	■		■ C30-FM1-M*	5m/10m/15m		For Robot type, please add"-R" to the end of the model
	Tool cable for CFT-RM4J,NFT-RM4H				■					■ C30-FW4-M*	5m/10m/15m		For Robot type, please add"-R" to the end of the model
	Motor cable for NFT-RM5								■	■ C15-M1-M*	5m/10m/15m		For Robot type, please add"-UR" to the end of the model
	Pre-amplifier & Resolver cable for NFT-RM5								■	■ C30-PR5-M*	5m/10m/15m		_____
4	Extension tool cable for MFT	■								■ C30-FT2-M*-E	3m/5m/10m	○	_____
	Extension tool cable for CFT-RS1/RS3		■	■						■ C30-FT1-M*-E	5m/10m/15m	○	_____
	Extension tool cable for NFT-RM1/RM2/RM3					■	■	■		■ C15-EF1-M*	2m/5m/10m		C15-EF2-M*-LR for robot type.
	Extension tool cable for CFT-RM4J,NFT-RM4H				■					■ C15-EF2-M*	2m/5m/10m		For Robot type, please add"-UR" to the end of the model
	Extension motor cable for NFT-RM5								■	■ C15-EM1-M*	5m		For Robot type, please add"-UR" to the end of the model
	Extension resolver cable for NFT-RM5								■	■ C15-ER1-M*	2m/5m/10m		For Robot type, please add"-UR" to the end of the model
	Extension pre-amplifier cable for all NFT motors					■	■	■		■ C15-EP1-M*	2m/5m/10m		For Robot type, please add"-UR" to the end of the model
5	Stop signal connector	■	■	■	■	■	■	■		■ MC1.5/2-STF-3.81	_____		Included in FieldBus Option 1
	Stop signal cable	■	■	■	■	■	■	■		■ C30-XA1-M2	2m		_____
6	Ethernet Crossover	■	■	■	■	■	■	■		■ C30-UL1-M3	3m		For direct connect
	Ethernet Straight	■	■	■	■	■	■	■		■ C30-UL2-M3	3m		For connect through HUB
7	Standard I/O connector	■	■	■	■	■	■	■		■ 10126-3000PE	_____		Included in controller
	Standard I/O cable	■	■	■	■	■	■	■		■ C30-SU1-M3	3m		_____
8	Axis communication cable	■	■	■	■	■	■	■		■ C15-A3-M03	0.3m		_____
	Axis communication connector	■	■	■	■	■	■	■		■ C30-AL2	_____		_____

*MFT,CFT tools are only compatible to CE.Please change to the control power cable to CE compatible model.
*You need to change the Control power cable model to "-UC" but you don't need to change any other cables.

Applications

Sliding arm for manual production

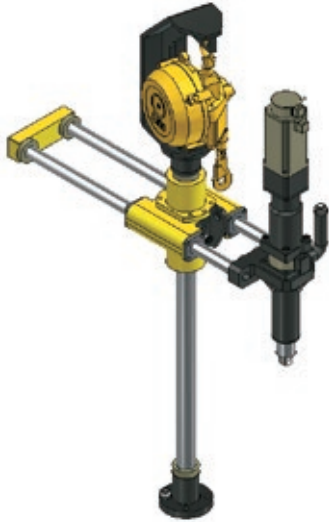

Multi-spindle manually-operated hanging head



Tire fastening systems

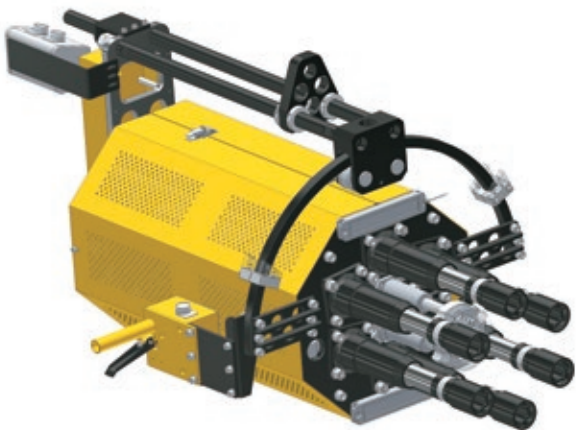

Open type, machine mount - variable pitch systems

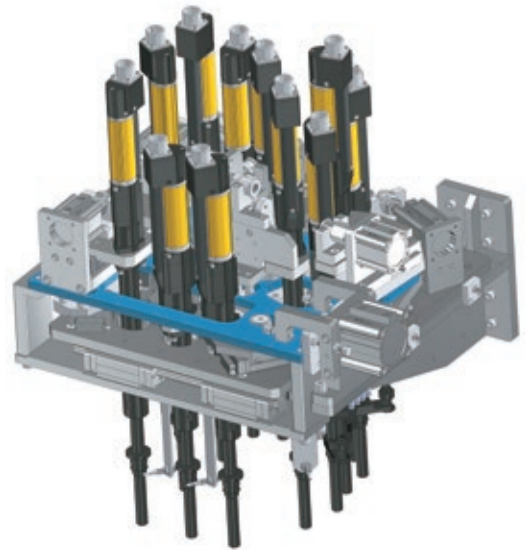

Robotic systems (with tool change function)

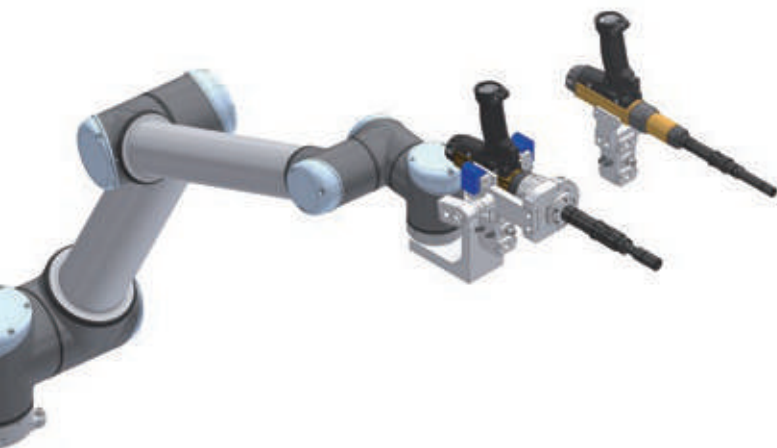

Dial table type Micro-nutrunner systems

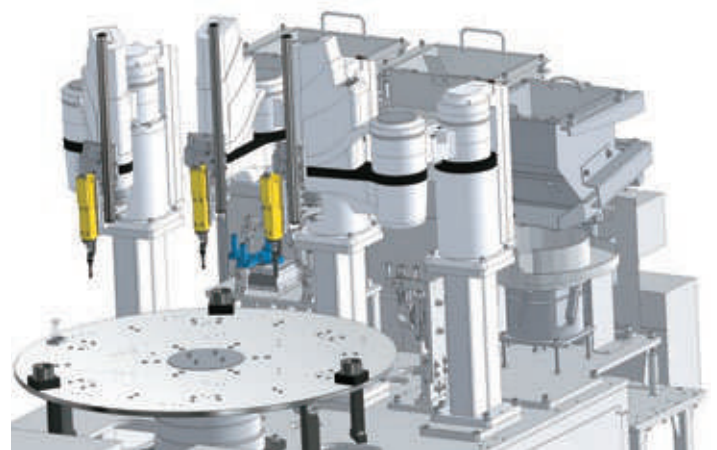

User Console Software

Setup / Monitor Software for Windows (MFC-UC-N)

- Simple graphic settings
 - Result data Collection & Storage
 - Fastening curve display and Excel format storage
 - Fastening Sequence function
- *Supported language: Japanese/English/Chinese/Korean/Indonesian

Control setting display

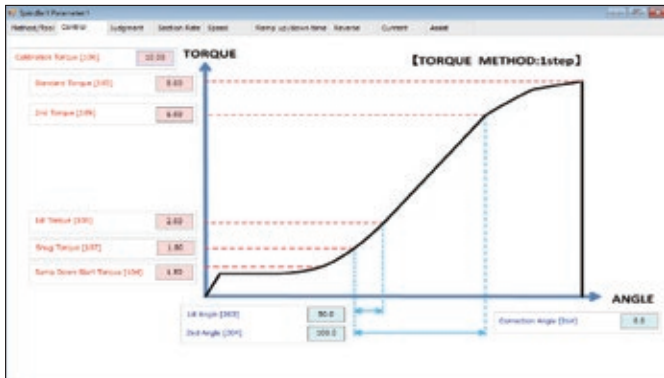

Speed setting display



Sequence setting display

Step	Command	Date 1	Date 2	Comment
1	Start Method			
2	Line Report	Parameter 1		ON
3	Repeat Jump	0		
4	1st Stop	Parameter 2		ON
5	Data Report			
6	Repeat Jump	0		
7	2nd Stop	Parameter 3		ON
8	Data Report			
9	2nd Cycle Data Report			
10				
11				
12				
13				
14				
15				
16				
17				
18				
19				
20				

I/O monitor

Input BANK	Output BANK1	Output BANK2	Output BANK3
1. Emergency Stop	Total Report	Sample 1	Report
2. Start	Total Sample	Sample 2	Alarm
3. Stop	Multi-Function	Sample 3	Alarm
4. Start	Ready	Sample 4	Ready
5. Sequence Select Bit 1	Stop	Sample 5	Ready
6. Sequence Select Bit 2	Stop	Sample 6	Ready
7. Sequence Select Bit 3	Sequence Select Bit 1	Sample 7	Parameter Select Bit 1
8. Sequence Select Bit 4	Sequence Select Bit 2	Sample 8	Parameter Select Bit 2
9. Cycle Count UP	Sequence Select Bit 3	Sample 9	Parameter Select Bit 3
10. Cycle Count Clear	Sequence Select Bit 4	Sample 10	Parameter Select Bit 4
11. Input Mask Port 1	Multi	Sample 11	Torque Recovery Rate
12. Input Mask Port 2	Multi	Sample 12	Sample 2
13. Input Mask Port 3	Multi	Sample 13	Peak Torque Low Report
14. Input Mask Port 4	Multi	Sample 14	Peak Torque High Report
15. Sample 1 Bit 1	Multi	Sample 15	Peak Torque High Report
16. Sample 2 Bit 1	Multi	Sample 16	Peak Torque High Report
17. Sample 3 Bit 1	Multi	Sample 17	Peak Torque High Report
18. Sample 4 Bit 1	Multi	Sample 18	Peak Torque High Report
19. Sample 5 Bit 1	Multi	Sample 19	Peak Torque High Report
20. Sample 6 Bit 1	Multi	Sample 20	Peak Torque High Report
21. Sample 7 Bit 1	Multi	Sample 21	Peak Torque High Report
22. Sample 8 Bit 1	Multi	Sample 22	Peak Torque High Report
23. Sample 9 Bit 1	Multi	Sample 23	Peak Torque High Report
24. Sample 10 Bit 1	Multi	Sample 24	Peak Torque High Report
25. Sample 11 Bit 1	Multi	Sample 25	Peak Torque High Report
26. Sample 12 Bit 1	Multi	Sample 26	Peak Torque High Report
27. Sample 13 Bit 1	Multi	Sample 27	Peak Torque High Report
28. Sample 14 Bit 1	Multi	Sample 28	Peak Torque High Report
29. Sample 15 Bit 1	Multi	Sample 29	Peak Torque High Report
30. Sample 16 Bit 1	Multi	Sample 30	Peak Torque High Report
31. Sample 17 Bit 1	Multi	Sample 31	Peak Torque High Report
32. Sample 18 Bit 1	Multi	Sample 32	Peak Torque High Report
33. Sample 19 Bit 1	Multi	Sample 33	Peak Torque High Report
34. Sample 20 Bit 1	Multi	Sample 34	Peak Torque High Report
35. Sample 21 Bit 1	Multi	Sample 35	Peak Torque High Report
36. Sample 22 Bit 1	Multi	Sample 36	Peak Torque High Report
37. Sample 23 Bit 1	Multi	Sample 37	Peak Torque High Report
38. Sample 24 Bit 1	Multi	Sample 38	Peak Torque High Report
39. Sample 25 Bit 1	Multi	Sample 39	Peak Torque High Report
40. Sample 26 Bit 1	Multi	Sample 40	Peak Torque High Report
41. Sample 27 Bit 1	Multi	Sample 41	Peak Torque High Report
42. Sample 28 Bit 1	Multi	Sample 42	Peak Torque High Report
43. Sample 29 Bit 1	Multi	Sample 43	Peak Torque High Report
44. Sample 30 Bit 1	Multi	Sample 44	Peak Torque High Report
45. Sample 31 Bit 1	Multi	Sample 45	Peak Torque High Report
46. Sample 32 Bit 1	Multi	Sample 46	Peak Torque High Report
47. Sample 33 Bit 1	Multi	Sample 47	Peak Torque High Report
48. Sample 34 Bit 1	Multi	Sample 48	Peak Torque High Report
49. Sample 35 Bit 1	Multi	Sample 49	Peak Torque High Report
50. Sample 36 Bit 1	Multi	Sample 50	Peak Torque High Report
51. Sample 37 Bit 1	Multi	Sample 51	Peak Torque High Report
52. Sample 38 Bit 1	Multi	Sample 52	Peak Torque High Report
53. Sample 39 Bit 1	Multi	Sample 53	Peak Torque High Report
54. Sample 40 Bit 1	Multi	Sample 54	Peak Torque High Report
55. Sample 41 Bit 1	Multi	Sample 55	Peak Torque High Report
56. Sample 42 Bit 1	Multi	Sample 56	Peak Torque High Report
57. Sample 43 Bit 1	Multi	Sample 57	Peak Torque High Report
58. Sample 44 Bit 1	Multi	Sample 58	Peak Torque High Report
59. Sample 45 Bit 1	Multi	Sample 59	Peak Torque High Report
60. Sample 46 Bit 1	Multi	Sample 60	Peak Torque High Report
61. Sample 47 Bit 1	Multi	Sample 61	Peak Torque High Report
62. Sample 48 Bit 1	Multi	Sample 62	Peak Torque High Report
63. Sample 49 Bit 1	Multi	Sample 63	Peak Torque High Report
64. Sample 50 Bit 1	Multi	Sample 64	Peak Torque High Report
65. Sample 51 Bit 1	Multi	Sample 65	Peak Torque High Report
66. Sample 52 Bit 1	Multi	Sample 66	Peak Torque High Report
67. Sample 53 Bit 1	Multi	Sample 67	Peak Torque High Report
68. Sample 54 Bit 1	Multi	Sample 68	Peak Torque High Report
69. Sample 55 Bit 1	Multi	Sample 69	Peak Torque High Report
70. Sample 56 Bit 1	Multi	Sample 70	Peak Torque High Report
71. Sample 57 Bit 1	Multi	Sample 71	Peak Torque High Report
72. Sample 58 Bit 1	Multi	Sample 72	Peak Torque High Report
73. Sample 59 Bit 1	Multi	Sample 73	Peak Torque High Report
74. Sample 60 Bit 1	Multi	Sample 74	Peak Torque High Report
75. Sample 61 Bit 1	Multi	Sample 75	Peak Torque High Report
76. Sample 62 Bit 1	Multi	Sample 76	Peak Torque High Report
77. Sample 63 Bit 1	Multi	Sample 77	Peak Torque High Report
78. Sample 64 Bit 1	Multi	Sample 78	Peak Torque High Report
79. Sample 65 Bit 1	Multi	Sample 79	Peak Torque High Report
80. Sample 66 Bit 1	Multi	Sample 80	Peak Torque High Report
81. Sample 67 Bit 1	Multi	Sample 81	Peak Torque High Report
82. Sample 68 Bit 1	Multi	Sample 82	Peak Torque High Report
83. Sample 69 Bit 1	Multi	Sample 83	Peak Torque High Report
84. Sample 70 Bit 1	Multi	Sample 84	Peak Torque High Report
85. Sample 71 Bit 1	Multi	Sample 85	Peak Torque High Report
86. Sample 72 Bit 1	Multi	Sample 86	Peak Torque High Report
87. Sample 73 Bit 1	Multi	Sample 87	Peak Torque High Report
88. Sample 74 Bit 1	Multi	Sample 88	Peak Torque High Report
89. Sample 75 Bit 1	Multi	Sample 89	Peak Torque High Report
90. Sample 76 Bit 1	Multi	Sample 90	Peak Torque High Report
91. Sample 77 Bit 1	Multi	Sample 91	Peak Torque High Report
92. Sample 78 Bit 1	Multi	Sample 92	Peak Torque High Report
93. Sample 79 Bit 1	Multi	Sample 93	Peak Torque High Report
94. Sample 80 Bit 1	Multi	Sample 94	Peak Torque High Report
95. Sample 81 Bit 1	Multi	Sample 95	Peak Torque High Report
96. Sample 82 Bit 1	Multi	Sample 96	Peak Torque High Report
97. Sample 83 Bit 1	Multi	Sample 97	Peak Torque High Report
98. Sample 84 Bit 1	Multi	Sample 98	Peak Torque High Report
99. Sample 85 Bit 1	Multi	Sample 99	Peak Torque High Report
100. Sample 86 Bit 1	Multi	Sample 100	Peak Torque High Report

Fastening result monitor

Sample No.	Start Date	Time	Sample No.	Time	Sample Judgment	SR No.	Report Name	Sample Cycle
88	2023-09-28	13:47:28	0	0	OK			76
89	2023-09-28	13:48:28	0	0	OK			77
90	2023-09-28	14:40:57	0	0	OK			88
91	2023-09-28	15:40:03	0	0	OK			89
92	2023-09-28	15:42:28	0	0	OK			90
93	2023-09-28	17:32:53	0	0	OK			91
94	2023-09-28	17:33:28	0	0	OK			92
95	2023-09-28	17:35:28	0	0	OK			93
96	2023-09-28	17:38:28	0	0	OK			94
97	2023-09-28	17:39:28	0	0	OK			95
98	2023-09-28	18:39:28	0	0	OK			96
99	2023-09-28	18:39:28	0	0	OK			97
100	2023-09-28	18:39:28	0	0	OK			98
76	2023-09-28	18:08:17	0	0	SECOND TIME HIGH REJECT		SECOND TIME HIGH REJECT	87
77	2023-09-28	18:08:17	0	0	OK			88
78	2023-09-28	18:08:17	0	0	OK			89
79	2023-09-28	18:08:17	0	0	OK			90
80	2023-09-28	18:08:17	0	0	OK			91

Fastening curve monitor

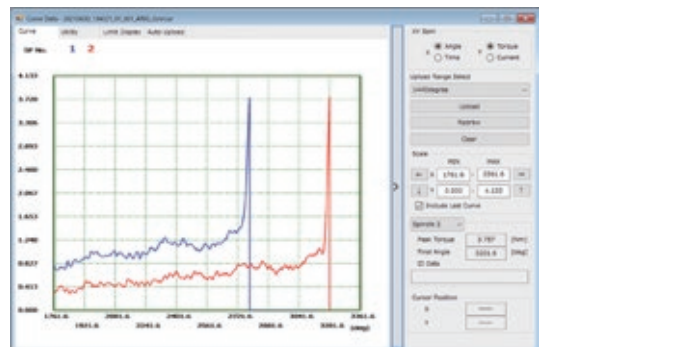

Features

EVOLUTIONARY HAND HELD ELECTRIC NUTRUNNER

High Performance and Flexible Hand Held NUTRUNNER

Compact and high durability resolver-based Servo Motor on a proven hardware platform.



FASTENING

- Torque (Angle monitor) or Angle (Torque monitor) Control fastening.
- Judgment by Torque Rate, Time and total rundown revolution monitoring.
- Built in Gyro sensor for ergonomic / safety (Pistol type Tool) operation. Senses grip swing motion.
- Built in simple Sequence function. (Batch count, Multiple parameter.)
- The "Patented Anti Cross Thread Function" is achieved by detecting the level of bolt engagement. (Option) (Patent No. 6412041)

CONTROLLER

- 64 Parameters Sets. (Selectable)
- Field bus connection. CC-Link, DeviceNet, Ethernet I/P, Profibus and others. (Optional)
- PC base user console (software) connection via Ethernet.
- Single phase power with wide voltage range : 100VAC-240VAC. (Auto sensing)
- Large, bright 6,3,3 digit (7 segment) LED (2 rows) located on front panel with easy to operate cursor function dedicated buttons.

TOOL

- Motor : Improved dust-proof, oil-proof and reduced sized permanent magnet motor.
- Pre-amplifier : Embedded high-accuracy amplification of torque transducer signal and TOOL-ID system.

QUALITY MANAGEMENT

- In-process inspection of the fastening cycle by monitoring torque, angle, torque rate and time.
- Visual (LED) and audio confirmation of fastening.
- Store up to 12,000 cycles of fastening data, 100 curve data and 500 abnormal history automatically.
- Store 1.8 milion (8MB CF) fastening resultant data on Compact Flash memory card. (Optional module)

User Console Software

Setup / Monitor Software for Windows (HFC-UC-N)

- Parameter edit and save.
- Data Monitor, Stored data (12,000 Cycles) and curve (100 Cycles) can be uploaded.
- Fastening curve can be displayed and automatically saved.
- Reject and abnormal report file can be created separately.

*Supported language:
Japanese/English/Chinese/Korean/Indonesian

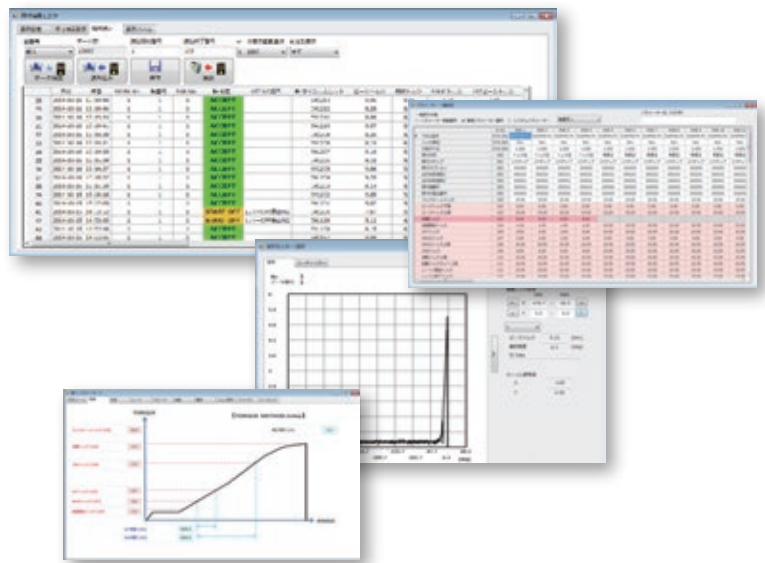

Software PLC

Built-in PLC Function

No control panels result in cost savings.

Direct control of lamps, switches, conveyors is possible.(Input:13 Output:12)

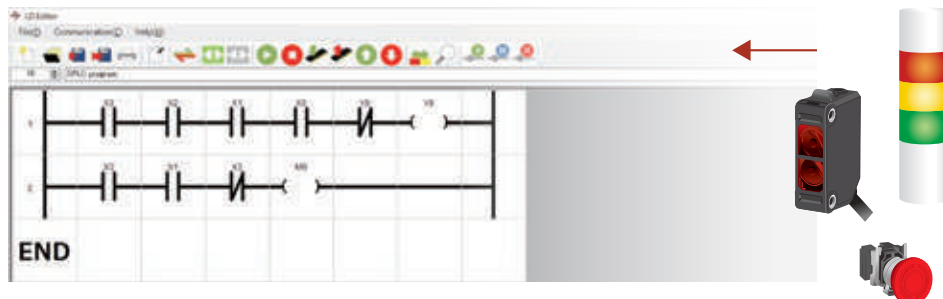

*Dedicated software required.

F Server

HFC3000II can improve reliability of quality control by interfacing to customers database.

Specifications

- Up to 32 station can be connected.
- 100Mbps Ethernet Connection.
- Works with AFC, HFC, and DSP System.

Data Saving

- TEXT File format.
- File can be created by Date/ Time or Part ID.

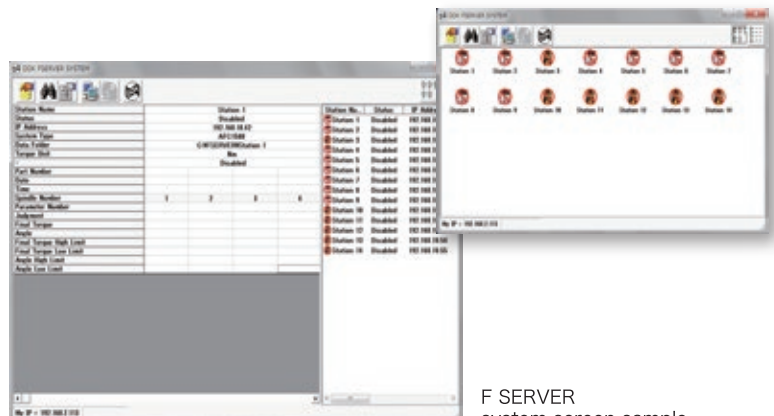

F SERVER system screen sample

Handheld Nutrunner Tools

Ergonomic design.
High speed, Light weight
Tool with built-in
motion (Gyro) sensor for
safety.



For limited space
applications.

Pistol Grip Tool

Tool type	Max. Torque [N·m]	Torque Range [N·m]	Max. Speed [rpm]	Length [mm]	Weight [kg]	Output Drive Size [mm]
HFT-015M50-P1	15	3.8~15	1,190	218	1.1	9.5 (3/8)
HFT-030M120-P1	30	7.5~30	1,540	260	1.8	9.5 (3/8)
HFT-035M80-P1	35	8.8~35	778	242	1.37	9.5 (3/8)
HFT-035M80-P1-X (Top Cable Connection)	35	8.8~35	778	242	1.37	9.5 (3/8)
HFT-050M120-P1	50	12.5~50	869	260	1.8	9.5 (3/8)
HFT-060M80-P1-X	60	15~60	461	275	2.5	12.7 (1/2)
HFT-080M120-P1	80	20~80	570	266	1.9	12.7 (1/2)
HFT-200M120-P1	200	50~200	216	317	3.3	19.0 (3/4)

Angle Tool

Tool type	Max. Torque [N·m]	Torque Range [N·m]	Max. Speed [rpm]	Length [mm]	Weight [kg]	Output Drive Size [mm]
HFT-015M50-A1-20	15	3.8~15	1,215	369	1.6	9.5 (3/8)
HFT-025M80-A1-20	25	6.3~25	1,070	389	1.7	9.5 (3/8)
HFT-040M80-A1-20	40	10~40	648	414	1.93	9.5 (3/8)
HFT-060M80-A-20	60	15~60	446	414	1.95	12.7 (1/2)
HFT-080M120-A-20	80	20~80	557	459.8	3	12.7 (1/2)
HFT-130M120-A-20	130	32.5~130	316	484.8	3.3	12.7 (1/2)
HFT-200M120-A-20	200	50~200	206	512.3	3.7	15.9 (5/8)
HFT-300M120-A-20	300	75~300	144	586	6.2	19.0 (3/4)

*CE compliant models are indicated by "CE" at the end. (e.g., HFT-040M80-A1-20-CE)

*Pistol tools and straight tools with "Anti Cross Thread Function" are indicated by "GA" at the end. (e.g., HFT-030M120-P1-GA)

*Please contact us for more details on angle tools.



For semi/automatic
fixtured & handheld
applications.
(Requires
telescopic torque
tube or mounting
plate)



Automatic start by
pushing Tool down on
fastener.
High speed seating
damper. (Optional)
No torque reaction using a
telescopic torque tube.
Horizontal or Vertical use.

Straight Tool

Tool type	Max. Torque [N·m]	Torque Range [N·m]	Max. Speed [rpm]	Length [mm]	Weight [kg]	Output Drive Size [mm]
HFT-010M50-S1-20	10	2.5~10	1,800	331	1.3	9.5 (3/8)
HFT-015M80-S1-20	15	3.75~15	1,600	351	1.4	9.5 (3/8)
HFT-025M80-S1-20	25	6.25~25	1,000	351	1.43	9.5 (3/8)
HFT-040M80-S-20	40	10~40	694	351	1.43	9.5 (3/8)
HFT-055M120-S-20	55	13.75~55	861	404.5	2.4	12.7 (1/2)
HFT-090M120-S-20	90	22.5~90	488	417.5	2.7	12.7 (1/2)
HFT-130M120-S-20	130	32.5~130	318	417.5	2.7	12.7 (1/2)

Straight Tool (Push to Start)

Tool type	Max. Torque [N·m]	Torque Range [N·m]	Max. Speed [rpm]	Length [mm]	Weight [kg]	Output Drive Size [mm]
HFT-030M80-DP-H	30	7.5~28	980	288	1.8	9.5 (3/8)

Sample Application



Controller

FRONT PANEL

OK (ACCEPT)

Lights when the fastening result is within all programmed limits.

TOTAL OK (ACCEPT)

Lights when the number of fastening accepts set in the batch program are achieved.

TORQUE

Lights when torque values are selected to be displayed.

6 digit 7 segment LED

Preset data ,result ,other data display.

3 digit 7 segment LED

Work Number (parameter) display.



Work select, Data set cursor button.

SET

Button for setting program changes.



NG (REJECT)

Lights when the fastening result is outside of programmed limits.

ANGLE

Lights when angle values are selected to be displayed.

3 digit 7 segment LED

Cycle count / Data number display.

CAL

Button for manual calibration check.

PRG

Button for selecting Run or Program mode.

RST

Button for resetting controller.

POWER

Main power switch

Controller type	HFC-B024A
Drivable Motor type	M50 M80 M120
Input Power Voltage	Single phase 100 to 240VAC ±10%
Input Power Frequency	Both 50 / 60 Hz
Rated Power Consumption	120W
Peak Current	19A

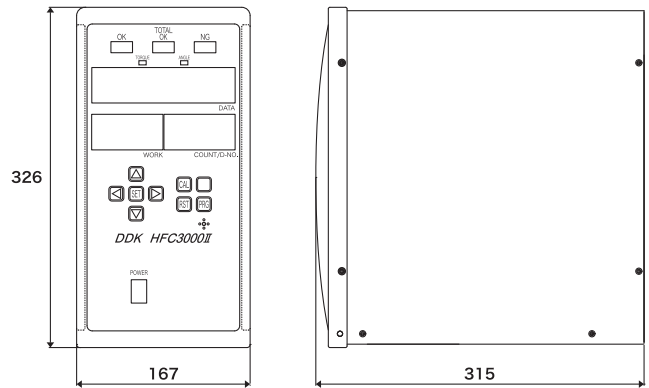

Tool Cable

Part #	Length [m]	Remarks
C15-F7-M5	5	
C15-F7-M10	10	
C15-F7-M15	15	
C15-EF7-M5	5	Extension
C15-EF7-M10	10	Extension
C30-F8-M5-CE	5	CE
C30-F8-M10-CE	10	CE
C30-F8-M15-CE	15	CE

Highly durable cable is used for all models



*Maximum cable length is 15m.

BOTTOM VIEW

RS232C-2
ID data input.

RS232C-1
Fastening result data Output.
Utilized for connection to a PLC,
printer, personal computer, etc.

TOOL cable connector

T/A MON.
Monitor output for Torque, Angle pulse,
Current, speed.

Electrical Leakage Breaker / Ground Fault detector.
Tool, Cable, Controller ground
leakage sensing for safe operation.
I = On
O = Off

Primary power-supply input connection.
Input for 100~240 VAC single-phase
50/60Hz. +/- 10%
AUTO SWITCHING.

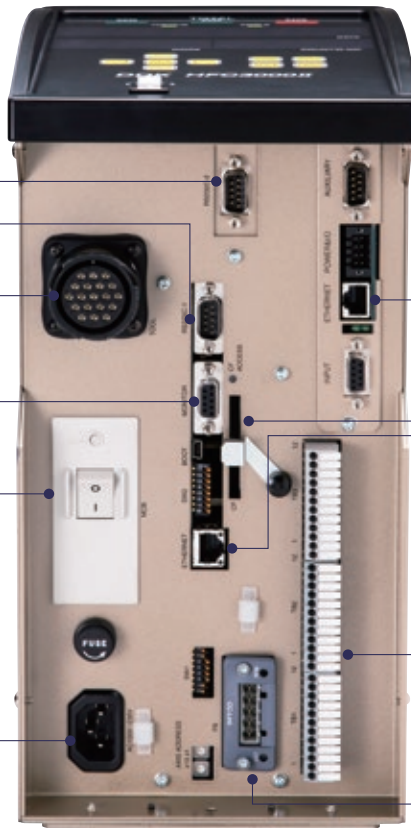

DATA REPORT ETHERNET
Optional Ethernet port for reporting data
in special protocols.
(FECNET, QDAS, TOOLSNET, etc)

CF CARD
Fastening result, and curve data can be
stored. (Optional)

ETHERNET
Ethernet port for connecting the HFC3000
Userconsole software PC.

TB1
Discrete I/O (Inputs / Outputs) connection.

FIELDBUS Connection
CC-Link, DeviceNet, Ethernet I/P, Profibus or
others can be added as option.

Controller Model

HFC - B024A - CC - IO - CF - EN - CE

Series Name Servo Size

Option 1 : Fieldbus	
CC	CC-Link V1/V2
DN	DeviceNet
PB	PROFIBUS-DP V1
PI	PROFINET I/O
EI	EtherNet IP
EC	EtherCAT
CI	CC-Link IE Field
FB	Base plate only
N	Without Fieldbus

Option 2 : Terminal	
IO	With Terminal
N	Without Terminal

Option 3 : CF card slot Extension RS232C-S input port	
CF	With CF card slot
N	Without CF card slot

Option 4 : Data Report Ethernet port	
EN	With Data Report Ethernet port
N	Without Data Report Ethernet port

Option 5 : CE compliant	
CE	Yes
N	No



*HFC3000II compliant to CE. Necessary to select with CE compliant.

Accessories/Applications

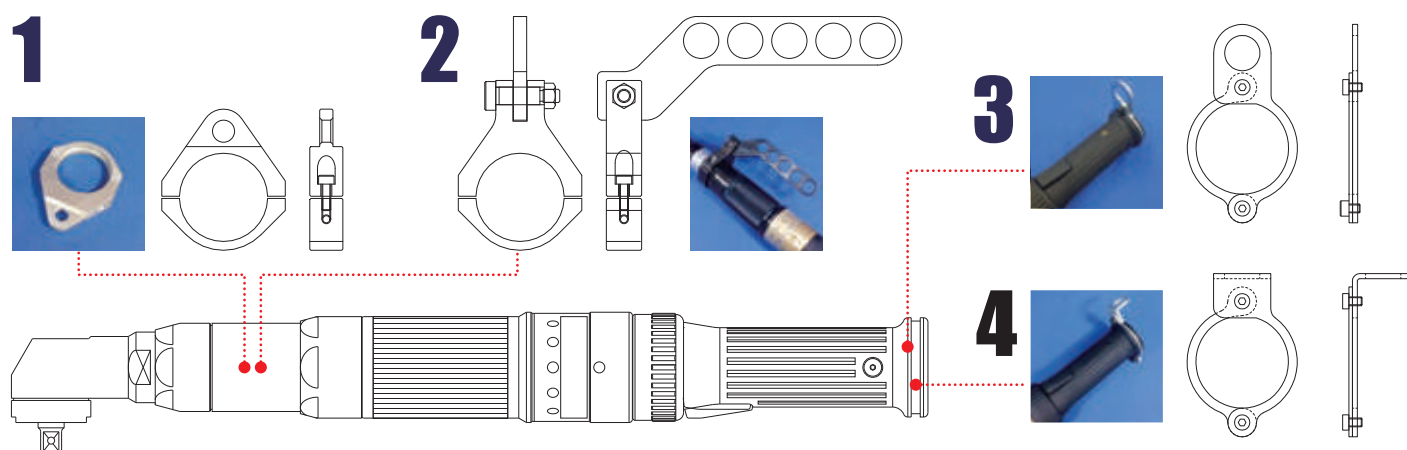

Angle Tool

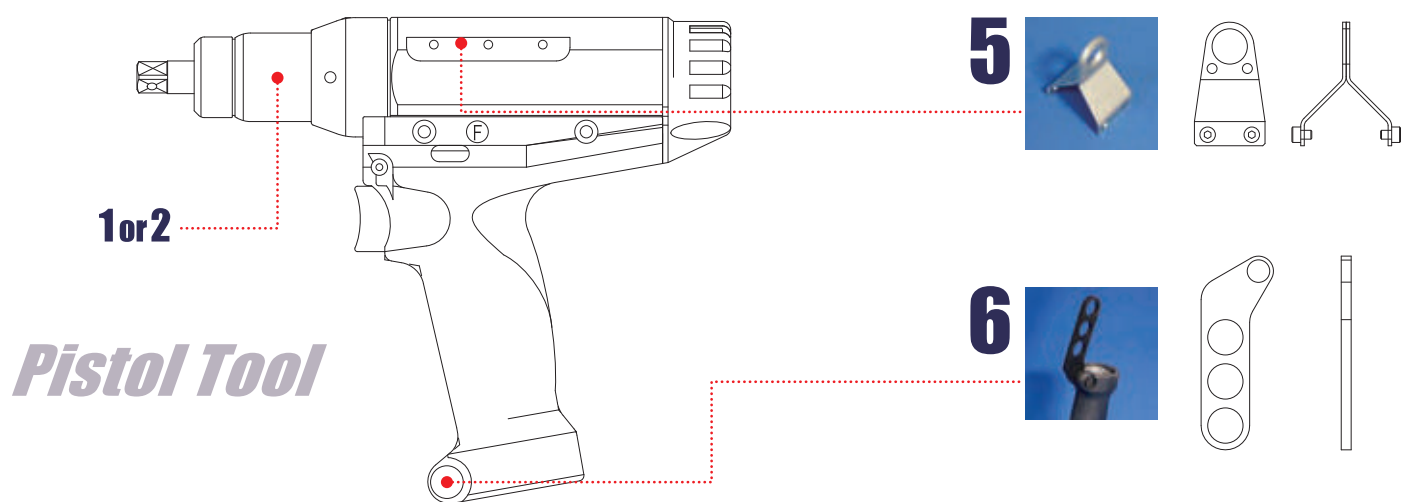

Pistol Tool

#	Product Name	Size	Model	Usage
1	Hanging Hook	φ40	HFA-TF01	Angle Tool under 60Nm, Straight Tool under 40 Nm
		φ52	HFA-TF02	Angle Tool over 80Nm, Straight Tool over 80 Nm
2	Hanger Arm	φ40	HFA-TF04	Angle Tool under 60Nm, Straight Tool under 40 Nm
		φ52	HFA-TF05	Angle Tool over 80Nm, Straight Tool over 80 Nm
3	Hanging Hook Grip End		HFA-TF06	Commonly used for Angle and Straight tool
4	L Shape Hanging Hook Grip End		HFA-TF07	Commonly used for Angle and Straight tool
5	Hanging Hook Grip End		HFA-TF08	Pistol Type Tool
6	Upside down hanger		HFA-TF09	Pistol Type Tool
-	L Shape Handle		HFA-HA01	Straight tool under 40 Nm
-	Torque Reaction Plate		HFA-RP01	Straight tool under 40 Nm

Accessories/Carbon Torque Tube

Reduces Torque Reaction / Improves ergonomics of manual fastening.

- Usability
 - Dampens torque reaction and vibration.
 - Smooth movement with carbon material.
 - Tighten with one hand.
- Compact
 - Built-in balancer design.



Sample Application

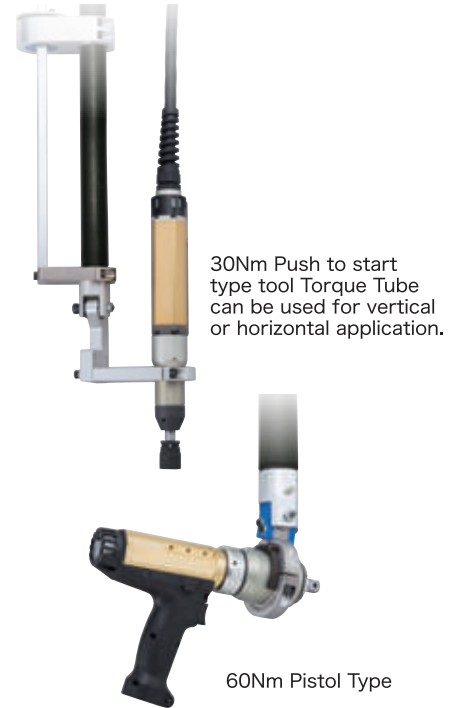

Part #	Max Torque [N·m]	Stroke [mm]	Max Hanging Weight [kg]	Weight [kg]
TTR060-4100-04	60	1,000	2.0~4.0	5.5
TTR200-4100-05	200	1,000	3.0~5.0	6.0

Specifications and designs of the products are subject to change without notice due to improvements.

Accessories/Arm

Swivel Arm



Sliding Arm

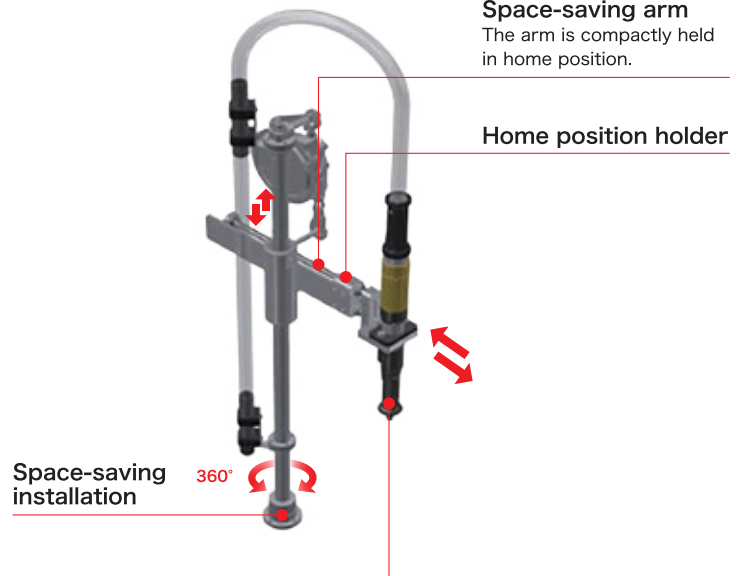

Selectable grips



Features

Flexibility

Multi Press Control

Parameter settings : Max 128
 Sequence settings : Max 64
*Expansion unit is required.

Data Manageability

CF Card

Store press operation result, curve and program.

Ethernet

High-speed data communication

Accuracy

Distance display
 1/1000 digit

Ultra slow press control
 0.01 mm/s

System Configuration (Conceptual diagram)

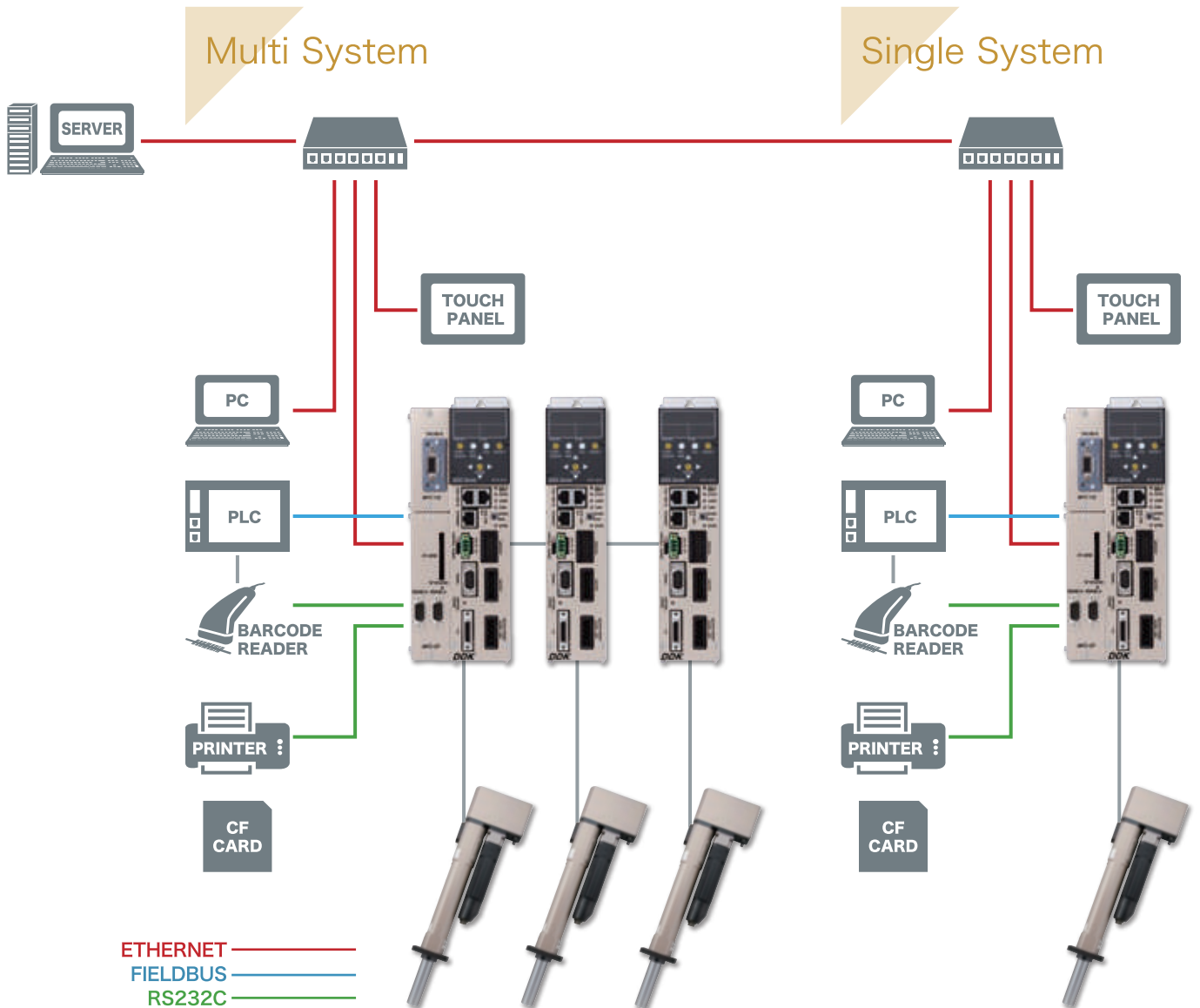

*"Multi Unit" not required in Multi system.

Application

AVAILABLE PRESS METHODS FOR VARIOUS APPLICATIONS

Load Method

Run to the target load, judge upper & lower limit of the load & distance.

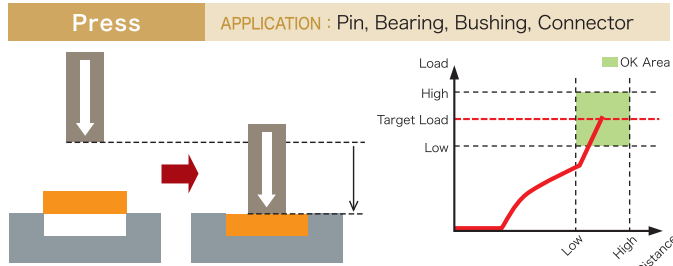

Distance Method

Run to the target distance, judge upper & lower limit of the load & distance.

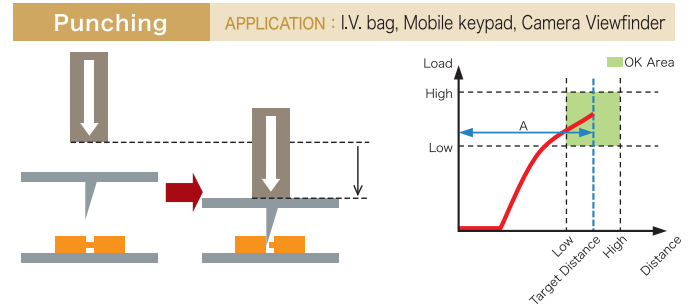

Specified Point Load Detection

Press by target load and judge the higher / lower load and distance. Judge the specified load simultaneously.

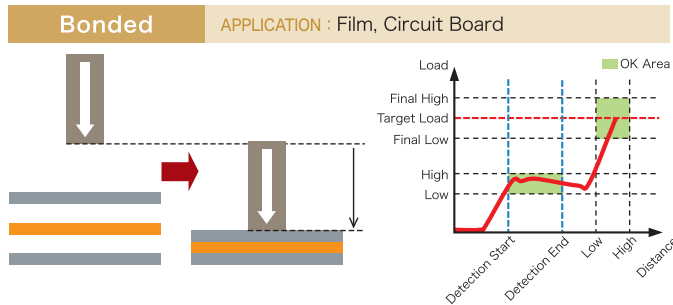

Load Rise Detection and Distance Method

Calculate load rise point within the specified distance area and judge the higher / lower load and distance from this point after pressing the target distance.

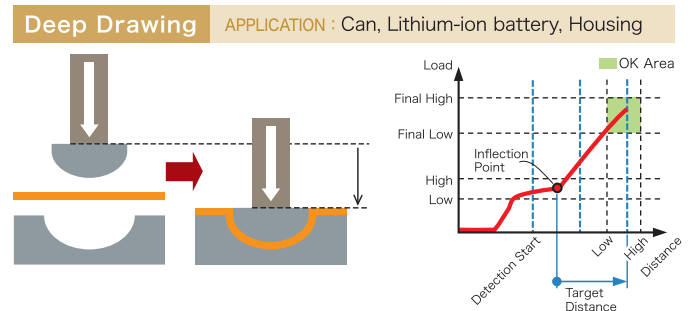

Load Drop Detection

Press by the target load, but servo press stops when it detects the load drop point on pressing and judge higher / lower load and distance.

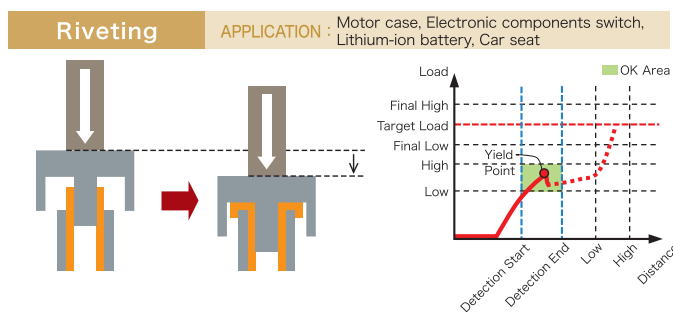

Constant Load Distance Method

Press by the target load with load limit and judge the higher / lower load and distance.

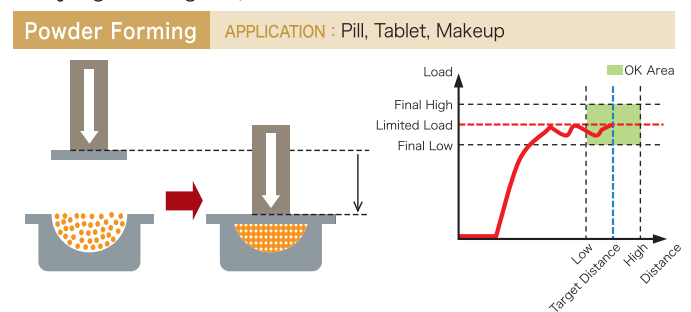

Check Function

Interference Check

The servo press detects an interference check load, and stops pressing at this point, before part damage occurs.

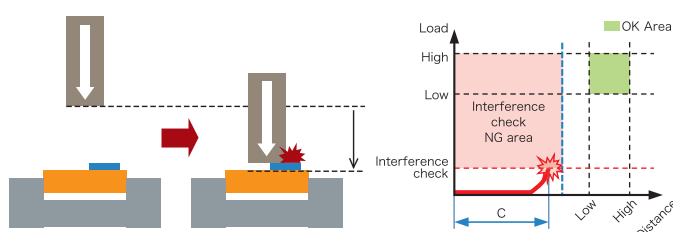

Starting Load Detection

If the starting load is higher than the target load, range can be set to ignore / detect this initial spike.

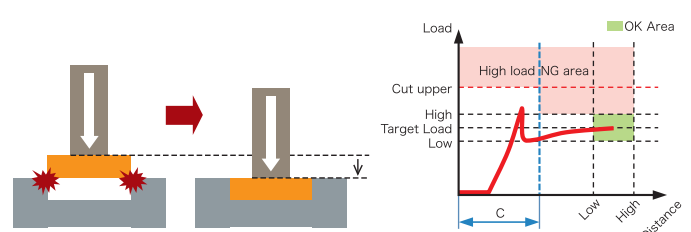

Controller and Expansion Unit

BASE UNIT

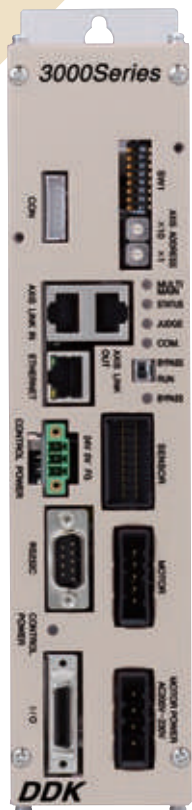

OPTIONAL UNIT



Display

User Friendly Display

- Displays full content with 6 digit / 2 row LED
- Easily operated cursor keys

Option1

Fieldbus I/O Interfaces

Various interfaces for direct PLC I/O & data connections

Option2

Expansion COM Ports and memory

- Compact Flash (CF) for result data
- Expansion RS232C Input / Output ports

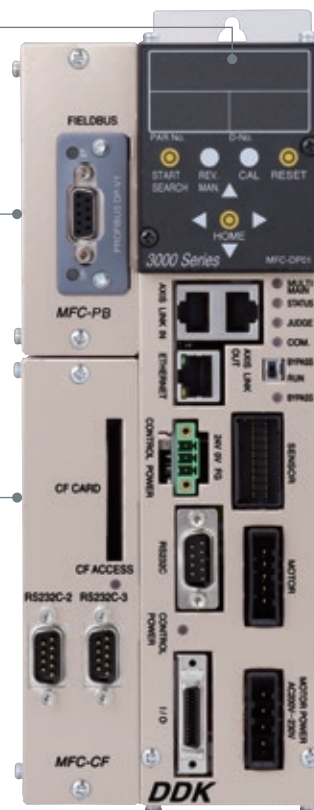

Unit Model	MFC-S024S	MFC-S060S	MFC-S120S
Momentary Max. Peak Current	17.0Arms	42.4Arms	84.8Arms
Transformer Capacity	0.3KVA×spindles	0.8KVA×spindles	4.0KVA×spindles
Input power	3-phase AC200~230V±10% 50/60H		
Control Power	DC24V±10% 0.5A		DC24V±10% 1A
Operating Environment	temperature 0°C~+50°C humidity -below90%RH		
RS232C communication	38400bps (default)/19200bps/9600bps, 1 port		
External analog monitor output	Load analog voltage, Distance pulse, CW/CCW pulse etc.		
Axis Link Communication	Spindle Link Communication Port (connect Max. 32 spindles)		
Ethernet	PC communication port in conformity with IEEE802.3(100BASE-T)		
Standard I/O Connector	Input : 12	Output : 12	
Fastening Result Data memory	12000 Cycles max	500 last REJECT cycles	
TQ. Curve Memory	Last 100 Curves	Last 100 Reject Curves	

Controller	Tool Model Supported	Power Consumption (Max Rating)	display	option1	option2
MFC-S024S	DPM-***H1-*	80W			
MFC-S060S	DPS-***R3-*	200W			
	DPR-***R3-*	200W			
	DPL-***R3-*	200W			
MFC-S120S	DPS-***R4J-*	1.5kW	MFC-DP01	Fieldbus Industrial Ethernet	CF
	DPS-***R5-*	3.0kW			
	DPR-***R4J-*	1.5kW			
	DPL-***R4J-*	1.5kW			
	DPL-***R5-*	3.0kW			

Optional model	Description	Unit Type
MFC-DT-S	Expansion I/O (Input:32ch / Output:32ch)	
MFC-CC-S	CC-Link V2	
MFC-DN-S	DeviceNet	
MFC-PB-S	PROFIBUS DP-V1	Option1
MFC-EN-S	EtherNet/IP	
MFC-PN-S	PROFINET IO	
MFC-EC-S	EtherCAT	
MFC-CI-S	CC-Link IE Field	
MFC-CF-S	Compact Flash card, Expansion RS232C(2ports)	Option2



Adjustment and maintenance of the Servo Press at start-up

Operational Display Model: 17P-19011



Press Tools



DPS SLIM LINE PRESS

Standard Type (F-Type:Fitting)

Model	Max Rated Load [kN(ton)]	Max Continuous Load [kN(ton)]	Maximum Speed [mm/s]	Standard Stroke [mm]	Weight [Kg]	Total Length [mm]	Applicable Controller	Manufacturable Stroke [mm]
DPS-051R3-20FB	5 (0.51)	1.8 (0.18)	333	200	16.4	575	MFC-S060S	300/400/500
DPS-101R3-20FB	10 (1.02)	2.7 (0.28)	222	200	16.4	575	MFC-S060S	300/400/500
DPS-301R4J-20FB-CE	30 (3.06)	10.8 (1.1)	250	200	36.5	660	MFC-S120S	300/400/500/600
DPS-501R4J-20FB-CE	50 (5.1)	13.5 (1.38)	200	200	62	760	MFC-S120S	300/400/500/600
DPS-501R5-20FB	50 (5.1)	21.5 (2.19)	200	200	74	760	MFC-S120S	300/400/500/600
DPS-801R4J-20FB-CE	80 (8.16)	18 (1.84)	150	200	98	855	MFC-S120S	300/400/500/600
DPS-102R5-20FB	100 (10.2)	32 (3.26)	133	200	110	855	MFC-S120S	300/400/500/600
DPS-202Y5-20FB	200 (20.39)	73 (7.44)	120	200	218	1030	MFC-GSC *1	300/400/500/600

High Power Type (P-Type: Bonding)

Model	Max Rated Load [kN(ton)]	Max Continuous Load [kN(ton)]	Maximum Speed [mm/s]	Standard Stroke [mm]	Weight [Kg]	Total Length [mm]	Applicable Controller	Manufacturable Stroke [mm]
DPS-051R3-20PB	5 (0.51)	5 (0.51)	88	200	17	575	MFC-S060S	300/400/500
DPS-101R4J-20PB-CE	10 (1.02)	10 (1.02)	200	200	21	575	MFC-S120S	300/400/500
DPS-301R4J-20PB-CE	30 (3.06)	30 (3.06)	66	200	38	660	MFC-S120S	300/400/500/600
DPS-501R5-20PB	50 (5.1)	50 (5.1)	53	200	79	760	MFC-S120S	300/400/500/600
DPS-801R5-20PB	80 (8.16)	80 (8.16)	40	200	116	855	MFC-S120S	300/400/500/600
DPS-102R5-20PB	100 (10.2)	100 (10.2)	32	200	116	855	MFC-S120S	300/400/500/600
DPS-202Y5-20PB	200 (20.39)	200 (20.39)	40	200	222	1030	MFC-GSC *1	300/400/500/600

*1 Please contact us.



DPM MINI PRESS

Model	Max Rated Load [kN(ton)]	Max Continuous Load [kN(ton)]	Maximum Speed [mm/s]	Standard Stroke [mm]	Weight [Kg]	Total Length [mm]	Applicable Controller
DPM-050H1-10P	0.5 (0.05)	0.49 (0.05)	130	100	4.0	270	MFC-S024S
DPM-011H1-10F	1 (0.1)	0.49 (0.05)	130	100	4.0	270	MFC-S024S



DPL LOW PROFILE PRESS *1

Model	Max Rated Load [kN(ton)]	Max Continuous Load [kN(ton)]	Maximum Speed [mm/s]	Standard Stroke [mm]	Weight [Kg]	Total Length [mm]	Applicable Controller	Manufacturable Stroke [mm]
DPL-101R3-20FB	10 (1.02)	2.6 (0.27)	222	200	19	411	MFC-S060S	300
DPL-301R4J-20FB-CE	30 (3.06)	10.8 (1.1)	250	200	35	479	MFC-S120S	300
DPL-501R4J-20FB-CE	50 (5.1)	13.5 (1.38)	200	200	49	527	MFC-S120S	300
DPL-102R5-20FB-CE	100 (10.2)	32 (3.26)	133	200	96	603	MFC-S120S	300

*1 DPL tool require the detent mechanism



DPR STRAIGHT PRESS

Model	Max Rated Load [kN(ton)]	Max Continuous Load [kN(ton)]	Maximum Speed [mm/s]	Standard Stroke [mm]	Weight [Kg]	Total Length [mm]	Applicable Controller
DPR-101R3-30FB	10 (1.02)	2.5 (0.25)	238	300	31	1005	MFC-S060S
DPR-301R4J-30FB-CE	30 (3.06)	8.3 (0.84)	250	300	52	1045.5	MFC-S120S
DPR-501R4J-30FB-CE	50 (5.1)	10.4 (1.06)	200	300	104	1148	MFC-S120S

Model information

DPS - 301 - R4J - 20 - FB - CE - P

Series name	Max load	Stroke*1	Tool type	CE option	Limit sensor polarity
DPS Slim Type	011 1kN 501 50kN	10 100mm 40 400mm	FB Standard Type	CE Compatible	- NPN P PNP
DPM Mini Type	051 5kN 801 80kN	20 200mm 50 500mm	PB High Power Type	- Non-compatible	
DPL Low Profile Type	101 10kN 102 100kN	30 300mm 60 600mm			
DPR Straight Type	301 30kN 202 200kN				

*1 Some strokes cannot be manufactured depending on the series. Some strokes are made to order. Please contact us for details.

DPS PRESS Wiring Diagram

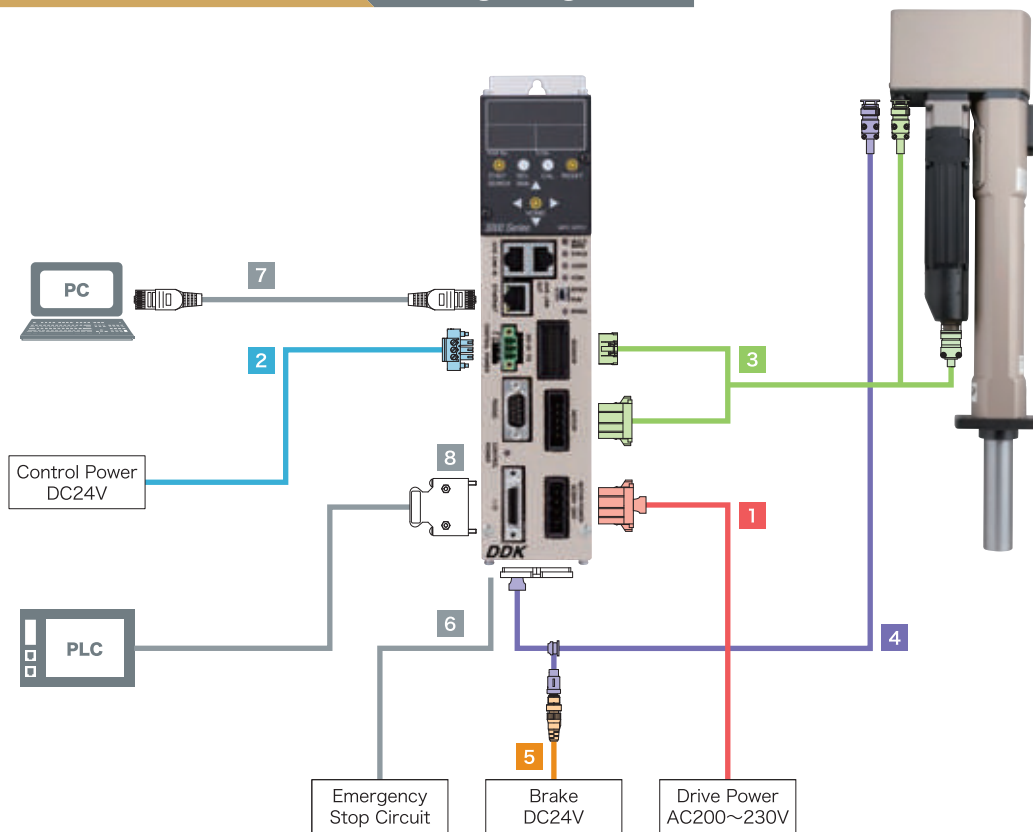

MINI PRESS Wiring Diagram

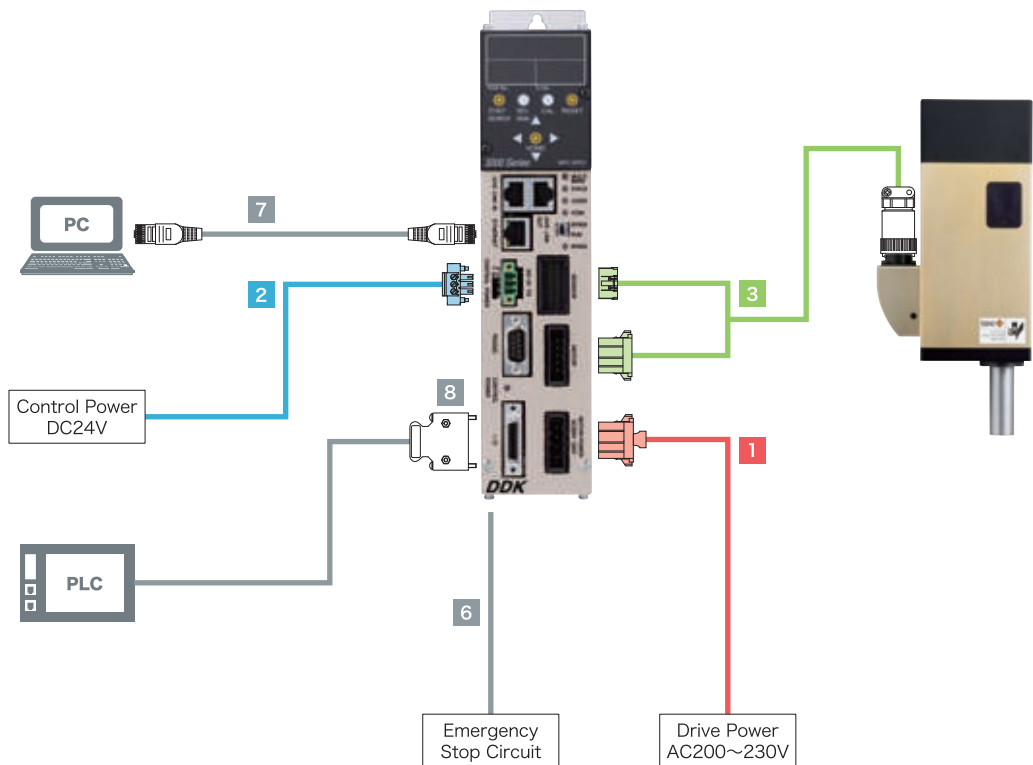

*This diagram is for reference, Details refer to manual.

DPL PRESS/DPR PRESS

Wiring Diagram

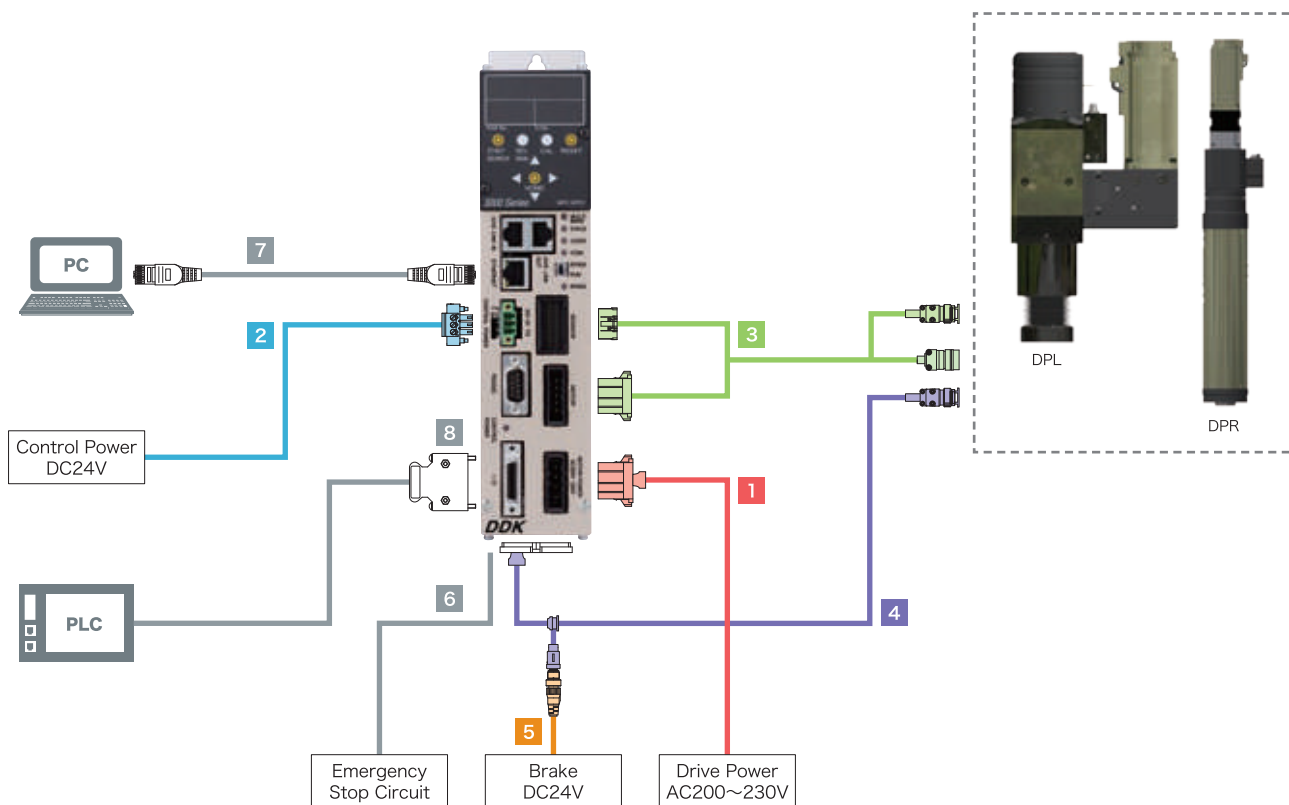

Cable Applicable Table

No.	Cable Name	DPS-***R3*	DPS-***R4*	DPS-***R5*	DPM-***H1*	DPR-***R3*	DPR-***R4*	DPL-***R4*	DPL-***R5*	Model	Standard length	Remarks
1	Drive Power Cable for MFC-S024S / S060S	■			■	■				C15-D1-M*	2m/5m	Included in controller.
	Drive Power Cable for MFC-S120S		■	■			■	■		C15-D2-M*	2m/5m	Included in controller.
2	Control Power Cable	■	■	■	■	■	■	■		C30-DC1-M*	(2m)	
	Control Power Connector	■	■	■	■	■	■	■		MC1.5/3-STF-3.81		Included in controller.
	Tool Cable for RM1 / RM2 / RM3	■				■	■			C30-FM1-M*	5m/10m	
	Tool Cable for RM4J		■					■		C30-FW4-M*	5m/10m	
3	Preamplifier & Resolver Cable for RM5			■				■		C30-PR5-M*	5m/10m	
	Motor Cable for RM5			■				■		C15-M1-M*	5m/10m	
	Tool Cable for H1				■					C30-FH1-M*	5m/10m	
4	Limit Sensor & Brake Cable	■	■	■		■	■	■		C30-L3-M*	5m/10m	
5	Brake Cable	■	■	■		■	■	■		C15-B3-M1-U	1m	
	Extension Brake Cable	■	■	■		■	■	■		C15-EB3-M*-U	5m/10m	
6	Stop Signal Cable	■	■	■	■	■	■	■		C30-XA1-M*	(2m)	
	Stop Signal Connector	■	■	■	■	■	■	■		MC1.5/2-STF-3.81		Included in Fieldbus Option1
7	ETHERNET Crossover(For PC, touch panel connection)	■	■	■	■	■	■	■		C30-UL1-M*	3m	For direct connection.
	ETHERNET Straight(For PC, touch panel connection)	■	■	■	■	■	■	■		C30-UL2-M*	3m	For connecting through Hub.
	Standard I/O Cable	■	■	■	■	■	■	■		C30-SU1-M*	2m	
8	Standard I/O Connector	■	■	■	■	■	■	■		10126-3000PE		Included in controller.
	Expansion I/O Cable	■	■	■	■	■	■	■		C30-SE1-M*	2m	
9	Axis Communication Cable	■	■	■	■	■	■	■		C15-A3-M*	0.3m/1m	
10	Axis Communication Connector	■	■	■	■	■	■	■		C30-AL2		
11	RS232C Communication Cable	■	■	■	■	■	■	■		C30-TU1-M*	3m	

*Cable length except standard is available as optional.

Various Functions

Protection Functions

Self-Diagnosis	Offset Load Check	Press / Controller Mismatch Check	Servo Motor Protection *1
----------------	-------------------	-----------------------------------	------------------------------

Pressing Functions

Target load stop	Target distance stop	Target load holding	Target distance holding	Monitoring Position, Load, Time
Continuous position accuracy ±0.01mm *2	No. of parameter Single 32 Multi 128	Load Range 0.25kN~200kN	Maximum Connecting tool NO. 32	Maximum Sequence NO. 64

*1 Over current, Over load, Over voltage, Temperature etc. *2 Depends on Press model

User Console Software

WINDOW'S® BASED CONFIGURATION, PROGRAMMING AND MONITOR SOFTWARE (DSP-UC-N)

- Easy graphical set up
- Result data collection & storage
- Load/distance curve data to Excel data
- Press Sequence Functions

Press Setting Display

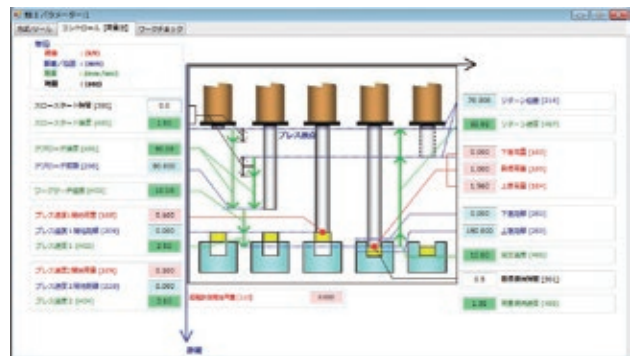

I/O Monitor

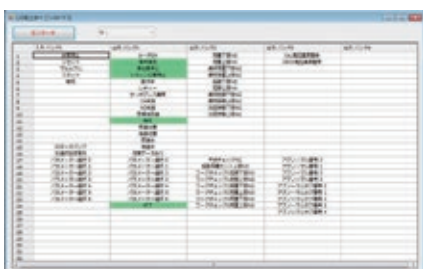

Load Curve Display

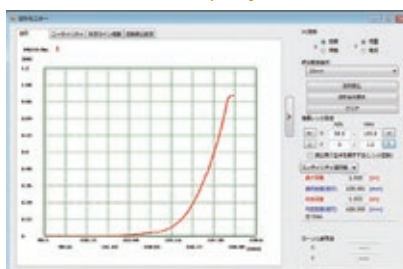

Press Result Display

NO.	DATE	TIME	LOAD	DISTANCE	STATUS	REMARKS
1	2010-07-18 09:00	09:00	100.0	10.0	OK	
2	2010-07-18 09:05	09:05	100.0	10.0	OK	
3	2010-07-18 09:10	09:10	100.0	10.0	OK	
4	2010-07-18 09:15	09:15	100.0	10.0	OK	
5	2010-07-18 09:20	09:20	100.0	10.0	OK	
6	2010-07-18 09:25	09:25	100.0	10.0	OK	
7	2010-07-18 09:30	09:30	100.0	10.0	OK	
8	2010-07-18 09:35	09:35	100.0	10.0	OK	
9	2010-07-18 09:40	09:40	100.0	10.0	OK	
10	2010-07-18 09:45	09:45	100.0	10.0	OK	
11	2010-07-18 09:50	09:50	100.0	10.0	OK	
12	2010-07-18 09:55	09:55	100.0	10.0	OK	
13	2010-07-18 10:00	10:00	100.0	10.0	OK	
14	2010-07-18 10:05	10:05	100.0	10.0	OK	
15	2010-07-18 10:10	10:10	100.0	10.0	OK	
16	2010-07-18 10:15	10:15	100.0	10.0	OK	
17	2010-07-18 10:20	10:20	100.0	10.0	OK	
18	2010-07-18 10:25	10:25	100.0	10.0	OK	
19	2010-07-18 10:30	10:30	100.0	10.0	OK	
20	2010-07-18 10:35	10:35	100.0	10.0	OK	
21	2010-07-18 10:40	10:40	100.0	10.0	OK	
22	2010-07-18 10:45	10:45	100.0	10.0	OK	
23	2010-07-18 10:50	10:50	100.0	10.0	OK	
24	2010-07-18 10:55	10:55	100.0	10.0	OK	
25	2010-07-18 11:00	11:00	100.0	10.0	OK	

DISTRIBUTION NETWORK

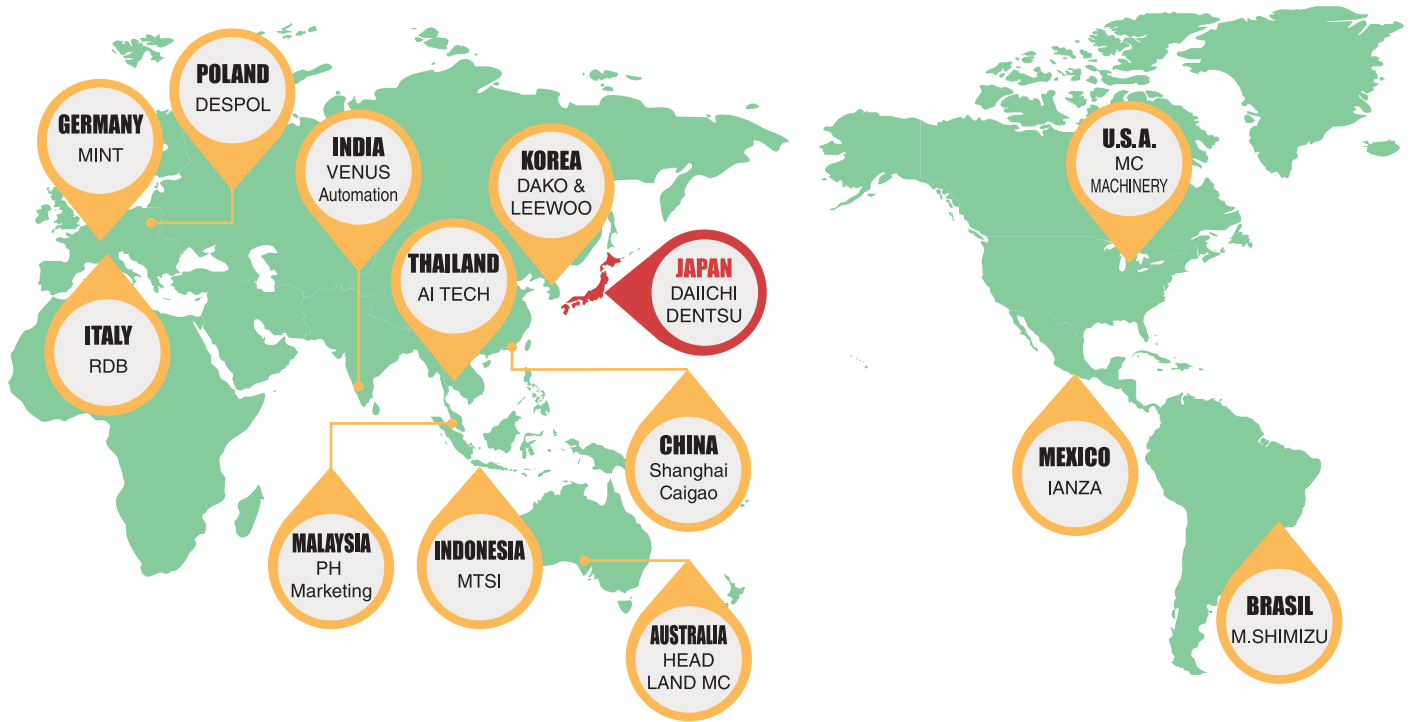

JQA-QMA13393



ELECTRICAL ASSEMBLY TOOLS
DAI-ICHI DENTSU LTD.

NUTRUNNER / HAND-HELD TOOL / SERVO PRESS



Headquarters 1-54-1, Shimoishihara, Chofu-City, Tokyo 182-0034 Japan TEL : +81-424-40-1465 FAX : +81-424-40-1436
Kani Plant 690-1 Omori, Kani-City, Gifu, 509-0238 Japan TEL : +81-574-62-5865 FAX : +81-574-62-3523

E-mail : ddksales@daiichi-dentsu.co.jp

www.daiichi-dentsu.co.jp