



PHARMA MACHINERIES

TABLET COATING SYSTEM



RIDDHI PHARMA MACHINERY LTD.

CIN: U33112GJ1995PLC028504

Manufacturer & Exporters of Pharmaceutical Machineries

MUMBAI OFFICE: Om-shivam soc., Tarun Bharat Bldg. No.2, Opp. Cigarette Factory, Sahar Road, Andheri (East), Mumbai - 400 099. Maharashtra, India Tel.: +91-22-28321332 / 28382479
Mobile: +91- 9821018579 / 9969994187 Email: hkshah@riddhipharma.com / riddhipharma@yahoo.com
Web : www.riddhipharma.com / www.riddhipharma.net

REGD. OFFICE & FACTORY : Riddhi Estate, Gulab Nagar, Opp. AEC, Amraiwadi, Ahmedabad - 380026. India.



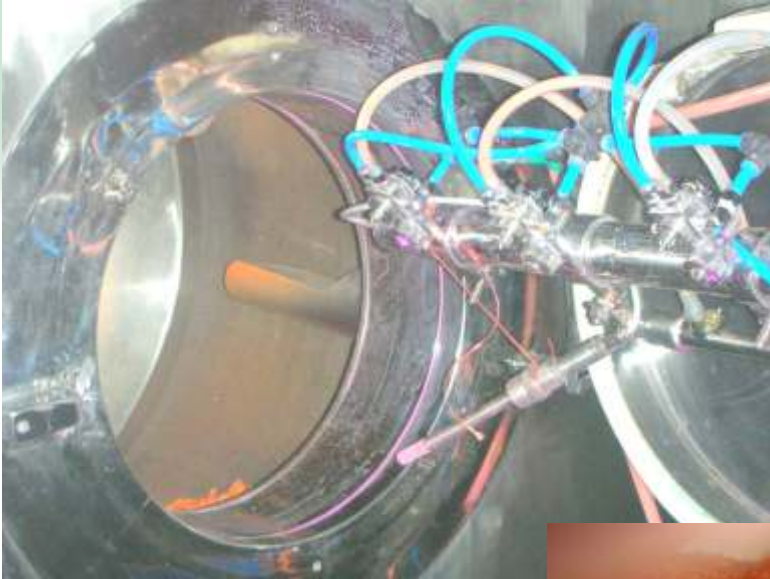



RIDDHI AUTO COATER /
TABLET COATING SYSTEM
MACHINE GENERAL ARRANGEMENT DRAWING

Riddhi Pharma Machinery Ltd. (India)

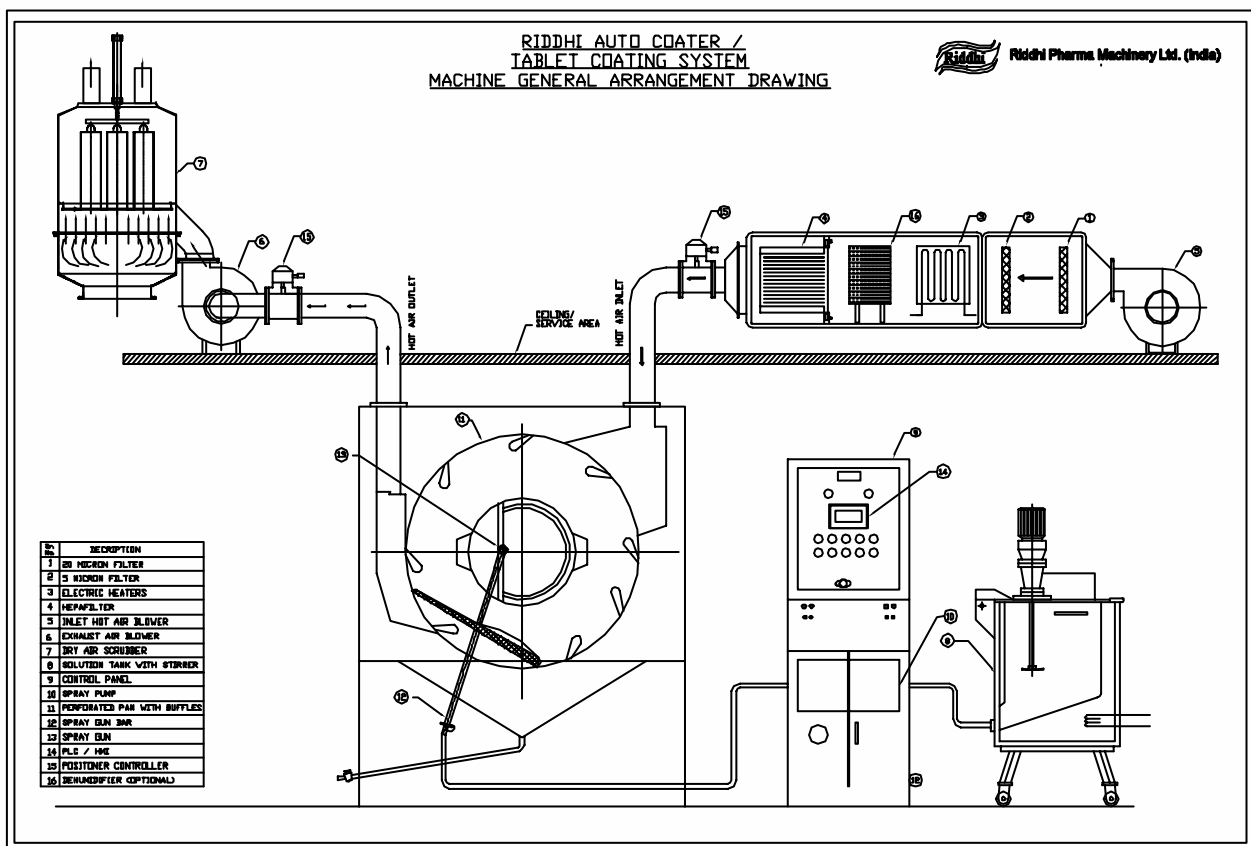

NO.	DESCRIPTION
1	DI MESH FILTER
2	WINDER FILTER
3	ELECTRIC HEATERS
4	HEPAFILTER
5	INLET HOT AIR BLOWER
6	EXHAUST AIR BLOWER
7	DRY AIR SCRUBBER
8	SOLUTION TANK WITH STIRRER
9	CONTROL PANEL
10	SPRAY PUMP
11	PERFORATED PAN WITH BUFFLES
12	SPRAY DRUM
13	SPRAY GUN
14	PLC / HMI
15	POSITIONER CONTROLLER
16	DEHUMIDIFIER (OPTIONAL)



RIDDHI PHARMA MACHINERY LTD.

CIN: U33112GJ1995PLC028504

Manufacturer & Exporters of Pharmaceutical Machineries

MUMBAI OFFICE: Om-shivam soc., Tarun Bharat Bldg. No.2, Opp. Cigarette Factory, Sahar Road, Andheri (East), Mumbai - 400 099. Maharashtra, India. Tel.: +91-22-28321332 / 28382479

Mobile: +91- 9821018579 / 9969994187 Email: hkshah@riddhipharma.com / riddhipharma@yahoo.com

Web : www.riddhipharma.com / www.riddhipharma.net

REGD. OFFICE & FACTORY : Riddhi Estate, Gulab Nagar, Opp. AEC, Amraiwadi, Ahmedabad - 380026. India.





AUTO COATER TECHNICAL SPECIFICATION

Technical specification	Models					
	660mm (24")	940mm (37")	1070mm (42")	1220 mm (40")	1525mm (60")	1675mm (66")
Working Capacity-KG (Considering bulk density 0.97 gm/cc)	10-20	40-70	60-100	80-150	200-350	350-500
Pan Mouth Diameter –MM	250	380	380	400	520	520
Pan Speed – RPM	5-15	2-10	2-10	2-10	2-10	2-8
Main Drive FLP Motor – HP	1	2	2	3	5	10
Hot Air Inlet Blower – HP	1	2	3	5	7.5	10
Hot Air Fan Capacity – CFM	350	1300	1600	2500	4000	5500
Steam Consumption in (Kg/Hr) At Pressure (Bar)	15-20 2-4	40-60 2-4	50-70 2-4	80-100 2-4	120-140 2-4	16-180 2-4
Compressed air (CFM) At pressure 6 (Bar)	20	30	30	55	95	110



RIDDHI PHARMA MACHINERY LTD.

CIN: U33112GJ1995PLC028504

Manufacturer & Exporters of Pharmaceutical Machineries

MUMBAI OFFICE: Om-shivam soc., Tarun Bharat Bldg. No.2, Opp. Cigaratte Factory, Sahar Road,
 Andheri (East), Mumbai - 400 099. Maharashtra, India Tel.: +91-22-28321332 / 28382479
 Mobile: +91- 9821018579 / 9969994187 Email: hkshah@riddhipharma.com / riddhipharma@yahoo.com
 Web : www.riddhipharma.com / www.riddhipharma.net

REGD. OFFICE & FACTORY : Riddhi Estate, Gulab Nagar, Opp. AEC, Amraiwadi, Ahmedabad - 380026. India.

