

Industrial Visual Inspection Machine



Alluminium Cap Sealing Machine, Fully Automatic Type PFS Machine, Industrial Visual Inspection Machine, Injectable Dry Powder Filling Machine, Weight Based Rejection Injectable Liquid Filling Machine, etc.



ALLUMINIUM CAP SEALING MACHINE

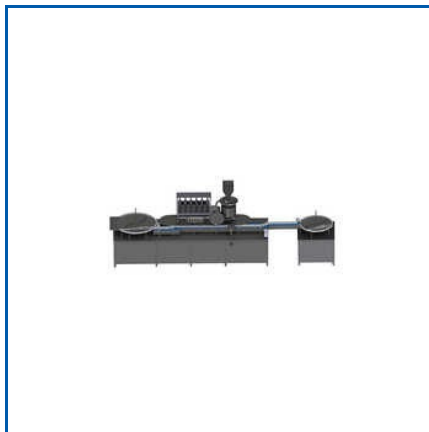

WEIGHT BASED REJECTION INJECTABLE LIQUID FILLING MACHINE



FULLY AUTOMATIC TYPE PFS MACHINE

About Us

Medfill Pharmatech is committed to redefining injectable pharmaceutical machinery standards through precision engineering, smart automation, and unrivaled functionality. As a supplier and producer, the firm provides a range of specialized machines that meet the demanding needs of injectable manufacturing. Fully automatic type pfs machine, weight-based rejection injectable liquid filling machine, aluminium cap sealer machine, injectable dry powder filling machine, and industrial visual inspection machine are carefully crafted to be compliant with GMP, to ensure sterility assurance, and for efficient operation. Through the incorporation of advanced technologies like real-time quality inspection, weight checking, and smart rejection systems, the equipment not only reduces product loss but also provides consistent accuracy in high-speed production environments. From compact footprint designs to easy-to-use HMI interfaces, every aspect reflects user-centric innovation. Machines are made easy to insert into existing lines, with provision for varying container formats and rapid format changeover capabilities that make operations across various production batches more convenient. With remote technical support, preventive maintenance, and certified cleaning processes, the life of each machine is optimized and downtimes are significantly reduced.

Backed by advanced contamination prevention mechanisms and programable recipe management systems, all equipment is the pinnacle of engineering perfection and industry regulation. We offer the highest level of data integrity, audit-ready reports, and multi-language operator training to enable manufacturers to confidently meet global requirements.

Key Facts

No of Staff	12
Year of Establishment	2024
No of Production Lines	1
OEM Service Provided	No

Our Products



**Weight Based
Rejection Injectable**



**Injectable Dry Powder
Filling Machine**



**Fully Automatic Type
PFS Machine**



**Industrial Visual
Inspection Machine**



ADDRESS

Block No. T, Shade No. 8, Opp
Vatva Railway Station, Sml Mill
Compound, Ahmedabad,
Gujarat, India (382445).



EMAIL

sales@medfill.in



MOBILE

+918758472947



WEBSITE

www.medfillpharmatech.com

KEY PERSONNEL
Rajnikant Solanki
(M,D)