

VIEW - 'BB'
INSTRUMENT SIDE
4 NOS. 12.5mm. DIA MOUNTING HOLE.

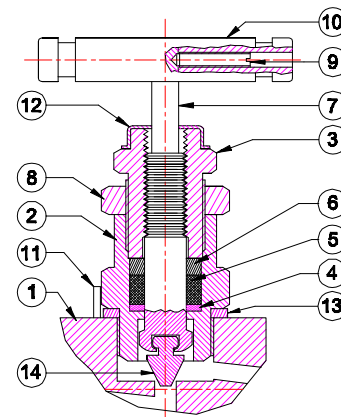

BONNET ASSEMBLY

S.NO.	DESCRIPTION	QTY.	MATERIAL
14	NON ROTATING VEE TIP	5	A564-630
13	WASHER	5	A479-316
12	DUST CAP	5	PLASTIC LD.
11	LOCK PIN	5	A479-316
10	HANDLE	5	A479-316
9	GRUB SCREW	5	STEEL
8	LOCK NUT	5	A479-316
7	SPINDLE	5	A479-316
6	PACKING WASHER	5	A479-316
5	PACKING	5	PTFE/GRAFOIL
4	WASHER	5	A479-316
3	GLAND RETAINER	5	A479-316
2	BONNET	5	A479-316
1	BODY	1	A479-316

MATERIAL OF CONSTRUCTIONS

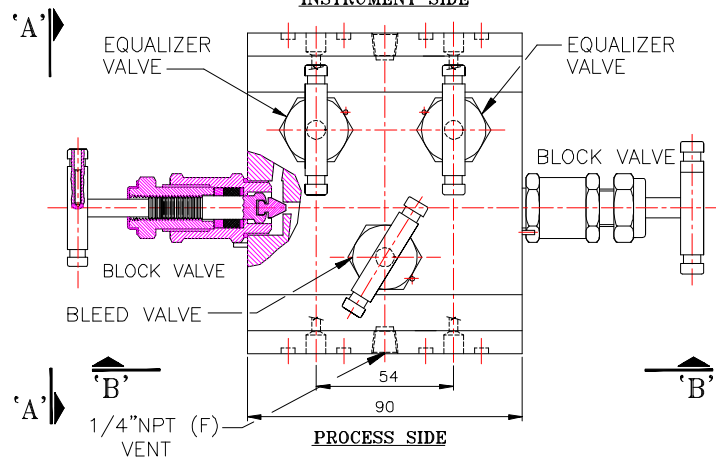

PLAN

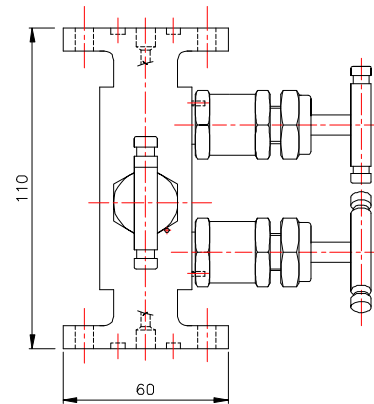

VIEW - 'AA'

TECHNICAL DATA					
Seat	Pr. Rat.	Temp.Rat.		Cv	Orifice
METAL SEAT	6000 PSI (41300 kpa)	PTFE -20 to 250° F (-29° to 121°C)	GRAFOIL -20 to 600° F (-29° to 315°C)	0.52 max.	4.8 mm.

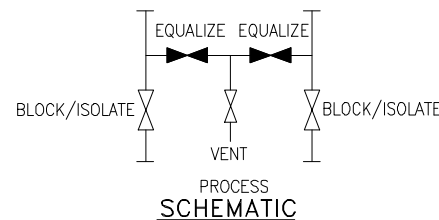

PIONEER INDUSTRIES

5-VALVE MANIFOLD FLANGE TO FLANGE CONNECTION DESIGNED FOR CONNECTING SYSTEM IMPULSE LINES & TRANSMETERS. THIS MANIFOLD CONSISTS FLANGED END OUTLET CONNECTION ON 54mm (2-1/8") CENTERS AND OF TWO EQUALIZER VALVE ,TWO BLOCK VALVES & ONE VENT VALVE.

FEATURES :

316 S.S. BODY CONSTRUCTION FOR SUPERIOR CORROSION RESISTANCE. NON ROTATING VEE TIP PREVENTS GALLING & PROMOTES REPETITIVE SHUT-OFF. OPTIONAL GRAPHOIL PACKING MATERIAL IS AVAILABLE FOR HIGH TEMP. RATING 1000°F @6000 PSI

TESTING:

PNEUMATIC TEST:- EACH VALVE IS TESTED WITH NITROGEN AT 100 Psi IN ACCORDANCE WITH MSS-SP-61 FOR SEAT & PACKING LEAKAGE.

HYDRO TEST:- PERFORMED WITH PURE WATER IN ACCORDANCE WITH MSS-SP-61. BODY TESTED AT 1.5 TIMES & SEAT LEAKAGE TESTED AT 1.1 TIMES OF THE WORKING PRESSURE.

DESIGN STANDARD :

PRESSURE & TEMPERATURE RATING ARE SELECTED FROM ANSI B16.34 STANDARD CLASS VALVES BASED ON ANSI B16-CLASS 2500 OPTIONAL SOUR GAS SERVICE CONFIRMS TO NACE STD. MR-01-75

REV.	DESCRIPTION	BY	DATE
REVISION			
TITLE:- 5 VALVE MANIFOLD (FLANGE TO FLANGE)			
DRN.	SCALE - NTS.		
CHD.	RJS	DATE - 02/01/2010	
APPD.	DRG.NO.: 5VM-SS-8-H	RO	

PIONEER INDUSTRIES
ISO 9001 - 2008

NOTE:-1) DIMENSIONS ARE IN MM.FOR REFERENCE ONLY,SUBJECT TO CHANGE.
2) APPROXIMATE WEIGHT= 3.94 KG.