



BUSINESS RELATIONSHIP

CUSTOMER SATISFACTION

PRODUCT QUALITY

CRAFTING METALS WITH PRECISION

*Since 1990*

We " **Akshar Engineering Works** " are based in Vadodara, Gujarat, India established in 1990. Initially, our company started with manufacturing customized dies and tools for various industry sectors along with multiple Industrial & Automotive Radiator Components. Gradually with the backing of latest manufacturing technologies, we have expanded our scope of work into manufacturing of Electric Panel Enclosure, Metal Storage Cabinets, Structural Fabricated Frames and Panel, Perforated Sheets, Infrastructure Machine Enclosures, Sheet Metal Fabrication, CNC Fibre Laser Cutting Services, CNC Punching Services, Architectural Design Products, customised Storage Solutions and diversified sheet metal components.

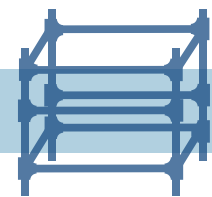
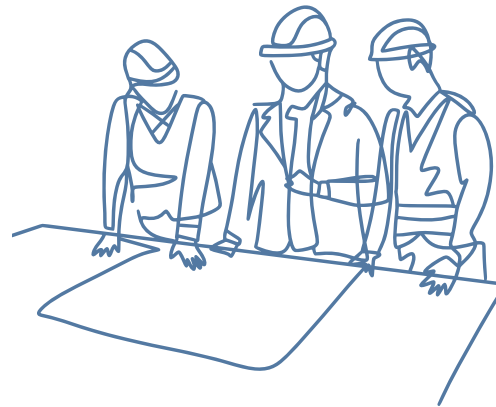

*Each product is well engineered in sync with the industry norms.*





# CORE VALUES

## OUR CORE VALUES

-  COMMITMENT
-  INTEGRITY
-  TRUST
-  KAIZEN
-  TEAM WORK

*Through our sincere intentions we invest time, effort and energy to provide ultimate customer satisfaction.*

*Building relationships through Honesty And Transparency with our employees, clients and suppliers.*

*Trust Is Our Currency, And We Invest It in Success of our business partners.*

*Continuous improvement of processes to achieve enhanced product Quality.*

*Together We Create, Innovate, And Thrive towards legacy of sustained performance.*

*This is how we serve you.*

Customer satisfaction is of paramount importance to us and we strive for betterment in every aspect such as product design, functionality, performance & durability by performing **QA/QC** checks at every process stages by our Quality Control engineers.

A thorough understanding of customer's requirements helps us to tailor our products and offer customized solutions. So whether it is about meeting high-quality standards or about meeting stringent delivery expectations of our customers, we give our best. All our measuring instruments are precisely calibrated on regular intervals to avoid any non compliance.

QUALITY CONTROL

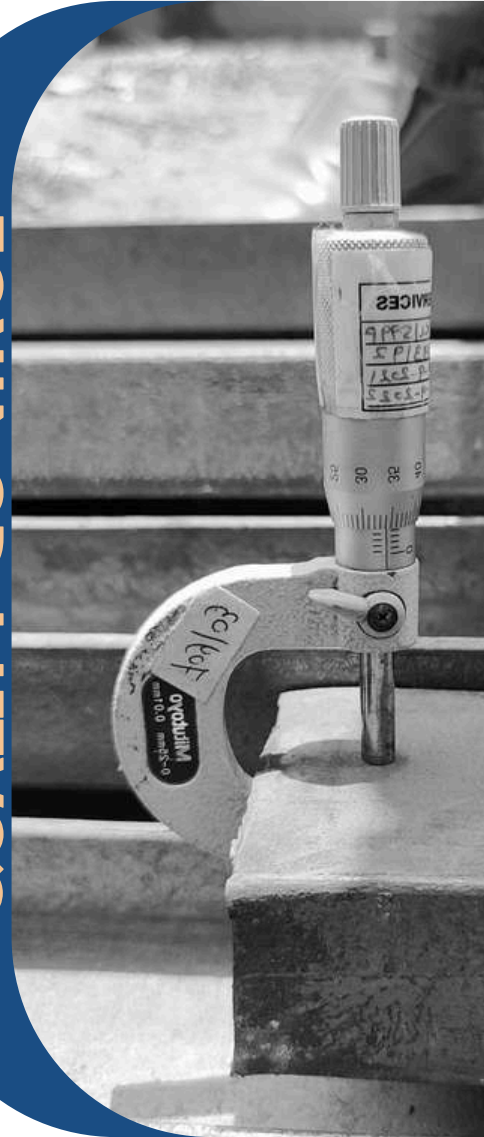

SURFACE PLATE

RIGHT ANGLE PLATE

1 MTR HEIGHT GAUGE



# OUR VALUED CUSTOMERS

## AUTOMOBILE INDUSTRY



BANCO PRODUCTS (INDIA) LIMITED



## FOOD PROCESSING INDUSTRY



## INFRASTRUCTURE INDUSTRY



## ELECTRONICS INDUSTRY



## OIL & GAS INDUSTRY



CIN No. U31909GJ2020PTC118579



# OUR VALUED CUSTOMERS

## AGRICULTURE INDUSTRY



## PRECISION ENGINEERING



## INDUSTRIAL EQUIPMENTS INDUSTRY



PMT MACHINES LIMITED



## HEALTHCARE INDUSTRY

Dr. Udayan's  
LABORATORY



## PAPER PRINTING INDUSTRY



## IT & TELECOM INDUSTRY



## OTHER INDUSTRIES WE SERVE

- ARCHITECTURE INDUSTRY
- REAL ESTATE INDUSTRY
- MUSIC INDUSTRY

# CLIENTELE

# MANUFACTURING TECHNOLOGIES



CNC FIBRE LASER CUTTING MACHINE

( AMADA MACHINERY, JAPAN )

- LCG 3015 AJ (3 KW Laser Power)
- Working Range - 1550 x 3070 mm
- Metals Cut - Fe, SS, Br, Al, Cu, Ti
- Cutting Range upto 19 mm



CNC TURRET PUNCHING MACHINE

( AMADA MACHINERY, JAPAN )

- AE 2510 NT (200 kN Press Capacity)
- Working Range - 1270 x 5000 mm
- Max Sheet Thickness - 3.2 mm
- 58 No of Tool Stations



CNC PRESSBRAKE MACHINE

( ACCURPRESS, U.S.A )

- 510032 - Pressbrake (100 TON)
- CNC Controller (DALEM DA 56)
- Max Working Length - 3050 mm
- 3 Axis Back Gauges

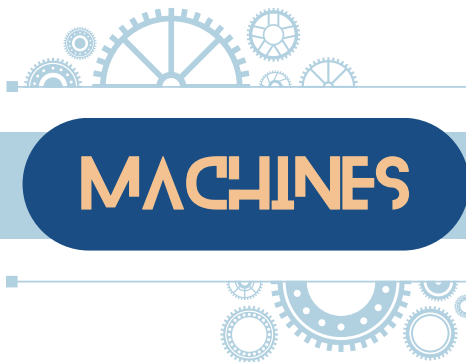

SHEARING MACHINE

( PURVAJ ENGINEERS, INDIA )

- HSVR 2504 (9.5 HP)
- 7" Inch Programmable Controller
- Max Sheet Thickness - 3.2 mm
- Back Gauge with PLC HMI Control



HYDRAULIC PRESS MACHINE (150 TON)

( SHREE HYDRAULIC PRESS, INDIA )



MEASURING INSTRUMENTS

( *Frequently Calibrated Instruments* )



TURRET TOOLS GRINDING MACHINE

( WILSON TOOL INTL, U.S.A )

# MACHINES

MIG WELDING MACHINES

POWER PRESS MACHINES

DRILL MACHINES

TAPPING MACHINES

SURFACE GRINDING MACHINE

CUTTER MACHINES

PNEUMATIC RIVET GUN MACHINE

MAGNETIC DRILL MACHINE

PNEUMATIC NUTSERT GUN MACHINE

HAND GRINDER MACHINES



HYDRAULIC PRESS MACHINE (200 TON)

( SHREE HYDRAULIC PRESS, INDIA )

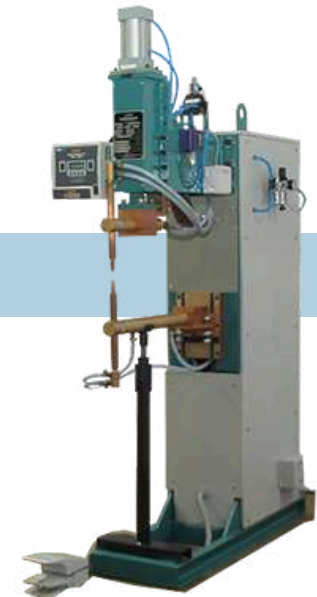
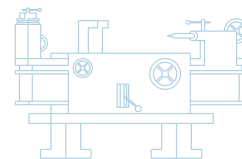

PROJECTION SPOT WELDOR MACHINE

( KRITON WELD EQUIPMENTS, INDIA )



Our facility is aided by modern CAD/CAM/CAE tools to manufacture our customer's parts with ultimate precision and in compliance to their design requirements mentioned as below:

- AutoCAD (2D & 3D Design Software)
- Cam Works (3D CAD Design & Solid Modelling Software - HCL, India)
- AP100 & VPSS (CNC Programming Softwares - Amada, Japan)

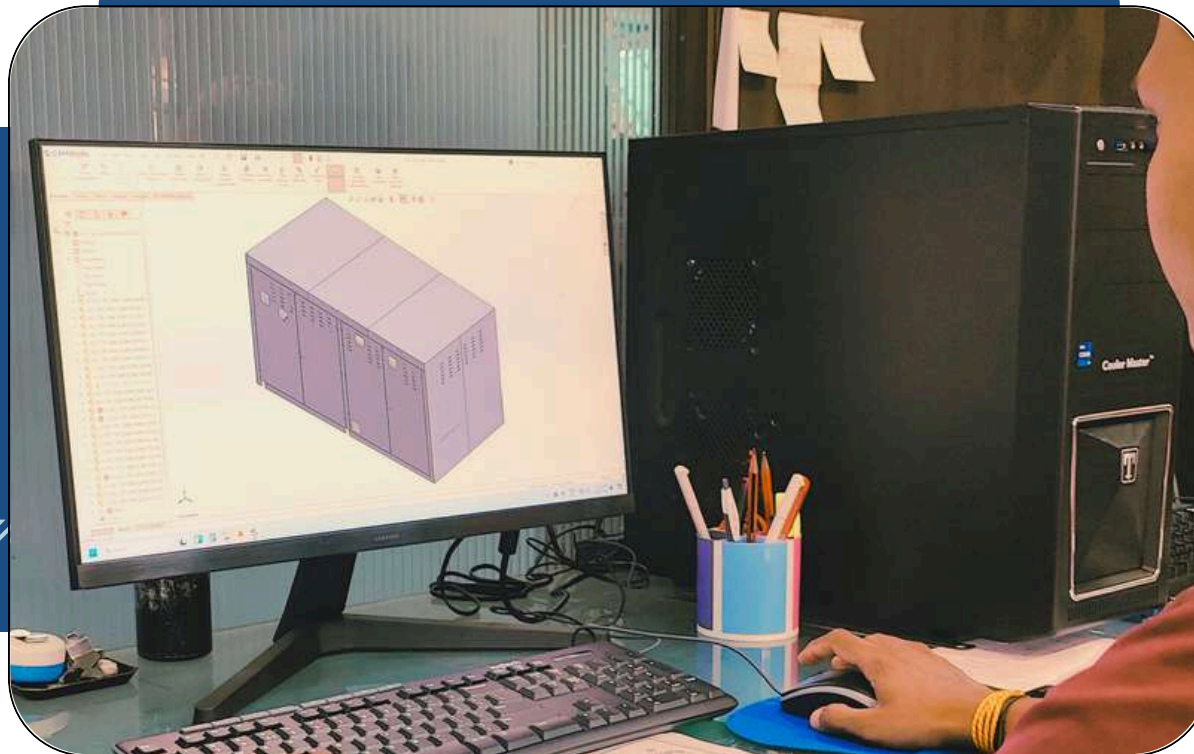
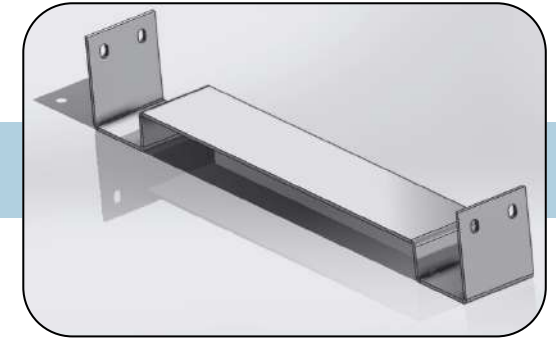

**DESIGN & DEVELOPMENT**

# PROCESS

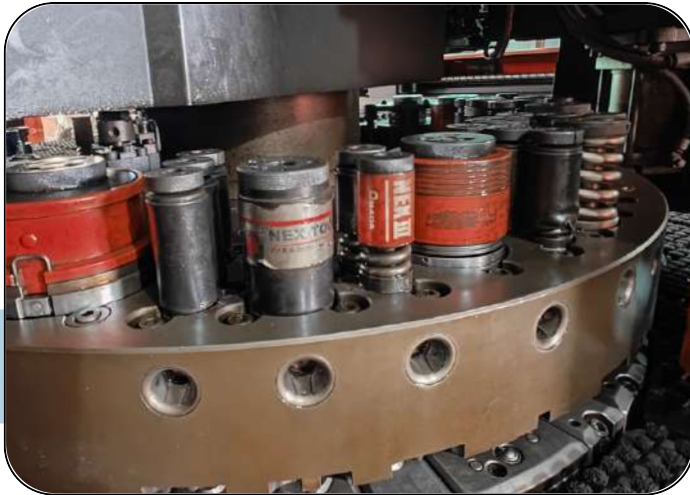

CNC TURRET PUNCHING SERVICES

- Accurate punching process done with precision with variety of tools available.
- High speed punching of perforated parts.
- Multiple shapes and designs can be punched for large qty.



- Precise cutting and premium surface finish.
- Cuts complex shapes & designs and eliminates tooling cost.
- Rendered by trained professionals.

CNC FIBRE LASER CUTTING SERVICES

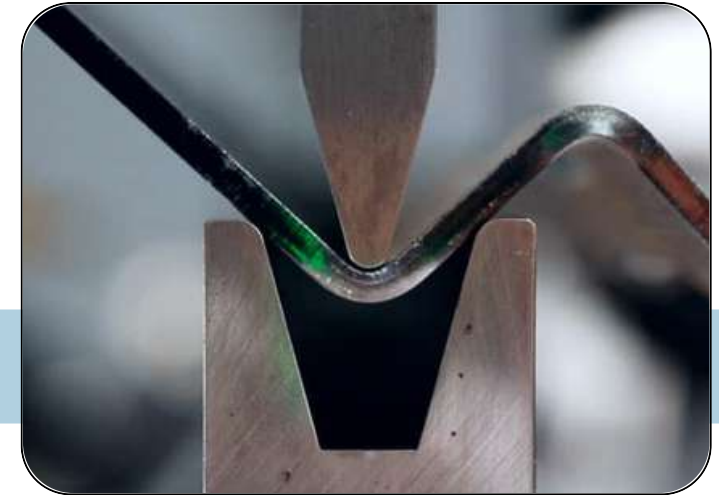

CNC BENDING SERVICES

- CNC programmed bending process with accuracy.
- Critical bending parts can be processed with high efficiency.
- Excellent finish with zero defects.

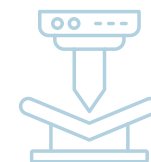

# MANUFACTURING PROCESSES

MS, SS & ALU FABRICATION SERVICES



GRINDING PROCESS



PROJECTION SPOT WELDING



DRILLING PROCESS



TAPPING PROCESS





# PRODUCTS WE CRAFT



**AEW**

# CNC LASER CUT PRODUCTS

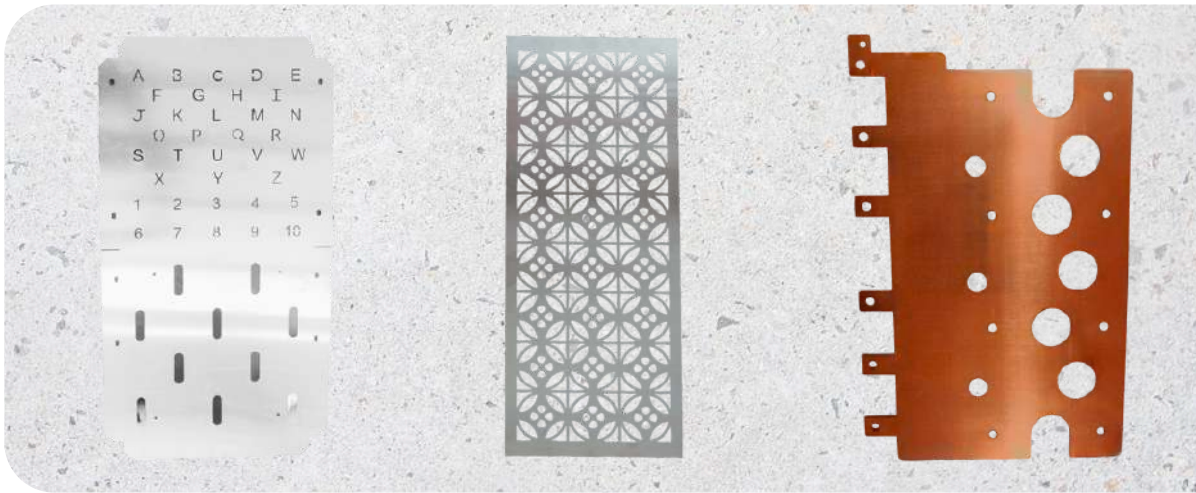

ALUMINIUM LASER CUTTING

MAXIMUM THICKNESS - 15 MM

STAINLESS STEEL LASER CUTTING

MAXIMUM THICKNESS - 15 MM

COPPER LASER CUTTING

MAXIMUM THICKNESS - 12 MM

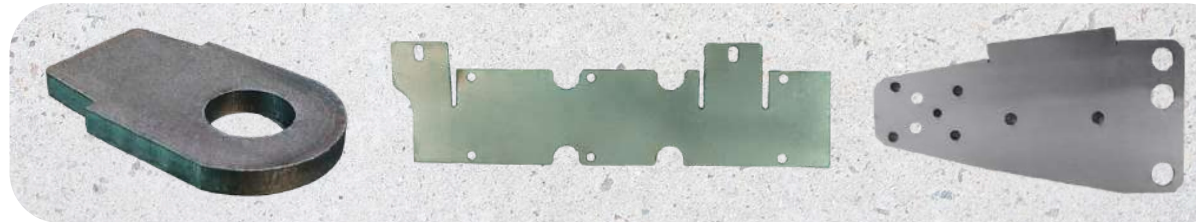

MILD STEEL LASER CUTTING

MAXIMUM THICKNESS - 19 MM

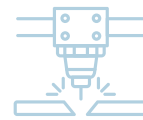

CNC  
LASER  
CUT

BRASS LASER CUTTING

MAXIMUM THICKNESS - 15 MM

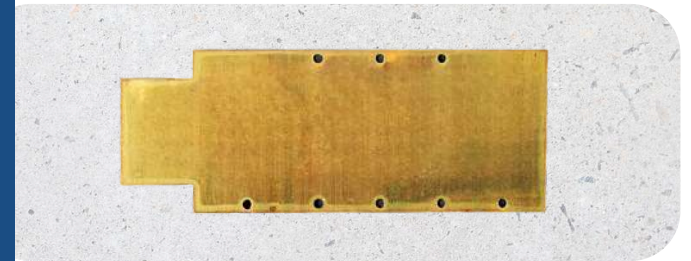

- 3 Kw Fiber laser technology in our CNC laser cut machine helps us achieve high quality edge finish and complex designs can be processed with accuracy.
- We craft out products using raw materials like MS, SS, Aluminium, GI, Brass, Copper & Titanium with the help of achieved Process Range Expansion (P.R.E) in our laser cut machine.



# ELECTRIC METAL ENCLOSURES



ELECTRIC CONTROL PANEL BOX



ALUMINIUM SURGICAL BOX

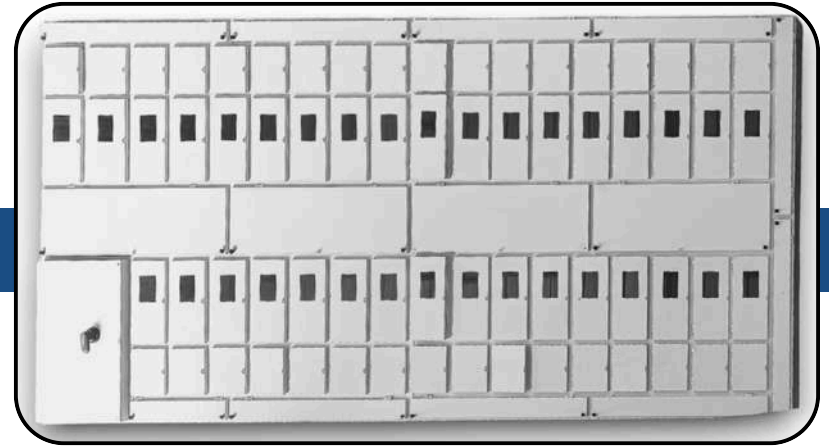

ELECTRIC METER PANEL ENCLOSURE

ELECTRIC PANEL ENCLOSURE



- We manufacture electrical metal enclosures for residential projects, industrial projects and healthcare industry.
- We offer variety of enclosures within electrical sector such as control panel enclosures, meter box enclosures, multi-meter panel enclosures, surgical boxes, electric panel enclosures, etc.



ELECTRIC METER BOX ENCLOSURES



## ELECTRIC METER ENCLOSURES

## METAL PANEL FABRICATION

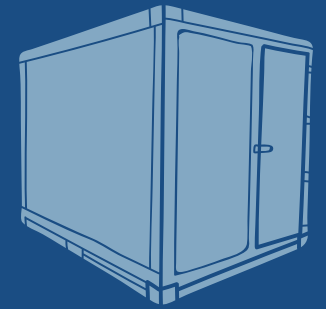

- We can supply different types of Metal enclosures with all fabrication processes done along with final assembly done with all accessories for a final product of the customers.
- We offer Metal panel enclosures for complex Gas Metering Skid Assemblies and Natural Gas Processing & Metering stations.

# MS FABRICATION PRODUCTS

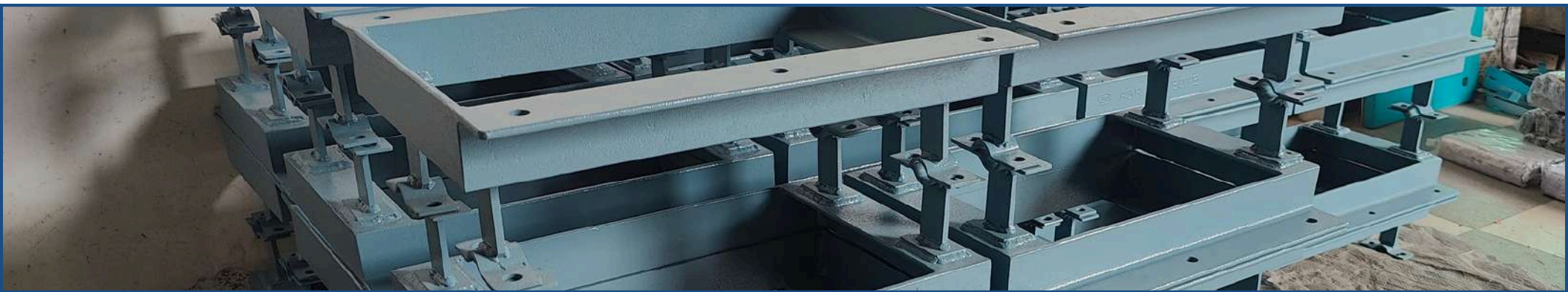

- Our fabrication team has the ability to create a variety of fabricated products, ranging from intricate fine-line sheet metal parts to large assemblies.
- We utilize welding methods such as Mig Welding, Arc Welding, Spot Welding, and Projection Spot Welding.

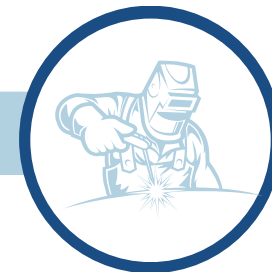
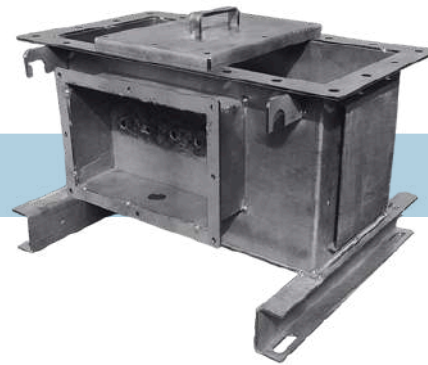

**MILD  
STEEL  
FABRICATION**

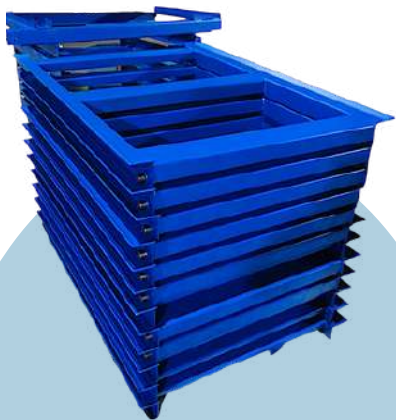

MS SLIDING FRAME ASSLY

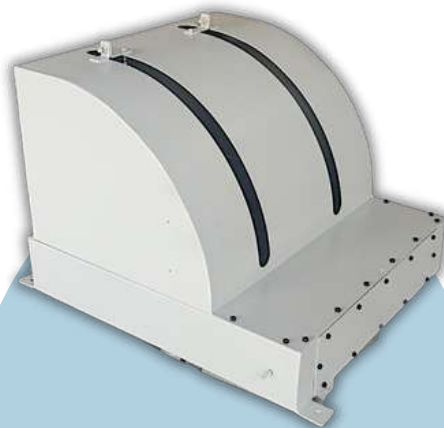

MS SHEET METAL ENCLOSURE

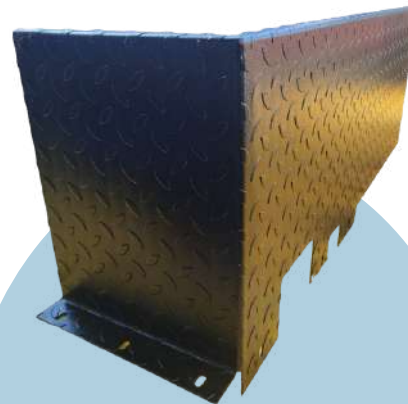

CHEQUERED PLATE FABRICATION



MILD STEEL FABRICATED TABLE



# SS FABRICATION PRODUCTS

SS SLIDING DRAWER BOX



SS SLIDING DRAWER BOX



## STAINLESS STEEL FABRICATION

- Our fabrication team has the ability to create a variety of fabricated products, ranging from intricate fine-line sheet metal parts to large assemblies.
- We utilize welding methods such as Mig Welding, Arc Welding, Spot Welding, and Projection Spot Welding.

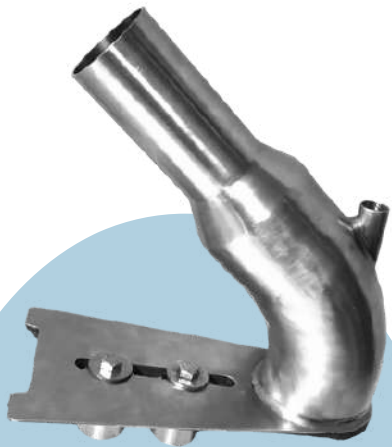

EXHAUST PIPE ASSEMBLY



SS DESIGNER STAND



SS STOOL FOR MULTIPLE USE



SS NEWSPAPER STAND

## STRUCTURES

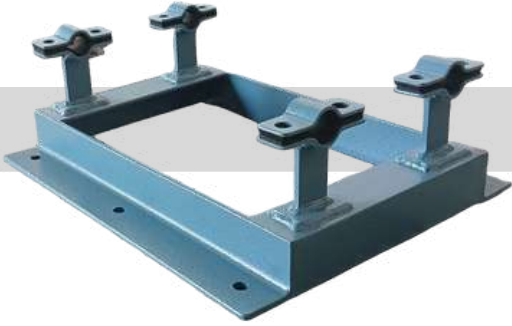

PIPE CLAMP STRUCTURAL FRAME

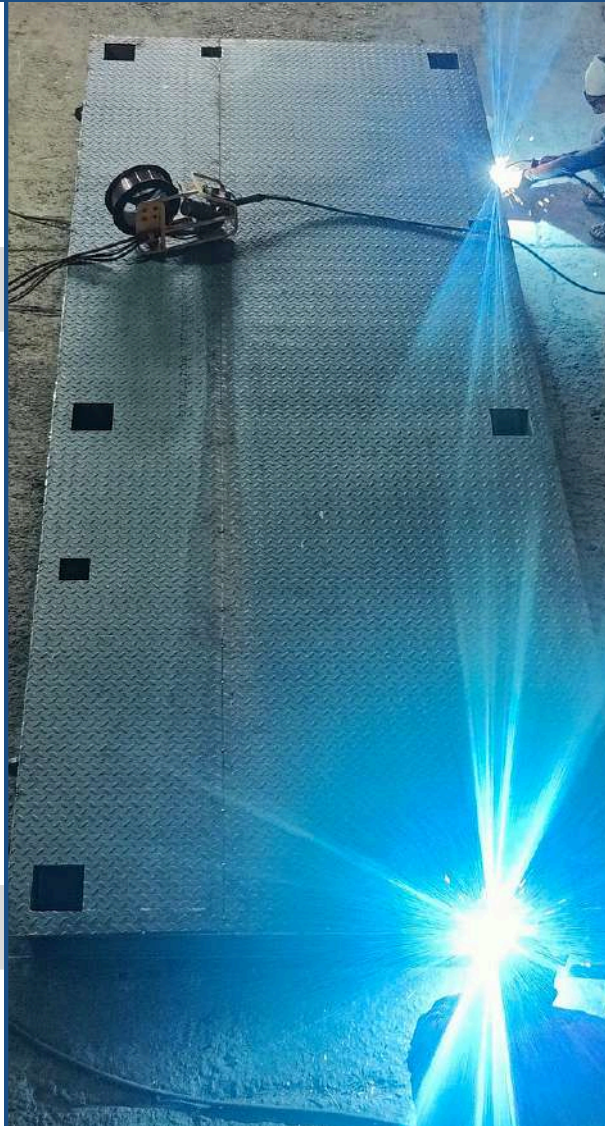

STRUCTURAL FABRICATED FRAMES



We have the ability to produce welding projects ranging from small frames to large structural frame assemblies for various industry uses. Our process involves utilizing multi-dimensional structural channels, angles, flats and other structural sections to build precise frame structures.



# PRECISION SHEET METAL & PRESS COMPONENTS



Using advanced techniques and machinery, the production of sheet metal parts can be achieved with precise dimensions and close tolerances. This meticulous engineering allows for the creation of automotive pressed components that ensure accurate fit, alignment, and operational efficiency within assemblies or structures.

CUSTOMIZED MS PIPE CLAMPS



PRECISION SHEET METAL PARTS

Automotive Components

METAL PRESSED & FORMED PARTS



## PRESSED & FORMED



## RADIATOR PARTS



RADIATOR COWL ASSEMBLY

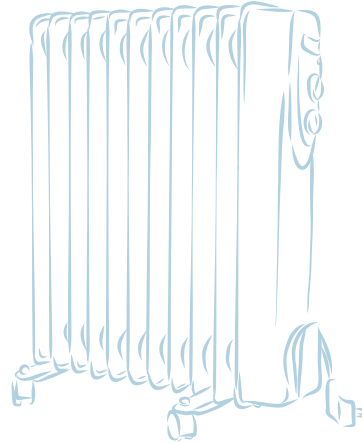

RADIATOR FRAME ASSEMBLY

By incorporating diversity into our manufacturing processes, we are able to manufacture a wide range of sheet metal radiator components, including Radiator Side Frame Assembly, Radiator Cowl Assembly, Radiator Shroud Assembly, Radiator Fan Guard Assembly, and more.



RADIATOR SHROUD ASSEMBLY

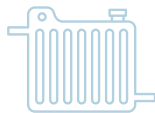

# AUTOMOTIVE RADIATOR COMPONENT & PRODUCTS

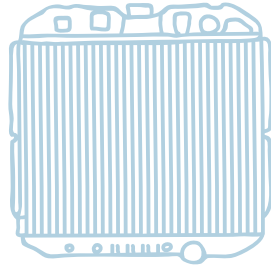
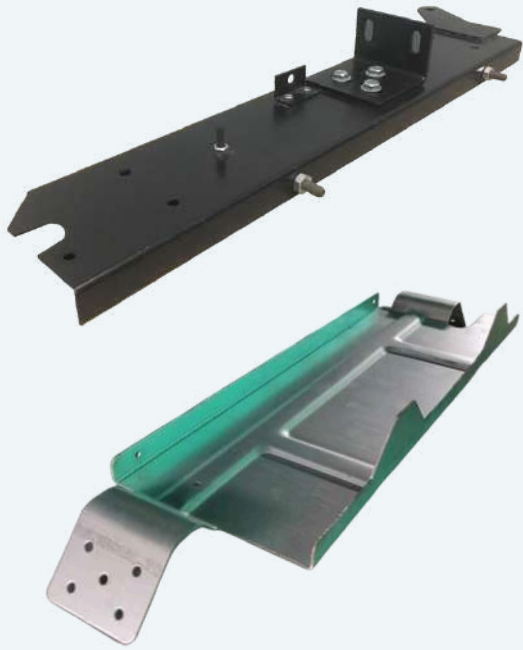

RADIATOR SIDE FRAME ASSEMBLY



RADIATOR FAN GUARD COVER

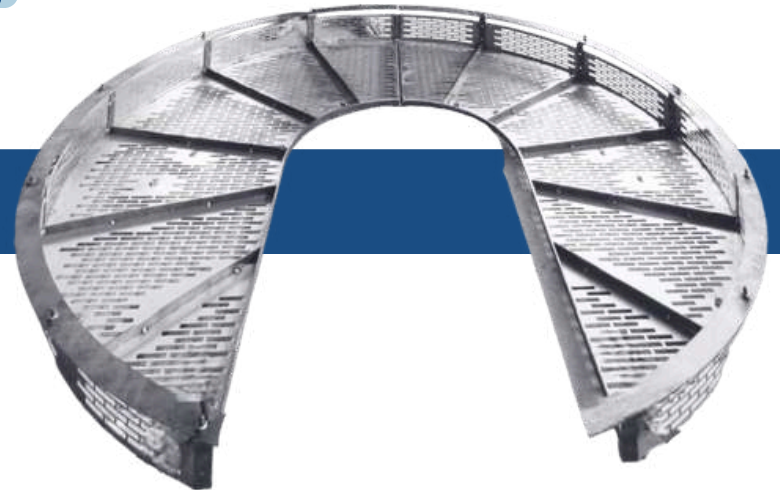
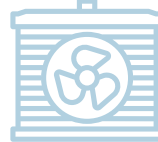
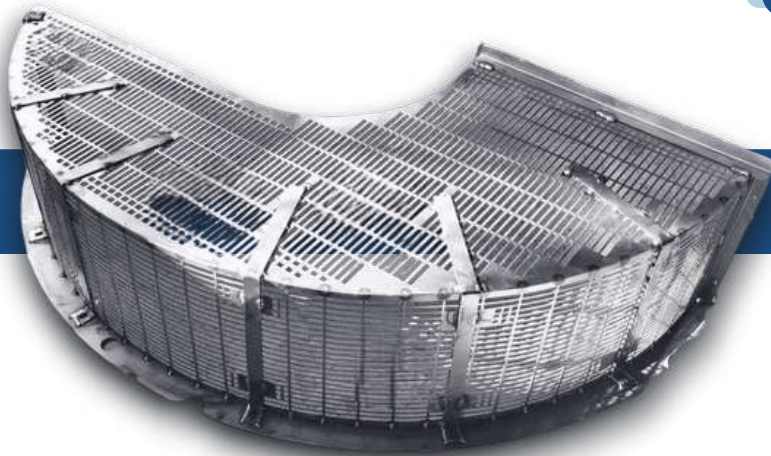

## RADIATOR PARTS

POWDER COATED PERFORATED GRILLS

ALUMINIUM GRILL

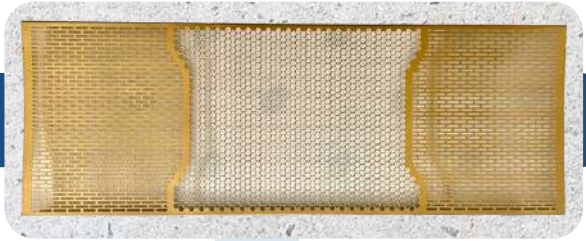

MS DJ GRILL

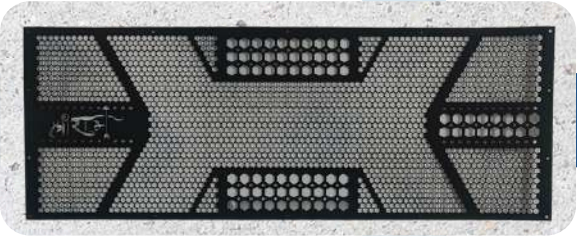

LASER CUT DJ GRILL



SS GRILL

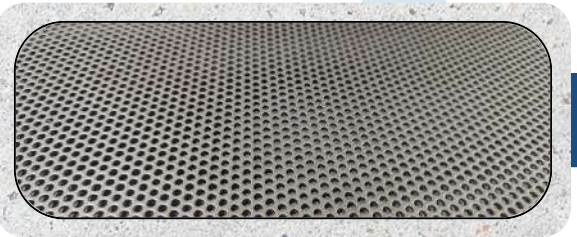

STAINLESS STEEL PERFORATED GRILLS



CUSTOMIZED CABLE TRAYS

MS, GI, ALU & SS CABLE TRAYS

CUSTOM PERFORATION DESIGN

INDUSTRIAL CABLE TRAYS

DESIGNER OFFICE CABLE TRAYS

COMMERCIAL CABLE TRAYS

ARCHITECTURAL CABLE TRAYS

CABLE TRAY FOR ALL INDUSTRIES

- The Turret Punching Machine is tailored to produce perforated patterns with precise gaps, accurate margins, customizable hole spacing, and locator holes with outstanding precision.
- Our product line includes various perforated items such as Industrial & Commercial Cable Trays, DJ Grills, and SS Perforating sheets.

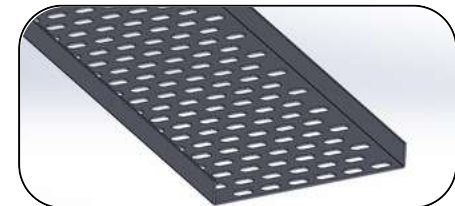

## STORAGE SOLUTIONS

We provide a diverse range of static storage solutions, including file storage cabinets with options for fixed or sliding doors, as well as storage cabinets for organizing any type of items in your office or facility.



GLASS DOOR STORAGE CABINET



*Your Space  
Our Storage Ideas*



SLIDING DOOR STORAGE CABINET



**STORAGE**





EMPLOYEE LOCKER CABINET



EASY ACCESS SHOE STORAGE CABINET



## STORAGE



- Our forte lies in customization, transforming your creative storage concepts into comprehensive storage solutions.
- Our storage solutions can cater to a range of industries, from residential shoe storage cabinets to industrial employee locker cabinets.





## STORAGE

We offer a range of storage solutions including durable heavy-duty and lightweight slotted angle racks tailored for specific storage requirements, as well as fixed stand-type storage racks.

### SLOTTED ANGLE RACKS

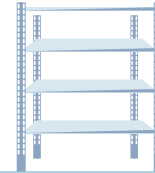

### TYRE STORAGE RACK



*Your Space  
Our Storage Ideas*



ALUMINIUM DESIGNER TABLE



MS & SS MODULAR CUSTOM SWINGS

## SWINGS



ALUMINIUM DESIGNER PLATE

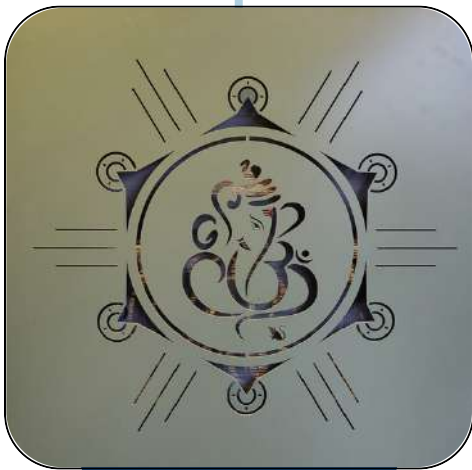

EFFEL TOWER

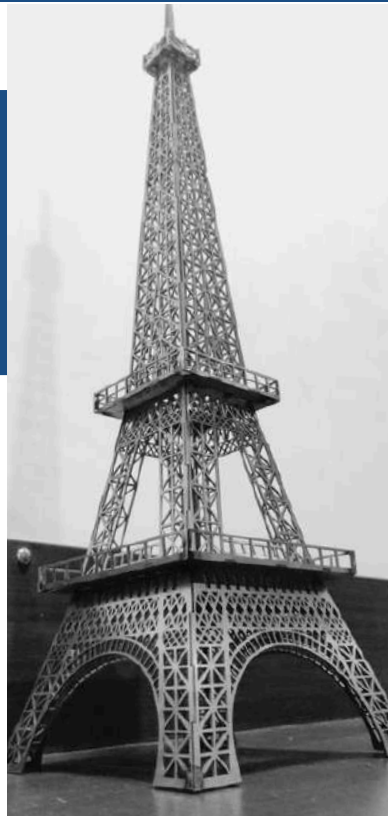

- We offer a variety of customised architectural products that meet the needs of a client.
- We take care of client's requirements right from the design and development stage to final product delivered on site.



PORTABLE BARBEQUE STAND

# ARCHITECTURAL PRODUCTS



HOME ENTRANCE SS DOOR GRILL



SANITIZER STAND

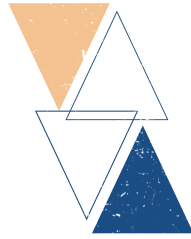

KIDS STUDY CHAIR



CUSTOM DESIGNER TEMPLE



FARM



GATE

# THANK YOU



MANUFACTURING UNIT

CONTACT US



C-1, 517/2, GIDC, MAKARPURA  
- 390010, VADODARA,  
GUJARAT, INDIA

OFFICE : +91 9712246425  
BANKIM : +91 9979349321  
(DIRECTOR)

info@akshareworks.com;  
akshareworks@hotmail.com;  
support@akshareworks.com

[WWW.AKSHAREWORKS.COM](http://WWW.AKSHAREWORKS.COM)

FOLLOW US ON



## CRAFTING METALS WITH PRECISION

*Since 1990*