

Dbios

LIST No. **12**
w.e.f. Apr.15, 2016

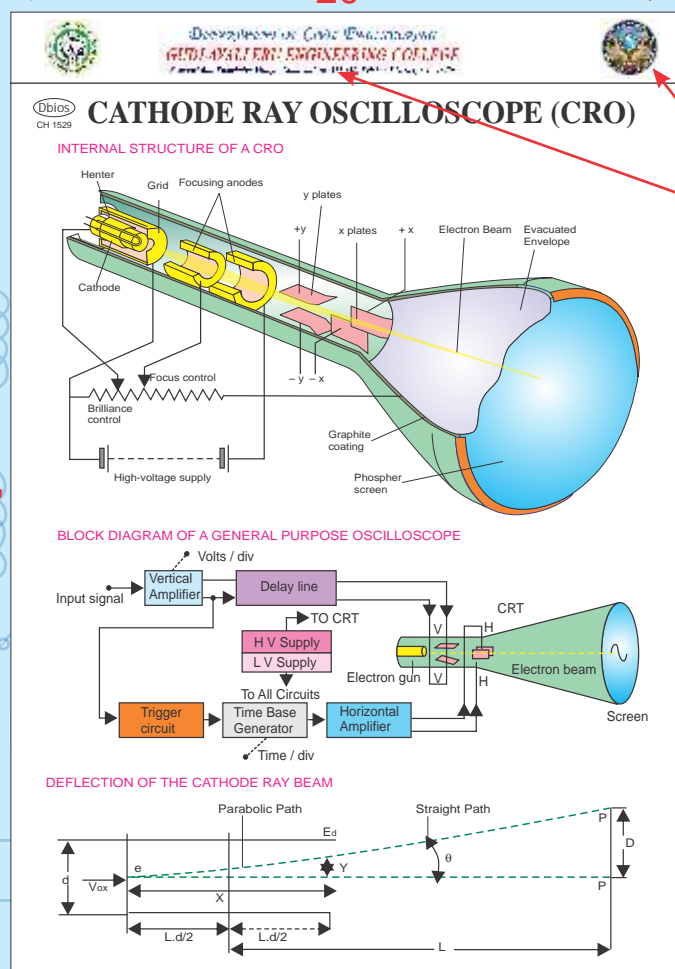

Customised Logo & Name

30"

20"

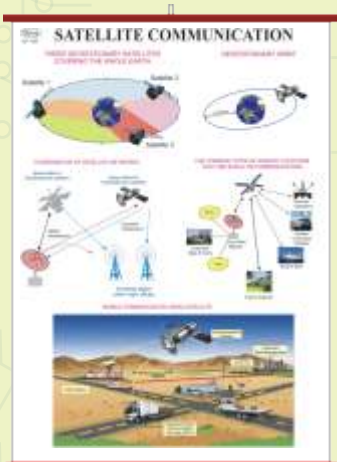

Size: 20"X30"

Laminated and Attached with Strips

Size: 20"X26"



8mm

Laminated and Framed on Board



- DEE 01. D.C. characterization and small signal analysis of transistor in CE configuration.
- DEE 02. Characteristics of JFET (common source) and find the trans-conductance, Gain and Drain Resistance.
- DEE 03. Design of Phase Shift Oscillator using Transistor and error analysis.
- DEE 04. Design of Tuned Amplifier using Transistor, find the cut off frequencies and error analysis.
- DEE 05. Design a Low Pass Filter and High pass filter using op-amp and error analysis.
- DEE 06. To visualize the output in decimal on seven Segment Display for binary as well as BCD inputs.
- DEE 07. To generate Double Side Band Full Carrier Amplitude Modulated Waveform and effect of Modulation Index on the AM envelope.
- DEE 08. To study demodulation of double side band Amplitude Modulated Signal.
- DEE 09. To learn the basic principles of Phase-Locked loop (PLL) and measure its characteristics.
- DEE 10. To generate Frequency Modulated signal and calculate modulation index of FM.
- DEE 11. To measure the characteristic Impedance of symmetrical and Asymmetrical T and Pie Network
- DEE 12. To Study the VI characteristics of SCR and determine the break-over voltage, onstate resistance, holding and Latching current.
- DEE 13. To draw V-I characteristics of a TRIAC in both directions and also in different (1, 2, 3 & 4) modes of operation and determine break over voltages, holding current, latching current and comment on sensitivities.
- DEE 14. To find the error in CRO and Function Generator of your lab
- DEE 15. Design a Second order active Butterworth Low Pass Filter and its error analysis
- DEE 16. To study the Wein Bridge Oscillator, its operation and error analysis.
- DEE 17. For Half Wave and Full Wave Rectifier with capacitor filter, find line and load regulation and ripple factor.
- DEE 18. Design of Class - A amplifier and analysis.
- DEE 19. Design of Class- B amplifier and analysis.
- DEE 20. To find the Op-Amp characteristics practically and then find the error.

KEY FEATURES

- ▶▶ Time Savings For Teachers
- ▶▶ Step By Step Procedure From Start to the end Diagramatically
- ▶▶ Easy To Understand By Students
- ▶▶ Finding the Errors & Then Analysis for that
- ▶▶ Reducing the Errors are the Basic Priority
- ▶▶ Details & Methods for Readings & Then Using Those For Further Calculations

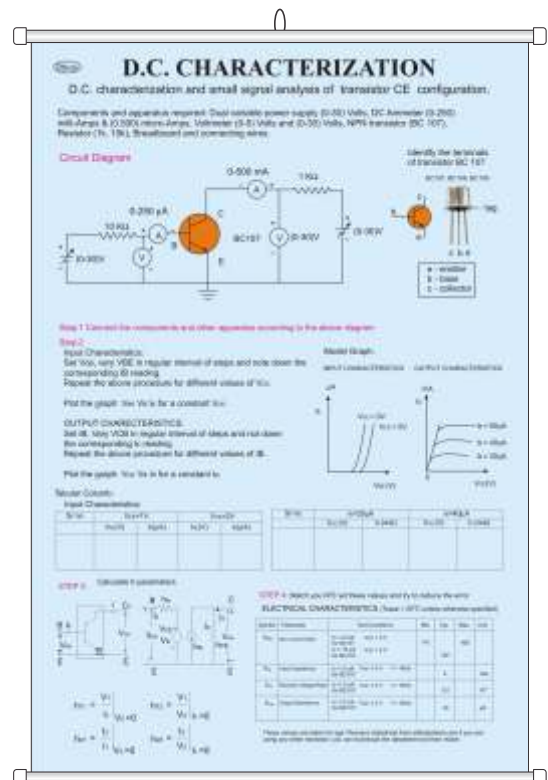

Size 20"x 30" Laminated and attached with durable strips

OR Laminated and Framed on Board



CH 2209

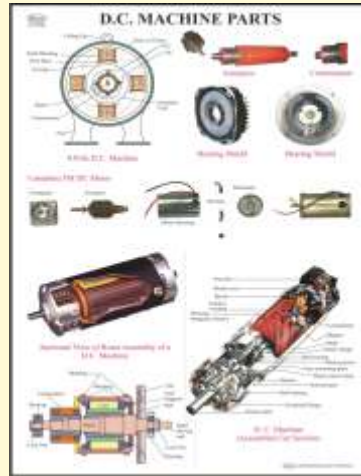

CH 2235



CH 2247

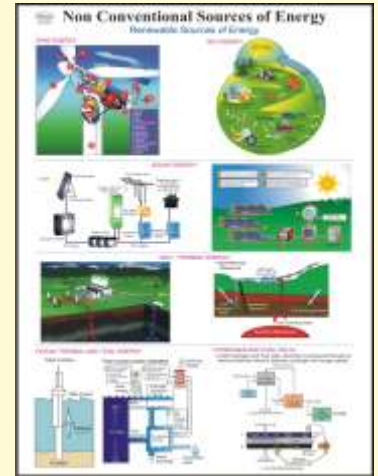

CH 2274

BASIC ELECTRICAL WORKSHOP

- CH 2200 Safety Precautions in Electric Laboratory
- CH 2201 Treatment Against Electric Shock
- CH 2202 Electric Bell
- CH 2203 Soldering Iron, Immersion Heater & Geyser
- CH 2204 Electrical Accessories - I
- CH 2205 Electrical Accessories - II
- CH 2206 Procedure of Making & Joint
- CH 2207 Types of Fuses
- CH 2208 Basic Electrical Symbols
- CH 2209 Light Bulb
- CH 2210 Mercury Vapour Lamps
- CH 2211 Fluorescent Tubes
- CH 2212 Sodium Vapour Lamps
- CH 2213 Wireman's Toos - I
- CH 2214 Wireman's Toos - II.
- CH 2215 Picture Tube
- CH 2216 Watt Hour Meter
- CH 2217 Cutaway of a Single Phase
- CH 2218 Electrical Estimation and Costing
- CH 2219 Stabilizers

E.M.I (ELECTRO MAGNETIC INDUCTION)

- CH 2225 Permanent Magnet Moving Coil Instrument (PMMC)
- CH 2226 Types of Moving Iron Instruments.
- CH 2227 A.C. Bridges - I (Measurement of Self Induction)
- CH 2228 A.C. Bridges - II (Measurement of Capacitances)

POWER SUPPORTING SYSTEMS

- CH 2271 Thyristor Family
- CH 2272 Chopper Circuits
- CH 2273 Inverter Circuit
- CH 2274 Non Conventional Sources of Energy

DC MACHINE.

- CH 2235 Parts of D.C. Machine
- CH 2236 Types of D.C. Generators
- CH 2237 Special Types of D.C. Machine
- CH 2238 D.C. Motor
- CH 2239 D.C. Generator
- CH 2240 Three Phase Rectifiers
- CH 2241 Cyclo Converters
- CH 2242 D. C. MOTOR STARTER

TRANSFORMERS

- CH 2245 Transformer
- CH 2246 Types of Winding In Transformer
- CH 2250 Three Phase and Scott Connected Transformer.

AC MOTOR

- CH 2247 Parts of Synchronous Machine
- CH 2248 A.C. Generator
- CH 2249 A.C. Motor
- CH 2252 Single Phase Induction Machine
- CH 2253 Three Phase Induction Machine

POWER GENERATION

- CH 2256 Coal Fired Power Station
- CH 2257 Hydro Power Station
- CH 2258 Nuclear Power Station
- CH 2259 Diesel Power Station
- CH 2260 Over Fired Line Insulation

POWER DISTRIBUTION

- CH 2251 Electrical Traction System
- CH 2265 Types of Electric Poles.
- CH 2266 Types of Cable
- CH 2267 Earthing
- CH 2268 Methods of Supporting a Pole

Ask for Big Size 30x40" Laminated Dbios Charts

Dbios ELECTRONIC CHARTS

Size 20"x 30" Laminated and attached with durable strips

OR Laminated and Framed on Board

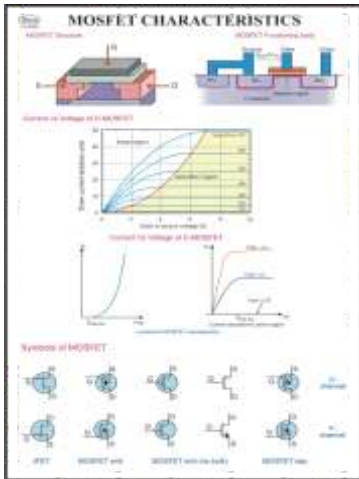

CH 2302



CH 2333

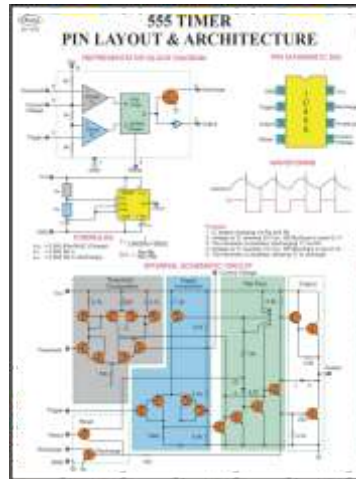

CH 1530

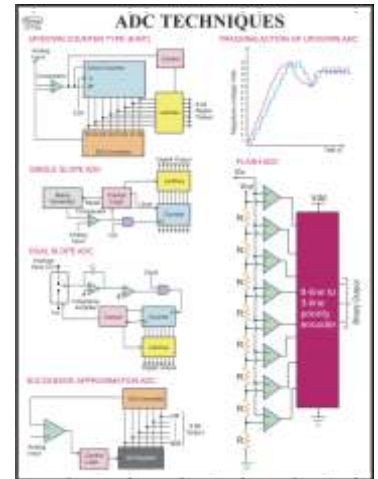

CH 1539

ANALOG DEVICES & CIRCUITS

- CH 2300 FET Characteristics
- CH 2301 UJT Characteristics
- CH 2303 Transistor Configurations and its Characteristics
- CH 2304 Class-A Amplifiers (Direct and Transformer Coupled)
- CH 2305 Push/Pull Amplifiers
- CH 2306 Transistor Hybrid Model and Hparameter
- CH 857 Semi-Conductors: Fundamentals
- CH 858 Semi-Conductors: Prop. & Characteristics
- CH 860 Oscillator
- CH 862 Transistor Characteristics
- CH 863 Triode Characteristics
- CH 864 Rectifiers
- CH 865 Symbols - I
- CH 866 Symbols - II

ELECTRONICS DEVICES AND CIRCUITS

- CH1523 Diodes-I: Zener, Varactor, Schottky & Tunnel
- CH1524 Diodes-II: Led, Photo, Pin, Laser
- CH1529 Cathode Ray Oscilloscope (CRO)
- CH 1530 555 Pin Diagram & Architecture
- CH 1531 555 Multi Vibrators
- CH 1532 Display Devices
- CH 2302 MOSFET Characteristics
- CH 2302a Working of MOSFET

DIGITAL CIRCUIT AND LOGIC DESIGN

- CH 861 Logic Gates
- CH 2310 Number Systems
- CH 2311 Codes
- CH 2312 Basic Theorems of Boolean Algebra
- CH 2313 Adders/ Subtractors
- CH 1534a Mux / Demux
- CH 1534b Encoders / Decoders
- CH 1535 Flip-Flops: SR,T,D.
- CH 1536 Flip-Flops: JK, Master-Slave JK
- CH 1537 Shift Register Types

- CH 1538 Universal Shift Registers
- CH 1539 ADC Techniques
- CH 1540 DAC Techniques
- CH 2314 Asynchronous Counters and Timing Diagram
- CH 2315 Synchronous Counter and Timing Diagram
- CH 2316 Internal Diagram of Memory (RAM/ROM)
- CH 2317 Programmable Logic Arrays (PLA)
- CH 2318 Programmable Array Logic (PAL)
- CH 2319 Field Programmable Gate Array (FPGA)
- CH 2320 Pseudo Random Sequence Generator
- CH 2321 Arithmetic Logic Unit

NETWORK ANALYSIS AND SYNTHESIS

- CH 2325 Network Theorems
- CH 2326 Representation of Basic Circuits in Terms of Frequency Domain
- CH 2327 Filters
- CH 2328 Butterworth and Chebyshev Filters
- CH 2329 Z-Transform of Causal and Non Causal Signals

LINEAR CONTROL SYSTEMS

- CH 2331 Error Detectors in Control Systems
- CH 2332 Compensation of the Linear Control Systems
- CH 2333 Components of Control Systems-1
- CH 2334 Components of Control Systems-2
- CH 2335 Modeling of Control Systems
- CH 2336 Process Control Timer
- CH 2337 Gauss-Seidal Method Flow Chart
- CH 2338 Voltage Waveforms For 180° Mode 3-Phase VSI
- CH 2339 Transformer Zero Sequence Equivalent Circuit
- CH 2340 Voltage and Current Wave Forms for A 3-Phase Semi-converter For Different Firing Angle.
- CH 2341 Voltage Waveforms And Conduction of Thyristors For A3-Phase Full Converter
- CH 2342 Components of a Power System
- CH 2343 Characteristics and Symbols of Some Power Devices
- CH 2344 Voltage and Current Waveforms for a Circulating Current Dual Converter

Ask for Big Size 30x40" Laminated Dbios Charts

Size 20"x 30" Laminated and attached with durable strips

OR Laminated and Framed on Board

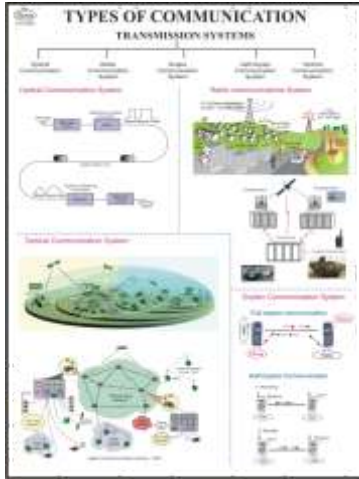

CH 2349

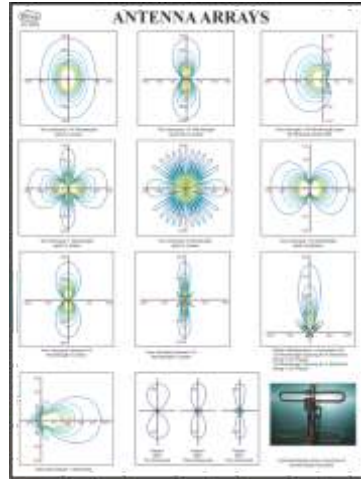

CH 2362



CH 1500

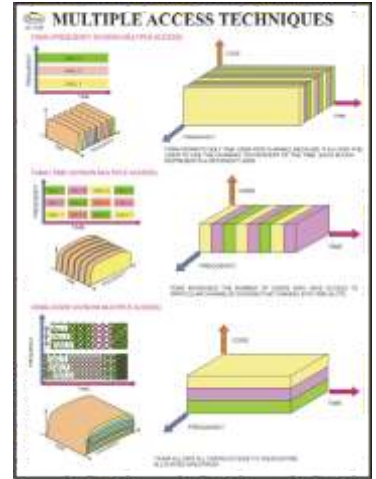

CH 1549

ANALOG COMMUNICATION SYSTEMS

- CH 2348 Types of Analog Modulation
- CH 2349 Types of Communication Transmission Systems
- CH 2350 AM Transmission (Square Law/ Ring/ Balanced)
- CH 2351 AM Receivers
- CH 2352 AM Mixers
- CH 2353 AM Detectors
- CH 2354 FM Transmitters
- CH 1505 FM Receivers
- CH 2355 FM Stereo and 2-Way FM Radio (Transmission & Reception)
- CH 1500 Wireless Communication Systems
- CH 1501 Single Side Band Modulation
- CH 2356 Single Side Band Reception
- CH 2357 Pulse Amplitude Modulation (PAM)
- CH 2358 Pulse Time/Pulse Width/ Pulse Position Modulation (PTM/PWM/PPM)
- CH 1502 Amplitude Modulation
- CH 1503 Frequency Modulation
- CH 1504 Radio Receivers
- CH 1533 PLL (Phase Locked Loop)

ELECTROMAGNETIC & ANTENNAS

- CH 2362 Antenna Arrays
- CH 2363 Aperture Antennas

PULSE WAVE SHAPING AND SWITCHING

- CH 2370 Monostable Multivibrator Using Transistor
- CH 2371 Astable Multivibrator Using Transistor
- CH 2372 Linear Phase Shaping Circuits and Response
- CH 2373 Clipping and Clamping
- CH 2374 Diode/ Transistor/ Operational Amplifier Comparators

DIGITAL COMMUNICATION SYSTEM

- CH 2378 Pulse Code Modulation (PCM)
- CH 2379 A-law & μ -law Companding
- CH 2380 Delta Modulation and Adaptive Delta Modulation
- CH 2381 Digital Carrier Line Encoding Techniques
- CH 2382 FSK Detectors
- CH 2383 Minimum Shift Keying (MSK) & Gaussian Minimum Shift Keying (GMSK)
- CH 1546A Digital Modulation-I (PSK Method)
- CH 1546B Digital Modulation-II (Other Methods)
- CH 1547 Digital Demodulation
- CH 1548 Sampling & Encoding Techniques
- CH 1549 Multiple Access Techniques (FDMA/CDMA/TDMA)

LINEAR INTEGRATED CIRCUIT

- CH 2385 Differential Amplifiers
- CH 2386 Operational Amplifier (Op-Amp)
- CH 1519 Feedback Amplifiers
- CH 1520 Multistage Amplifiers
- CH 2387 Compensating Networks and Compensated Op-Amp
- CH 2388 Applications Op-Amp-1: Mathematical operations
- CH 2389 Applications Op-Amp-2: Amplifier, Oscillator & Comparator
- CH 2390 Applications Op-Amp-3: Synthetic elements & Compensation
- CH 2391 Applications Op-Amp-4: Filters
- CH 1521 Operational Amplifier: Features
- CH 1522 Operational Amplifier: Open & Close Loop Configurations
- CH 1595 IC 741: Pin & Block Diagram

Ask for Big Size 30x40" Laminated Dbios Charts

Also Ask for Other Engg. Charts

Dbios ELECTRONIC CHARTS

Size 20"x 30" Laminated and attached with durable strips

OR Laminated and Framed on Board

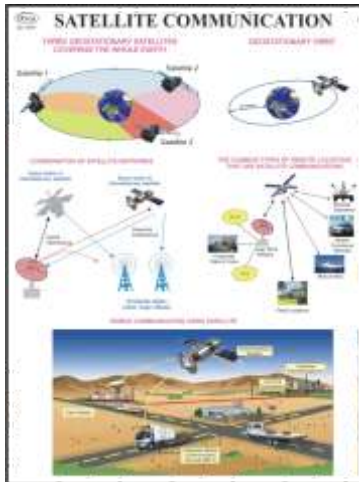

CH 1507

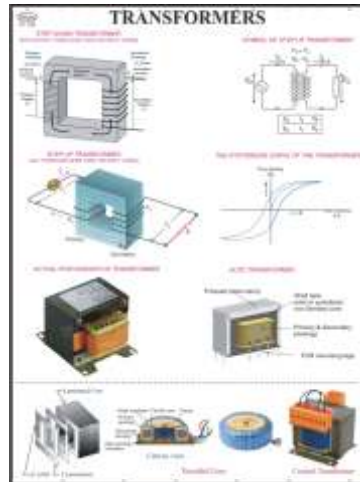

CH 1525

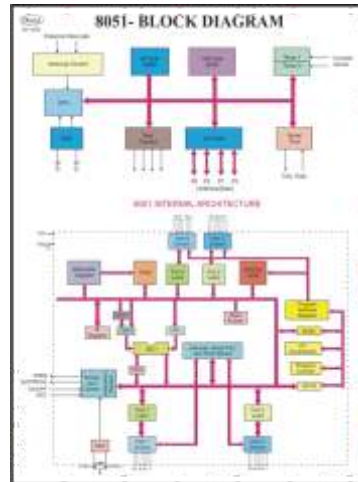

CH 1542



CH 1558

MICRO PROCESSORS & MICRO CONTROLLERS

- CH 1579 Micro-Controller Based System Design
- CH 1541 8051 Architecture & Pin Layout
- CH 1542 8051 Block Diagram
- CH 1543 8051 Instruction Set
- CH 1544 8051 SFR: Special Function Registers
- CH 1509 8086 Pin-layout & Architecture
- CH 1545A 8086 Instruction Set
- CH 1545B 8086 Instruction Set
- CH 1510 8085 Block Diagram
- CH 1511 8085 Pin Layout & Signal Representation
- CH 1512 8085 Set Instruction
- CH 1550 8085 Interrupts
- CH 1513 8255a The Programmable Peripheral Interface
- CH 1514 8155 Static Ram with I/O Ports and Timer
- CH 1515 8279: The Programmable Keyboard / Display Interface
- CH 1516A 8259 A: The Programable Interrupt Controller
- CH 1516B 8254 : The Programmable Interval Timer

MICROWAVE & RADAR ENGINEERING

- CH 2396 Microwave Components
- CH 2397 Microwave Tubes
- CH 2398 Microwave Solid State Devices
- CH 2399 Applications of Microwave
- CH 1580 Block Diagram and Applications of Radar
- CH 1581 Applications of Radar
- CH 1582 Types of Radar
- CH 1583 Scanning Techniques of Radar
- CH 1584 Angle Tracking System in Radar
- CH 1585 Radiation Pattern of Horn Antenna
- CH 1586 Measurement of Input Power and Isolated Power Setup

OPTICAL COMMUNICATION

- CH 1589 Types of Optical Fiber
- CH 1590 Numerical Aperture in Optical Fiber
- CH 1506 Fiber Optic Communication
- CH 1591 Losses in Optical Fiber
- CH 1592 Optical Transmitters
- CH 1593 Optical Receivers
- CH 1507 Satellite Communication
- CH 1508 Electromagnetic Frequency Spectrum

ELECTRONIC INSTRUMENTATIONS

- CH 1551 LVDT (Linear Variable Differential Transformer)
- CH 1552 PSPD (Pressure Sensitive Primary Devices)
- CH 1553 Control Valves
- CH 1554 Actuators
- CH 1555 Methods Of Measuring Liquid Level
- CH 1556 Strain Gauges
- CH 1557 Feed Forward & Ratio Control
- CH 1558 Types of Voltage Meters
- CH 1559 Resistance Measurement Using Bridge

INDUSTRIAL ELECTRONICS

- CH 1517 Diac & Triac
- CH 1518 UJT & SCR
- CH 1525 Transformer
- CH 1526 Dynamos
- CH 1527 Meter Principles-I (Analog Multimeter)
- CH 1528 Meter Principles-II (Multi Meter)
- CH 859 Krichoff's Law-Bridges

SIGNAL & SYSTEMS

- CH 1575 Transducers and Electrodes
- CH 1576 Classification of Signals

Ask for Big Size 30x40" Laminated Dbios Charts

VLSI & DSP (Very Large Scale Integration And Digital Signal Processing)

CH 1561	FABRICATION STEPS OF CMOS	CH 1568	Elementary Discrete Time Signals
CH 1562	STICK AND LAYOUT DIAGRAM OF LOGIC	CH 1569	Classification of Discrete Time Signals
CH 1563	High Level Design Flow: VHDL	CH 1570	Transformations of Discrete Time Signals
CH 1564	TMS320C6713 ARCHITECTURE	CH 1571	Properties of Convolution and Interconnection of LTI Systems:
CH 1565	RADIX 2 FFT ALGORITHM	CH 1572	Structures for the realization of LTI Systems
CH 1566	DIGITAL IIR FILTER STRUCTURES	CH 1573	Characteristics Families of signals and Their ROC's
CH 1567	DIGITAL FIR FILTER STRUCTURES		

Dbios NETWORKING charts

Size 20"x 30" Laminated and attached with durable strips
OR Laminated and Framed on Board

CH 2103	Storage Devices	CH 2110	Modes & Forms Of Data Transmission
CH 2104	Memories	CH 2111	Transmission Media
CH 2105	OSI Model	CH 2112	Types Of Computer Networks
CH 2106	Networking Devices	CH 2113	Communication Switching Techniques
CH 2107	Network Topologies	CH 2115	Microsoft Word
CH 2108	Input Devices	CH 2116	Microsoft Excel
CH 2109	Output Devices	CH 2117	Microsoft Power Point
		CH 2141	IP - Address

**O.H.P. Transparencies Version

* DVD Version

Print Out (Transparency) + CD Rom Version

- Unit-1 Introduction
- Unit-2 Number System
- Unit-3 Logic Gates
- Unit-4 Boolean Algebra
- Unit-5 Logic Families
- Unit-6 Combinational Circuits
- Unit-7 Arithmetic Circuits
- Unit-8 Encoders / Decoders / Display

- Unit-9 Multiplexers and Demultiplexers
- Unit-10 Latches and Flip-Flops
- Unit-11 Counters
- Unit-12 Registers
- Unit-13 Design of Sequential Circuits
- Unit-14 Memories
- Unit-15 Applications of ADC And DAC

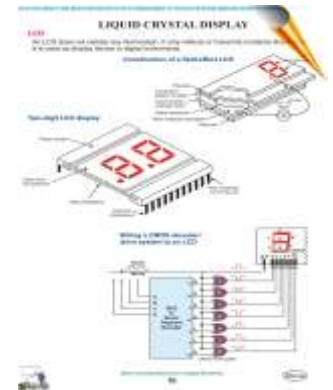

In our Continuous pursuit to unrivaled quality Dbios, now join Hands and Heads with SIBA to cater your Laboratory/Workshop needs under one roof.

- BASIC ELECTRONICS LAB
- ANALOG ELECTRONICS LAB
- Op-Amp LAB
- DIGITAL ELECTRONICS TRAINING LAB
- PROCESS CONTROL EQUIPMENTS LAB
- INSTRUMENTATION TRAINERS LAB
- POWER & INDUSTRIAL TRAINERS LAB
- COMMUNICATION TRAINERS LAB
- MEASUREMENT BRIDGES LAB



TRANSISTOR (BJT) CHARACTERISTICS



SYNCHRO TRANSMITTER - RECEIVER

Dbios ELECTRONIC & ELECTRICAL PIONEERS

Size 20"x 26" Laminated and Framed on NU-Wood Board

OR Size 12"x 18" Laminated and Framed on NU-Wood Board

- | | | | |
|-------|-------------------------|--------|----------------------|
| DE 01 | Guglielmo Marconi | DE 22 | Samuel F. B. Morse |
| DE 02 | Christiaan Huygens | DE 23 | John Logie Baird |
| DE 03 | John Ambrose Fleming | DE 24 | Edwin H. Armstrong |
| DE 04 | Alexander Graham Bell | DE 25 | John Bardeen |
| DE 05 | P.S. Laplace | DE 26 | Bob Wildar |
| DE 06 | Clarence Zener | DE 27 | Lord Kelvin |
| DE 07 | Julius Edgar Lilienfeld | DE 28 | Cloude Shannon |
| DE 08 | William Shoekley | DE 29 | Edward Hawry Norton |
| DE 09 | Alexander Volta | DE 30 | L.C. Thevenin |
| DE 10 | James Clark Maxwell | SCP 64 | William Gates |
| DE 11 | Max Plank | DCP 41 | R. Noyce & G. Moore |
| DE 12 | Johannes Kepler | DCP 44 | Steve Jobs |
| DE 13 | Max Born | DCP 45 | Steve Wozniak |
| DE 14 | Jack Kilby | SP 14 | Issac Newton |
| DE 15 | Sherman Fairchild | SP 15 | C. V. Raman |
| DE 16 | Andre-Marie Ampere | SP 18 | Neils Bohr |
| DE 17 | Georg Simon Ohm | SP 23 | Albert Einstein |
| DE 18 | Gustav Robert Kirchhoff | SC 27 | Gilbert Newton Lewis |
| DE 19 | Joseph Henry | SC 30 | Michael Faraday |
| DE 20 | Heinrich Rudolf Hertz | SP 31 | Ernest Rutherford |
| DE 21 | Nikola Tesla | SP 46 | Thomas Alva Edison |



20"x26"



12"x18"

**Ask for Mechanical, Workshop,
Civil, Computer/IT Charts**