

BUSHED ROLLER CHAINS

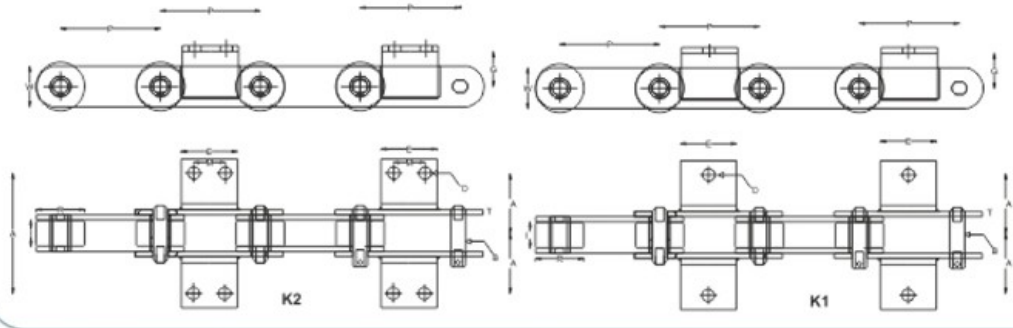

Slat Conveyor & Elevator Chains



CHAIN NO.	PITCH P	BREAKING LOAD KGS	PIN		ROLLER		LINK		ATTACHMENT				
			B ϕ	L APP.	R ϕ	I	W	T	A	D ϕ	E	G	M
TR 040	40.00	7000	10.05	46.0	30.00	18.0	25.0	4.5	28.0	7.0	P-20	18.5	--
TR 041	41.30	5000	8.25	38.0	15.55	21.0	25.0	3.1	35.0	8.3	P-22	16.0	--
TR 050	50.00	5000	9.50	40.0	30.00	15.0	25.0	3.0	30.0	9.5	25.0	18.0	--
TR 021	50.80	5000	10.05	42.0	31.75	15.0	25.0	4.0	40.0	10.5	30.0	18.0	--
TR 058	58.34	8000	10.05	48.0	19.05	22.4	28.0	6.0	36.5	11.5	P-27	17.0	--
TR 063	63.00	3500	8.00	40.0	30.00	16.0	20.0	3.0	40.0	11.2	45.0	13.0	--
TR 025	63.50	7500	14.50	70.0	25.40	23.0	30.0	5.0	40.0	11.2	45.0	18.0	--
TR 066	66.26	8000	11.05	64.0	22.20	28.5	30.0	5.0	50.0	8.5	55.0	26.0	--
TR 031	76.20	11000	14.50	66.0	50.00	35.0	40.0	5.0	35.0	6.5	35.0	21.0	--
TR 032	76.20	12000	15.70	70.0	50.00	30.0	35.0	6.0	35.0	10.0	35.0	17.0	--
TR 033	76.20	8000	10.05	55.0	38.00	20.0	30.0	5.0	38.0	11.2	38.0	24.0	--
TR 080	80.00	18000	15.70	84.0	60.00	42.0	50.0	7.0	50.0	17.5	50.0	35.0	--
TR 0100	100.00	8000	11.05	66.0	55.00	25.0	40.0	5.0	50.0	11.2	62.0	28.0	36.0
TR 042	101.60	8000	10.05	65.0	47.62	30.0	30.0	5.0	65.0	12.7	72.0	28.5	38.0
TR 044	101.60	10000	15.70	57.0	50.00	20.0	40.0	5.0	35.0	10.5	63.0	20.0	--
TR 045	101.60	12000	15.75	72.0	50.80	35.0	40.0	5.0	75.0	11.2	55.0	30.0	32.0
TR 046	101.60	15000	14.50	55.0	38.00	20.0	45.0	6.0	35.0	10.5	65.0	21.0	--
TR 0120	120.00	8000	10.05	55.0	38.00	20.0	30.0	5.0	40.0	11.2	62.0	26.0	36.0
TR 0125	125.00	8000	10.05	55.0	38.00	20.0	30.0	5.0	40.0	11.2	62.0	26.0	36.0
TR 0126	125.00	25000	19.70	96.0	80.00	45.0	65.0	8.0	65.0	17.5	60.0	40.0	--
TR 0127	125.00	12000	14.50	75.0	30.00	30.0	40.0	5.0	50.0	9.5	60.0	40.0	--
TR 150	150.00	20000	19.70	102.0	60.00	50.0	50.0	7.8	70.0	11.2	30.0	45.0	--
TR 061	152.40	8000	12.70	60.0	40.00	26.0	30.0	5.0	45.0	11.2	100.0	15.0	60.0
TR 062	152.40	11000	10.05	52.0	38.00	20.0	30.0	6.0	62.5	12.0	80.0	40.0	45.0
TR 064	152.40	15000	15.75	75.0	47.62	32.0	45.0	6.0	45.0	14.5	56.0	25.0	--
TR 065	152.40	20000	19.70	80.0	68.00	32.0	50.0	7.8	55.0	14.0	90.0	40.0	50.0
TR 067	152.40	20000	19.70	95.0	50.00	46.0	50.0	7.8	70.5	14.0	60.0	32.0	--
TR 068	152.40	25000	22.00	95.0	76.20	35.0	50.0	10.0	65.0	17.5	90.0	45.0	65.0
TR 069	152.40	40000	25.00	90.0	80.00	40.0	70.0	12.0	50.0	17.5	120.0	55.0	80.0
TR 0160	160.00	50000	23.00	135.0	90.00	55.0	75.0	10.0	75.0	14.5	120.0	70.0	85.0
TR 0200	200.00	27000	19.75	111.0	80.00	52.0	50.0	10.0	70.0	17.5	130.0	55.0	90.0
TR 0203	203.20	25000	22.00	110.0	88.00	44.0	70.0	10.0	65.0	17.5	125.0	56.0	83.0
TR 091	228.60	18000	19.00	100.0	88.00	52.0	50.0	7.0	73.0	13.5	140.0	63.0	90.0
TR 0251	250.00	20000	20.00	90.0	67.00	30.0	50.0	8.0	75.0	14.5	110.0	50.0	80.0
TR 0252	250.00	40000	29.95	122.0	90.00	54.0	70.0	10.0	50.0	21.5	180.0	120.0	130.0
TR 0253	250.00	50000	26.00	125.0	75.00	40.0	65.0	14.0	100.0	21.5	160.0	45.0	85.0
TR 0254	250.00	70000	34.00	143.0	85.00	53.0	70.0	16.0	80.0	21.0	175.0	50.0	90.0
TR 0255	250.00	45000	25.00	106.0	100.00	48.0	70.0	10.0	85.0	21.0	150.0	120.0	120.0
TR 011	254.00	18000	19.75	100.0	70.00	45.0	50.0	8.0	65.0	13.5	120.0	30.0	70.0
TR 012	254.00	10000	15.70	81.0	58.00	45.0	40.0	5.0	75.0	14.0	120.0	42.0	35.0
TR 013	304.80	30000	22.00	120.0	76.00	57.0	65.0	10.0	73.0	13.5	203.0	63.5	152.0
TR 0400	400.00	40000	29.00	120.0	90.00	50.0	70.0	12.0	8.0	17.5	260.0	35.0	160.0
TR 0600	600.00	25000	32.00	100.0	96.00	39.5	70.0	10.0	--	--	--	--	--

ALL DIMENSIONS ARE IN MM. ATTACHMENT : WELDED, RIVETTED, INTEGRAL TYPE WITH A1, A2, K1, K2, M1, G20, F TYPE ETC.
 ROLLER : PLAIN / FLANGED TYPE PIN : CONSTRUCTION RIVETTED / COTTERED TYPES



An ISO 9001-2008 Certified Company