

# H-SQP Series Low noise fixed displacement vane pumps

## DOUBLE PUMPS

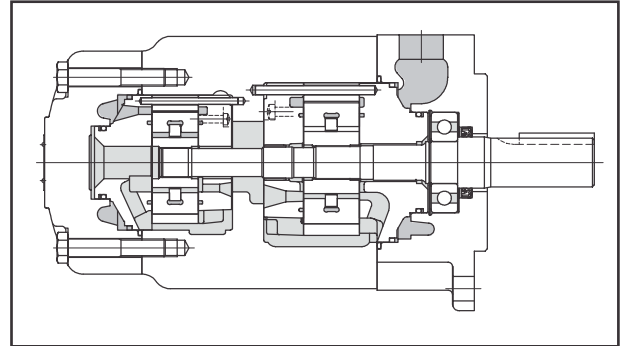
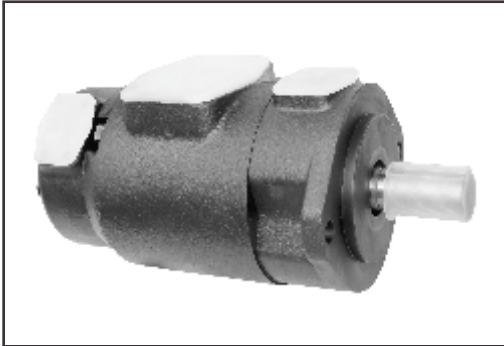

### ORDERING CODE

**(F3) - H-SQP32 - 35 - 17 - 86-CD- (LH) - 18**

- 1
- 2
- 3
- 4
- 5
- 6
- 7
- 8
- 9

- 1** Fluid  
Omit for mineral oil  
F3: phosphate ester  
F11: water glycol
- 2** Low noise fixed displ. double vane pump  
H-SQP21 Series  
H-SQP31,32 Series  
H-SQP41,42,43 Series
- 3** Shaft end pump displacement

Series	Displacement
H-SQP2*	10,12,14,15,17,19,21
H-SQP3*	21,25,30,32,35,38,45
H-SQP4*	42,45,50,57,60,66,75

- 4** Cover end pump displacement

Series	Displacement
H-SQP*1	2,3,4,5,6,7,8,9,11,12,14
H-SQP*2	10,12,14,15,17,19,21
H-SQP*3	21,25,30,32,35,38,45

- 5** Shaft  
86: parallel sq. key  
1: parallel sq. key
- 6** Shaft end pump (viewed from cover end)  
A: opposite inlet  
B: 90° CCW from inlet  
C: inline with inlet  
D: 90° CW from inlet
- 7** Cover end pump (viewed from cover end)  
A: 135° CCW from inlet  
B: 45° CCW from inlet  
C: 45° CW from inlet  
D: 135° CW from inlet
- 8** Rotation (viewed from shaft end)  
Omit for CW  
LH: CCW
- 9** Design no

• Outlet port position

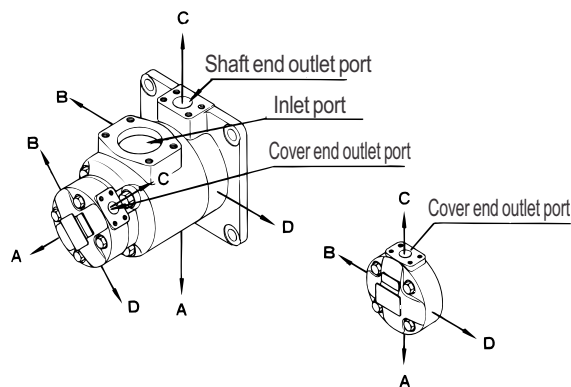

H-SQP43 Series

# H-SQP32 (Flange Mount)

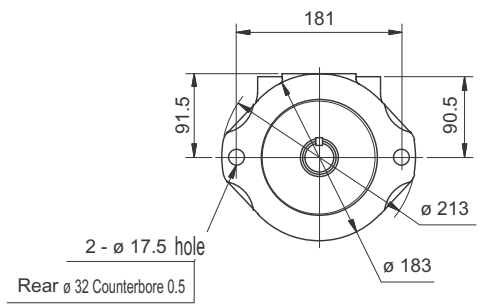
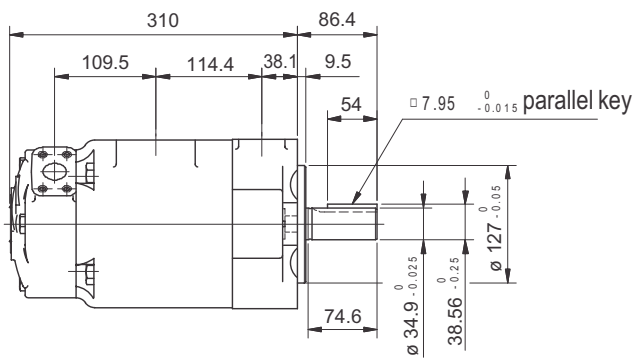
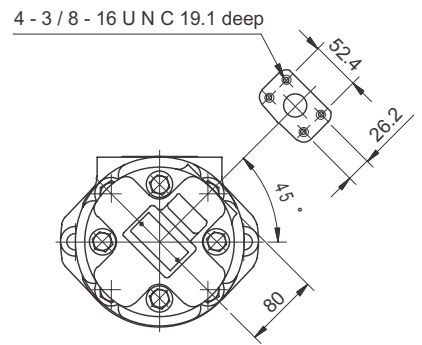
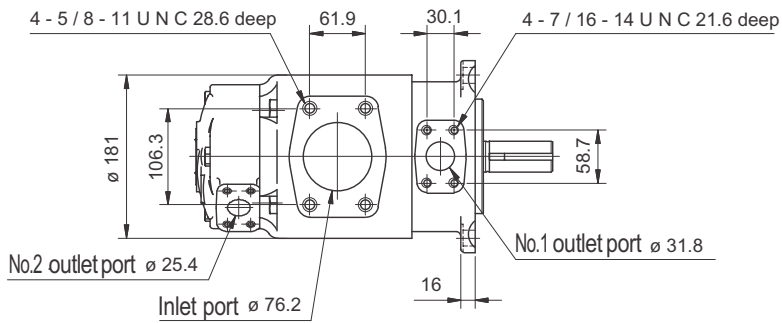

Model Numbers	Approx. Weight (kg)
H-SQP32	48.1

## Specifications

Model	Shaft End Pump			Cover End Pump			Max. Speed min	Minimum Speed min <sup>-1</sup>
	Displacement	Nominal Displacement cm <sup>3</sup> /rev	Max. Working Press. MPa	Displacement	Delivery at 1000 min <sup>-1</sup> 0.7Mpa L/min	Max. Working Press. MPa		
H-SQP32	21	66.7	17.5 *(14)	10	32.5	17.5 *(14)	1800 ▲ (1200) *(1200)	600
	25	79.2		12	38.3			
	30	95.0		14	43.3			
	32	100.0		15	46.7			
	35	109.0		17	52.5			
	38	118.0		19	59.2			
	45	140.0	14.0 *(12)	21	65.0			

\*F3-H-SQP max. working pressure and sped with phosphate ester fluid  
 ▲ F11-H-SQP max. speed with water-glycol fluid