

H-SQP Series Low noise fixed displacement vane pumps

SINGLE PUMPS

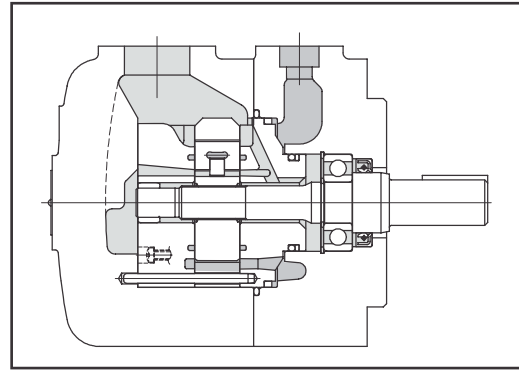
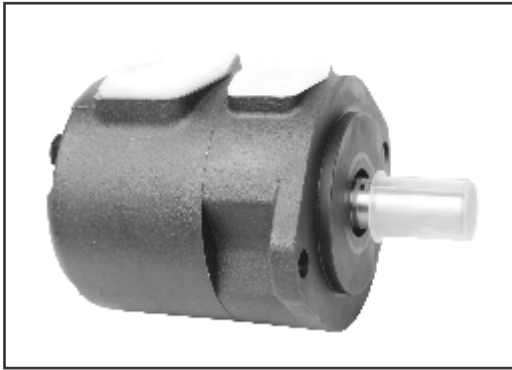

ORDERING CODE

(F3) - H-SQP3 - 35 - 86- C -(LH) - 18

1 2 3 4 5 6 7

- | <p>1 Fluid
 Omit for mineral oil
 F3: phosphate ester
 F11 : water glycol</p> <p>2 Low noise fixed displ. vane pump
 H-SQP1 Series
 H-SQP2 Series
 H-SQP3 Series
 H-SQP4 Series</p> <p>3 Pump displacement code</p> <table border="1" style="width: 100%; border-collapse: collapse;"> <thead> <tr> <th style="text-align: left;">Series</th> <th style="text-align: left;">Displacement</th> </tr> </thead> <tbody> <tr> <td>H-SQP1</td> <td>2,3,4,5,6,7,8,9,11,12,14</td> </tr> <tr> <td>H-SQP2</td> <td>10,12,14,15,17,19,21</td> </tr> <tr> <td>H-SQP3</td> <td>21,25,30,32,35,38,45</td> </tr> <tr> <td>H-SQP4</td> <td>42,45,50,57,60,66,75</td> </tr> </tbody> </table> | Series | Displacement | H-SQP1 | 2,3,4,5,6,7,8,9,11,12,14 | H-SQP2 | 10,12,14,15,17,19,21 | H-SQP3 | 21,25,30,32,35,38,45 | H-SQP4 | 42,45,50,57,60,66,75 | <p>4 Shaft</p> <p style="margin-left: 20px;">1 parallel sq. key H-SQP1
 H-SQP2</p> <p style="margin-left: 20px;">86 parallel sq. key H-SQP3
 H-SQP4</p> <p>5 Outlet port position (viewed from cover end)
 A: opposite inlet
 B: 90' CCW from inlet
 C: inline with inlet
 D: 90' CW from inlet</p> <p>6 Rotation (viewed from shaft end)
 Omit for CW
 LH: CCW</p> <p>7 Design no.</p> |
|---|--------------------------|--------------|--------|--------------------------|--------|----------------------|--------|----------------------|--------|----------------------|---|
| Series | Displacement | | | | | | | | | | |
| H-SQP1 | 2,3,4,5,6,7,8,9,11,12,14 | | | | | | | | | | |
| H-SQP2 | 10,12,14,15,17,19,21 | | | | | | | | | | |
| H-SQP3 | 21,25,30,32,35,38,45 | | | | | | | | | | |
| H-SQP4 | 42,45,50,57,60,66,75 | | | | | | | | | | |

•Outlet port position

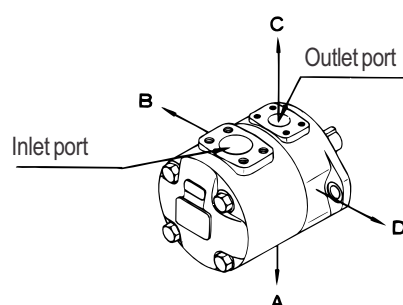

H-SQP4 (Flange Mount)

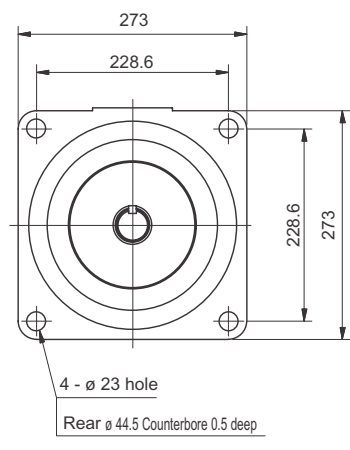
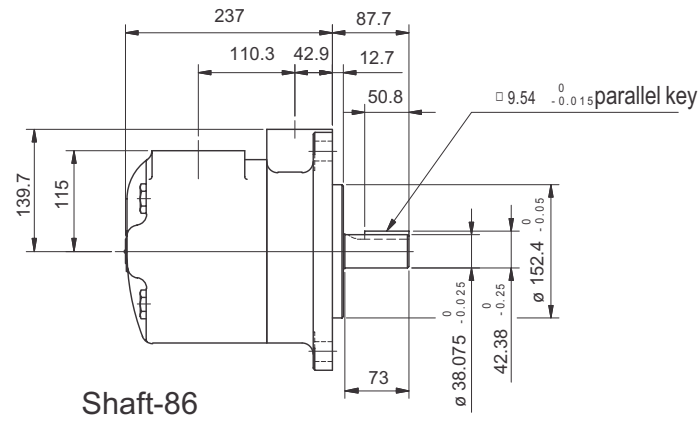
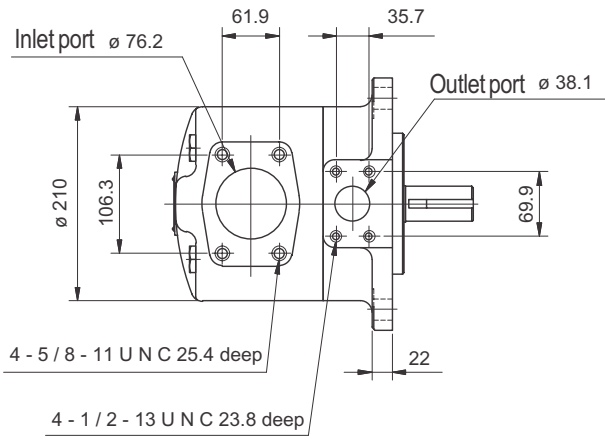

Model Numbers	Approx. Weight (kg)
H-SQP4	60.0

Specifications

Model	Displ. Code	Nominal Displacement cm^3/rev	Mineral Oil H-SQP		Phosphate Ester F11-H-SQP		Water-Glycol F3-H-SQP		Min. Speed min^{-1}
			Max. Pressure MPa	Max. Speed min^{-1}	Max. Pressure Mpa	Max. Speed min^{-1}	Max. Pressure MPa	Max. Speed min^{-1}	
H-SQP4	42	134.0	17.5	1800	17.5	1200	14	1200	600
	45	140.0							
	50	156.0							
	57	178.0	14.0						
	60	189.0							
	66	212.0							
	75	237.0							