

MOUNTING, OPERATING, TESTING & MAINTENANCE INSTRUCTIONS FOR ROTEX SPOOL VALVE MODEL GDAF 7210

ROTEX retains all rights to this publication.

All details within this manual and the catalogue are subject to change without manner.

ROTEX will not be responsible for any damage whatsoever arising from the use of the Solenoid Valve, due to misuse or incorrect installation or misinterpretation of the information contained herein.

SPECIFICATION OF STANDARD SOLENOID VALVE

TYPE	:	3 Port 2 Position,
OPERATION	:	Internal Pilot Operated Spool Type Air Operated Spring Return Valve
ORIFICE = NW	:	6.7 mm
OPERATING PRESSURE	:	0-16 bar
MANUAL OVERRIDE	:	Provided.
SEALS & SEAT	:	The valve is provided with VITON Seals & Seat material.

CONSTRUCTION

Body Internal	Aluminium (*)	Brass (B2)	SS316 (B5)	Aluminium (B1)
Core Tube	SS304			
Core Plug & Plunger	SS430, Electroless Nickel Plated			
Seals		Viton (S2)		
Springs	SS302			

IDENTIFICATION ON THE VALVE

a) VALVE LABEL

Label on the ROTEX Solenoid Valve shows the following details :

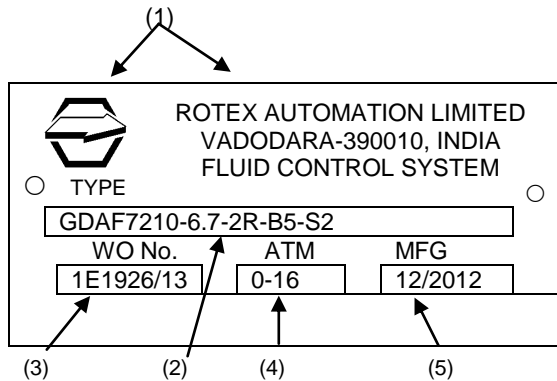

- (1) Logo + Manufacturer's Name & address
- (2) Valve Type / Code
 GDAF7210 = Valve Model
 Suffix = Nil
 6.7 mm = Orifice
 2R = 1/4" Port Connection (NPT)
 B5 = Body Material (SS 316)
 S2 = Seal Material (Viton)

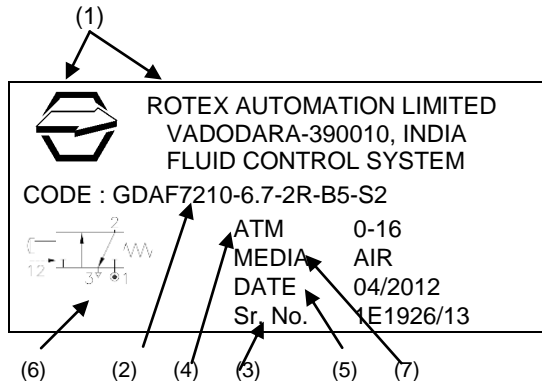

- (3) Manufacturer's Work Order reference / Sr. No. of the Valve
- (4) Operating Pressure
- (5) Manufacturing Month & Year
- (6) Valve Symbol
- (7) Media

b) PORT IDENTIFICATION

A solenoid Valve with NPT (F) threading is normally marked “N” near the port and with Metric threads are marked “M”. For ports with BSP threads, there is no marking.

⚠ NOTE : The product without label is out of warranty and risk.

CONNECTION

VALVE TYPE	Operation	Inlet	Outlet	Exhaust
GDAF7210	NC	1	2	3
	NO	3	2	1

A) OPERATING PRINCIPLE

The spool valve assembly consists of a sliding cylindrical spool , manufactured to very close tolerances with a very smooth surface low friction surface finish. These are manufactured to a very high standard and can operate without lubrication if required.

NC Operation

When Pilot Pressure applied which blocked under sealing at spool, Inlet port-1 is not connected to Outlet port-2.By releasing Pressure spool pushes to spring which connects Inlet port-1 to Outlet Port-2 and air exhausted through port-3.

NO Operation

When Pilot Pressure applied, hence Inlet port-3 is directly connected to Outlet port-2. So pressure continuously available at Outlet port-2 .By releasing pressure spool pushes to spring which disconnects Inlet port-3 to Outlet Port-2 and air exhausted through port-1.

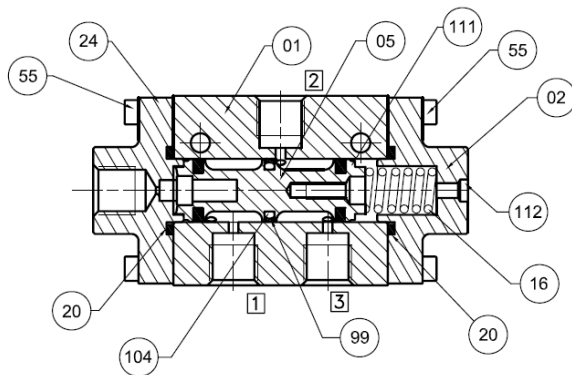

CONNECTION

- 1 INLET
- 2 OUTLET
- 3 EXHAUST

01	MUFFLER	11	112	S.BRONZE
01	BODY SEAL	10	111	VITON
03	SLEEVE 'O' RING	09	104	VITON
03	GLYDRING	08	99	PTFE
08	SHCS M4x16	07	55	-
01	DECKEL	06	24	AL/SS 316
02	BODY 'O' RING	05	20	VITON
01	SPRING	04	16	SS 302
01	SPOOL	03	05	SS 316
01	DECKEL FOR SPRING	02	02	AL/SS 316
01	BODY (GEHAUSE)	01	01	AL/SS 316
QTY.	DESCRIPTION	SR.No.	POS.No.	MATERIAL

(B) MOUNTING/INSTALLATION PROCEDURE:

1. ENSURE THAT:

- a) While storing, keep the valve in cool, dry, dust free area.
- b) On receipt of the valve, in case if the same is to be removed from the sealed plastic bag for inspection/testing, put them back with dust plugs on its ports and sealing the plastic bag as soon as the inspection/testing is over.
- c) The valve should be removed from its card board and/or plastic bag just before the installation.
- d) Flush lines before installing the valve.
- e) To avoid pressure drop and to achieve optimum parameters, Pipe / Tube / Fitting from the source of pressure to the valve and to the connected equipment should have ID which is \geq NW (Orifice) of the valve.



- f) To avoid pressure drop, if more than one valve is being operated simultaneously from a common header, then minimum ID of the header can be calculated as under.

$$ID\ Header = \sqrt{(NW^2 \times n)}$$
 n = Number of Valves operating at a time and which are connected to a common header,
 NW = Orifice of the Valve.



- g) Incorporate filter in the line to avoid hard particles entering into the valve.
 h) Do not try to drill any additional holes or machine, modify any of the valve components.
 i) Inlet pressure does not exceed rated pressure.
 j) Hemp-Filaments, 'Jute' or even Teflon-Ribbons are normally not required, as the port connections of ROTEX Valve is accurately machined.
 k) Do not cover first two thread pitches with Teflon tape or sealant. To avoid over lap of the Teflon ribbon or cuts generated while tightening, getting carried away into the valve.

2. The process fluid etc. does not fall on the valve body.

3. Install valve in such a way that the rain water / other process fluid dripping along the cable does not fall on the Valve and has no possibility to run along the cable and enter into the Terminal area.

4. It is not likely however; the user is advised to protect the valve against lightening as the same is not assessed.

5. Check internal components (wetted) parts for its compatibility with fluid passing through the valve.

TESTING OF THE VALVE AT THE TEST BENCH

- 1) Connect Air Pressure at inlet Port .
- 2) When pilot pressure is applied check leakage at Exhaust port-3(NC operation) & Exhaust port-1(NO operation) of the valve by applying soap solution.
- 3) Check leakage at joints of the valve by applying soap solution.

RECOMMENDED SPARES

- a) Seal Kit (O Ring) (Code – 98).
- b) Repair Kit (Code – 99)

SPARE ORDERING CODE

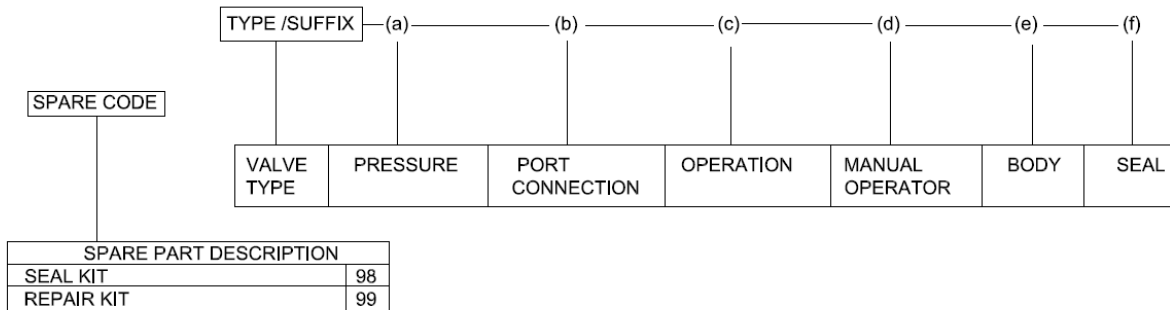



RECOMMENDED MAINTENANCE

- Replacement of Complete Set of O Ring

PREVENTIVE

Once in 5 years or 2 million operations.

MAINTENANCE – GENERAL INSTRUCTION :

-  It is recommended to replace complete set of O Ring even if one of the O Ring is damaged. This is to ensure trouble free operation of the valve and will avoid its premature failure.
- Using Grease other than Silicon base Molykote 33M will lead to premature failure of O Rings of the **ROTEX** Solenoid valve.
-  If necessary to clean the components, **do not use Kerosene, Diesel, Petrol to clean valve as this damages the O Rings and other rubber material. Instead use light Detergent Soap Solution.**
- Ensure that the components are free from dust, dirt, lint and metal burrs.
- Twisting of O Ring should be avoided. Ensure that the twist is removed before fitting matching part.
- While closing the matching part, the matching part should be pushed in a straight line. Turning motion should be avoided.
- Pinching of O Ring at the groove corner at the time of closing gland should be avoided.
- User is requested to use safe practice for maintenance.
- It is important to place the dismantled Valve Parts on a clean paper or cloth in same sequence in which you have dismantled them.
- Ensure to keep all the components of the valve separately to avoid their mixing up. The component appears to be same may have small differences which will cause malfunction if interchanged.
- In case of difficulty you should contact the Agent, Distributor or **ROTEX** directly.
- Using **ROTEX** genuine spares will **guarantee** you trouble free operation and will avoid premature failure.

(A) TO REPLACE SPOOL ASSEMBLY

- 1) Open four bolts of air deckel and pull out the same.
- 2) Open four bolts of deckel for handle and pull out the same.
- 3) Replace the necessary defective parts ensuring that Spool assly.
- 4) Fix the spool assly using correct tool.

(B) REPLACEMENT OF O RINGS

- 1) Remove all the "O" Rings.
- 2) Clean components.
- 3) Fix new O Rings applying light layer of Molykote 33M grease.
- 4) Ensure that the O Rings and other rubber parts are compatible to the media passing through the valve.
- 5) Reassemble the valve.
- 6) Check operation and leakage of the valve
- 7) Contact ROTEX in case of any difficulty.

STORING, CLEANING AND MOUNTING OF ELASTOMERS: SYNTHETIC RUBBER PRODUCTS

- Store Spool, O Ring Set in sealed polyethylene bag, kept in cool, dry, dust free area and avoid direct contact with all light sources emitting ultra violet rays, or contact with fumes, solvents, fuels, lubricants, chemicals, acids, disinfectants.
- Follow Maintenance General Instruction & specific procedures to replace O Ring set as listed above.

Contact:**ROTEX AUTOMATION LIMITED**

987/11, GIDC, MAKARPURA, VADODARA – 390010, INDIA

Tel.: +91 265 2638136, 2638746, 2638795 Fax: +91 265 2638130

E-mail: rotexbrd@rotexindia.comWebsite: www.rotexindia.com