

MOUNTING, OPERATING, TESTING & MAINTENANCE INSTRUCTIONS FOR ROTEX SPOOL VALVE MODEL GDAF 7211

ROTEX retains all rights to this publication.

All details within this manual and the catalogue are subject to change without manner.

ROTEX will not be responsible for any damage whatsoever arising from the use of the Solenoid Valve, due to misuse or incorrect installation or misinterpretation of the information contained herein.

SPECIFICATION OF STANDARD SOLENOID VALVE

TYPE	:	3 Port 2 Positions,
OPERATION	:	Spool Type Air Operated Air Return Valve.
ORIFICE = NW	:	6 mm
OPERATING PRESSURE	:	0-16 bar
SEALS & SEAT	:	The valve is provided with VITON Seals & Seat material.

CONSTRUCTION

Body	SS316	(*)	Aluminium	(B1)		
Internal	SS316		SS316			
Seals	NBR (SN)		Viton (S2)			
Springs	SS302					

IDENTIFICATION ON THE VALVE

a) VALVE LABEL

Label on the ROTEX Solenoid Valve shows the following details:

(1)

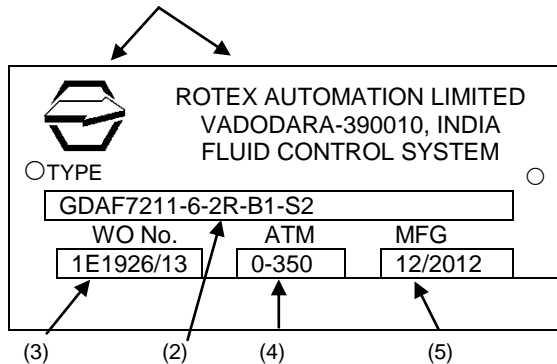

- (1) Logo + Manufacturer's Name & address
- (2) Valve Type / Code
 GDAF7211 = Valve Model
 Suffix = Nil
 6 mm = Orifice
 2R = 1/4" Port Connection (NPT)
 B1 = Body Material (Aluminum)
 S2 = Seal Material (Viton)

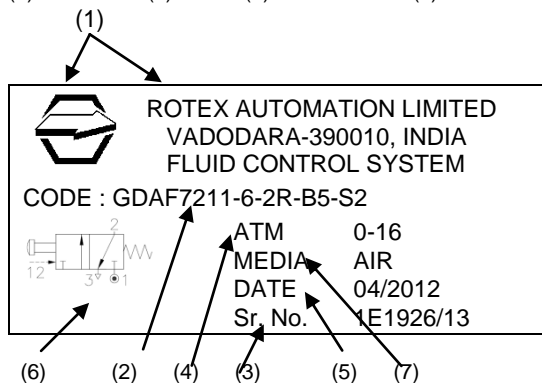

- (3) Manufacturer's Work Order reference / Sr. No. of the Valve
- (4) Operating Pressure
- (5) Manufacturing Month & Year
- (6) Valve Symbol
- (7) Media

b) **PORT IDENTIFICATION**

A solenoid Valve with NPT (F) threading is normally marked “N” near the port and with Metric threads are marked “M”. For ports with BSP threads, there is no marking.

⚠ NOTE: The product without label is out of warranty and risk.

CONNECTION

VALVE TYPE	Operation	Inlet	Outlet	Exhaust	PILOT IN	PILOT IN
GDAF7211	NC	1	2	3	12	14
	NO	3	2	1	12	14

A) **OPERATING PRINCIPLE**

The spool valve assembly consists of a sliding cylindrical spool, manufactured to very close tolerances with a very smooth surface low friction surface finish. These are manufactured to a very high standard and can operate without lubrication if required.

NC Operation

In NC condition, inlet port-1 is disconnected to outlet port-2. When the pilot air is entered from port-12 it pushes spool and sleeve towards right allowing inlet port-1 to get connected to outlet Port-2 and air is exhausted through port-3.

When Pilot air is removed, the spool will stay there. In order for the spool to go back to its original position Pilot air from Port-14 is turned on.

NO Operation

In NO condition, inlet Port-3 is connected to outlet Port-2. When the Pilot air is entered from Port-12 it pushes spool and sleeve towards right pushes the spring closing inlet Port-3 and outlet Port-2, and air is exhausted through Port-1.

In order for the spool to go back to its original position Pilot air from Port-14 is turned on.

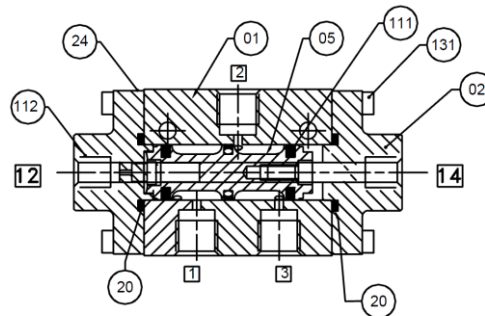

GDAF 7211

10	MUFFLER	1	112	S.BRONZE
9	BODY SEAL	1	111	VITON
8	SLEEVE O- RING	3	104	VITON
7	GLYDRING	3	99	PTFE
6	SHCS M4 X 16	8	131	SS 304
5	DECKEL	1	24	AL/ SS 316
4	BODY 'O' RING	2	20	VITON
3	SPOOL	1	05	SS 316
2	DECKEL	1	02	AL/ SS 316
1	BODY (GEHAUSE)	1	01	AL/ SS 316
SR. NO.	DESCRIPTION	QTY.	POS. NO.	MATERIAL

CONNECTION

- 1** INLET
- 2** OUTLET
- 3** EXHAUST
- 12** PILOT IN
- 14** PILOT IN

(B) MOUNTING/INSTALLATION PROCEDURE:

1. ENSURE THAT:

- a) While storing, keep the valve in cool, dry, dust free area.
- b) On receipt of the valve, in case if the same is to be removed from the sealed plastic bag for inspection/testing, put them back with dust plugs on its ports and sealing the plastic bag as soon as the inspection/testing is over.
- c) The valve should be removed from its card board and/or plastic bag just before the installation.
- d) Flush lines before installing the valve.
- e) To avoid pressure drop and to achieve optimum parameters, Pipe / Tube / Fitting from the source of pressure to the valve and to the connected equipment should have ID which is \geq NW (Orifice) of the valve.
- f) To avoid pressure drop, if more than one valve is being operated simultaneously from a common header, then minimum ID of the header can be calculated as under.

$$ID \text{ Header} = \sqrt{NW^2 \times n}$$
 n = Number of Valves operating at a time and which are connected to a common header,
 NW = Orifice of the Valve.
- g) Incorporate filter in the line to avoid hard particles entering into the valve.
- h) Do not try to drill any additional holes or machine, modify any of the valve components.
- i) Inlet pressure does not exceed rated pressure.
- j) Hemp-Filaments, 'Jute' or even Teflon-Ribbons are normally not required, as the port connections of ROTEX Valve is accurately machined.
- k) Do not cover first two thread pitches with Teflon tape or sealant. To avoid over lap of the Teflon ribbon or cuts generated while tightening, getting carried away into the valve.

2. The process fluid etc. does not fall on the valve body.

3. Install valve in such a way that the rain water / other process fluid dripping along the cable does not fall on the Valve and has no possibility to run along the cable and enter into the Terminal area.

4. It is not likely however; the user is advised to protect the valve against lightening as the same is not assessed.

5. Check internal components (wetted) parts for its compatibility with fluid passing through the valve.

TESTING OF THE VALVE AT THE TEST BENCH

- 1) Connect Air Pressure at inlet Port.
- 2) When valve is in normal condition check leakage at Exhaust port-3(NC operation) & Exhaust port-1(NO operation) of the valve by applying soap solution.
- 3) Check leakage at joints of the valve by applying soap solution.

RECOMMENDED SPARES

- a) Seal Kit (O Ring) (Code – 98).
- b) Repair Kit (Code – 99)

SPARE ORDERING CODE

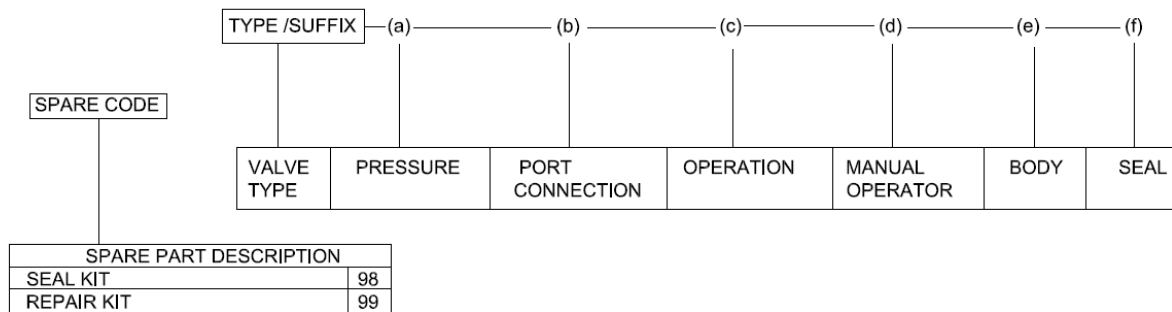



RECOMMENDED MAINTENANCE

- Replacement of Complete Set of O Ring

PREVENTIVE

Once in 5 years or 2 million operations.

MAINTENANCE – GENERAL INSTRUCTION :

-  It is recommended to replace complete set of O Ring even if one of the O Ring is damaged. This is to ensure trouble free operation of the valve and will avoid its premature failure.
- Using Grease other than Silicon base Molykote 33M will lead to premature failure of O Rings of the ROTEX Solenoid valve.
-  If necessary to clean the components, **do not use Kerosene, Diesel, Petrol to clean valve as this damages the O Rings and other rubber material. Instead use light Detergent Soap Solution.**
- Ensure that the components are free from dust, dirt, lint and metal burrs.
- Twisting of O Ring should be avoided. Ensure that the twist is removed before fitting matching part.
- While closing the matching part, the matching part should be pushed in a straight line. Turning motion should be avoided.
- Pinching of O Ring at the groove corner at the time of closing gland should be avoided.
- User is requested to use safe practice for maintenance.
- It is important to place the dismantled Valve Parts on a clean paper or cloth in same sequence in which you have dismantled them.
- Ensure to keep all the components of the valve separately to avoid their mixing up. The component appears to be same may have small differences which will cause malfunction if interchanged.
- In case of difficulty you should contact the Agent, Distributor or ROTEX directly.
- Using ROTEX genuine spares will **guarantee** you trouble free operation and will avoid premature failure.

(A) TO REPLACE SPOOL ASSEMBLY

- 1) Open four bolts of air deckel and pull out the same.
- 2) Open four bolts of deckel for handle and pull out the same.
- 3) Replace the necessary defective parts ensuring that Spool assly.
- 4) Fix the spool assly using correct tool.

(B) REPLACEMENT OF O RINGS

- 1) Remove all the "O" Rings.
- 2) Clean components.
- 3) Fix new O Rings applying light layer of Molykote 33M grease.
- 4) Ensure that the O Rings and other rubber parts are compatible to the media passing through the valve.
- 5) Reassemble the valve.
- 6) Check operation and leakage of the valve
- 7) Contact ROTEX in case of any difficulty.

STORING, CLEANING AND MOUNTING OF ELASTOMERS: SYNTHETIC RUBBER PRODUCTS

- Store Spool, O Ring Set in sealed polyethylene bag, kept in cool, dry, dust free area and avoid direct contact with all light sources emitting ultra violet rays, or contact with fumes, solvents, fuels, lubricants, chemicals, acids, disinfectants.
- Follow Maintenance General Instruction & specific procedures to replace O Ring set as listed above.

Contact:**ROTEX AUTOMATION LIMITED**

987/11, GIDC, MAKARPURA, VADODARA – 390010, INDIA

Tel.: +91 265 2638136, 2638746, 2638795 Fax: +91 265 2638130

E-mail: rotexbrd@rotexindia.com

Website: www.rotexindia.com