

CLAMP.KT-A.

THE CHOICE OF MODEL
CLAMP KTA1 - 2 - 3.



1	CAPACITY 1~25 TONS.
2	A STANDARD
	B MOVABLE TYPE
	C TEMPERATURE-RESISTING TYPE
3	SLIDE OF DISTANCE

- KTA series has a simple compact design-ideal for die or plates with U-cuts.
- Optional accessories such as auto-sliders are available upon request.



Dimensions.

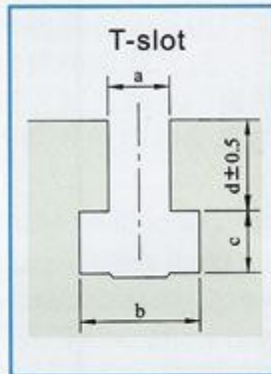
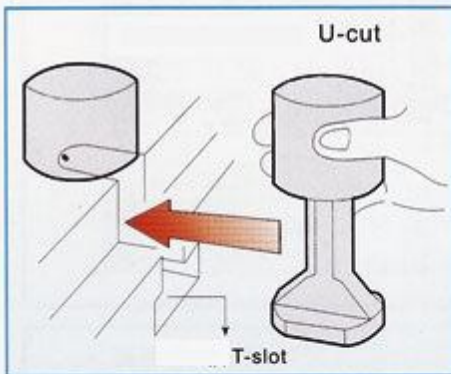
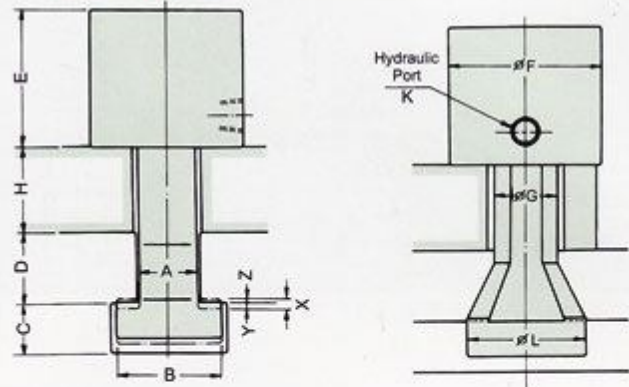

MODEL	F	E	G	L	K
KTA-1	38	37	13	30	PT 1/8
KTA-2	49	52	16	38	PT1/8
KTA-4	62	59	25	60	PT1/4
KTA-6	78	65	30	65	PT1/4
KTA-10	98	71	40	80	PT1/4
KTA-16	127	78	50	90	PT1/4
KTA-25	157	100	60	100	PT1/4

MODEL	KTA-1	KTA-2	KTA-4	KTA-6	KTA-10	KTA-16	KTA-25
Clamping force(at 250kgf/cm ²) ton	1	2	4	6	10	16	25
(X)mm Full stroke mm	5	8	8	8	8	8	8
(Y)mm Clamping stroke mm	3	5	5	5	5	5	5
(Z)mm Safety stroke mm	2	3	3	3	3	3	3
Cylinder capacity at full stroke cc	2	6.5	13	21	32	54	84

OPTIONAL AUTO-SLIDE

CLAMP

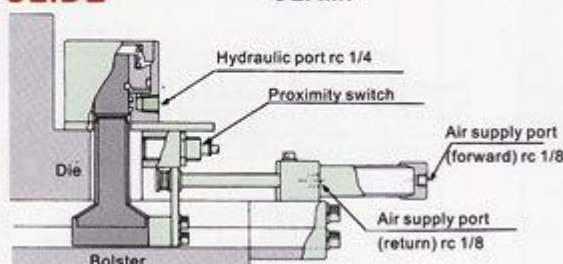

UNCLAMP

