

AIR DRIVE HYDRAULIC POWER UNIT.PV

THE CHOICE OF MODEL.

1 PV-2-D-3



1	QUANTITY OF PUMP
2	QUANTITY OF VALVE
3	A : AC110V B : AC220V C : DC24V

- Special non-leak go back design of way, oil pressure can lock for a long time, avoid lose electrical power or atmospheric pressure source when disappearing because oil pressure disappear the danger caused.
- Each valve has a press switch to shut down the press in case of accidental pressure loss, which ensures that the press can not be operated except under the rated pressure for worker and machines in safety.

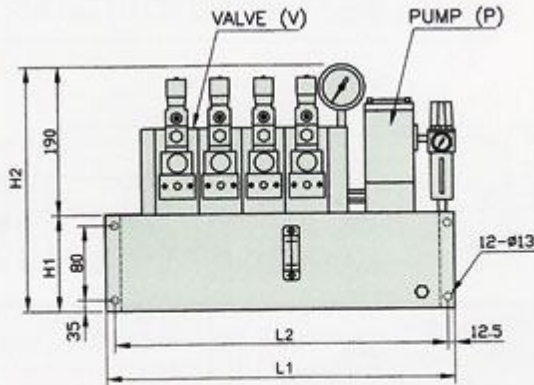

THE TYPE OF CHOISEE

MODEL	L1	L2	H1	H2
PV-D	235	210	150	340
PV-2D	294	269	150	340
PV-3D	353	328	150	340
PV-4D	412	387	150	340
2PV-4D	460	435	150	340

The picture of hydraulic control system

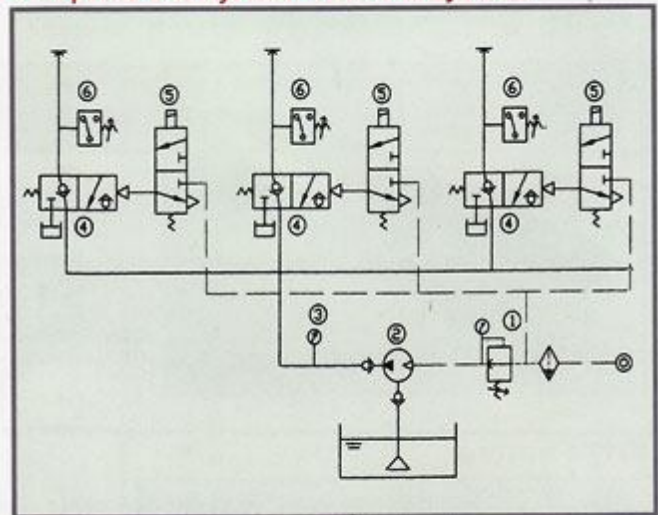

MODEL : PE



MODEL : PV-D



MODEL : PV-2D



MODEL : PV3D



MODEL : PV-4D



MODEL : 2PV-4D

