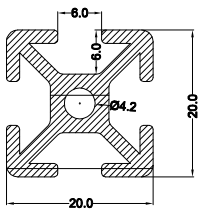
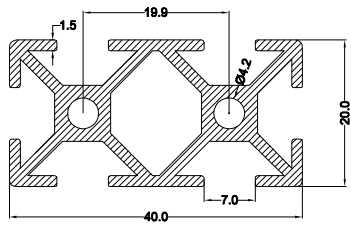
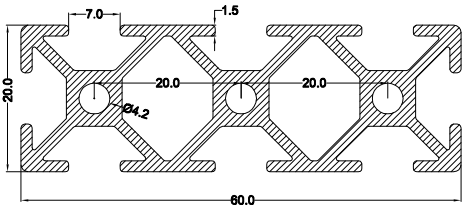
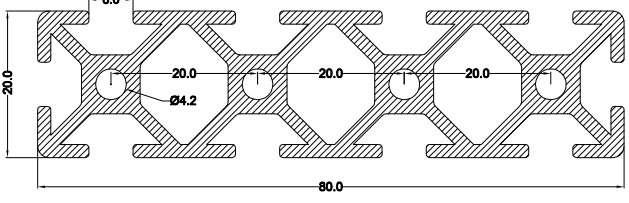
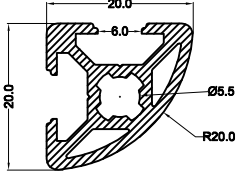
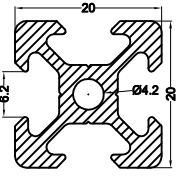

## Light Metals Catalog

### T Slotted Aluminium Profiles Catalog

## 20 x 20 Modular Profile Series

<p>SEC.NO.-300 T Slot</p> 	<p>size:- 20 X 20 mm<sup>2</sup> length:- 4.57mtr.</p> <hr/> <p>weight/mtr:- 0.480 kg/mtr.</p>	<p>SEC.NO.- 360</p> 	<p>Size:- 20 X 40 mm<sup>2</sup> length:- 4.57mtr.</p> <hr/> <p>Weight/mtr:- 0.746 kg/mtr.</p>		
<p>SEC.NO.- 419</p> 	<p>size:- 20 X 60 mm<sup>2</sup> length:- 4.57mtr.</p> <hr/> <p>weight/mtr:- 1.09kg/mtr.</p>		<p>SEC.NO.- 403</p> 	<p>size:- 20 X 80 mm<sup>2</sup> length:- 4.57mtr.</p> <hr/> <p>Weight/mtr:- 1.665 kg/mtr.</p>	
<p>SEC.NO.- 438</p> 	<p>size:- 20 X 20 mm<sup>2</sup> Corner profile length:- 4.57mtr.</p> <hr/> <p>weight/mtr:- 0.388 kg/mtr.</p>		<p>SEC.NO.- 460 V slot 20x20</p> 	<p>size:- 20 X 20 mm<sup>2</sup> V Slot profile length:- 4.57mtr.</p> <hr/> <p>weight/mtr:- 0.46 kg/mtr.</p>	

# 30 x 30 modular profile series

SEC.NO.- 212

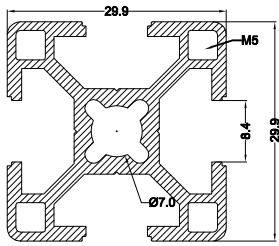

size:- 30 X 30 mm<sup>2</sup> length:- 4.57mtr.

weight/mtr:- 0.758 kg/mtr.

SEC.NO.- 351

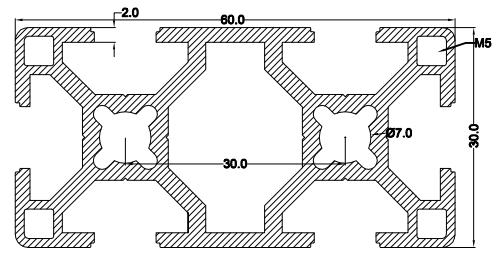

size:- 30 X 60 mm<sup>2</sup> length:- 4.57mtr.

weight/mtr:- 1.57kg/mtr.

SEC. NO.- 212M Heavy MOQ:  
300 Mtrs

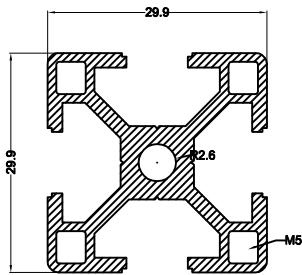

size:- 30 X 30 mm<sup>2</sup> Heavy length:- 4.57mtr.

weight/mtr:- 0.787 kg/mtr.

SEC. NO.- 436 (30 CORNER)

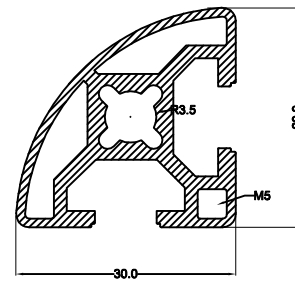

size:- 30 X 30 mm<sup>2</sup> Corner length:- 4.57mtr.

weight/mtr:- 0.701 kg/mtr.

SEC. NO.- 456

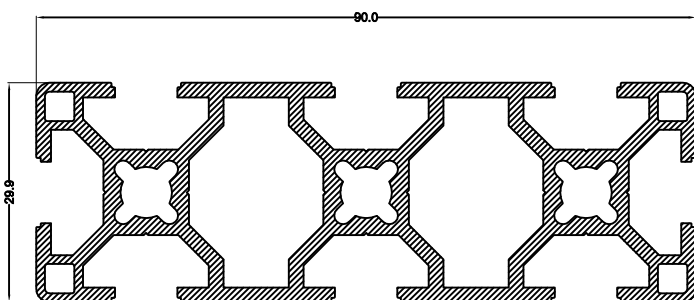

size:- 30 X 90 mm<sup>2</sup> length:- 4.57mtr.

weight/mtr:- 2.03 kg/mtr.

# 40 x 40 modular profile series

SEC. NO.- 291

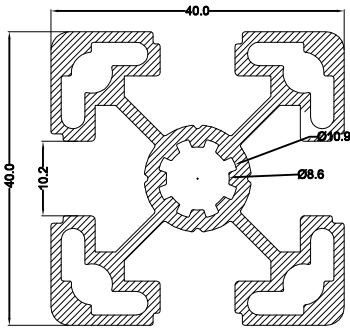

size:- 40 X 40 mm<sup>2</sup> Medium Center Round length:- 4.57mtr.

weight/mtr:- 1.35 kg/mtr.

SEC. NO.- 291 A

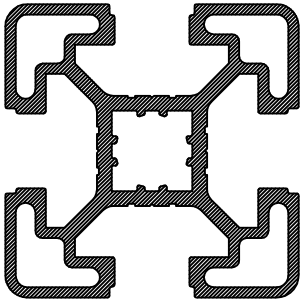

size:- 40 X 40mm<sup>2</sup> Light Center Square length:- 4.57mtr.

weight/mtr:- 1.245 kg/mtr.

SEC. NO.- 364

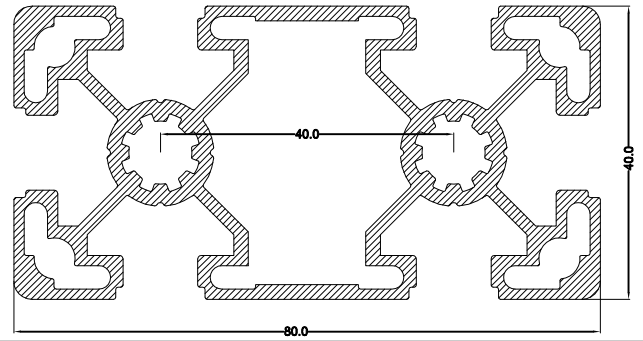

size:- 40 X 80 mm<sup>2</sup> Light length:- 4.57mtr.

weight/mtr:- 2.2 kg/mtr.

SEC. NO.- 412

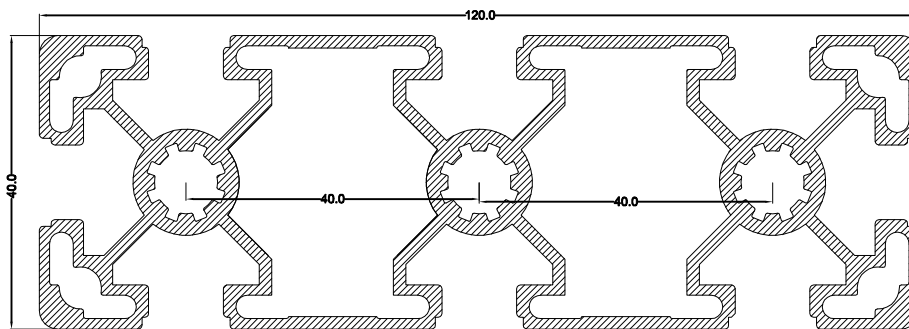

size:- 40 X 120 mm<sup>2</sup> length:- 4.57mtr.

weight/mtr:- 3.057 kg/mtr.

# 40 x 40 modular profile series

SEC. NO.- 443 40 X 80 mm<sup>2</sup> Medium)

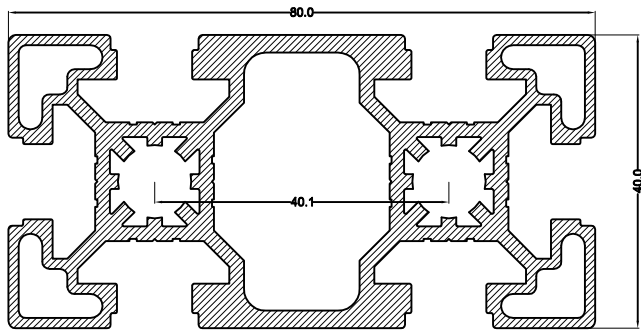

size:- 40 X 80 mm<sup>2</sup> (Medium) length:- 4.57mtr.

weight/mtr:- 2.546 kg/mtr.

SEC. NO.- 457

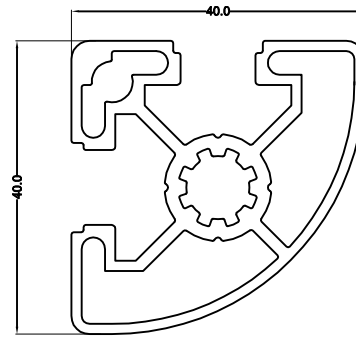

size:- 40 X 40 mm<sup>2</sup> CORNER PROFILE length:- 4.57mtr.

weight/mtr:- 1.05 kg/mtr.

SEC. NO.- 474 (HEAVY)

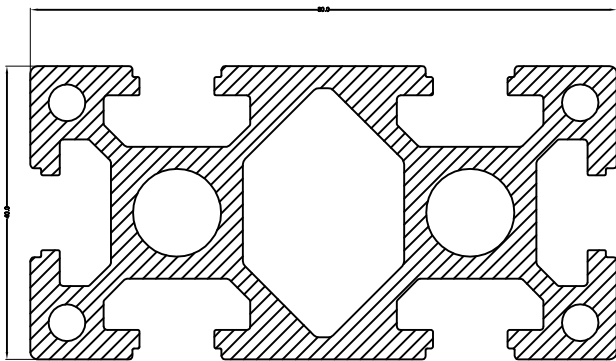

size:- 40 X 80 mm<sup>2</sup> (HEAVY) length:- 4.57mtr.

weight/mtr:- 3.5 kg/mtr.

SEC. NO.- 291B

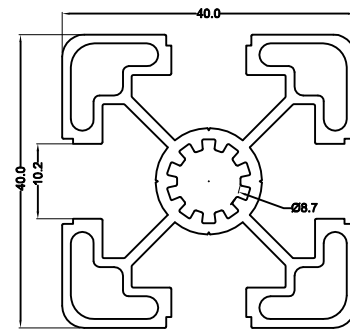

size:- 40 X 40 mm<sup>2</sup> (Light) Center Round length:- 4.57mtr.

weight/mtr:- 1.15 kg/mtr.

Sec no. 447 (SQUARE) Heavy

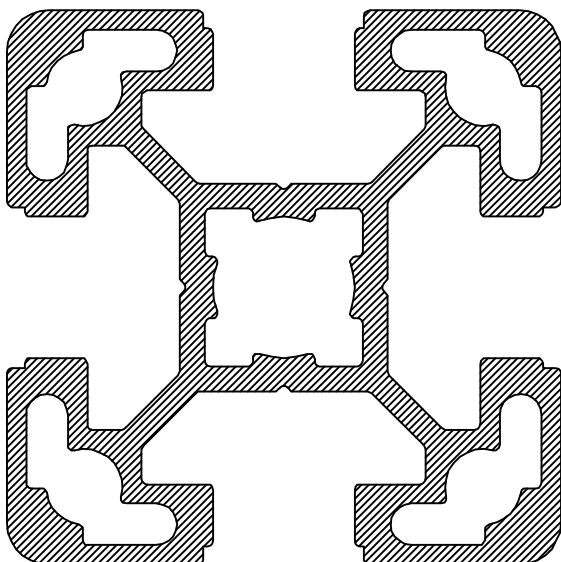

size:- 40 X 40 mm<sup>2</sup> (SQUARE) Heavy length:- 4.57mtr.

weight/mtr:- 1.670 kg/mtr.



# 45 x 45 modular profile series

SEC. NO.- 90

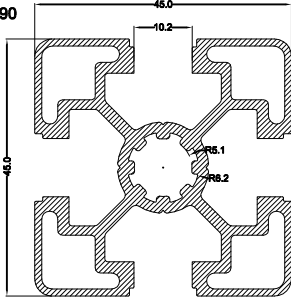

size:- 45 X 45 mm<sup>2</sup> length:- 4.57mtr.

weight/mtr:- 1.62 kg/mtr.

SEC. NO.- 477

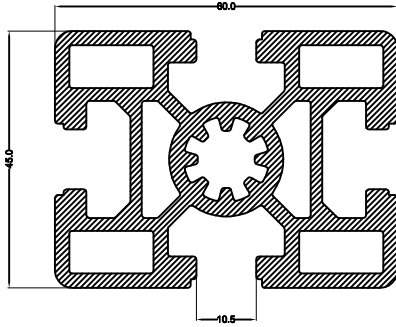

size:- 45 X 60 mm<sup>2</sup> length:- 4.57mtr.

weight/mtr:- 2.84 kg/mtr.

SEC. NO.- 350

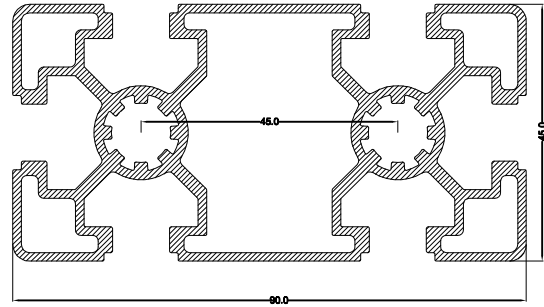

size:- 45 X 90 mm<sup>2</sup> length:- 4.57mtr.

weight/mtr:- 2.45 kg/mtr.

SEC. NO.- 428

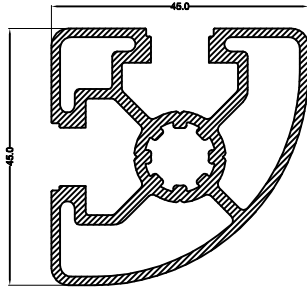

size:- 45X45 CORNER length:- 4.57mtr.

weight/mtr:- 1.22 kg/mtr.

SEC. NO.- 495

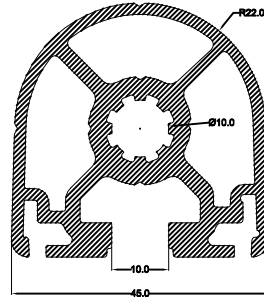

size:- 45X45 HR length:- 4.57mtr.

weight/mtr:- 1.77 kg/mtr.

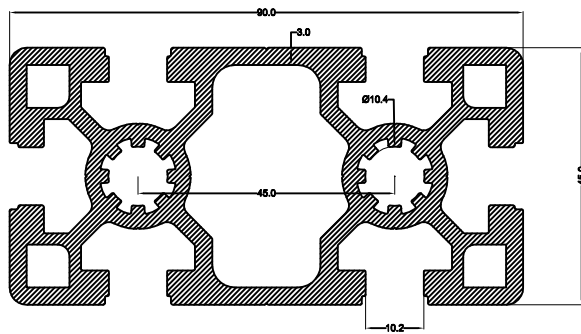

size:- 45 X 90 mm<sup>2</sup> Heavy length:- 4.57mtr.

weight/mtr:- 3.925 kg/mtr.

## 50 x 50 modular profile series

SEC. NO.- 440

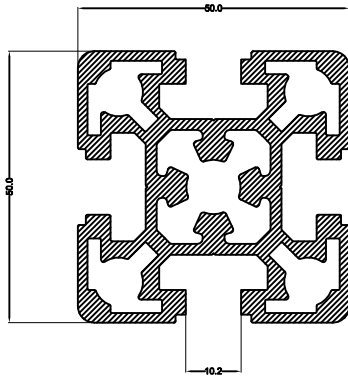

size:- 50X50 length:- 4.57mtr.

weight/mtr:- 2.55 kg/mtr.

## 60 x 60 modular profile

SEC. NO.- 374

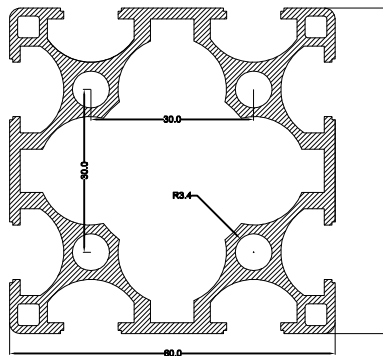

size:- 60 X 60 mm<sup>2</sup> Light length:- 4.57mtr.

weight/mtr:- 2.35 kg/mtr.

SEC. NO.- 437 60 X 60 mm<sup>2</sup> (Medium)

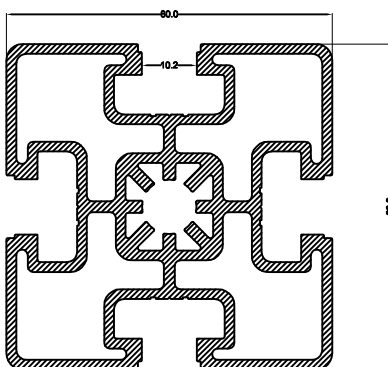

size:- 60 X 60 mm<sup>2</sup> (Medium) length:- 4.57mtr.

weight/mtr:- 2.691 kg/mtr.

SEC. NO.- 478 60 X 60 mm<sup>2</sup> (HEAVY)

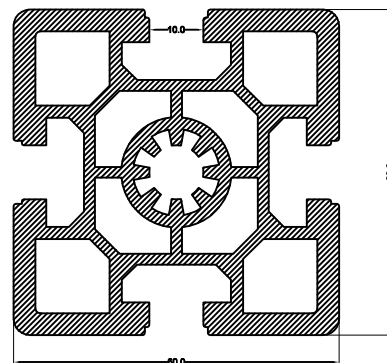

size:- 60 X 60 mm<sup>2</sup> (HEAVY) length:- 4.57mtr.

weight/mtr:- 3.9 kg/mtr.

# 80 x 80 modular profile

SEC. NO.- 475 (80x80)

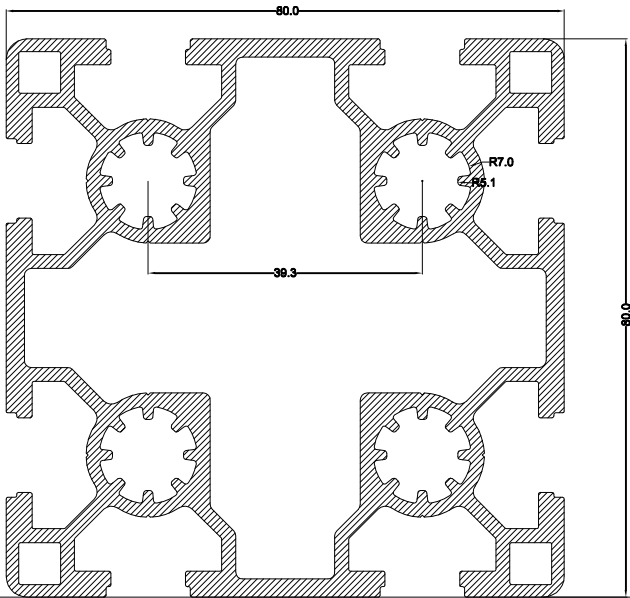

size:- 80 X 80 mm<sup>2</sup> length:- 4.57mtr.

weight/mtr:- 4.345 kg/mtr.

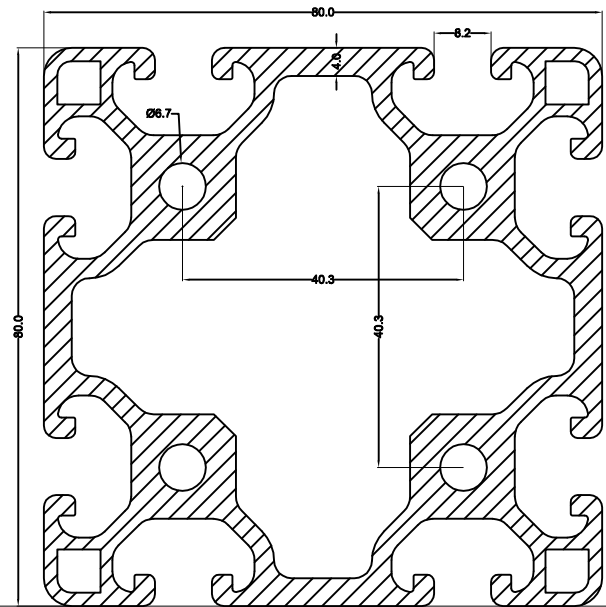

size:- 80 X 80 mm<sup>2</sup> heavy length:- 4.57mtr.

weight/mtr:- 5.54kg/mtr.

SEC. NO.- 481

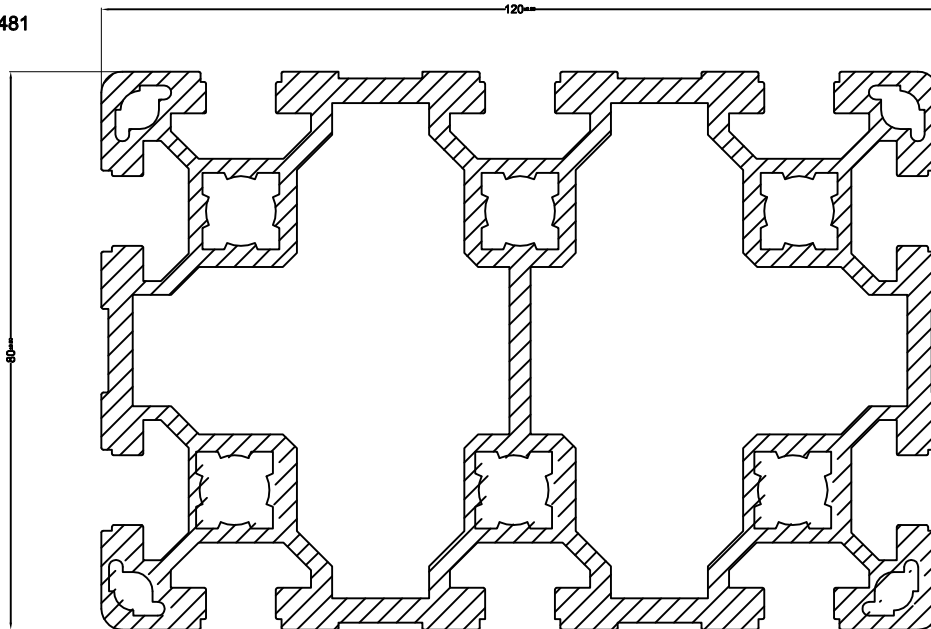

size:- 80 X 120 mm<sup>2</sup> length:- 4.57mtr.

weight/mtr:- 6.7 kg/mtr.

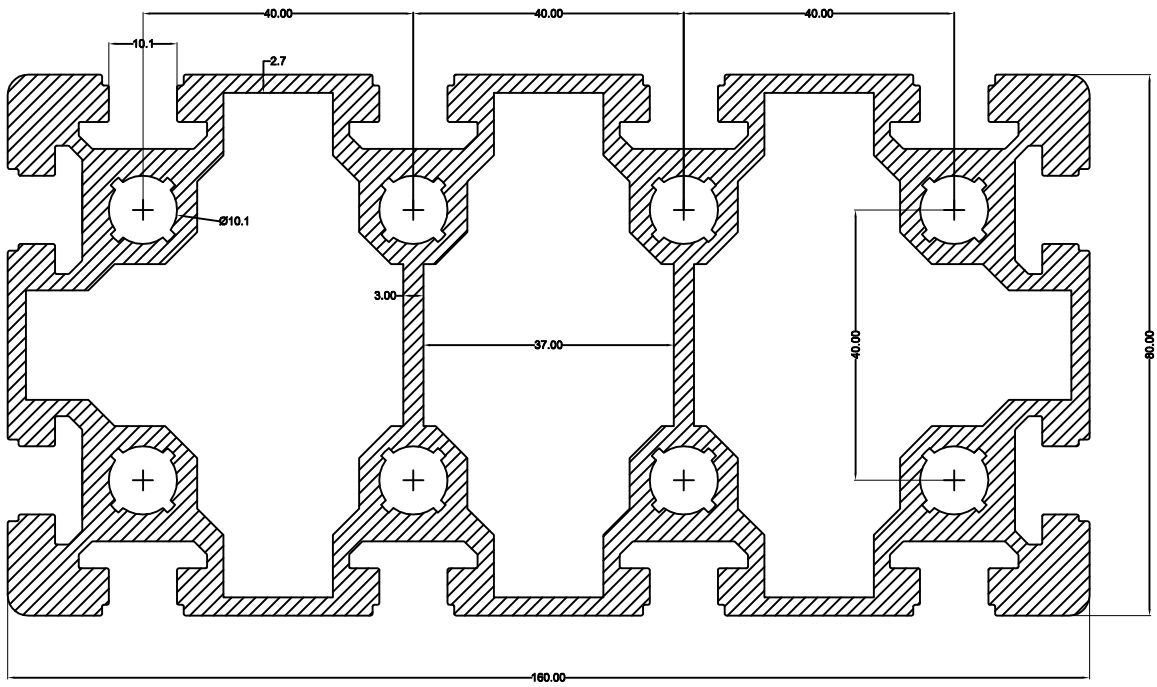

size:- 80 X 160 mm<sup>2</sup> length:- 4.57mtr.

weight/mtr:- 10 kg/mtr.

## 90 x 90 modular profile

SEC. NO.- 312

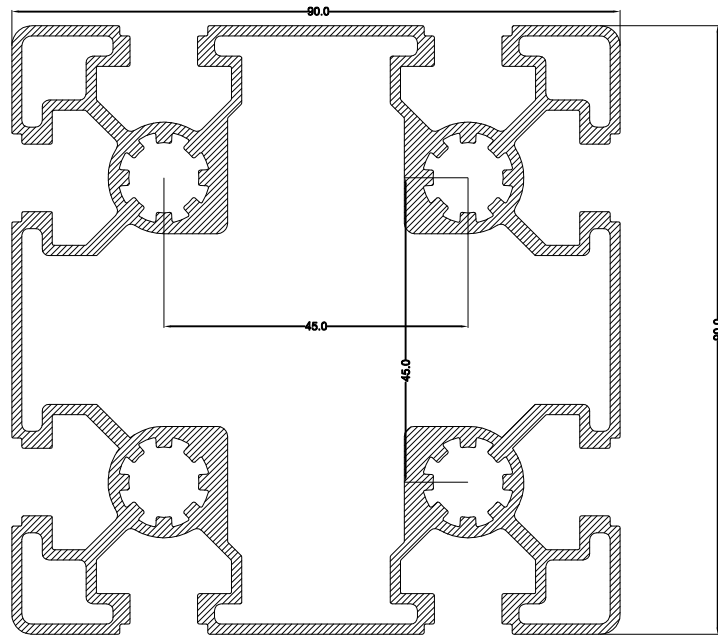

size:- 90 X 90 mm<sup>2</sup> length:- 4.57mtr.

weight/mtr:- 6.26 kg/mtr.

# Modular Accessories Retail Price List

Sl. No.	Image	Material	Retail Price		
1		<b>Die Cast Brackets</b>			
		20 x 20 External Bracket Heavy			
		20 x 20 External Bracket Imported			
		30 x 30 External Bracket Heavy			
		30 x 30 External Bracket Imported			
		40 x 40 External Bracket Heavy			
		40 x 40 External Bracket Imported			
		45 x 45 External Bracket Heavy			
		45 x 45 External Bracket Imported			
		60 x 60 External Bracket			
		40 x 80 External Bracket			
		45 x 90 External Bracket			
		80 x 80 External Bracket			
		90 x 90 External Bracket			
2		<b>Internal Brackets</b>			
		20 x 20 Inner Bracket LM			
		20 x 20 Inner Bracket (Forged)			
		30 x 30 Inner Bracket LM			
		30 x 30 Inner Bracket Forged			
		40 x 40 Or 45 x 45 Inner Bracket LM			
		40 x 40 Inner Bracket Forged			
3		<b>Grub Screw</b>			
		SS Grub screw M8 x 10			
		SS Grub screw M6 x 8			
		SS Grub screw M5 x 6			
4		<b>Hammer Type T Nuts</b>			
		M4 & M5 T Nut (20 x 20)			
		M4, M5 & M6 T Nut (30 x 30)			
		M5, M6 & M8 T Nut (45 x 45)			
5		<b>SS Button Head Grade</b>			
		SS Button Head M4 x 8			
		SS Button Head M5 x 10			
		SS Button Head M6 x 10			
		SS Button Head M6 x 12			
		SS Button Head M6 x 15			
		SS Button Head M8 x 12			
		SS Button Head M8 x 15			
		SS Button Head M8 x 20			
		SS Button Head M8 x 25			
SS Button Head M8 x 30					
6		<b>End Caps</b>			
		20 x 20 End Cap			
		20 x 40 End Cap			
		20 x 60 End Cap			
		20 x 80 End Cap			
		30 x 30 End Cap			
		30 x 60 End Cap			
		30 x 90 End Cap			
		40 x 40 End Cap			
		40 x 40 End Cap			
		40x 80 End Cap			
		40x 120 End Cap			
		45 x 45 End Cap			
		45x 90 End Cap			
60 x 60 End Cap					
80 x 80 End Cap					
90 x 90 End Cap					

7		<b>Hinges</b> Polymide Hinge DHIF 4040A DHIF 3040A DHIF 2030A DHIF 3030A			
8		<b>Levelling Base</b> Levelling Base DLB 32 M10 x 68 Levelling Base DLB 60 M10 x 68 Levelling Base DLB 45 M10 x 50 Levelling Pad DLB 60 M12 x 68 Levelling Base M16 (60x60) Levelling base DLB60 M 8 x 68 Levelling Base Plastic 20x20			
9		<b>Levelling Base Steel</b> Levelling Base M12 x 68 Steel			
10		Imported Leveling Castor 60 F			
11		<b>Black Beading 20 x 20</b> <b>Black Beading 30 x 30</b> <b>Black Beading 45 x 45 Light</b> <b>Black Beading 45 x 45 Heavy</b> <b>Blue Beading 45 x 45 Heavy</b>			
12		<b>Straight Joint</b> 40 x 40 Straight Joint 150 MM M8 & M6 40 x 40 Straight Joint 100 MM M8 & M6 20 x 20 Straight Joint (Forged) 30 x 30 Straight Joint 50 MM M6			
13		<b>External Bracket Cover</b> 45x45 External Bracket Cover			

14		<b>Flat Nut</b>			
		M5 Flat for 20x20			
		M6 Flat Nut for 30x30			
		M8 & M6 Flat Nut for 40x40			

15		<b>T Bolts</b>			
		T Bolt (M6x12) For 30x30 Profile			
		T Bolt (M8x20) For 45x45 Profile			
		T Bolt (M8x25) For 45x45 Profile			

16		<b>Connecting Plates 3mm Thickness</b>			
		'T' Plate 3mm			
		'L' Plate 3 mm			
		'Cross or Plus(+)' Plate 3mm			
		<b>Connecting Plate 5mm Thickness</b>			
		'T' Plate 5mm			
		'L' Plate 5 mm			
		'Cross or Plus(+)' Plat 5mm			

17		<b>HT BUTTON HEAD</b>			
		HT BUTTON HEAD M12x30			

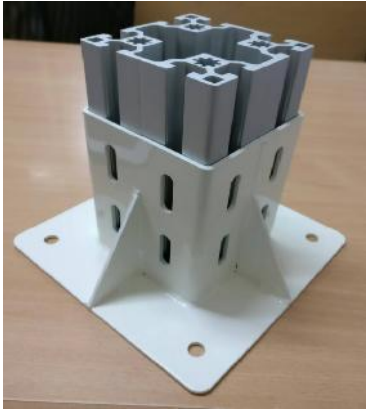
18		<b>Floor Mounting Brackets Material MS</b>			
		<b>Powder coated or GI</b>			
		90x90 Floor Mounting Brackets			
		80x80 Floor Mounting Brackets			
		60x60 Floor Mounting Brackets			

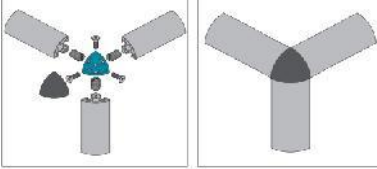
19		<b>Cubic Connector for T Slotted Profiles</b>			
		20x20 Corner Cubic Connecor			
		20x20 Square Cubic Connecor			
		30 Series 3 Way Joint Set (30 Corner)			
		30 Series Cubic Connector 30x30 Square			
		45 Series 3 Way Joint Set (45 Corner)			
		45 Series Cubic Connector 45x45 Square			

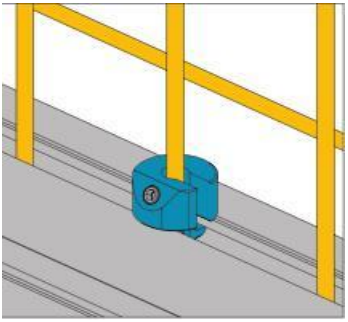
20		<b>Mesh Mounting Block</b> Mounting Block for 30x30 Mounting Block for 45x45			

QUOTE FOR ACCESSORIES ON REQUEST

We offer Exhibition Stalls to the corporate organisations or companies who intends to participate in big fairs, exhibition or trade fair which help to build the brand. We are specialized in designing and setting up a stall keeping all the amenities in consideration. We know the art of creating designs which is unique and different and represent the organisation in just right way. We are also focused in designing customized design exhibition stall.

Please find Next Page of Exhibition & Accessories Catalog

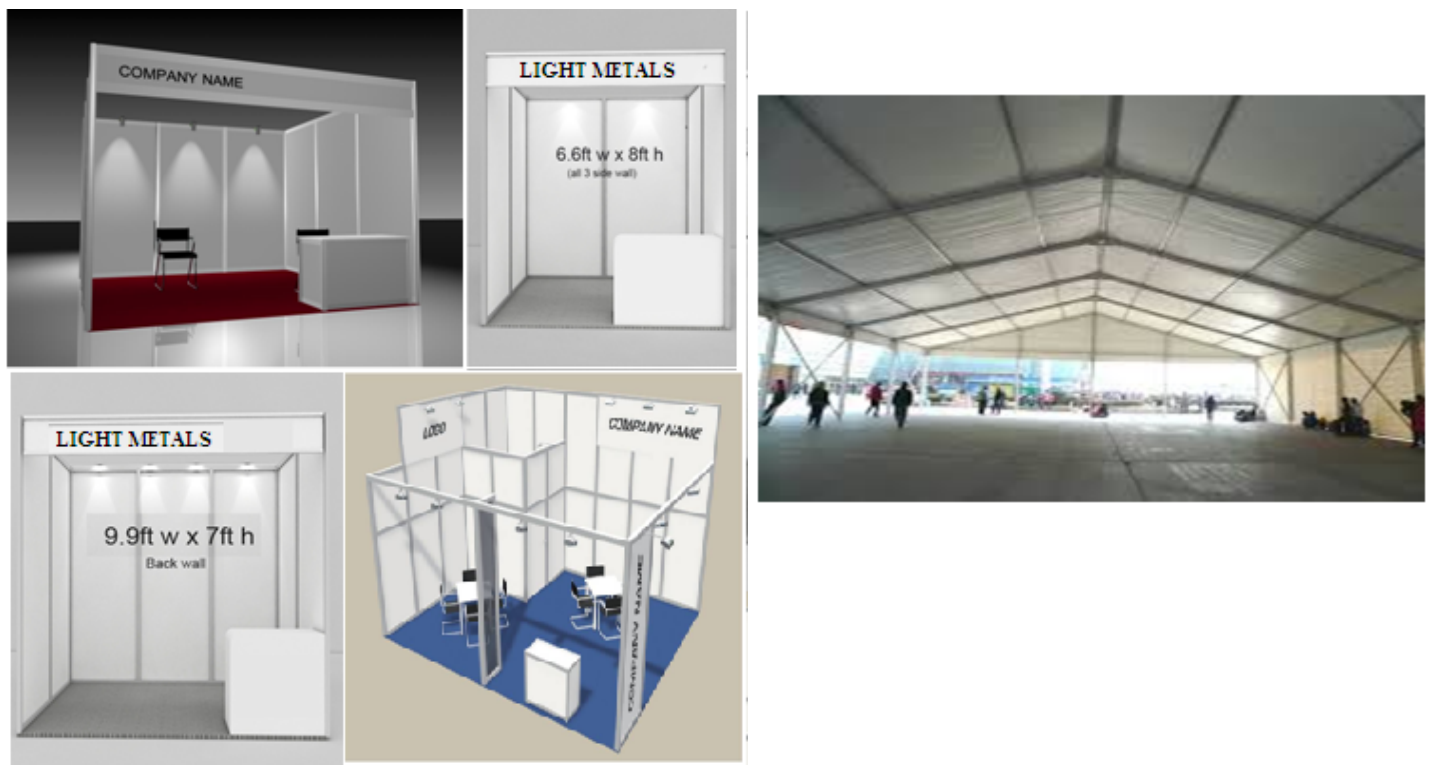



**M/s. Light Metals**  
 #148/1, 11th 'C' Cross,  
 (West of Chord Road), 2nd Stage,  
 Mahalakshmi Puram, Bangalore-560086,  
 Karnataka State, INDIA  
 Tele Ph: 080-23598244, Mob: 9845497215  
 E-mail: lightmetals2@gmail.com









4	<b>GERMAN TENTS IMAGES</b>	<b>GERMAN TENT</b>	
		<p>These design characteristics include fully interchangeable components, which can be used throughout the various different designs options available within the Tent marquee system. This functional compatibility of components enables, ease of handling, ease of storage, ease of transportation and as well as providing the user speedy assembly times all of which make the Tent marquee system the number one entry level system.</p> <p><b>GERMAN TENT</b> Standard . Extension as desired 1. 40 wide x 100 ft Length :- 2. 60 wide x 100 ft Length :-</p>	

5	<b>2 Mtr x 2 Mtr OCTORNAM STALL IMAGE</b>	<b>2 Mtr x 2 Mtr OCTORNAM STALL</b>	
		<p><b>2 mtr x 2 mtr Octornam Stall (3 mm Panel)</b> 1st Stall Additional Stall</p>	

6	<b>2 mtr x 3 Mtr Octornam Stall IMAGE</b>	<b>2 mtr x 3 Mtr Octornam Stall (3 mm Panel)</b>	
		<p>1st Stall Additional Stall</p>	



# EXHIBITION ACCESSORIES

Sl No	Picture	Description
1		<p><b>Raiser for 80x80 maxima</b></p>
2		<p><b>Sec No. 164</b></p>
3		<p><b>Lock set for 80x80 Maxima</b></p>
4		<p><b>Sec No.121</b> Aluminium Channel</p>

5		<p><b>Sec No.120</b> Pillar/ Danda</p>
6		<p><b>Exhibition Section</b></p>
7		<p><b>Sec No. 241</b></p>
8		<p><b>Sec No.237</b></p>



9

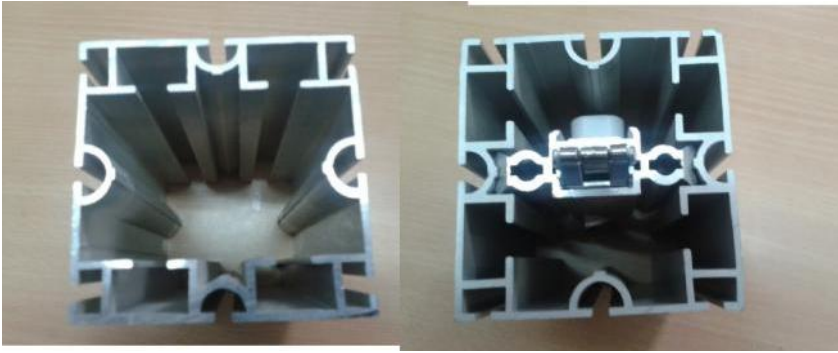

**Sec No.236**

10



**High rise tension lock for 40x40 maxima**

11



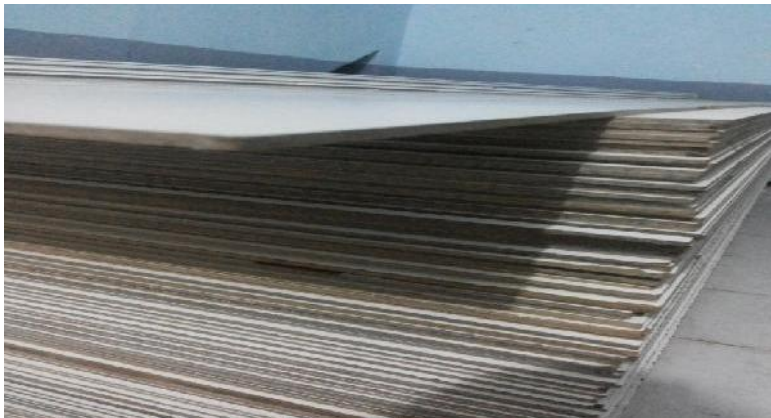

**Regular tension lock**

12



**8/4x3MM THICKNESS, HALF WHITE, PARTITION SHEETS**

13		Sec No. 326, D Section
14		Plastic Lock / Plastic Connector
15		<p><b>44x 24 inches x 20mm table top laminated. stand size (950 x 455 x 740).</b></p> <p>A) With Post Formed Table Top b)With out Post Formed Table Top</p>

Backed by the years of experience and knowledge, we are engaged in manufacturing, exporting and trading a wide range of Modular Sign Systems

Please check the Signages catalog Below







4		(side Track)		
		(Center/devider Track)		

**Note:**

- 1) Taxes: GST@18%
- 2) Packing, Forwarding & Transportation Charges: Extra at actual: To pay basis.
- 3) Price clause: The above prices are based on the current rate and other levies on aluminum metal. Any increase in the price of aluminum metal and other inputs / levies will be to buyer's account on The date of dispatch irrespective of delivery period agreed/ specified.
- 4) Payment: 100% advance against Proforma before dispatch.

Knowing us as a promising company, we are also engaged in manufacturing, exporting and trading a quality range of Aluminium Sections for Solar Mounting Structure. All these sections are well designed and are highly demanded by our customers. We are offering these products at affordable rates.

Please Check Below Solar Sections Catalog.





5	<b>End Cap</b>	<b>End Cap</b>	
		End Cap for 45x45 Profile Retail	
		End Cap for 45x45 Profile MOQ 500 No's	
6	<b>SS Button Head</b>	<b>SS Button Head</b>	
		SS Button Head M8x12 Retail	
		SS Button Head M8x12 MOQ: 500 No's	
		SS Button Head M8x15 Retail	
		SS Button Head M8x15 MOQ: 500 No's	
7	<b>T Nuts</b>	<b>Hammer Type T Nut</b>	
		Hammer Type T Nut M8 & M6 for 45x45 Profile Retail	
		Hammer Type T Nut M8 & M6 for 45x45 Profile MOQ: 100 No's	
		Hammer Type T Nut M8 & M6 for 45x45 Profile MOQ: 500 No's	
8	<b>Solar Panel Mounting U Bracket</b>	<b>Solar Panel Mounting U Bracket (MID Clamp)</b>	
		Solar Panel Mounting U Bracket Anodized (MID Clamp) (50 mm length)	
9	<b>Solar Panel Mounting Z Bracket</b>	<b>Solar Panel Mounting Z Bracket (END Clamp)</b>	
		Solar Panel Mounting Z Bracket Anodized (END Clamp)	

Quote On Request

**Please Note: Prices prevailing at the time of delivery will be applicable.**

**M/s. Light Metals**  
#148/1, 11th 'C' Cross, (West of Chord Road),  
2nd Stage, Mahalakshmi Puram,  
Bangalore-560086,  
Karnataka State, INDIA  
Ph: 080-23598244, Mob: 09845497215  
E-mail: lightmetals2@gmail.com

**HANDLE SECTIONS CATALOG**

Sl. No.	Image	Description	Price
1		<b>Aluminium G Handle Hollow</b>	
		Aluminium G Handle Hollow (10 feet) Anodized	
2		<b>Aluminium G Handle Solid</b>	
		Aluminium G Handle Solid (10 feet) Anodized	
3		<b>Aluminium Blum handle</b>	
		Aluminium Blum handle (12 feet) Anodized	
4		<b>Ward Robe Section Top &amp; Bottom</b>	
		Ward Robe Section Top & Bottom 8 Feet	
		Ward Robe Section Top & Bottom 12 Feet	

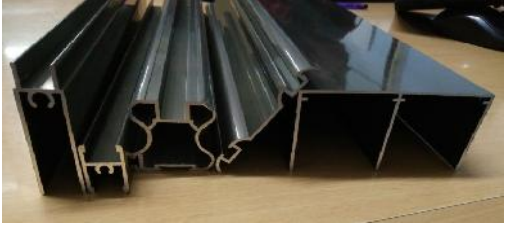
5	<b>Sliding Ward Robe Sections</b>	<b>Sliding Ward Robe Sections</b>	
		<b>Quote On Request</b>	