



54, Annapurna Industrial Estate, Tilak Road,
Ghatkopar (E), Mumbai - 400 077 India
Tel: +91-22-21029911
E-mail: sales@excellaelectronics.com



BLDC MOTOR

BRUSHLESS DC MOTOR RANGE

BLDC Motor Technical Details: FRAME 23 & 36

BRUSHLESS DC MOTOR RANGE								
Model No.	Watt	Speed	Torque	VDC	Motor Dimension	Amp.	Shaft	Appr. Weight
ET-2360L-24	60	1500/ 3000	4 Kg./ 2 Kg.	12, 24	Dia-60, L80	5, 2.5	Dia-12, L-27	1.2 Kg.
ET-23100L-24	100	1500/ 3000	8 Kg./ 4 Kg.	24	Dia-60, L80	4.5	Dia-12, L-27	1.2 Kg.
ET-36200-24	200	1500/ 3000	13 Kg./ 6 Kg.	24, 36, 48	Dia-140, L140	8.5, 5.5, 4.5	Dia-11, L-23	2.2 Kg.
ET-36400-24	400	1500/ 3000	26 Kg./ 13 Kg.	24, 36, 48	Dia-140, L140	16.5, 12, 8.5	Dia-11, L-23	2.6 Kg.
ET-36600-24	600	3000	20 Kg.	24, 36, 48	Dia-140, L140	25, 16.5, 12.5	Dia-11, L-23	2.6 Kg.



Mechanical Dimension

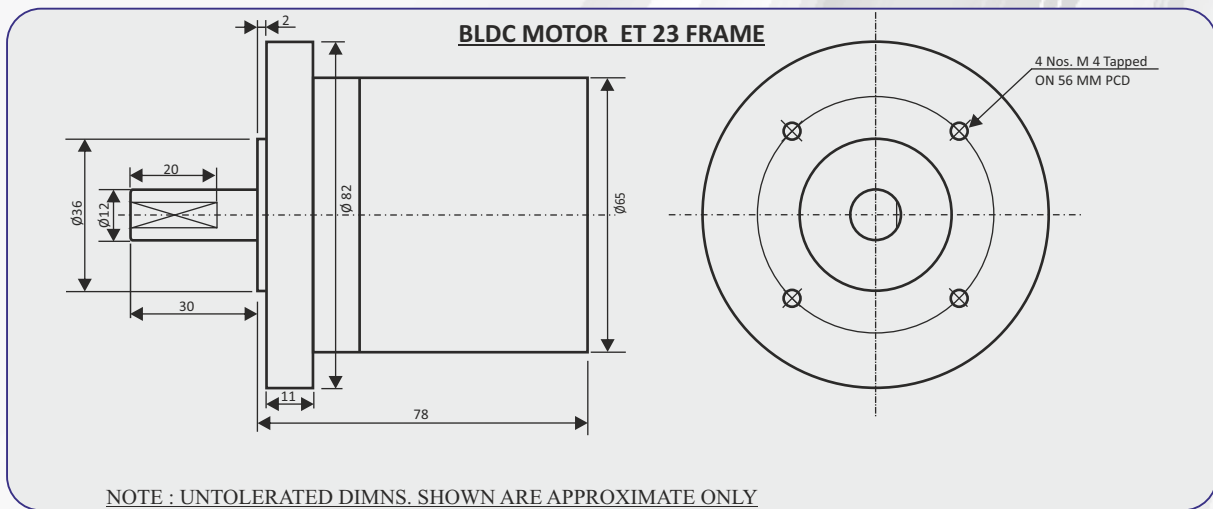

Mechanical Dimension

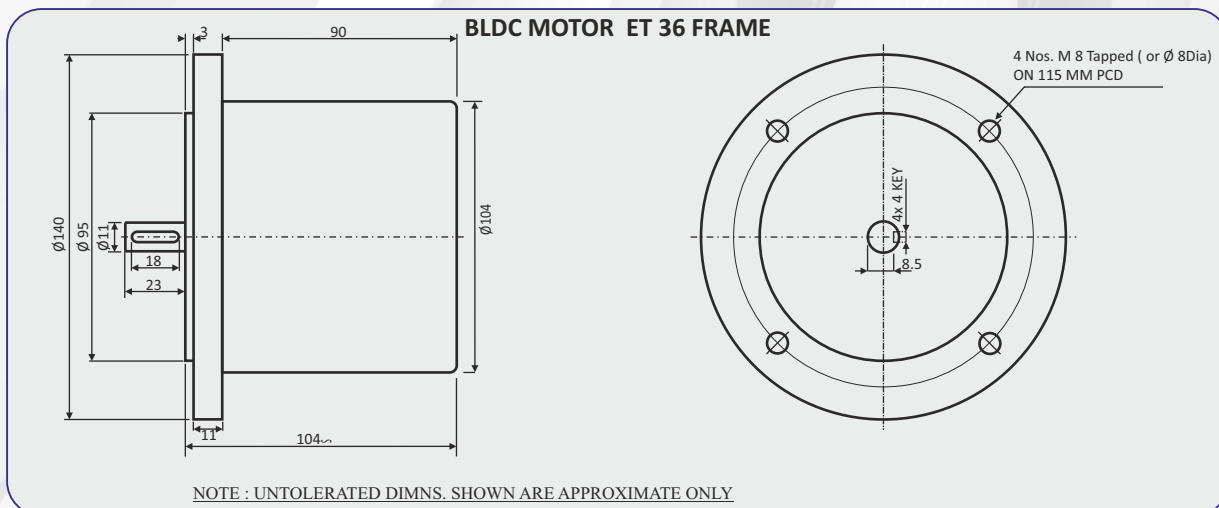



BLDC MOTOR CONTROLLER (DRIVE)

FEATURES :

- Sensored drive in three -phase full wave mode.
- PWM chopper control.
- Controls the PWM duty cycle, Based on an analogue point.
- Output Current: 20A max.
- Improved Torque & response due to sensored operation.
- Excellent low speed response due to sensored operation.
- Forward & Reverse Rotation.
- Motor Brake function.
- All input protected for over voltage / short.
- Tacho output provided for feedback control.

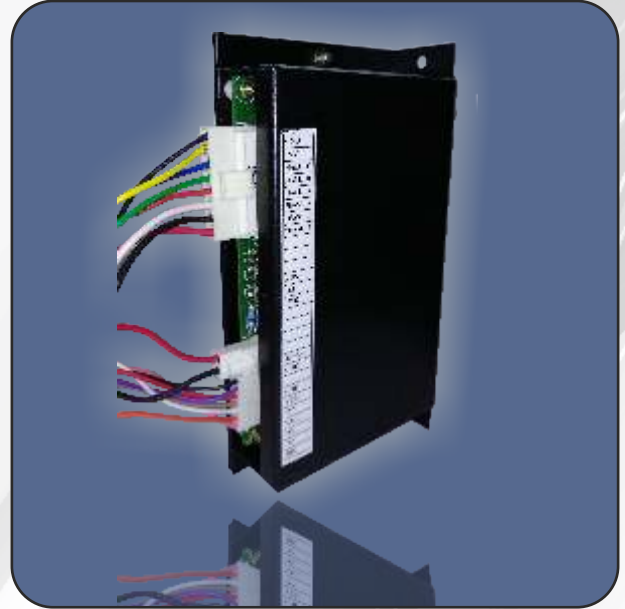

TECHNICAL DETAILS:

- | | | |
|------------------------------|---|---|
| • Power | : | 25 Watt to 2 K Watt. |
| • Voltage operating range | : | DC: 24/ 36/ 48/ 110 V & AC: 230VAC, 50Hz |
| • Current Limits | : | Up to 20 Amp |
| • Voltage Range of Speed Pot | : | 0 - 4.5 V |
| • Drive Control | : | Forward / Reverse / Enable / Disable / Running. |
| • LED Indicator | : | Power Indicator, Run Indicator, Error Indicator |