

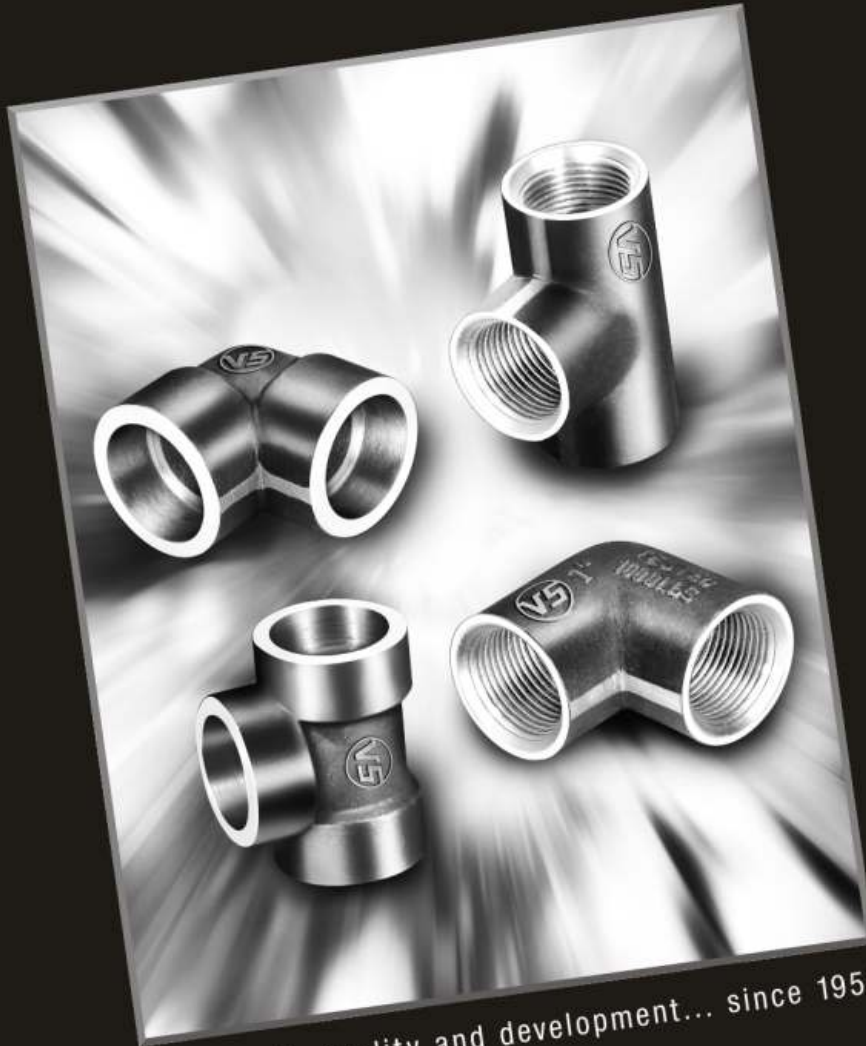

THE NO. 1
FORGED STEEL
PIPE FITTINGS



harmony in quality and development... since 1950





Late Mr. Harbans Lal Sharma
(2.2.1920 - 2.12.2002)
Founder
Vijay Cycle & Steel Industries

HARMONY IN QUALITY AND DEVELOPMENT... SINCE 1950

Vijay Cycle & Steel Industries today is paramount in the Forged Steel Pipe Fittings manufacturing Scenario in India, this company was Conceptualized by Late Sh. Harbans Lal Sharma an Ex. Indian Air Force Officer way back in 1950.

He was a Visionary of remarkable Clarity with a heart of Gold. The present management owes its success to the seeds sown by him, one of which is ; HR International' 'the Hand Tools Company', this segment was experiencing an unprecedented boom with unmistakable pointers to an exponential growth fuelled by rising global demand.

Fulfilling the Dreams & Vision of their legendary Founder are his three heirs Sh. Sudarshan Shurma, Sh. Suresh Sharma & Sh. Naresh Sharma, who together

with a team of highly professional people loaded with Sound Technical Knowledge and abundant experience in various relevant fields are running business at a scorching pace and giving products with unmatched quality and maintaining an everlasting relationship with their esteemed customers.

Our Inspiration to be **No.1** comes through our actions towards product excellence leaving our Competition for wholehearted and solid support of our worthy Customers who placed us on the top pedestal. We will always live upto their expectations and strive to attain perfection and continue growing from strength to strength, year after year.



Sudarshan Sharma
Managing Director



Suresh Sharma
Director



Naresh Sharma
Director



Sushant Sharma
Director



Rishi Raj Sharma
Director



Shivam Sharma
Director

MESSAGE FROM THE MANAGING DIRECTOR

Vijay Cycle and Steel Industries is a renowned name in the field of Forged Steel Pipe Fittings in the Indian Sub-Continent and has been manufacturing Top of the Line Products for over five decades. We are Committed to Quality and Customer's Satisfaction ever since our Inception in 1958.

We have a large Dealers Network spread across the length and breath of India whose valued & continued Support has helped us to achieve New Heights of Success which Inspires us to do better Year after Year. We are supplying our products to Refineries, Petrochemical Industry, Railways, Indian Marine shipyard, Large, Medium, Small Scale Industries and Commercial Units in India.

Dear Customer, You are our Real Strength and we are Thankful to you for bringing our Company to the Forefront of Indian Industry. We assure you of our

Commitment to implement and maintain High Quality Standards dedicated to your Total Satisfaction. We look forward with Great Interest in building new business relationships and to expand our horizons for a better tomorrow.

You are All Cordially invited to Please Come and Join us in our endeavor to lift Indian Industry to the Highest Pedestal, edge out Global Competition and provide a better platform to our Future Generations to World Leaders in Entrepreneurship & Business.

I once again Thank You for your whole Hearted Support and Faith Bestowed Upon Us.

Thank You

SUDERSHAN SHARMA
(Managing Director)

INNOVATIVE Technique for Customised Solutions

Our Production Facilities

Match International Standard

We at Vijay Cycle & Steel Industries continuously aim in giving Customised Solutions as far as Manufacturing and delivery is Concerned. Building upon our humble beginnings, we have, with time changed our production facilities and added State of the Art Machinery, in die making, machining, Leak-Testing and Packaging. We have Incorporated Quality Standards on the Shop Floor aiming at a durable Product. Systematizing the working environment and improving the very lives of our working team benefitting one and all.



C.N.C. Die Making Machine

Production Facilities

- Die Making
- Forging
- Machining
- Testing
- Packaging



Cad/Cam System



Forging Section

**World Class
Infrastructure,
R&D,
Human Resourcing**



Testing Lab

Vijay Cycle and Steel Industries has the State of the art infrastructure, latest machines for Die making, Forging, Machining, Testing and R & D Our Product line includes a wide range of Forged Steel Pipe Fittings for use in Industrial and Commercial establishments.

The Product designing is done on advanced **CAD/CAM Systems**.

Initially the incoming raw material is tested for Chemical & Physical Conformity to Standards in a well Equipped Test Lab where we also carry out our R & D activities.

The Steel is Forged on precision Forging Presses and friction Drop Hammers. These Forgings are then machined on the latest **CNC & SP** machines.

We have an excellent facility for Manufacturing and Packaging which matches Global Standards in Quality and Safety.

Our Assets include a dedicated manpower team together with advanced machinery which makes us **number ONE** in Forged Steel Pipe Fittings in India. We are also the **First** in attaining **ISO 9001:2008** and **ISO 14001:2004** certification.

For us it is a matter of great pride that through our products we happen to be part of the Industrial and National Chain of Growth.



Forging Section



Machine Shop



GROUP OF INDUSTRIES



VIJAY CYCLE & STEEL INDUSTRIES

Vijay Cycle and Steel Industries is a renowned name in the field of Forged Steel Pipe Fittings in the Indian Sub-Continent and has been manufacturing Top of the Line Products for over five decades. We are Committed to Quality and Customer's Satisfaction ever since our Inception in 1958.

We have a large Dealers Network spread across the length and breath of India whose valued & continued Support has helped us to achieve New Heights of Success which Inspires us to do better Year after Years. We are supplying our products to Refineries, Petrochemical Industry, Railways, Indian Marine shipyard, Large, Medium, Small Scale Industries and Commercial Units in India.

Dear Customer, You are our Real Strength and we are Thankful to you for bringing our Company to the Forefront of Indian Industry. We assure you of our Commitment to implement and maintain High Quality Standards dedicated to your Total Satisfaction. We look forward with Great Interest in building new business relationships and to expand our horizons for a better tomorrow.

You are All Cordially invited to Please Come and Join us in our endeavor to lift Indian Industry to the Highest Pedestal, edge out Global Competition and provide a better platform to our Future Generations to World Leaders in Entrepreneurship & Business.

Once again Thank You for your whole Hearted Support and Faith Bestowed Upon Us.



HR INTERNATIONAL (UNIT I)

H.R. International, a part of 'VS' Group of Industries, a renowned name in the professional Hand Tools market, has been manufacturing high-class Hand tools from day one and will continue with its efforts to maintain this quality level to create a longlasting relationship with its international customers. The entire team associated with this company has one common goal, and that is, Superb Quality & Customer Satisfaction.

Quality, integrity, ethics and commitment have been the mottos of our company all these years, and have been our guiding philosophy as an organisation. We have identified and chiselled our core strengths, to fulfill newer roles in the changing business environment. Investments in state-of-the-art Technology, Manpower Training, Research & development - our endeavours are totally customer-centric as we constantly strive to deliver excellence and efficiency to the best of their satisfaction.

I am highly thankful to all our worthy customers for their continuous and valuable support and I look forward with great interest to new business relationships. Come, join us and I am sure you will feel that you have made the right choice.



HR INTERNATIONAL (UNIT II)



PROXIMA STEEL FORGE PVT. LTD.

Proxima Steel Forge Pvt.Ltd., a part of 'VS' Group of Industries, was established in 1992. Its eminence has indeed grown manifold. The company's manufacturing based in Jalandhar has put it as a bright spot on the World map of Hand Tool Manufacturers.

Company is engaged into manufacturing of world class striking tools i.e. Non Sparking Brass Hammers, Hammers, Axes, Bolster & Chisels, Wrecking Bars etc.

Company is spread over in the area of 10,000 square yard with manufacturing capacity of approx. 6000 ton per annum with five Drop Hammers (maximum capacity - 3 tons Drop Hammer).

Company's products are already being marketed in several countries like Europe, USA, UK, Africa , Middle East, South East Asia, South Asia. Our Company's has Certificates of VPA GS for German Market , BS for UK Market. We are also FSC certified company and with this we have achieved sales target 200% every years.



FOODCOAST INTERNATIONAL

Foodcoast International is a part of 'VS' Group of Industries and is into manufacturing of processed food products like mayonnaise, ketchups, sandwich spreads, dips, gravies, pastes and crushes for both Indian and world cuisines under the brand name FOODCOAST. The company was established in 2009 as a trading unit. We initiated with a pilot setup in 2010 and now are spread over an area of 12000 sq meters. The prime focus of the company has been on food service sector and HoReCa since inception. The company is also selling through modern trade in stores such as Metro, Walmart, Auchan and Reliance. The effort and team work of more than 500 distributors together with our employees has helped Foodcoast to grow remarkably.



An ISO 14001:2004 Certified Co.

THE NO.1 FORGED STEEL PIPE FITTINGS



Indian Register Quality Systems
(A Department of Indian Register of Shipping)
52A, Ad Shankaracharya Marg, Opp. Powai Lake, Powai, Mumbai - 400 072, India



ACCREDITED BY THE RvA



Certificate Of Approval

This is to certify that the Environmental Management System of

Vijay Cycle & Steel Industries
A-8 & A-9, Focal Point, Jalandhar - 144 004

has been found to conform
to the requirements of the Standard:

ISO 14001 : 2004

with respect to the following scope:

**Manufacture and Supply of
Forged Steel Pipe Fittings & Forged Parts**

This Approval is subject to continued satisfactory maintenance of the Environmental Management System of the Organization to the above Standard, which will be monitored by IRQS

Certificate No.: IRQS/1330194 granted on: 2nd April 2013
Current Certification Effective Date: 2nd April 2013

C. Sriramamurthy
C. Sriramamurthy
Chief Surveyor & Senior Vice President

The use of the Accreditation Mark indicates accreditation with respect to activities covered by the certificate with accreditation no. C 071
Conditions overleaf

An ISO 9001:2008 Certified Co.



THE NO.1 FORGED STEEL PIPE FITTINGS



CERTIFICATE OF APPROVAL

Issued by Indian Register Quality Systems
(A Division of IRCLASS Systems and Solutions Private Limited)

This is to certify that the Quality Management System of

Organisation: Vijay Cycle & Steel Industries
Address: A-8 & A-9, Focal Point,
Jalandhar - 144 004,
Punjab

has been assessed and found conforming to the following requirement

Standard Certified: ISO 9001:2008
Scope: Manufacture and Supply of Forged
Steel Pipe Fittings and Forged Parts

Certificate No.: IRQS/1510303 granted on: 13th March 2015

Originally Certified: 20/03/2012 Current Issue Date: 20/03/2015



Indian Register Quality Systems

Shashi Nath Mishra

Head IRQS

This approval is subject to continued satisfactory maintenance of the Quality Management System of the organization to the above standard, which will be monitored by IRQS. The use of the Accreditation Mark indicates accreditation with respect to activities covered by the certificate with accreditation no. C071
Head Office: 52A, Adi Shankaracharya Marg, Opp. Powai Lake, Powai, Mumbai - 400 072, India.



Engineers India Limited

THE NO.1 FORGED STEEL PIPE FITTINGS

इंजीनियर्स
इंडिया लिमिटेड
(भारत सरकार का उपक्रम)

ENGINEERS
INDIA LIMITED
(A Govt. of India Undertaking)

पंजीकृत कार्यालय : इंजीनियर्स इंडिया भवन, 1, भीकाजी कामा प्लेस, नई दिल्ली-110066
Regd. Office : Engineers India Bhavan, 1, Bhikaiji Cama Place, New Delhi-110066

Procurement Development Department

24th March, 2014

Ref: 4994/PDD/I/EN/157

M/s Vijay Cycle & Steel Industries
A8-A9, Focal Point
Jalandhar - 144 004

Subject : Enlistment with EIL

Dear Sirs,

We refer to your request on subject matter and are pleased to inform that you have been enlisted with EIL for the items as described below:

Item Description	Material / Range
Forged Fittings as per IS 1239	Size : 0.5" to 4"

(This enlistment is valid for your works located at A8-A9, Focal Point, Jalandhar - 144 004).

Please note that this enlistment is subject to satisfactory execution of orders in delivery and quality of above mentioned items when ordered for our various projects.

Further, it may be noted that any change in the product range, location of Works/Sales Office, Management/ Organisation structure etc. shall be intimated to us immediately along with relevant document for our necessary action. In case, information to any of the above referred changes is not intimated timely, our enquiries may not reach you.

Enlistment with EIL shall not guarantee any regular flow of enquiries.

In the event of direct / indirect orders for EIL associated projects, materials will be supplied strictly as per the material / range / works as stated above including agreed responsibility matrix, if applicable, failing which your enlistment with EIL is liable to be cancelled.

You are advised to apply for revalidation "on-line", 6 months before expiry of the enlistment. Detailed procedures for revalidation can be seen on our website www.engineersindia.com.

Thanking you,

Very truly yours,

(Rajeev Kumar)
Dy. General Manager
Procurement Development Department

उत्कृष्टता का आधार - हमारे कर्म

फोन/Phone : +91-11-26762121 (EPABX)

Visit us at <http://www.engineersindia.com>

हिन्दी देश की एकता की कड़ी है।

DELIVERING EXCELLENCE THROUGH PEOPLE

फैक्स / Fax : +91-11-26187622

E-mail : pdd@eil.co.in



Technical Aspects

We take great pride in manufacturing Forged Steel Pipe Fittings in accordance with recommended Standard Specifications.

- (1) **ASME B.16.11-2011 / IS 4712:2011** for Forged Steel High Pressure Pipe Fittings with Socket Welding & Threaded End Connections. We use the finest Quality of steel Suitable for Forged Steel High Pressure Socket Welding & Threaded Fittings.

The End Connection of these fittings are throughly Checked using Calibrated **Plug Gauges, Thread Plug Gauges** and are leak Tested at **2000 PSIG hyd., 3000 PSIG hyd., 6000 PSIG hyd. Threaded fitting is available in - NPT, BSPT & BSP Threaded End Connections.**

Socket Weld Fittings are checked using plug Gauges and leak tested at 3000 PSIG hyd., 6000 PSIG hyd., 9000 PSIG hyd.

- (2) **MATERIAL SPECIFICATION:-**

- i. ASTM A-105, A-350 LF2, A-106 (Carbon Steel)
- ii. ASTM A-182 (F-304, F-304L, F-316, F-316L, F-304H, F-316H, F-317L, F-321, F-11, F-22, F-91) (Stainless Steel & Low Alloy Steel)

- (3) **FINISHING:-**

- i. Carbon Steel - Galvanized or Black.
- ii. Low Alloy Steel - Black
- iii. Stainless Steel - Pickled

- (4) **IS:1239 (Part 2) 2011 / BS EN 10241 - 2000** For Forged Steel Pipe Fittings with Threaded End Connections.

We use the finest quality of steel specially ment for forged Steel Pipe Fittings, This Steel has minimum Tensile Strength of 320N/mm². The Threads of these fittings comply with requirements of IS-554:1985.

We also manufacture fittings with **NPT** Thread Connections. These Fittings are Thoroughly Checked with Calibrated Thread Gauges and are Leak tested at **1000 PSIG hyd.**

'VS' Brand of Forged Steel Pipe Fittings are Synonymous to Quality & Endurance. The Brand has no Complaints for Leakage on Fitment or in Operation when fitted on Fluid systems. Working within a Recommended Pressure Range.

All **'VS'** Fittings have a Black finish and these are Pre-Treated to prevent Rust formation Prior to packaging. These fittings can also be Hot Galvanized as per IS : 4736 - 1986

IBR Certificate

GOVT. OF PUNJAB
Department of Industries & Commerce, Punjab,
Office of the Director of Boilers, Punjab, Jalandhar
Tel: 0181-2686982, Fax: 0181-2686984

Dated: 4-3-2015

No.DOB/PB/JAL/ 653

To **653**

M/s. Vijay Cycle and Steel Industries,
A-8, A-9, Focal Point,
Jalandhar.

Subject: Regarding manufacturing of Forged Steel Pipe Fittings under I.B.R. 1950.

Reference you application dated 15-10-2014 which was received in this office on 27-10-14 on the above noted subject.

You are allowed to manufacture Forged Steel Pipe Fittings as per the requirements of Indian Boiler Regulations, 1950 with the following conditions.

- 1) The drawings should be got approved in advance from this office.
- 2) Manufacturing should be done in accordance with provisions of I.B.R. 1950.
- 3) Proper record of manufacturing and inspections to be maintained in accordance with I.B.R. 1950.
- 4) Proper lab equipment should be maintained to facilitate inspection of product by representative of this office.
- 5) Finished goods be despatched only after getting the consignment inspected by this office.
- 6) If at any stage the workmanship is found defective this office reserves the right to revoke the permission granted in your favour.
- 7) Any violations of provisions of act/regulations may lead to disqualification.

Director of Boilers, Punjab,
Jalandhar.
JALANDHAR

**Forged Steel
High Pressure Socket Weld
Pipe Fittings 3000 Lbs.**



THE NO. 1 FORGED
STEEL PIPE FITTINGS





Socket Weld Elbow 90°

THE NO.1 FORGED STEEL PIPE FITTINGS

▼ Art No. VS-3001

FORGED 3000 Lbs BLACK

Manufacturing 'VS' pipe fittings for big chemical and pharmaceutical industries asks for perfection. Our socket welding elbows live up to the required standards of perfection in quality and endurance.



a structure for Application - Reaction Tank

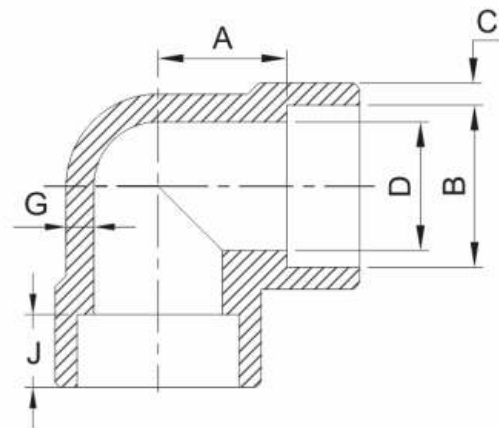

Class Designation : 3000 Lbs DIMENSIONS AS PER ASME B 16.11 - 2011 / IS : 4712 : 2011 (CLASS 20)

NOMINAL SIZE		SOCKET BORE DIA		BORE DIA OF FITTING		SOCKET WALL THICKNESS	MIN. DEPTH OF SOCKET	CENTER TO BOTTOM OF SOCKET		BODY WALL THICKNESS
		B		D		C	J	A		G
Inch	MM	Min.	Max.	Min.	Max.	Min.		Min.	Max.	Min.
1/8"	6	10.8	11.2	6.1	7.6	3.18	10.5	11	12	2.41
1/4"	8	14.2	14.6	8.5	10	3.78	10.5	11	12	3.02
3/8"	10	17.6	18	11.8	13.3	4.01	10.5	13.5	15	3.2
1/2"	15	21.8	22.2	15	16.6	4.67	10.5	15.5	17	3.73
3/4"	20	27.2	27.6	20.2	21.7	4.9	13.5	19	20.5	3.91
1"	25	33.9	34.3	25.9	27.4	5.69	13.5	22.5	24	4.55
1¼"	32	42.7	43.1	34.3	35.8	6.07	13.5	27	29	4.85
1½"	40	48.8	49.2	40.1	41.6	6.35	13.5	32	34	5.08
2"	50	61.2	61.7	51.7	53.3	6.93	17	38	40	5.54
2½"	65	73.9	74.4	61.2	64.2	8.76	18	42	43.5	7.01
3"	80	89.8	90.3	76.4	79.4	9.52	18	57	59.5	7.62

ALL DIMENSIONS IN MM

Reducing Socket Weld Elbow 90°



FORGED 3000 Lbs BLACK

Art No. VS-3002 ▼

THE NO.1 FORGED STEEL PIPE FITTINGS



The aviation asks for nothing less than perfection & we provide perfection in every piece branded 'VS'

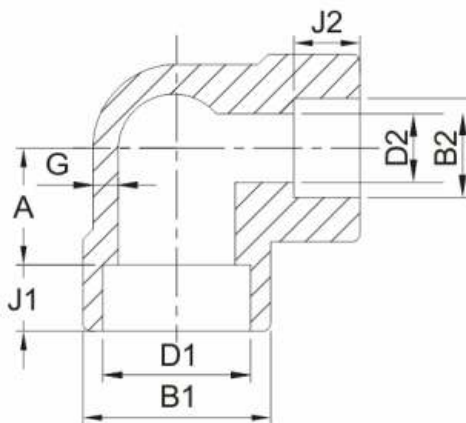

a structure for Application - Aviation Industry

Class Designation : 3000 Lbs DIMENSIONS "VS" REDUCING SOCKET WELD ELBOW

NOMINAL SIZE		CENTRE TO BOTTOM OF SOCKET A		SOCKET BORE DIAMETER(B)				SOCKET WALL THICKNESS C	BORE DIAMETER OF FITTING				BODY WALL THICKNESS G	DEPTH OF SOCKET	
Inch	MM	Min.	Max.	(B1)		(B2)			(D1)		(D2)			(J1)	(J2)
1/4"x1/8"	8x6	10	12	14.2	14.6	10.8	11.2	3.78	8.5	10	6.1	7.6	3.02	6.1	10.5
3/8"x1/4"	10x8	12	15	17.6	18	14.2	14.6	4.01	11.8	13.3	8.5	10	3.2	8.5	10.5
1/2"x3/8"	15x10	14	17	21.8	22	17.6	18	4.67	15	16.6	11.8	13.3	3.73	11.8	10.5
3/4"x1/2"	20x15	18	21	27.2	27.6	21.8	22.2	4.9	20.2	21.7	15	16.6	3.91	15	10.5
1"x1/2"	25x15	20	24	33.9	34.3	21.8	22.2	5.69	25.9	27.4	15	16.6	4.55	15	10.5
1"x3/4"	25x20	20	24	33.9	34.3	27.2	27.6	5.69	25.9	27.4	20.2	21.7	4.55	20.2	13.5
1 1/4"x3/4"	32x20	25	29	42.7	43.1	27.2	27.6	6.07	34.3	35.8	20.2	21.7	4.85	20.2	13.5
1 1/4"x1"	32x25	25	29	42.7	43.1	33.9	34.3	6.07	34.3	35.8	25.9	27.4	4.85	25.9	13.5
1 1/2"x1"	40x25	30	34	48.8	49.2	33.9	34.3	6.35	40.1	41.6	25.9	27.4	5.08	25.9	13.5
1 1/2"x1 1/4"	40x32	30	34	48.8	49.2	42.7	43.1	6.35	40.1	41.6	34.3	35.8	5.08	34.3	13.5
2"x1 1/4"	50x32	35	40	61.2	61.7	42.7	43.1	6.93	51.7	53.3	34.3	35.8	5.54	34.3	13.5
2"x1 1/2"	50x40	36	40	61.2	61.7	48.8	49.2	6.93	51.7	53.3	40.1	41.6	5.54	40.1	13.5
2 1/2"x2"	65x40	38.5	43.5	73.2	74.4	61.2	61.7	8.76	61.2	64.2	51.7	53.3	7.01	51.7	16
2 1/2"x1 1/2"	65x40	38.5	43.5	73.2	74.4	48.8	49.2	8.76	61.2	64.2	40.1	41.6	7.01	40.1	13.5
3"x2 1/2"	80x65	54.5	59.5	89.8	90.3	73.9	74.4	9.52	76.4	79.4	61.2	64.2	7.62	61.2	16
3"x2"	80x50	54.5	59.5	89.8	90.3	61.2	61.7	9.52	76.4	79.4	51.7	53.3	7.62	51.7	16

ALL DIMENSIONS IN MM



Socket Weld Tee

THE NO.1 FORGED STEEL PIPE FITTINGS

▼ Art No. VS-3003

FORGED 3000 Lbs BLACK

These 'VS' fittings are used in steam run applications like steam turbines and boilers because of their strength to curtail high pressures.



a structure for Application - Steam Turbine

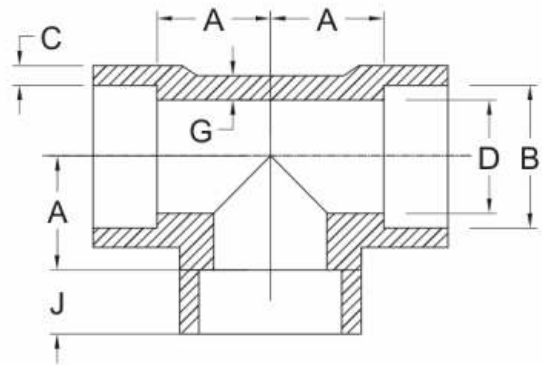

Class Designation : 3000 Lbs DIMENSIONS AS PER ASME B 16.11 - 2011 / IS : 4712 : 2011 (CLASS 20)

NOMINAL SIZE		SOCKET BORE DIA		BORE DIA OF FITTING		SOCKET WALL THICKNESS	MIN. DEPTH OF SOCKET	CENTER TO BOTTOM OF SOCKET		BODY WALL THICKNESS
		B		D		C	J	A		G
Inch	MM	Min.	Max.	Min.	Max.	Min.		Min.	Max.	Min.
1/8"	6	10.8	11.2	6.1	7.6	3.18	10.5	11	12	2.41
1/4"	8	14.2	14.6	8.5	10	3.78	10.5	11	12	3.02
3/8"	10	17.6	18	11.8	13.3	4.01	10.5	13.5	15	3.2
1/2"	15	21.8	22.2	15	16.6	4.67	10.5	15.5	17	3.73
3/4"	20	27.2	27.6	20.2	21.7	4.9	13.5	19	20.5	3.91
1"	25	33.9	34.3	25.9	27.4	5.69	13.5	22.5	24	4.55
1¼"	32	42.7	43.1	34.3	35.8	6.07	13.5	27	29	4.85
1½"	40	48.8	49.2	40.1	41.6	6.35	13.5	32	34	5.08
2"	50	61.2	61.7	51.7	53.3	6.93	17	38	40	5.54
2½"	65	73.9	74.4	61.2	64.2	8.76	18	42	43.5	7.01
3"	80	89.8	90.3	76.4	79.4	9.52	18	57	59.5	7.62

ALL DIMENSIONS IN MM

Reducing Socket Weld Tee



FORGED 3000 Lbs BLACK

Art No. VS-3004 ▼

THE NO.1 FORGED STEEL PIPE FITTINGS



These 'VS' fittings are synonymous to precision & they prove it in every field of application.

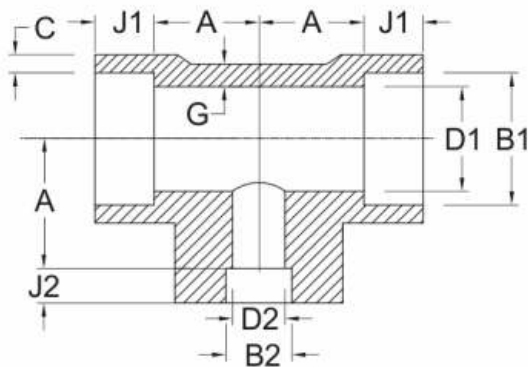

a structure for Application - Ash Handling Plant

Class Designation : 3000 Lbs DIMENSIONS "VS" REDUCING SOCKET WELD TEE

NOMINAL SIZE		CENTRE TO BOTTOM OF SOCKET A		SOCKET BORE DIAMETER(B)				SOCKET WALL THICKNESS C	BORE DIAMETER OF FITTING				BODY WALL THICKNESS G	DEPTH OF SOCKET	
Inch	MM	Min.	Max.	(B1)		(B2)		Min.	(D1)		(D2)		Min.	(J1)	(J2)
				Min.	Max.	Min.	Max.	Min.	Min.	Max.	Min.	Max.	Min.	Min.	Min.
1/4"x1/8"	8x6	10	12	14.2	14.6	10.8	11.2	3.78	8.5	10	6.1	7.6	3.02	10.5	10.5
3/8"x1/4"	10x8	12	15	17.6	18	14.2	14.6	4.01	11.8	13.3	8.5	10	3.2	10.5	10.5
1/2"x3/8"	15x10	14	17	21.8	22	17.6	18	4.67	15	16.6	11.8	13.3	3.73	10.5	10.5
3/4"x1/2"	20x15	18	21	27.2	27.6	21.8	22.2	4.9	20.2	21.7	15	16.6	3.91	13.5	10.5
1"x1/2"	25x15	20	24	33.9	34.3	21.8	22.2	5.69	25.9	27.4	15	16.6	4.55	13.5	10.5
1"x3/4"	25x20	20	24	33.9	34.3	27.2	27.6	5.69	25.9	27.4	20.2	21.7	4.55	13.5	13.5
1 1/4"x3/4"	32x20	25	29	42.7	43.1	27.2	27.6	6.07	34.3	35.8	20.2	21.7	4.85	13.5	13.5
1 1/4"x1"	32x25	25	29	42.7	43.1	33.9	34.3	6.07	34.3	35.8	25.9	27.4	4.85	13.5	13.5
1 1/2"x1"	40x25	30	34	48.8	49.2	33.9	34.3	6.35	40.1	41.6	25.9	27.4	5.08	13.5	13.5
1 1/2"x1 1/4"	40x32	30	34	48.8	49.2	42.7	43.1	6.35	40.1	41.6	34.3	35.8	5.08	13.5	13.5
2"x1 1/4"	50x32	35	40	61.2	61.7	42.7	43.1	6.93	51.7	53.3	34.3	35.8	5.54	16	13.5
2"x1 1/2"	50x40	36	40	61.2	61.7	48.8	49.2	6.93	51.7	53.3	40.1	41.6	5.54	16	13.5
2 1/2"x2"	65x40	38.5	43.5	73.2	74.4	61.2	61.7	8.76	61.2	64.2	51.7	53.3	7.01	16	16
2 1/2"x1 1/2"	65x40	38.5	43.5	73.2	74.4	48.8	49.2	8.76	61.2	64.2	40.1	41.6	7.01	16	13.5
3"x2 1/2"	80x65	54.5	59.5	89.8	90.3	73.9	74.4	9.52	76.4	79.4	61.2	64.2	7.62	16	16
3"x2"	80x50	54.5	59.5	89.8	90.3	61.2	61.7	9.52	76.4	79.4	51.7	53.3	7.62	16	16

ALL DIMENSIONS IN MM



Socket Weld Socket

THE NO.1 FORGED STEEL PIPE FITTINGS

FORGED 3000 Lbs BLACK

Art No. VS-3005

Rigidity is the key word for manufacturing 'VS' fittings for steam hammers. These set the standards of perfection in quality and endurance.



a structure for Application - Steam Hammers

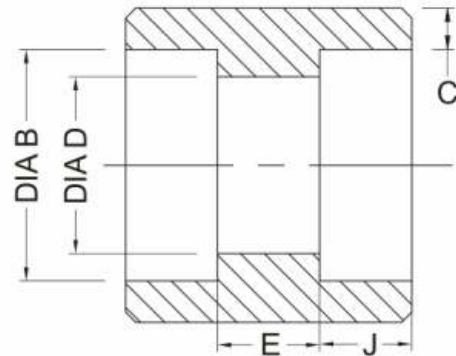

Class Designation : 3000 Lbs DIMENSIONS AS PER ASME B 16.11 - 2011 / IS : 4712 : 2011 (CLASS 20)

NOMINAL SIZE		SOCKET BORE DIA B		BORE DIA OF FITTING D		SOCKET WALL THICKNESS C	MIN. DEPTH OF SOCKET J	LAYING LENGTH E	
Inch	MM	Min.	Max.	Min.	Max.	Min.	Min.	Min.	Max.
1/8"	6	10.8	11.2	6.1	7.6	3.18	10.5	5	8
1/4"	8	14.2	14.6	8.5	10	3.78	10.5	5	8
3/8"	10	17.6	18	11.8	13.3	4.01	10.5	5	9
1/2"	15	21.8	22.2	15	16.6	4.67	10.5	6.5	12.5
3/4"	20	27.2	27.6	20.2	21.7	4.9	13.5	6.5	12.5
1"	25	33.9	34.3	25.9	27.4	5.69	13.5	8.5	16.5
1 1/4"	32	42.7	43.1	34.3	35.8	6.07	13.5	8.5	16.5
1 1/2"	40	48.8	49.2	40.1	41.6	6.35	13.5	8.5	16.5
2"	50	61.2	61.7	51.7	53.3	6.93	17	15	23
2 1/2"	65	73.9	74.4	61.2	64.2	8.76	18	15	23
3"	80	89.8	90.3	76.4	79.4	9.52	18	15	23

ALL DIMENSIONS IN MM

Reducing Socket Weld Socket/Coupling



FORGED 3000 Lbs BLACK

Art No. VS-3006 ▼

THE NO.1 FORGED STEEL PIPE FITTINGS



Manufacturing 'VS' pipe fittings for big industries units asks for perfection. Our fittings live up to those standards.

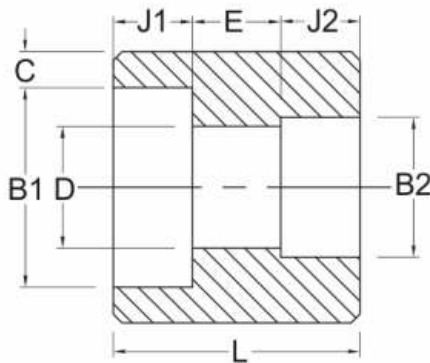

a structure for Application - Desalination Plant

Class Designation : 3000 Lbs DIMENSIONS "VS" REDUCING SOCKET WELD SOCKET/COUPLING

NOMINAL SIZE		SOCKET BORE DIAMETER(B1)				SOCKET WALL THICKNESS C	BORE DIAMETER OF FITTING		DEPTH OF SOCKET		DEPTH OF SOCKET	
		(B1)		(B2)			D		(J1)	(J2)	E	
Inch	MM	Min.	Max.	Min.	Max.	Min.	Min.	Max.	Min.	Max.	Min.	Min.
1/4"x1/8"	8x6	14.2	14.6	10.8	11.2	3.78	6.1	7.6	10.5	10.5	5	8
3/8"x1/4"	10x8	17.6	18	14.2	14.6	4.01	8.5	10	10.5	10.5	5	9
1/2"x3/8"	15x10	21.8	22	17.6	18	4.67	11.8	13.3	10.5	10.5	6	13
3/4"x1/2"	20x15	27.2	27.6	21.8	22.2	4.9	15	16.6	13.5	10.5	6	13
1"x1/2"	25x15	33.9	34.3	21.8	22.2	5.69	15	16.6	13.5	10.5	9	17
1"x3/4"	25x20	33.9	34.3	27.2	27.6	5.69	20.2	21.7	13.5	13.5	9	17
1 1/4"x3/4"	32x20	42.7	43.1	27.2	27.6	6.07	20.2	21.7	13.5	13.5	9	17
1 1/4"x1"	32x25	42.7	43.1	33.9	34.3	6.07	25.9	27.4	13.5	13.5	9	17
1 1/2"x1"	40x25	48.8	49.2	33.9	34.3	6.35	25.9	27.4	13.5	13.5	9	17
1 1/2"x1 1/4"	40x32	48.8	49.2	42.7	43.1	6.35	34.3	35.8	13.5	13.5	9	17
2"x1 1/4"	50x32	61.2	61.7	42.7	43.1	6.93	34.3	35.8	16	13.5	15	23
2"x1 1/2"	50x40	61.2	61.7	48.8	49.2	6.93	40.1	41.6	16	13.5	15	23
2 1/2"x2"	65x40	73.2	74.4	61.2	61.7	8.76	51.7	53.3	16	16	15	23
2 1/2"x1 1/2"	65x40	73.2	74.4	48.8	49.2	8.76	40.1	41.6	16	13.5	15	23
3"x2 1/2"	80x65	89.8	90.3	73.9	74.4	9.52	61.2	64.2	16	16	15	23
3"x2"	80x50	89.8	90.3	61.2	61.7	9.52	51.7	53.3	16	16	15	23

ALL DIMENSIONS IN MM



Socket Weld Cross

THE NO.1 FORGED STEEL PIPE FITTINGS

▼ Art No. VS-3007

FORGED 3000 Lbs BLACK

Ship building industries all over India rely on 'VS' fittings for pipe lines layout in ship building applications.



a structure for Application - Boilers

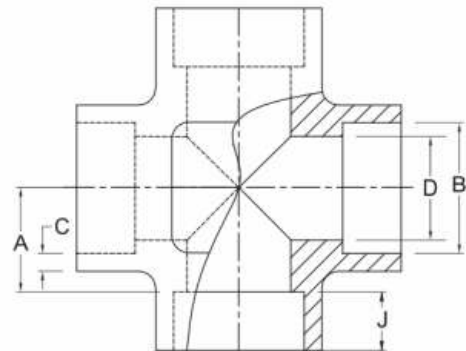

Class Designation : 3000 Lbs DIMENSIONS AS PER ASME B 16.11 - 2011 / IS : 4712 : 2011 (CLASS 20)

NOMINAL SIZE		SOCKET BORE DIA B		BORE DIA OF FITTING D		SOCKET WALL THICKNESS C	Min. DEPTH OF SOCKET J	CENTRE TO BOTTOM OF SOCKET A		BODY WALL THICKNESS G
Inch	MM	Min.	Max.	Min.	Max.	Min.	Min.	Min.	Max.	Min.
1/8"	6	10.8	11.2	6.1	7.6	3.18	10.5	11	12	2.41
1/4"	8	14.2	14.6	8.5	10	3.78	10.5	11	12	3.02
3/8"	10	17.6	18	11.8	13.3	4.01	10.5	13.5	15	3.2
1/2"	15	21.8	22.2	15	16.6	4.67	10.5	15.5	17	3.73
3/4"	20	27.2	27.6	20.2	21.7	4.90	13.5	19	20.5	3.91
1"	25	33.9	34.3	25.9	27.4	5.69	13.5	22.5	24	4.55
1¼"	32	42.7	43.1	34.3	35.8	6.07	13.5	27	29	4.85
1½"	40	48.8	49.2	40.1	41.6	6.35	13.5	32	34	5.08
2"	50	61.2	61.7	51.7	53.3	6.93	17	38	40	5.54
2½"	65	73.9	74.4	61.2	64.2	8.76	18	42	43.5	7.01
3"	80	89.8	90.3	76.4	79.4	9.52	18	57	59.5	7.62

ALL DIMENSIONS IN MM



Socket Weld Elbow 45°

FORGED 3000 Lbs BLACK

Art No. VS-3008 ▼

THE NO.1 FORGED STEEL PIPE FITTINGS



'VS' fittings are being used in textile Industries also. Our socket weld elbow is a versatile component on almost every type of pipeline for plugging of fluid flow.

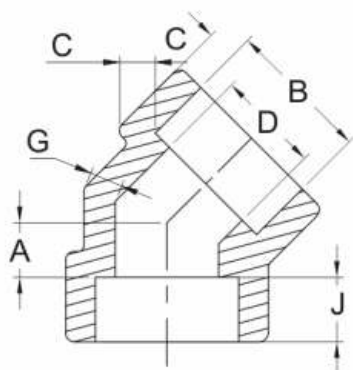

a structure for Application - Refineries

Class Designation : 3000 Lbs DIMENSIONS AS PER ASME B 16.11 - 2011 / IS : 4712 : 2011 (CLASS 20)

NOMINAL SIZE		SOCKET BORE DIA		BORE DIA OF FITTING		SOCKET WALL THICKNESS	MIN. DEPTH OF SOCKET	CENTER TO BOTTOM OF SOCKET		BODY WALL THICKNESS
		B		D		C	J	A		G
Inch	MM	Min.	Max.	Min.	Max.	Min.	Min.	Min.	Max.	Min.
1/8"	6	10.8	11.2	6.1	7.6	3.18	10.5	8.0	9.0	2.41
1/4"	8	14.2	14.6	8.5	10.0	3.78	10.5	8.0	9.0	3.02
3/8"	10	17.6	18.0	11.8	13.3	4.01	10.5	8.0	9.5	3.2
1/2"	15	21.8	22.2	15	16.6	4.67	10.5	11.0	12.5	3.73
3/4"	20	27.2	27.6	20.2	21.7	4.9	13.5	13.0	14.5	3.91
1"	25	33.9	34.3	25.9	27.4	5.69	13.5	14.0	16.0	4.55
1¼"	32	42.7	43.1	34.3	35.8	6.07	13.5	17.5	19.5	4.85
1½"	40	48.8	49.2	40.1	41.6	6.35	13.5	20.5	22.5	5.08
2"	50	61.2	61.7	51.7	53.3	6.93	17	25.5	27.5	5.54
2½"	65	73.9	74.4	61.2	64.2	8.76	18	28.5	31.0	7.01
3"	80	89.8	90.3	76.4	79.4	9.52	18	32.0	34.5	7.62

ALL DIMENSIONS IN MM



Socket Weld Union

THE NO.1 FORGED STEEL PIPE FITTINGS

▼ Art No. VS-3009

FORGED 3000 Lbs BLACK

'VS' fittings are being used in textile Industries also. Our socket weld union is a versatile component on almost every type of pipeline for plugging of fluid flow.



a structure for Application - Shipping

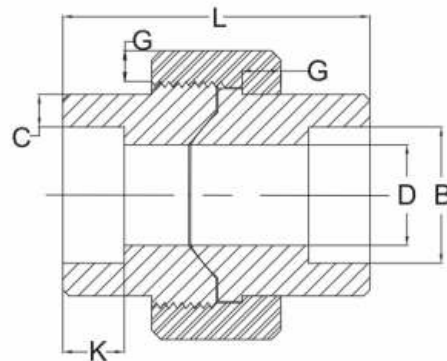

Class Designation : 3000 Lbs DIMENSIONS AS PER MSS-SP-83-2006								
NOMINAL SIZE	SOCKET BORE DIA B		SOCKET WALL THICKNESS C	WATER WAY BORE D		NUT G	DEPTH OF SOCKET K	LENGTH ASSEM. L
	Min.	Max.		Min.	Max.			
1/4"	14.10	14.61	3.30	8.48	10.01	3.18	9.7	45
3/8"	17.53	18.03	3.51	11.76	13.28	3.43	9.7	50
1/2"	21.72	22.23	4.09	15.04	16.56	3.68	9.7	50
3/4"	27.05	27.56	4.27	20.17	21.69	4.06	12.7	60
1"	33.78	34.29	4.98	25.88	27.41	4.45	12.7	65
1 1/4"	42.55	43.05	5.28	34.29	35.81	5.21	12.7	75
1 1/2"	48.64	49.15	5.54	40.13	41.66	4.59	12.7	80
2"	61.11	61.62	6.05	51.74	63.26	6.35	15.7	90
2 1/2"	73.81	74.45	7.67	61.19	64.24	7.11	15.7	103

ALL DIMENSIONS IN MM

**Forged Steel
High Pressure Socket Weld
Pipe Fittings 6000 Lbs.**



THE NO.1 FORGED
STEEL PIPE FITTINGS





Socket Weld Elbow

THE NO.1 FORGED STEEL PIPE FITTINGS

▼ Art No. VS-6001

FORGED 6000 Lbs BLACK

'VS' fittings are being used in textile Industries also. Our socket weld elbow is a versatile component on almost every type of pipeline for plugging of fluid flow.



a structure for Application - Refineries

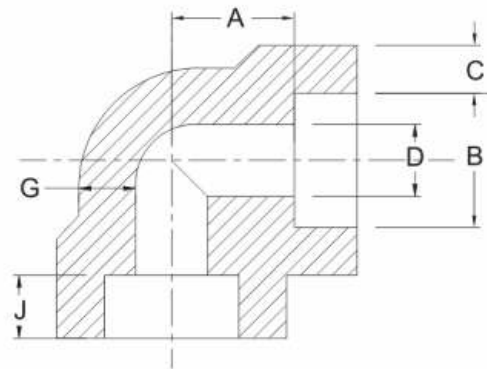

Class Designation : 6000 Lbs DIMENSIONS AS PER ASME B 16.11 - 2011 / IS : 4712 : 2011 (CLASS 40)

NOMINAL SIZE		SOCKET BORE DIA		BORE DIA OF FITTING		SOCKET WALL THICKNESS	MIN. DEPTH OF SOCKET	CENTER TO BOTTOM OF SOCKET		BODY WALL THICKNESS
		B		D		C	J	A		G
Inch	MM	Min.	Max.	Min.	Max.	Min.	Min.	Min.	Max.	Min.
1/8"	6	10.8	11.2	3.2	4.8	3.96	10.5	11.0	12.0	3.15
1/4"	8	14.2	14.6	5.6	7.1	4.6	10.5	13.5	15.0	3.68
3/8"	10	17.6	18.0	8.4	9.9	5.03	10.5	15.5	17.0	4.01
1/2"	15	21.8	22.2	11.0	12.5	5.97	10.5	19.0	20.5	4.78
3/4"	20	27.2	27.6	14.8	16.3	6.96	13.5	22.5	24.5	5.56
1"	25	33.9	34.3	19.9	21.5	7.92	13.5	27.0	29.0	6.35
1 1/4"	32	42.7	43.1	28.7	30.2	7.92	13.5	32.0	34.0	6.35
1 1/2"	40	48.8	49.2	33.2	34.7	8.92	13.5	38.0	40.0	7.14
2"	50	61.2	61.7	42.1	43.6	10.92	17.0	41.0	43.5	8.74
2 1/2"	65	73.9	74.4				18.0			

ALL DIMENSIONS IN MM



Socket Weld Tee

FORGED 6000 Lbs BLACK

Art No. VS-6002 ▼

THE NO.1 FORGED STEEL PIPE FITTINGS



'VS' fittings are being used in textile Industries also. Our socket weld tee is a versatile component on almost every type of pipeline for plugging of fluid flow.

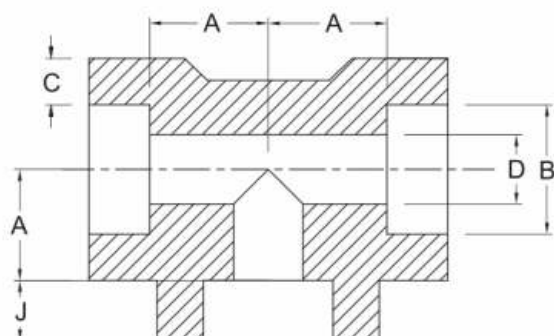

a structure for Application - Aviation Industry

Class Designation : 6000 Lbs DIMENSIONS AS PER ASME B 16.11 - 2011 / IS : 4712 : 2011 (CLASS 40)

NOMINAL SIZE		SOCKET BORE DIA B		BORE DIA OF FITTING D		SOCKET WALL THICKNESS C	MIN. DEPTH OF SOCKET J	CENTER TO BOTTOM OF SOCKET A		BODY WALL THICKNESS G
Inch	MM	Min.	Max.	Min.	Max.	Min.	Min.	Min.	Max.	Min.
1/8"	6	10.8	11.2	3.2	4.8	3.96	10.5	11.0	12.0	3.15
1/4"	8	14.2	14.6	5.6	7.1	4.6	10.5	13.5	15.0	3.68
3/8"	10	17.6	18.0	8.4	9.9	5.03	10.5	15.5	17.0	4.01
1/2"	15	21.8	22.2	11.0	12.5	5.97	10.5	19.0	20.5	4.78
3/4"	20	27.2	27.6	14.8	16.3	6.96	13.5	22.5	24.5	5.56
1"	25	33.9	34.3	19.9	21.5	7.92	13.5	27.0	29.0	6.35
1 1/4"	32	42.7	43.1	28.7	30.2	7.92	13.5	32.0	34.0	6.35
1 1/2"	40	48.8	49.2	33.2	34.7	8.92	13.5	38.0	40.0	7.14
2"	50	61.2	61.7	42.1	43.6	10.92	17.0	41.0	43.5	8.74
2 1/2"	65	73.9	74.4				18.0			

ALL DIMENSIONS IN MM



Socket Weld Cross

THE NO.1 FORGED STEEL PIPE FITTINGS

FORGED 6000 Lbs BLACK

▼ Art No. VS-6003

Ship building industries all over India rely on 'VS' fittings for pipe lines layout in ship building applications.



a structure for Application - Ash Handling Plant

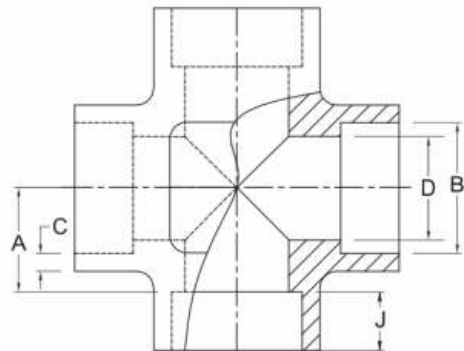

Class Designation : 6000 Lbs DIMENSIONS AS PER ASME B 16.11 - 2011 / IS : 4712 : 2011 (CLASS 40)

NOMINAL SIZE		SOCKET BORE DIA		BORE DIA OF FITTING		SOCKET WALL THICKNESS	Min. DEPTH OF SOCKET	CENTRE TO BOTTOM OF SOCKET		BODY WALL THICKNESS
		B		D		C	J	A		G
Inch	MM	Min.	Max.	Min.	Max.	Min.	Min.	Min.	Max.	Min.
1/8"	6	10.8	11.2	3.2	4.8	3.96	10.5	11.0	12.0	3.15
1/4"	8	14.2	14.6	5.6	7.1	4.6	10.5	13.5	15.0	3.68
3/8"	10	17.6	18	8.4	9.9	5.03	10.5	15.5	17.0	4.01
1/2"	15	21.8	22.2	11	12.5	5.97	10.5	19.0	20.5	4.78
3/4"	20	27.2	27.6	14.8	16.3	6.96	13.5	22.5	24.5	5.56
1"	25	33.9	34.3	19.9	21.5	7.92	13.5	27.0	29.0	6.35
1¼"	32	42.7	43.1	28.7	30.2	7.92	13.5	32.0	34.0	6.35
1½"	40	48.8	49.2	33.2	34.7	8.92	13.5	38.0	40.0	7.14
2"	50	61.2	61.7	42.1	43.6	10.92	17.0	41.0	43.5	8.74
2½"	65	73.9	74.4				18.0			

ALL DIMENSIONS IN MM



Socket Weld Elbow 45°

FORGED 6000 Lbs BLACK

Art No. VS-6004 ▼

THE NO.1 FORGED STEEL PIPE FITTINGS



'VS' fittings are being used in textile Industries also. Our socket weld elbow is a versatile component on almost every type of pipeline for plugging of fluid flow.

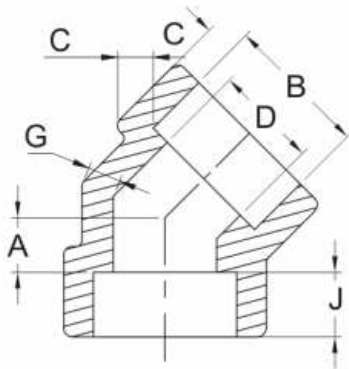

a structure for Application - Steam Turbine

Class Designation : 6000 Lbs DIMENSIONS AS PER ASME B 16.11 - 2011 / IS : 4712 : 2011 (CLASS 40)

NOMINAL SIZE		SOCKET BORE DIA		BORE DIA OF FITTING		SOCKET WALL THICKNESS	MIN. DEPTH OF SOCKET	CENTER TO BOTTOM OF SOCKET		BODY WALL THICKNESS
		B		D		C	J	A		G
Inch	MM	Min.	Max.	Min.	Max.	Min.	Min.	Min.	Max.	Min.
1/8"	6	10.8	11.2	3.2	4.8	3.96	10.5	7.0	9.0	3.15
1/4"	8	14.2	14.6	5.6	7.1	4.6	10.5	7.0	9.0	3.68
3/8"	10	17.6	18.0	8.4	9.9	5.03	10.5	9.5	12.5	4.01
1/2"	15	21.8	22.2	11.0	12.5	5.97	10.5	11.0	14.0	4.78
3/4"	20	27.2	27.6	14.8	16.3	6.96	13.5	12.5	15.5	5.56
1"	25	33.9	34.3	19.9	21.5	7.92	13.5	15.5	19.5	6.35
1 1/4"	32	42.7	43.1	28.7	30.2	7.92	13.5	18.5	22.5	6.35
1 1/2"	40	48.8	49.2	33.2	34.7	8.92	13.5	23.5	27.5	7.14
2"	50	61.2	61.7	42.1	43.6	10.92	17.0	26.5	30.5	8.74
2 1/2"	65	73.9	74.4				18.0			

ALL DIMENSIONS IN MM



Socket Weld Socket / Coupling

THE NO.1 FORGED STEEL PIPE FITTINGS

▼ Art No. VS-6005

FORGED 6000 Lbs BLACK

'VS' fittings are being used in textile Industries also. Our socket weld socket/coupling is a versatile component on almost every type of pipeline for plugging of fluid flow.



a structure for Application - Refineries

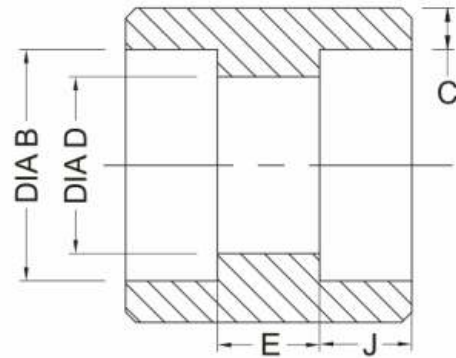

Class Designation : 6000 Lbs DIMENSIONS AS PER ASME B 16.11 - 2011 / IS : 4712 : 2011 (CLASS 40)

NOMINAL SIZE		SOCKET BORE DIA B		BORE DIA OF FITTING D		SOCKET WALL THICKNESS C	MIN. DEPTH OF SOCKET J	LAYING LENGTH E	
Inch	MM	Min.	Max.	Min.	Max.	Min.	Min.	Min.	Max.
1/8"	6	10.8	11.2	3.2	4.8	3.96	10.5	5	8
1/4"	8	14.2	14.6	5.6	7.1	4.6	10.5	5	8
3/8"	10	17.6	18.0	8.4	9.9	4.03	10.5	5	9
1/2"	15	21.8	22.2	11.0	12.5	5.97	10.5	6.5	12.5
3/4"	20	27.2	27.6	14.8	16.3	6.96	13.5	6.5	12.5
1"	25	33.9	34.3	19.9	21.5	7.92	13.5	8.5	16.5
1 1/4"	32	42.7	43.1	28.7	30.2	7.92	13.5	8.5	16.5
1 1/2"	40	48.8	49.2	33.2	34.7	8.92	13.5	8.5	16.5
2"	50	61.2	61.7	42.1	43.6	10.92	17	15	23
2 1/2"	65	73.9	74.4				18	15	24

ALL DIMENSIONS IN MM

**Forged Steel
High Pressure Socket Weld
Pipe Fittings 9000 Lbs.**



THE NO.1 FORGED
STEEL PIPE FITTINGS





Socket Weld Elbow

THE NO.1 FORGED STEEL PIPE FITTINGS

FORGED 9000 Lbs BLACK

▼ Art No. VS-9001

'VS' fittings are being used in textile Industries also. Our socket weld elbow is a versatile component on almost every type of pipeline for plugging of fluid flow.



a structure for Application - Refineries

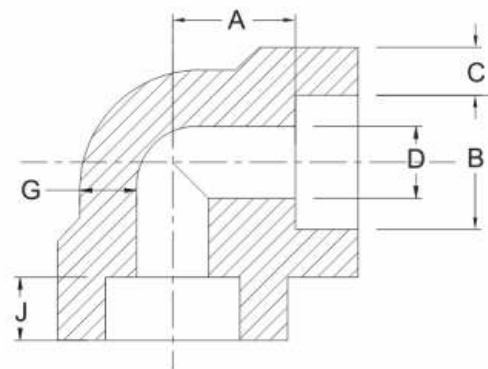

Class Designation : 9000 Lbs DIMENSIONS AS PER ASME B 16.11 - 2011										
NOMINAL SIZE		SOCKET BORE DIA		BORE DIA OF FITTING		SOCKET WALL THICKNESS	MIN. DEPTH OF SOCKET	CENTER TO BOTTOM OF SOCKET		BODY WALL THICKNESS
		B		D		C	J	A		G
Inch	MM	Min.	Max.	Min.	Max.	Min.	Min.	Min.	Max.	Min.
1/2"	15	21.8	22.2	5.6	7.2	9.35	10.5	25.5	27.0	7.47
3/4"	20	27.2	27.6	10.3	11.8	9.78	13.5	28.5	30.0	7.82
1"	25	33.9	34.3	14.4	16.0	11.38	13.5	32.0	34.0	9.09
1 1/4"	32	42.7	43.1	22.0	23.5	12.14	13.5	35.0	37.0	9.70
1 1/2"	40	48.8	49.2	27.2	28.7	12.7	13.5	38.0	40.0	10.15
2"	50	61.2	61.7	37.4	38.9	13.84	17.0	54.0	56.0	11.07

ALL DIMENSIONS IN MM



Socket Weld Tee

FORGED 9000 Lbs BLACK

Art No. VS-9002 ▼

THE NO.1 FORGED STEEL PIPE FITTINGS



'VS' fittings are being used in textile Industries also. Our socket weld tee is a versatile component on almost every type of pipeline for plugging of fluid flow.

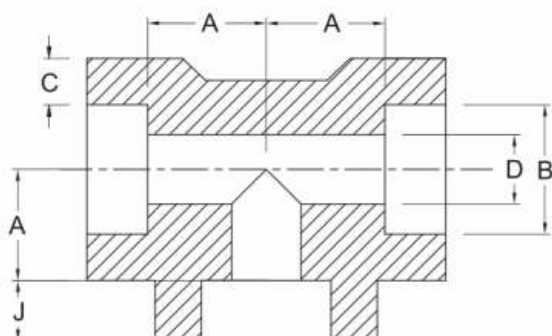

a structure for Application - Refineries

Class Designation : 9000 Lbs DIMENSIONS AS PER ASME B 16.11 - 2011

NOMINAL SIZE		SOCKET BORE DIA B		BORE DIA OF FITTING D		SOCKET WALL THICKNESS C	MIN. DEPTH OF SOCKET J	CENTER TO BOTTOM OF SOCKET A		BODY WALL THICKNESS G
Inch	MM	Min.	Max.	Min.	Max.	Min.	Min.	Min.	Max.	Min.
1/2"	15	21.8	22.2	5.6	7.2	9.35	10.5	25.5	27.0	7.47
3/4"	20	27.2	27.6	10.3	11.8	9.78	13.5	28.5	30.0	7.82
1"	25	33.9	34.3	14.4	16.0	11.38	13.5	32.0	34.0	9.09
1 1/4"	32	42.7	43.1	22.0	23.5	12.14	13.5	35.0	37.0	9.70
1 1/2"	40	48.8	49.2	27.2	28.7	12.7	13.5	38.0	40.0	10.15
2"	50	61.2	61.7	37.4	38.9	13.84	17.0	54.0	56.0	11.07

ALL DIMENSIONS IN MM



Socket Weld Cross

THE NO.1 FORGED STEEL PIPE FITTINGS

▼ Art No. VS-9003

FORGED 9000 Lbs BLACK

Ship building industries all over India rely on 'VS' fittings for pipe lines layout in ship building applications.



a structure for Application - Refineries

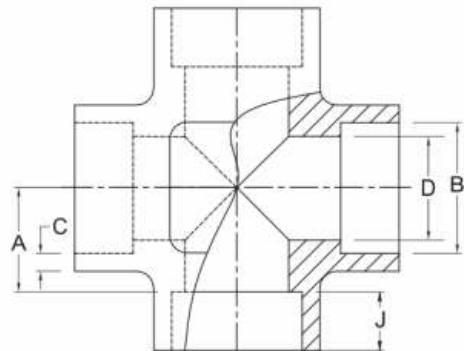

Class Designation : 9000 Lbs DIMENSIONS AS PER ASME B 16.11 - 2011										
NOMINAL SIZE		SOCKET BORE DIA		BORE DIA OF FITTING		SOCKET WALL THICKNESS	MIN. DEPTH OF SOCKET	CENTER TO BOTTOM OF SOCKET		BODY WALL THICKNESS
		B		D		C	J	A		G
Inch	MM	Min.	Max.	Min.	Max.	Min.	Min.	Min.	Max.	Min.
1/2"	15	21.8	22.2	5.6	7.2	9.35	10.5	25.5	27.0	7.47
3/4"	20	27.2	27.6	10.3	11.8	9.78	13.5	28.5	30.0	7.82
1"	25	33.9	34.3	14.4	16.0	11.38	13.5	32.0	34.0	9.09
1 1/4"	32	42.7	43.1	22.0	23.5	12.14	13.5	35.0	37.0	9.70
1 1/2"	40	48.8	49.2	27.2	28.7	12.7	13.5	38.0	40.0	10.15
2"	50	61.2	61.7	37.4	38.9	13.84	17.0	54.0	56.0	11.07

ALL DIMENSIONS IN MM



Socket Weld Elbow 45°

FORGED 9000 Lbs BLACK

Art No. VS-9004 ▼

THE NO.1 FORGED STEEL PIPE FITTINGS



'VS' fittings are being used in textile Industries also. Our socket weld elbow is a versatile component on almost every type of pipeline for plugging of fluid flow.

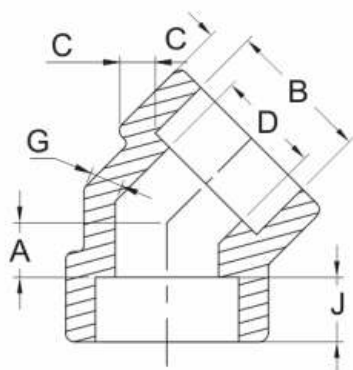

a structure for Application - Petrochemicals

Class Designation : 9000 Lbs DIMENSIONS AS PER ASME B 16.11 - 2011

NOMINAL SIZE		SOCKET BORE DIA		BORE DIA OF FITTING		SOCKET WALL THICKNESS	MIN. DEPTH OF SOCKET	CENTER TO BOTTOM OF SOCKET		BODY WALL THICKNESS
		B		D		C	J	A		G
Inch	MM	Min.	Max.	Min.	Max.	Min.	Min.	Min.	Max.	Min.
1/2"	15	21.8	22.2	5.6	7.2	9.35	10.5	14.0	17.0	7.47
3/4"	20	27.2	27.6	10.3	11.8	9.78	13.5	17.5	20.5	7.82
1"	25	33.9	34.3	14.4	16.0	11.38	13.5	18.5	22.5	9.09
1 1/4"	32	42.7	43.1	22.0	23.5	12.14	13.5	20.5	24.5	9.70
1 1/2"	40	48.8	49.2	27.2	28.7	12.7	13.5	23.5	27.5	10.15
2"	50	61.2	61.7	37.4	38.9	13.84	17.0	26.5	30.5	11.07

ALL DIMENSIONS IN MM



Socket Weld Socket / Coupling

THE NO.1 FORGED STEEL PIPE FITTINGS

▼ Art No. VS-9005

FORGED 9000 Lbs BLACK

Rigidity is the key word for manufacturing 'VS' fittings for steam hammers. These set the standards of perfection in quality and endurance.



a structure for Application - Reaction Tank

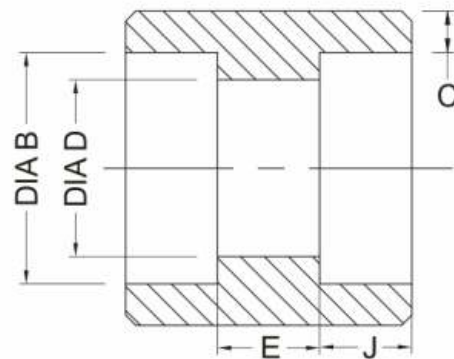

Class Designation : 9000 Lbs DIMENSIONS AS PER ASME B 16.11 - 2011

NOMINAL SIZE		SOCKET BORE DIA B		BORE DIA OF FITTING D		SOCKET WALL THICKNESS C	MIN. DEPTH OF SOCKET J	LAYING LENGTH E	
Inch	MM	Min.	Max.	Min.	Max.	Min.	Min.	Min.	Max.
1/2"	15	21.8	22.2	5.6	7.2	9.35	10.5	6.5	12.5
3/4"	20	27.2	27.6	10.3	11.8	9.78	13.5	6.5	12.5
1"	25	33.9	34.3	14.4	16.0	11.38	13.5	8.5	16.5
1 1/4"	32	42.7	43.1	22.0	23.5	12.14	13.5	8.5	16.5
1 1/2"	40	48.8	49.2	27.2	28.7	12.7	13.5	8.5	16.5
2"	50	61.2	61.7	37.4	38.9	13.84	17.0	15	23

ALL DIMENSIONS IN MM

**Forged Steel
High Pressure Pipe Fittings
with Threaded End Connection
2000 Lbs, 3000 Lbs, 6000 Lbs.**



**THE NO.1 FORGED
STEEL PIPE FITTINGS**





Threaded Elbow 90°

THE NO.1 FORGED STEEL PIPE FITTINGS

▼ Art No. VS-2101

■ FORGED 2000 Lbs BLACK

'VS' fittings are being used in textile Industries also. Our threaded elbow is a versatile component on almost every type of pipeline for plugging of fluid flow.



a structure for Application - Steam Turbine

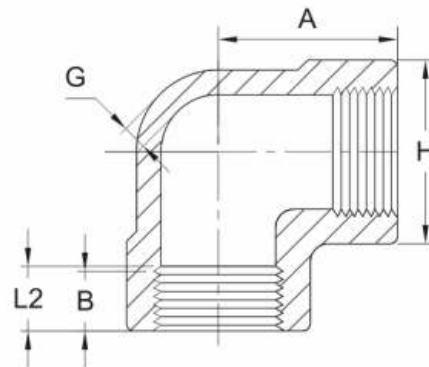

Class Designation : 2000 Lbs STANDARD REFERENCE : ASME B16.11 - 2011

NOMINAL SIZE		CENTER TO END A	OUTSIDE DIA H	Min. WALL THICKNESS G	MIN. LENGTH OF THD	
Inch	MM	Min.	Min.	Min.	B	L2
1/8"	6	21.0	22.0	3.18	6.4	6.7
1/4"	8	21.0	22.0	3.18	8.1	10.2
3/8"	10	25.0	25.0	3.18	9.1	10.4
1/2"	15	28.0	33.0	3.18	10.9	13.6
3/4"	20	33.0	38.0	3.18	12.7	13.9
1"	25	38.0	46.0	3.68	14.7	17.3
1¼"	32	44.0	56.0	3.89	17.0	18.0
1½"	40	51.0	62.0	4.01	17.8	18.4
2"	50	60.0	75.0	4.27	19.0	19.2
2½"	65	76.0	92.0	5.61	23.6	28.9
3"	80	86.0	109	5.99	25.9	30.5

ALL DIMENSIONS IN MM

Material is Available in - NPT, BSPT & BSP Threaded End Connection.



Threaded Tee

FORGED 2000 Lbs BLACK

Art No. VS-2102 ▼

THE NO.1 FORGED STEEL PIPE FITTINGS



'VS' fittings are being used in textile Industries also. Our threaded tee is a versatile component on almost every type of pipeline for plugging of fluid flow.

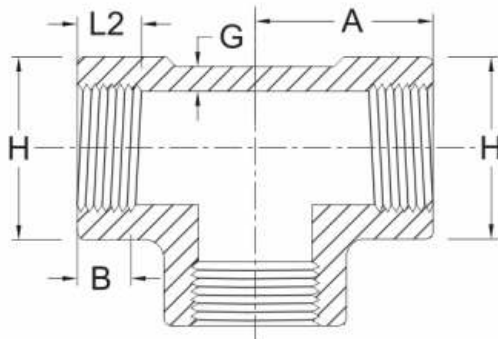

a structure for Application - Steam Hammers

Class Designation : 2000 Lbs STANDARD REFERENCE : ASME B16.11 - 2011

NOMINAL SIZE		CENTER TO END A	OUTSIDE DIA H	Min. WALL THICKNESS G	MIN. LENGTH OF THD	
Inch	MM	Min.	Min.	Min.	B	L2
1/8"	6	21.0	22.0	3.18	6.4	6.7
1/4"	8	21.0	22.0	3.18	8.1	10.2
3/8"	10	25.0	25.0	3.18	9.1	10.4
1/2"	15	28.0	33.0	3.18	10.9	13.6
3/4"	20	33.0	38.0	3.18	12.7	13.9
1"	25	38.0	46.0	3.68	14.7	17.3
1¼"	32	44.0	56.0	3.89	17.0	18.0
1½"	40	51.0	62.0	4.01	17.8	18.4
2"	50	60.0	75.0	4.27	19.0	19.2
2½"	65	76.0	92.0	5.61	23.6	28.9
3"	80	86.0	109	5.99	25.9	30.5

ALL DIMENSIONS IN MM

Material is Available in - NPT, BSPT & BSP Threaded End Connection.



Threaded Cross

THE NO.1 FORGED STEEL PIPE FITTINGS

▼ Art No. VS-2103

■ FORGED 2000 Lbs BLACK

'VS' fittings are being used in textile Industries also. Our cross threaded is a versatile component on almost every type of pipeline for plugging of fluid flow.



a structure for Application - Boilers

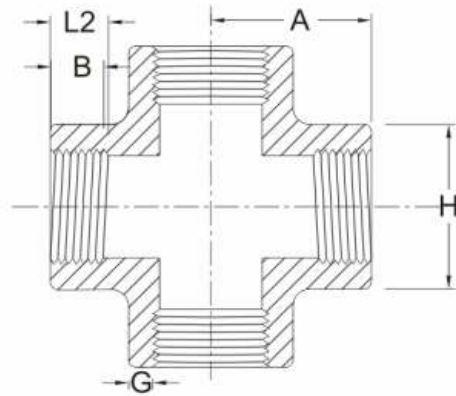

Class Designation : 2000 Lbs STANDARD REFERENCE : ASME B16.11 - 2011

NOMINAL SIZE		CENTER TO END A	OUTSIDE DIA H	Min. WALL THICKNESS G	MIN. LENGTH OF THD	
Inch	MM	Min.	Min.	Min.	B	L2
1/8"	6	21.00	22.00	3.18	6.4	6.7
1/4"	8	21.00	22.00	3.18	8.1	10.2
3/8"	10	25.00	25.00	3.18	9.1	10.4
1/2"	15	28.00	33.00	3.18	10.9	13.6
3/4"	20	33.00	38.00	3.18	12.7	13.9
1"	25	38.00	46.00	3.68	14.7	17.3
1 1/4"	32	44.00	56.00	3.89	17.0	18
1 1/2"	40	51.00	62.00	4.01	17.8	18.4
2"	50	60.00	75.00	4.27	19	19.2
2 1/2"	65	76.00	92.00	5.61	23.6	28.9
3"	80	86.00	109.00	5.99	25.9	30.5

ALL DIMENSIONS IN MM



Threaded Elbow 45°

FORGED 2000 Lbs BLACK

Art No. VS-2104 ▼

THE NO.1 FORGED STEEL PIPE FITTINGS



'VS' fittings are being used in textile Industries also. Our threaded elbow is a versatile component on almost every type of pipeline for plugging of fluid flow.

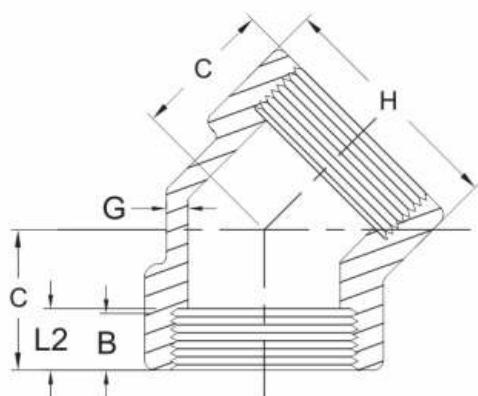

a structure for Application - Refineries

Class Designation : 2000 Lbs

STANDARD REFERENCE : ASME B16.11 - 2011

NOMINAL SIZE		CENTER TO END C	OUTSIDE DIA H	Min. WALL THICKNESS G	MIN. LENGTH OF THD	
Inch	MM	Min.	Min.	Min.	B	L2
1/8"	6	17.00	22.0	3.18	6.4	6.7
1/4"	8	19.00	22.0	3.18	8.1	10.2
3/8"	10	22.00	25.0	3.18	9.1	10.4
1/2"	15	25.00	33.0	3.18	10.9	13.6
3/4"	20	28.00	38.0	3.18	12.7	13.9
1"	25	33.00	46.0	3.68	14.7	17.3
1¼"	32	35.00	56.0	3.89	17.0	18.0
1½"	40	43.00	62.0	4.01	17.8	18.4
2"	50	44.00	75.0	4.27	19.0	19.2
2½"	65	52.00	92.0	5.61	23.6	28.9
3"	80	64.00	109	5.99	25.9	30.5

ALL DIMENSIONS IN MM

Material is Available in - NPT, BSPT & BSP Threaded End Connection.



Threaded Elbow 90°

THE NO.1 FORGED STEEL PIPE FITTINGS

▼ Art No. VS-3101

■ FORGED 3000 Lbs BLACK

'VS' fittings are being used in textile Industries also. Our threaded elbow is a versatile component on almost every type of pipeline for plugging of fluid flow.



a structure for Application - Steam Hammers

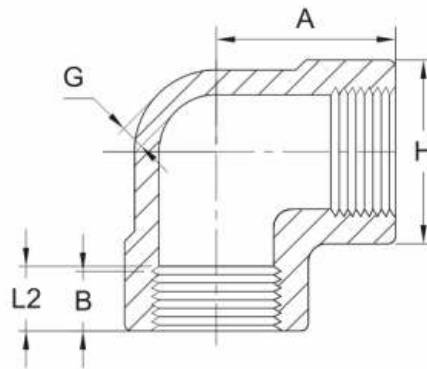

Class Designation : 3000 Lbs STANDARD REFERENCE : ASME B16.11 - 2011

NOMINAL SIZE		CENTER TO END A	OUTSIDE DIA H	Min. WALL THICKNESS G	MIN. LENGTH OF THD	
Inch	MM	Min.	Min.	Min.	B	L2
1/8"	6	21.00	22.00	3.18	6.4	6.7
1/4"	8	25.00	25.00	3.3	8.1	10.2
3/8"	10	28.00	33.00	3.51	9.1	10.4
1/2"	15	33.00	38.00	4.09	10.9	13.6
3/4"	20	38.00	46.00	4.32	12.7	13.9
1"	25	44.00	56.00	4.98	14.7	17.3
1¼"	32	51.00	62.00	5.28	17.0	18.0
1½"	40	60.00	75.00	5.56	17.8	18.4
2"	50	64.00	84.00	7.14	19.0	19.2
2½"	65	83.00	102.00	7.65	23.6	28.9
3"	80	95.00	121.00	8.84	25.9	30.5

ALL DIMENSIONS IN MM



Threaded Tee

FORGED 3000 Lbs BLACK

Art No. VS-3102 ▼

THE NO.1 FORGED STEEL PIPE FITTINGS



'VS' fittings are being used in textile Industries also. Our threaded tee is a versatile component on almost every type of pipeline for plugging of fluid flow.

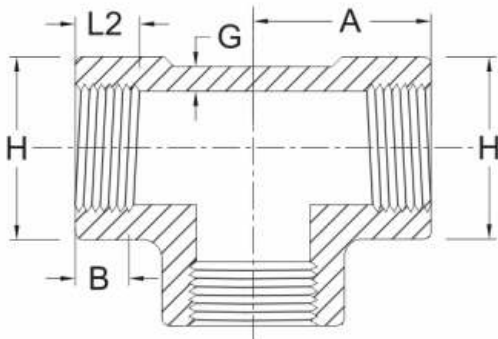

a structure for Application - Desalination Plant

Class Designation : 3000 Lbs STANDARD REFERENCE : ASME B16.11 - 2011

NOMINAL SIZE		CENTER TO END A	OUTSIDE DIA H	Min. WALL THICKNESS G	MIN. LENGTH OF THD	
Inch	MM	Min.	Min.	Min.	B	L2
1/8"	6	21.0	22.0	3.18	6.4	6.7
1/4"	8	25.0	25.0	3.3	8.1	10.2
3/8"	10	28.0	33.0	3.51	9.1	10.4
1/2"	15	33.0	38.0	4.09	10.9	13.6
3/4"	20	38.0	46.0	4.32	12.7	13.9
1"	25	44.0	56.0	4.98	14.7	17.3
1 1/4"	32	51.0	62.0	5.28	17.0	18.0
1 1/2"	40	60.0	75.0	5.56	17.8	18.4
2"	50	64.0	84.0	7.14	19.0	19.2
2 1/2"	65	83.0	102.0	7.65	23.6	28.9
3"	80	95.0	121.0	8.84	25.9	30.5

ALL DIMENSIONS IN MM

Material is Available in - NPT, BSPT & BSP Threaded End Connection.



Threaded Cross

THE NO.1 FORGED STEEL PIPE FITTINGS

▼ Art No. VS-3103

■ FORGED 3000 Lbs BLACK

'VS' fittings are being used in textile Industries also. Our threaded cross is a versatile component on almost every type of pipeline for plugging of fluid flow.



a structure for Application - Refineries

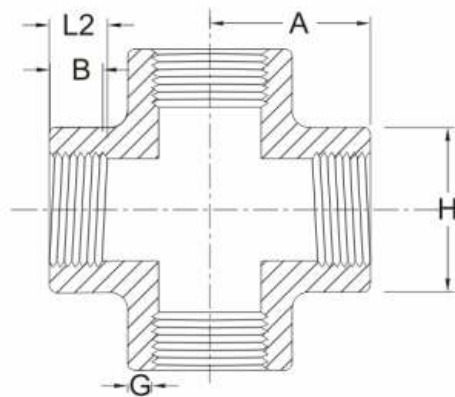

Class Designation : 3000 Lbs **STANDARD REFERENCE : ASME B16.11 - 2011**

NOMINAL SIZE		CENTER TO END A	OUTSIDE DIA H	Min. WALL THICKNESS G	MIN. LENGTH OF THD	
Inch	MM	Min.	Min.	Min.	B	L2
1/8"	6	21.00	22.00	3.18	6.4	6.7
1/4"	8	25.00	25.00	3.30	8.1	10.2
3/8"	10	28.00	33.00	3.51	9.1	10.4
1/2"	15	33.00	38.00	4.09	10.9	13.6
3/4"	20	38.00	46.00	4.32	12.7	13.9
1"	25	44.00	56.00	4.98	14.7	17.3
1¼"	32	51.00	62.00	5.28	17.0	18
1½"	40	60.00	75.00	5.56	17.8	18.4
2"	50	64.00	84.00	7.14	19	19.2
2½"	65	83.00	102.00	7.65	23.6	28.9

ALL DIMENSIONS IN MM



Threaded Elbow 45°

FORGED 3000 Lbs BLACK

Art No. VS-3104 ▼

THE NO.1 FORGED STEEL PIPE FITTINGS



'VS' fittings are being used in textile Industries also. Our threaded elbow is a versatile component on almost every type of pipeline for plugging of fluid flow.

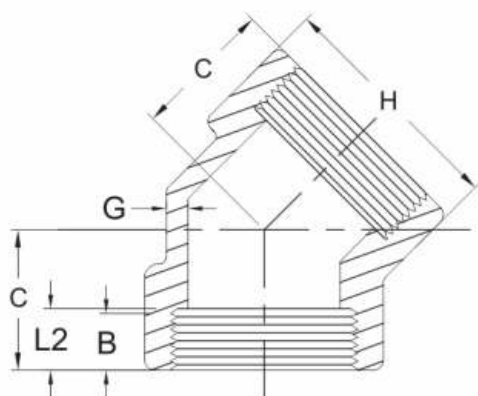

a structure for Application - Ash Handling Plant

Class Designation : 3000 Lbs

STANDARD REFERENCE : ASME B16.11 - 2011

NOMINAL SIZE		CENTER TO END C	OUTSIDE DIA H	Min. WALL THICKNESS G	MIN. LENGTH OF THD	
Inch	MM	Min.	Min.	Min.	B	L2
1/8"	6	17.00	22.0	3.18	6.4	6.7
1/4"	8	19.00	25.0	3.3	8.1	10.2
3/8"	10	22.00	33.0	3.51	9.1	10.4
1/2"	15	25.00	38.0	4.09	10.9	13.6
3/4"	20	28.00	46.0	4.32	12.7	13.9
1"	25	33.00	56.0	4.98	14.7	17.3
1¼"	32	35.00	62.0	5.28	17.0	18.0
1½"	40	43.00	75.0	5.56	17.8	18.4
2"	50	44.00	84.0	7.14	19.0	19.2
2½"	65	52.00	102.0	7.65	23.6	28.9
3"	80	64.00	121.0	8.84	25.9	30.5

ALL DIMENSIONS IN MM

Material is Available in - NPT, BSPT & BSP Threaded End Connection.



Threaded Socket / Coupling

THE NO.1 FORGED STEEL PIPE FITTINGS

▼ Art No. VS-3105

■ FORGED 3000 Lbs BLACK

'VS' fittings are being used in textile Industries also. Our threaded socket/coupling is a versatile component on almost every type of pipeline for plugging of fluid flow.



a structure for Application - Reaction Tank

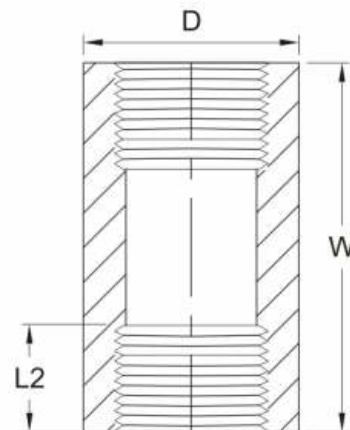

Class Designation : 3000 Lbs STANDARD REFERENCE : ASME B16.11 - 2011

NOMINAL SIZE	END TO END W	OUT SIDE DIAMETER D	THREAD LENGTH L2
	Min.	Min.	Min.
1/2"	48	28	13.6
3/4"	51	35	13.90
1"	60	44	17.30
1 1/4"	67	57	18.00
1 1/2"	79	64	18.40
2"	86	76	19.20
2 1/2"	92	92	28.90
3"	108	108	30.50

ALL DIMENSIONS IN MM



Threaded Union

FORGED 3000 Lbs BLACK

Art No. VS-3106 ▼

THE NO.1 FORGED STEEL PIPE FITTINGS



'VS' fittings are being used in textile Industries also. Our threaded union is a versatile component on almost every type of pipeline for plugging of fluid flow.

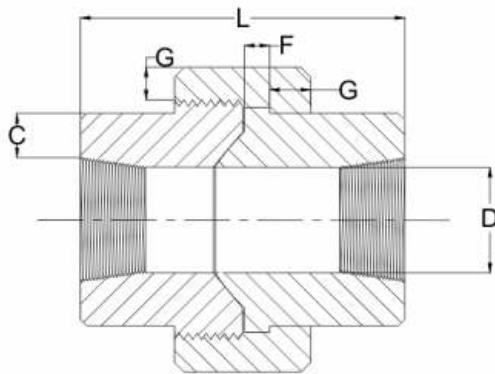

a structure for Application - Refineries

Class Designation : 3000 Lbs DIMENSIONS 'VS' THREADED UNION (STD. REF: MSS SP - 83 - 2006)

NOMINAL SIZE	SOCKET WALL THICKNESS	WATER WAY BORE		NUT	LENGTH ASSEM.
	C	D		G	L
	Min.	Min.	Max.	Min.	Nom.
1/4"	3.30	9.45	11.13	3.18	45
3/8"	3.51	13.51	14.27	3.43	50
1/2"	4.09	17.07	17.86	3.68	50
3/4"	4.27	21.39	23.01	4.06	60
1"	4.98	26.98	27.74	4.45	65
1 1/4"	5.28	35.36	37.69	5.21	75
1 1/2"	5.54	41.20	43.54	5.59	80
2"	6.05	52.12	55.58	6.35	90
2 1/2"	7.67	64.31	66.27	7.11	103

ALL DIMENSIONS IN MM

Material is Available in - NPT, BSPT & BSP Threaded End Connection.



Threaded Elbow 90°

THE NO.1 FORGED STEEL PIPE FITTINGS

FORGED 6000 Lbs BLACK

▼ Art No. VS-6101

These 'VS' fittings are synonymous to precision & they prove it in every field of application.



a structure for Application - Steam Hammers

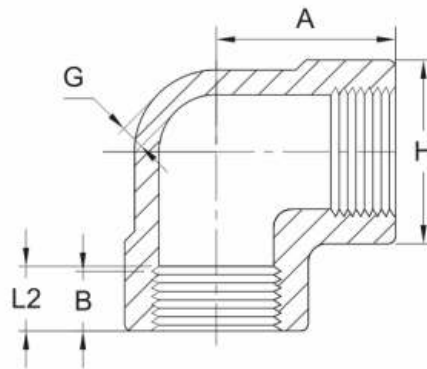

Class Designation : 6000 Lbs STANDARD REFERENCE : ASME B16.11 - 2011

NOMINAL SIZE		CENTER TO END A	OUTSIDE DIA H	Min. WALL THICKNESS G	MIN. LENGTH OF THD	
Inch	MM	Min.	Min.	Min.	B	L2
1/8"	6	25.00	25.00	6.35	6.4	6.7
1/4"	8	28.00	33.00	6.6	8.1	10.2
3/8"	10	33.00	38.00	6.98	9.1	10.4
1/2"	15	38.00	46.00	8.15	10.9	13.6
3/4"	20	44.00	56.00	8.53	12.7	13.9
1"	25	51.00	62.00	9.93	14.7	17.3
1¼"	32	60.00	75.00	10.59	17.0	18.0
1½"	40	64.00	84.00	11.07	17.8	18.4
2"	50	83.00	102.00	12.09	19.0	19.2
2½"	65	95.00	121.00	15.29	23.6	28.9
3"	80	106.00	146.00	16.64	25.9	30.5

ALL DIMENSIONS IN MM



Threaded Tee

FORGED 6000 Lbs BLACK

Art No. VS-6102 ▼

THE NO.1 FORGED STEEL PIPE FITTINGS



These 'VS' fittings are synonymous to precision & they prove it in every field of application.

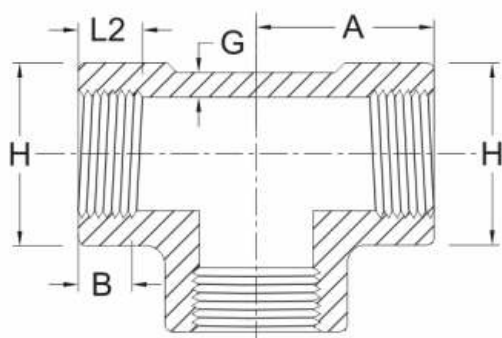

a structure for Application - Desalination Plant

Class Designation : 6000 Lbs

STANDARD REFERENCE : ASME B16.11 - 2011

NOMINAL SIZE		CENTER TO END A	OUTSIDE DIA H	Min. WALL THICKNESS G	MIN. LENGTH OF THD	
Inch	MM	Min.	Min.	Min.	B	L2
1/8"	6	25.0	25.0	6.35	6.4	6.7
1/4"	8	28.0	33.0	6.6	8.1	10.2
3/8"	10	33.0	38.0	6.98	9.1	10.4
1/2"	15	38.0	46.0	8.15	10.9	13.6
3/4"	20	44.0	56.0	8.53	12.7	13.9
1"	25	51.0	62.0	9.93	14.7	17.3
1 1/4"	32	60.0	75.0	10.59	17.0	18.0
1 1/2"	40	64.0	84.0	11.07	17.8	18.4
2"	50	83.0	102.0	12.09	19.0	19.2
2 1/2"	65	95.0	121.0	15.29	23.6	28.9
3"	80	106.0	146.0	16.64	25.9	30.5

ALL DIMENSIONS IN MM

Material is Available in - NPT, BSPT & BSP Threaded End Connection.



Threaded Cross

THE NO.1 FORGED STEEL PIPE FITTINGS

▼ Art No. VS-6103

■ FORGED 6000 Lbs BLACK

Ship building industries all over India rely on 'VS' fittings for pipe lines layout in ship building applications.



a structure for Application - Boilers

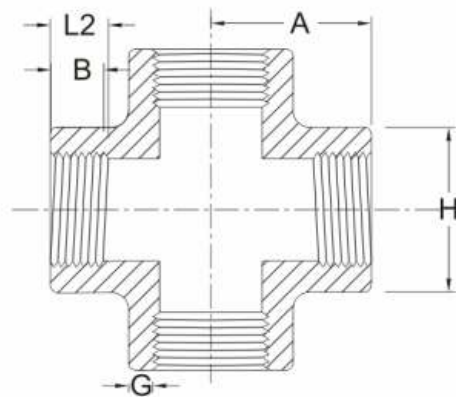

Class Designation : 6000 Lbs **STANDARD REFERENCE : ASME B16.11 - 2011**

NOMINAL SIZE		CENTER TO END A	OUTSIDE DIA H	Min. WALL THICKNESS G	MIN. LENGTH OF THD	
Inch	MM	Min.	Min.	Min.	B	L2
1/8"	6	25.00	25.00	6.35	6.4	6.7
1/4"	8	28.00	33.00	6.60	8.1	10.2
3/8"	10	33.00	38.00	9.98	9.1	10.4
1/2"	15	38.00	46.00	8.15	10.9	13.6
3/4"	20	44.00	56.00	8.53	12.7	13.9
1"	25	51.00	62.00	9.93	14.7	17.3
1¼"	32	60.00	75.00	10.59	17.0	18.0
1½"	40	64.00	84.00	11.07	17.8	18.4
2"	50	83.00	102.00	12.09	19.0	19.2

ALL DIMENSIONS IN MM



Threaded Elbow 45°

FORGED 6000 Lbs BLACK

Art No. VS-6104 ▼

THE NO.1 FORGED STEEL PIPE FITTINGS



'VS' fittings are being used in textile Industries also. Our threaded elbow is a versatile component on almost every type of pipeline for plugging of fluid flow.

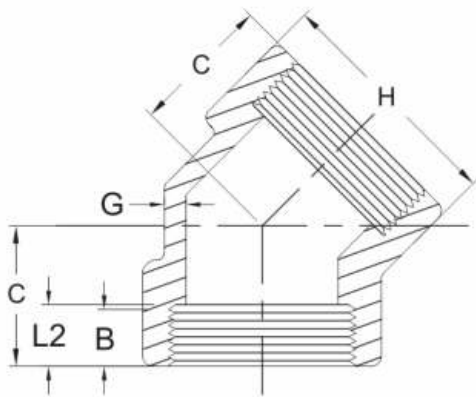

a structure for Application - Refineries

Class Designation : 6000 Lbs STANDARD REFERENCE : ASME B16.11 - 2011

NOMINAL SIZE		CENTER TO END C	OUTSIDE DIA H	Min. WALL THICKNESS G	MIN. LENGTH OF THD	
Inch	MM	Min.	Min.	Min.	B	L2
1/8"	6	19.0	25.0	6.35	6.4	6.7
1/4"	8	22.0	33.0	6.6	8.1	10.2
3/8"	10	25.0	38.0	6.98	9.1	10.4
1/2"	15	28.0	46.0	8.15	10.9	13.6
3/4"	20	33.0	56.0	8.53	12.7	13.9
1"	25	35.0	62.0	9.93	14.7	17.3
1¼"	32	43.0	75.0	10.59	17.0	18.0
1½"	40	44.0	84.0	11.07	17.8	18.4
2"	50	52.0	102.0	12.09	19.0	19.2

ALL DIMENSIONS IN MM

Material is Available in - NPT, BSPT & BSP Threaded End Connection.



Threaded Socket / Coupling

THE NO.1 FORGED STEEL PIPE FITTINGS

Art No. VS-6105

FORGED 6000 Lbs BLACK

'VS' fittings are being used in textile Industries also. Our threaded socket/coupling is a versatile component on almost every type of pipeline for plugging of fluid flow.



a structure for Application - Steam Hammers

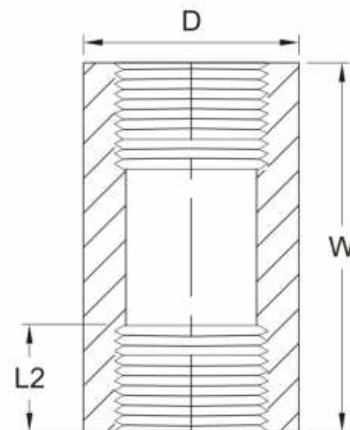

Class Designation : 6000 Lbs STANDARD REFERENCE : ASME B16.11 - 2011

NOMINAL SIZE	END TO END W	OUT SIDE DIAMETER D	THREAD LENGTH L2
	Min.	Min.	Min.
1/2"	48	38	13.6
3/4"	51	44	13.90
1"	60	57	17.30
1¼"	67	64	18.00
1½"	79	76	18.40
2"	86	92	19.20
2½"	92	108	28.90

ALL DIMENSIONS IN MM

Swage Nipple



THE NO.1 FORGED
STEEL PIPE FITTINGS





Swage Nipple

THE NO.1 FORGED STEEL PIPE FITTINGS

FORGED 3000 Lbs BLACK

▼ Art No. VS-3111

Manufacturing 'VS' pipe fittings for big industries units asks for perfection. Our fittings live up to those standards.



a structure for Application - Refineries

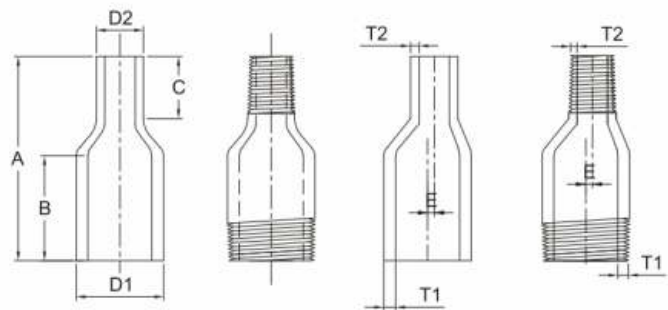

Class Designation : 3000 Lbs **STANDARD REFERENCE : BS 3799 : 1974**

NOMINAL SIZE		PARALLEL LENGTH, Min.			OUT SIDE DIAMETER		WALL THICKNESS		ECCENTRICITY
Inch	MM	A	B	C	D1	D2	T1	T2	T3
		MM	MM	MM	MM	MM	Sch (80) (XS)	Sch (80) (XS)	3000Lb
3/8"x1/4"	10x8	76	48	16	17.1	13.7	3.2	3.0	1.6
1/2"x3/8"	15x10	89	56	19	21.3	17.1	3.7	3.2	1.6
1/2"x1/4"	15x8	89	56	19	21.3	13.7	3.7	3.0	3.2
3/4"x1/2"	20x15	95	57	22	26.7	21.3	3.9	3.7	2.4
3/4"x3/8"	20x10	95	57	22	26.7	17.1	3.9	3.2	4.0
1"x3/4"	25x20	102	64	22	33.4	26.7	4.5	3.9	2.8
1"x1/2"	25x15	102	64	22	33.4	21.3	4.5	3.7	5.2
1 1/2"x1"	40x25	114	70	25	48.3	33.4	5.1	4.5	6.7
1 1/2"x3/4"	40x20	114	70	25	48.3	26.7	5.1	3.9	9.5
1 1/2"x1/2"	40x15	114	70	25	48.3	21.3	5.1	3.7	11.9
2"x1 1/2"	50x40	165	108	29	60.3	48.3	5.5	5.1	5.6
2"x1"	50x25	165	108	29	60.3	33.4	5.5	4.5	12.7
2"x3/4"	50x20	165	108	29	60.3	26.7	5.5	3.9	15.5
2"x1/2"	50x15	165	108	29	60.3	21.3	5.5	3.7	17.5
2 1/2"x2"	65x50	178	114	32	73.0	60.3	7.0	5.5	4.8
2 1/2"x1 1/2"	65x40	178	114	32	73.0	48.3	7.0	5.1	10.3
3"x2 1/2"	80x65	203	133	41	88.9	73.0	7.6	7.0	7.1
3"x2"	80x50	203	133	41	88.9	60.3	7.6	5.5	11.9
3"x1 1/2"	80x40	203	133	41	88.9	48.3	7.6	5.1	17.5
4"x3"	100x80	229	140	48	114.3	88.9	8.6	7.6	11.9
4"x2 1/2"	100x65	229	140	48	114.3	73.0	8.6	7.0	19.1



Swage Nipple

FORGED 6000 Lbs BLACK

Art No. VS-6111 ▼

THE NO.1 FORGED STEEL PIPE FITTINGS



Manufacturing 'VS' pipe fittings for big industries units asks for perfection. Our fittings live up to those standards.

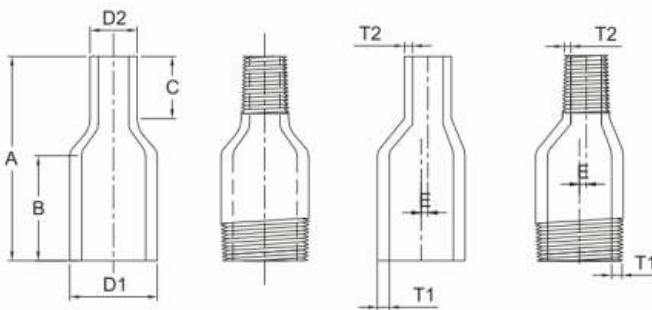

a structure for Application - Refineries

Class Designation : 6000 Lbs

STANDARD REFERENCE : BS 3799 : 1974



NOMINAL SIZE		PARALLEL LENGTH, Min.			OUT SIDE DIAMETER		WALL THICKNESS		WALL THICKNESS SCREWED		ECCENTRICITY E
		A	B	C	D1	D2	T1	T2	T1	T2	
Inch	MM	MM	MM	MM	MM	MM	Sch (160) (XS)	Sch (160) (XS)	XXS	XXS	6000Lb
3/8"x1/4"	10x8	76	48	16	17.1	13.7	4.0		6.4		1.6
1/2"x3/8"	15x10	89	56	19	21.3	17.1	4.8		7.5		1.6
1/2"x1/4"	15x8	89	56	19	21.3	13.7	4.8		7.5		3.2
3/4"x1/2"	20x15	95	57	22	26.7	21.3	5.6	4.8	7.8	7.5	2.4
3/4"x3/8"	20x10	95	57	22	26.7	17.1	5.6		7.8		4.0
1"x3/4"	25x20	102	64	22	33.4	26.7	6.4	5.6	9.1	7.8	2.8
1"x1/2"	25x15	102	64	22	33.4	21.3	6.4	4.8	9.1	7.5	5.2
1 1/2"x1"	40x25	114	70	25	48.3	33.4	7.1	6.4	10.2	9.1	6.7
1 1/2"x3/4"	40x20	114	70	25	48.3	26.7	7.1	5.6	10.2	7.8	9.5
1 1/2"x1/2"	40x15	114	70	25	48.3	21.3	7.1	4.8	10.2	7.5	11.9
2"x1 1/2"	50x40	165	108	29	60.3	48.3	8.7	7.1	11.1	10.2	5.6
2"x1"	50x25	165	108	29	60.3	33.4	8.7	6.4	11.1	9.1	12.7
2"x3/4"	50x20	165	108	29	60.3	26.7	8.7	5.6	11.1	7.8	15.5
2"x1/2"	50x15	165	108	29	60.3	21.3	8.7	4.8	11.1	7.5	17.5
2 1/2"x2"	65x50	178	114	32	73.0	60.3	9.5	8.7	14.0	11.1	4.8
2 1/2"x1 1/2"	65x40	178	114	32	73.0	48.3	9.5	7.1	14.0	10.2	10.3
3"x2 1/2"	80x65	203	133	41	88.9	73.0	11.1	9.5	15.2	14.0	7.1
3"x2"	80x50	203	133	41	88.9	60.3	11.1	8.7	15.2	11.1	11.9
3"x1 1/2"	80x40	203	133	41	88.9	48.3	11.1	7.1	15.2	10.2	17.5
4"x3"	100x80	229	140	48	114.3	88.9	13.5	11.1	17.1	15.2	11.9
4"x2 1/2"	100x65	229	140	48	114.3	73.0	13.5	9.5	17.1	14.0	19.1

ALL DIMENSIONS IN MM



RCF Registered

THE NO.1 FORGED STEEL PIPE FITTINGS

		Rail Coach Factory, Kapurthala		By Regd. Post	
		M/s Vijay Cycle & Steel Industries, A-8,A-9,Focal Point, Jalandhar 144004		Certificate of Registration S/KXH/V130070/Regn Date : 11.11.2013	
Ref : Your application No.VS/MGL/2012-13 Dated.29.03.2013					
In reference to your above, you are hereby registered with our Organization in following category					
Trade Group	Description of Item			Monetary limit: Upto ₹20 Lakhs (Upto ₹.Twenty Lakhs)	
0021	Forging light with machining			Vendor Code:V10053	
0022	Forging Medium with Machining			Type: Provisional	
0032	Components Involving Machining Only			Registration No. : V-1801	
234 Conditions of Registration :					
11.0 Any change in constitution (Address, Partnership deed, Memorandum, Article of Association etc) of your firm should be promptly communicated to this office.					
12.0 The issue of this registration certificate does not entitle you for getting tender enquiries in all cases and does not guarantee you any award of contract.					
13.0 The registration no. allotted to you should be quoted in all future correspondences with this office. This registration will not apply to any of your other branch/ office.					
14.0 You should apply for renewal of registration at least 3 months before expiry of validity along with following documents for this purpose:-					
14.1 Affidavit on non-judicial stamp paper that there has been no change in constitution of the company, The firm has not been banned by any Government organisation, No arbitration case is pending, no Recoveries are pending towards firm and will be no part of any cartel while quoting against Railway Tenders.					
14.2 Current & Valid ISO certificate and NSIC Certificate (if Registered with NSIC)					
14.3 Performance statement for supplies to RCF					
14.4 Details of tenders of RCF in which you have participated (in case no order awarded)					
14.5 Certified / Audited copies of commercial documents (Balance-sheet, profit & Loss Account, annual Report) of last financial years.					
15.0 You shall abide by IRS condition of contract and other rules of Railway administration as in force at present and as amended from time-to-time.					
16.0 RCF reserves the right to De-register/ Remove / Suspend your firm without giving any notice whatsoever.					
17.0 Any involvement of your firm in corrupt practices (such as Fraud, Misrepresentation, Cartel formation etc.) will tantamount to automatic de-registration.					
18.0 Monetary limit is for the purpose of deciding the value of PO for which you will be exempted from EMD/SD. However this does not entitle you for placement of order of this limit.					
19.0 Your quotation in tender for items (other than trade group mentioned in this tender will be treated at par with unregistered vendors.					
20.0 You should ensure availability of Digital Signature Certificate for participation in e-tenders of our Organization (visit https://irecs.gov.in).					
Address for communication : CMM Office, Administrative Building Rail Coach Factory, Hussainpur (Punjab) Pin-144602 Telephone: :01822-227792, Fax: 01822-228980 Website www.rcf.india.railways.gov.in				 (Jasvir Singh Arora) Dy. Chief Materials Manager/G For and On behalf of President of India	

**Forged Steel
Pipe Fittings with
threaded end connection
1000 Lbs.**



**THE NO.1 FORGED
STEEL PIPE FITTINGS**





Elbow 90°

THE NO.1 FORGED STEEL PIPE FITTINGS

FORGED 1000 Lbs BLACK

▼ Art No. VS-1001

Manufacturing 'VS' pipe fittings for big refineries asks for perfection. Our fittings live up to the required standards of perfection in quality and endurance.

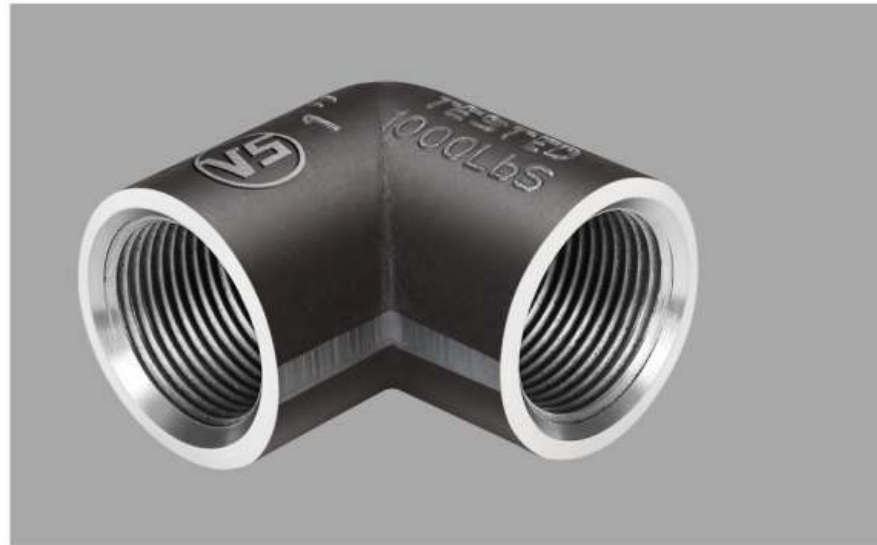

a structure for Application - Harbours

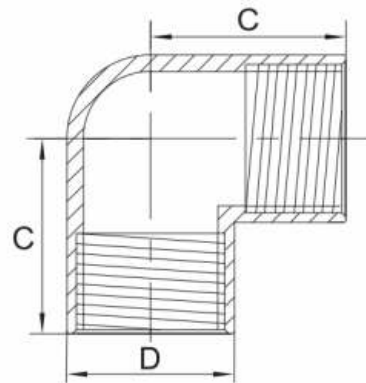

DIMENSIONS AS PER IS : 1239 (Part 2) 2011 / BS EN 10241 - 2000

NOMINAL SIZE OF OUTLET	MINIMUM LENGTH CENTER TO FACE	MINIMUM OUTER DIA
	C	D
6	16	15
8	22	18.5
10	24	22
15	32	27
20	35	32.5
25	43	39.5
32	51	49
40	52	56
50	64	68
65	76	84
80	89	98

ALL DIMENSIONS IN MM



Reducing Elbow 90°

FORGED 1000 Lbs BLACK

Art No. VS-1002 ▼

THE NO.1 FORGED STEEL PIPE FITTINGS

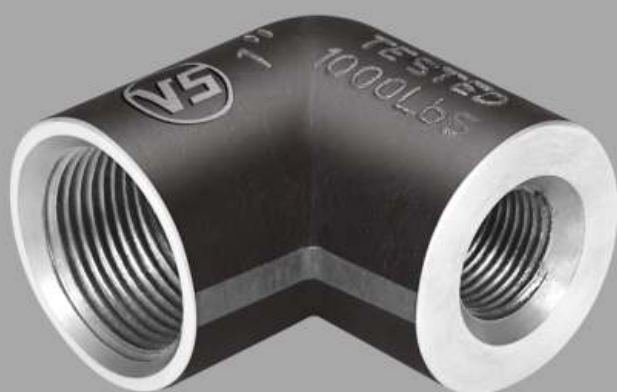

Manufacturing 'VS' pipe fittings for sugar mills asks for perfection. Our Reducing Elbow live up to the required standards of perfection from every angle.

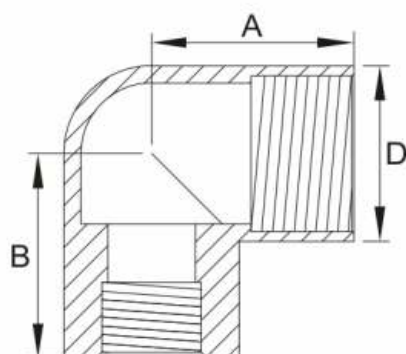

a structure for Application - Sugar Mills

DIMENSIONS AS PER IS : 1239 (Part 2) 2011 / BS EN 10241 - 2000

NOMINAL SIZE OF OUTLET	MIN. LENGTH OF CENTER TO FACE A	MIN. LENGTH OF CENTER TO FACE B	MINIMUM OUTER DIA D	NOMINAL SIZE OF OUTLET	MIN. LENGTH OF CENTER TO FACE A	MIN. LENGTH OF CENTER TO FACE B	MINIMUM OUTER DIA D
8x6	21	22	18.5	40x15	38	52	56
10x6	21	24	22	40x20	41	52	56
10x8	22	24	22	40x25	44	52	56
15x8	25	32	27	40x32	48	52	56
15x10	27	32	27	50x15	41	64	68
20x8	27	35	32.5	50x20	44	64	68
20x10	29	35	32.5	50x25	48	64	68
20x15	32	35	32.5	50x32	52	64	68
25x10	32	43	39.5	50x40	56	64	68
25x15	35	43	39.5	65x40	60	76	84
25x20	38	43	39.5	65x50	67	76	84
32x15	38	51	49	80x25	60	89	98
32x20	41	51	49	80x50	73	89	98
32x25	44	51	49				

ALL DIMENSIONS IN MM



Elbow 45°

THE NO.1 FORGED STEEL PIPE FITTINGS

▼ Art No. VS-1003

FORGED 1000 Lbs BLACK

Manufacturing these 'VS' pipe fittings for chemical applications like toxic gas handling is not like manufacturing any ordinary fitment. Fittings live upto those standards of rigidity and endurance perfectly.



a structure for Application - Gas Storage

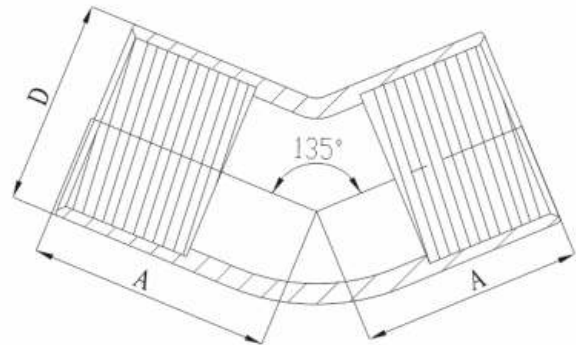

DIMENSIONS AS PER IS : 1239 (Part 2) 2011 / BS EN 10241 - 2000

NOMINAL SIZE OF OUTLET	MINIMUM LENGTH CENTER TO FACE	MINIMUM OUTER DIA
	A	D
6	16	15
8	17	18.5
10	19	22
15	22	27
20	27	32.5
25	33	39.5
32	38	49
40	44	56
50	51	68
65	60	84
80	73	98

ALL DIMENSIONS IN MM



Male / Female Elbow 90°

FORGED 1000 Lbs BLACK

Art No. VS-1004 ▼

THE NO.1 FORGED STEEL PIPE FITTINGS



Manufacturing 'VS' pipe fittings for sugar mills asks for perfection. Our Elbow Male/Female live up to the required standards of perfection from every angle.

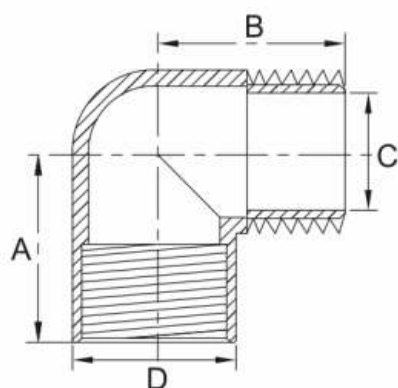

a structure for Application - Paper Mills

DIMENSIONS AS PER IS : 1239 (Part 2) 2011 / BS EN 10241 - 2000

NOMINAL SIZE OF OUTLET	MIN. LENGTH OF CENTER TO FACE A	MIN. LENGTH OF CENTER TO FACE B	BORE DIA OF MALE END C		MINIMUM OUTER DIA D
			Min.	Max.	
8	19	27	6.5	8	18.5
10	21	29	8.5	10.5	22
15	25	35	11.5	13	27
20	30	40	18	21	32.5
25	37	46	24	26	39.5
32	43	54	30	32	49
40	49	57	37	39	56
50	59	70	48	51	68
65	68	83	62	66	84
80	81	94	75	79	98

ALL DIMENSIONS IN MM



Tee

THE NO.1 FORGED STEEL PIPE FITTINGS

▼ Art No. VS-1005

FORGED 1000 Lbs BLACK

Forged steel 'VS' fittings for petrochemical industries require high quality, long life & total safety. Our fittings are made to fit these requirements.



a structure for Application - ONGC

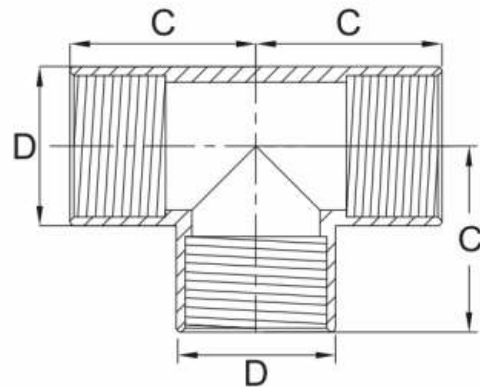

DIMENSIONS AS PER IS : 1239 (Part 2) 2011 / BS EN 10241 - 2000

NOMINAL SIZE OF OUTLET	MINIMUM LENGTH CENTER TO FACE	MINIMUM OUTER DIA
	C	D
6	16	15
8	22	18.5
10	24	22
15	32	27
20	35	32.5
25	43	39.5
32	51	49
40	52	56
50	64	68
65	76	84
80	89	98

ALL DIMENSIONS IN MM



Reducing Tee

FORGED 1000 Lbs BLACK

Art No. VS-1006 ▼

THE NO.1 FORGED STEEL PIPE FITTINGS



Our 'VS' fittings proved their operational superiority on fuel gas systems and are number one. These tees are made to perfection.

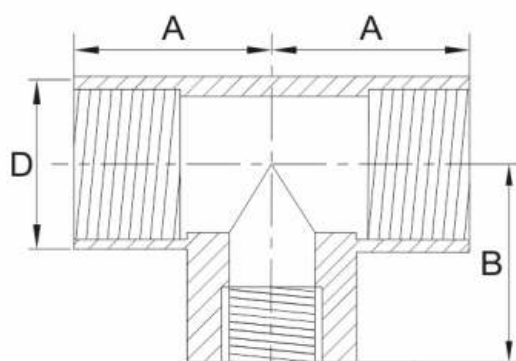

a structure for Application - Fuel Gas Transmission

DIMENSIONS AS PER IS : 1239 (Part 2) 2011 / BS EN 10241 - 2000

NOMINAL SIZE OF OUTLET	MIN. LENGTH OF CENTER TO FACE A	MIN. LENGTH OF CENTER TO FACE B	MINIMUM OUTER DIA D	NOMINAL SIZE OF OUTLET	MIN. LENGTH OF CENTER TO FACE A	MIN. LENGTH OF CENTER TO FACE B	MINIMUM OUTER DIA D
8x6	21	22	18.5	40x20	41	52	56
10x6	21	24	22	40x25	48	52	56
10x8	22	24	22	40x32	49	52	56
15x8	25	32	27	50x15	41	64	68
15x10	27	32	27	50x20	44	64	68
20x8	27	35	32.5	50x25	48	64	68
20x10	29	35	32.5	50x32	52	64	68
20x15	32	35	32.5	50x40	56	64	68
25x10	30	43	39.5	65x40	60	76	84
25x15	35	43	39.5	65x50	67	76	84
25x20	38	43	39.5	80x25	60	89	98
32x15	38	51	49	80x32	64	89	98
32x20	41	51	49	80x40	67	89	98
32x25	44	51	49	80x50	73	89	98
40x15	38	52	56	80x65	79	89	98

ALL DIMENSIONS IN MM



Cross

THE NO.1 FORGED STEEL PIPE FITTINGS

▼ Art No. VS-1007

FORGED 1000 Lbs BLACK

These 'VS' fittings are normally used in hot fluids and steam applications. Our fittings need to be equally perfect from all ends.



a structure for Application - Sugar Mills

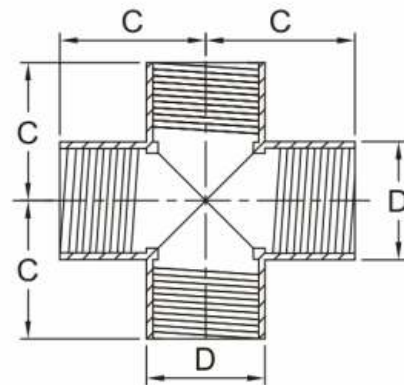

DIMENSIONS AS PER IS : 1239 (Part 2) 2011 / BS EN 10241 - 2000

NOMINAL SIZE OF OUTLET	MINIMUM LENGTH CENTER TO FACE	MINIMUM OUTER DIA
	C	D
6	16	15
8	22	18.5
10	24	22
15	32	27
20	35	32.5
25	43	39.5
32	51	49
40	52	56
50	64	68
65	76	84
80	89	98

ALL DIMENSIONS IN MM



Union

FORGED 1000 Lbs BLACK

Art No. VS-1008 ▼

THE NO.1 FORGED STEEL PIPE FITTINGS



Perfect threading and connection are what our 'VS' fittings are known for. Our forged steel fittings are much sought after in railways due to their ruggedness and reliable service life.

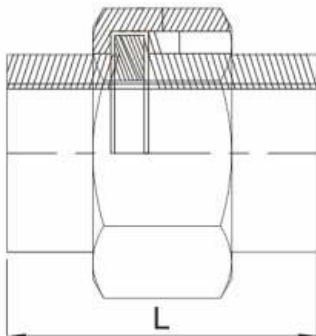

a structure for Application - Railways

DIMENSIONS AS PER IS : 1239 (Part 2) 2011 / BS EN 10241 - 2000

NOMINAL SIZE OF OUTLET	MINIMUM LENGTH
	L
6	38
8	44
10	51
15	57
20	67
25	76
32	85
40	100
50	110
65	120
80	135

ALL DIMENSIONS IN MM



Socket / Coupling

THE NO.1 FORGED STEEL PIPE FITTINGS

▼ Art No. VS-1009

FORGED 1000 Lbs BLACK

Our 'VS' fittings true to their name are very reliable in any pipe line network which is very essential in harbours.



a structure for Application - Harbours

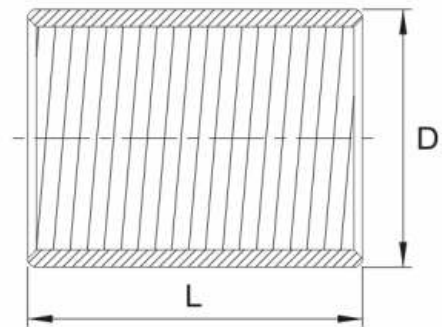

DIMENSIONS AS PER IS : 1239 (Part 2) 2011 / BS EN 10241 - 2000

NOMINAL SIZE OF OUTLET	MINIMUM LENGTH L	MINIMUM OUTER DIA D
6	19	15
8	27	18.5
10	28	22
15	37	27
20	39	32.5
25	46	39.5
32	51	49
40	51	56
50	60	68
65	69	84

ALL DIMENSIONS IN MM



Reducing Socket / Coupling

FORGED 1000 Lbs BLACK

Art No. VS-1010 ▼

THE NO.1 FORGED STEEL PIPE FITTINGS



Manufacturing these 'VS' Reducing Sockets, is a work of art which we have perfected from all angles.

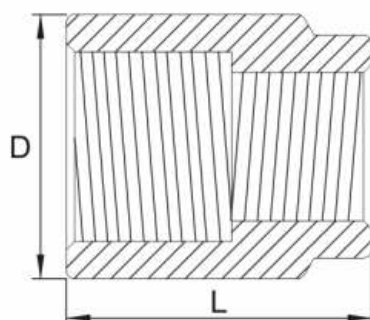

a structure for Application - ONGC

DIMENSIONS AS PER IS : 1239 (Part 2) 2011 / BS EN 10241 - 2000

NOMINAL SIZE OF OUTLET	MINIMUM LENGTH L	MINIMUM OUTER DIA D	NOMINAL SIZE OF OUTLET	MINIMUM LENGTH L	MINIMUM OUTER DIA D
8x6	25	18.5	32x20	57	49
10x6	30	22.0	32x25	56	49
10x8	29	22.0	40x15	65	56
15x6	41	27	40x20	64	56
15x8	40	27	40x25	62	56
15x10	38	27	40x32	60	56
20x8	44	32.5	50x15	70	68
20x10	43	32.5	50x20	68	68
20x15	41	39.5	50x25	67	68
25x8	54	39.5	50x32	65	68
25x10	52	39.5	50x40	64	68
25x15	51	32.5	65x25	76	84
25x20	49	32.5	65x32	75	84
32x10	60	49	65x40	73	84
32x15	59	49	65x50	71	84

ALL DIMENSIONS IN MM



Hex. Nipple

THE NO.1 FORGED STEEL PIPE FITTINGS

FORGED 1000 Lbs BLACK

▼ Art No. VS-1011

Our 'VS' fittings have been most successfully used on pneumatic lines. Manufacturing Hex. Nipples means perfecting both the ends.



a structure for Application - Pneumatics

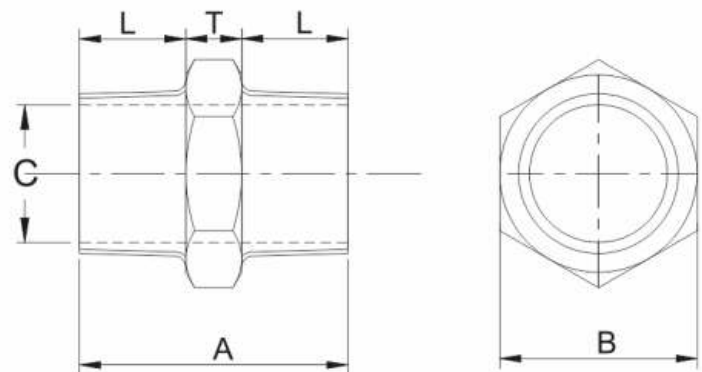

DIMENSIONS AS PER IS : 1239 (Part 2) 2011 / BS EN 10241 - 2000

NOMINAL BORE	MIN.LENGTH OF THREAD FOR BASIS GAUGE LENGTH PLUS DIA CLEARANCE L	THICKNESS OF HEXAGON T	MINIMUM OVERALL LENGTH A	MINIMUM DIAMETER OF BORE C	WIDTH ACROSS FLATS OF HEXAGON B
6	9.5	6	25	5.5	13.1
8	12.5	6	31	6.5	15.5
10	12.5	8	33	9.5	17.9
15	17.5	8	43	12.5	23.0
20	19	10	48	19	27.8
25	21	10	52	25	35.3
32	24	11	59	32	47.2
40	24	13	61	38	52.0
50	27	14	68	51	61.1
65	32	16	80	64	79.0
80	35	19	89	76	92.0

ALL DIMENSIONS IN MM



Reducing Hex. Nipple

FORGED 1000 Lbs BLACK

Art No. VS-1012 ▼

THE NO.1 FORGED STEEL PIPE FITTINGS



When ever the word automobiles is used, it personifies strength & our 'VS' fittings mean strength in every way.

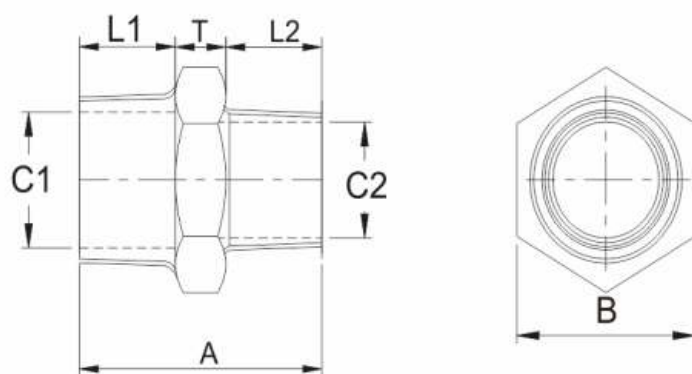

a structure for Application - Automobile Industry

DIMENSIONS "VS" REDUCING HEX. NIPPLE

NOMINAL BORE	MIN.LENGTH OF THREAD FOR BASIS GAUGE LENGTH PLUS DIA CLEARANCE		THICKNESS OF HEXAGON	MINIMUM OVERALL LENGTH	MINIMUM DIAMETER OF BORE		WIDTH ACROSS FLATS OF HEXAGON
	L1	L2			T	A	
8x6	12.5	9.5	6	28	6.5	5.5	15.5
10x8	12.5	12.5	8	33	9.5	6.5	17.9
15x8	17.5	12.5	8	38	12.5	6.5	23.0
15x10	17.5	12.5	8	38	12.5	9.5	23.0
20x10	19	12.5	10	41.5	19	9.5	27.8
20x15	19	17.5	10	46.5	19	12.5	27.8
25x15	21	17.5	10	48.5	25	12.5	35.3
25x20	21	19	10	50	25	19	35.3
32x20	24	19	11	54	32	19	47.2
32x25	24	21	11	56	32	25	47.2
40x25	24	21	13	58	38	25	52.0
40x32	24	24	13	61	38	32	52.0
50x32	27	24	14	65	51	32	61.1
50x40	27	24	14	65	51	38	61.1

ALL DIMENSIONS IN MM



Plug

THE NO.1 FORGED STEEL PIPE FITTINGS

▼ Art No. VS-1013

FORGED 1000 Lbs BLACK

'VS' fittings are being used in textile Industries also. Our plug is a versatile component on almost every type of pipeline for plugging of fluid flow.



a structure for Application - Textiles

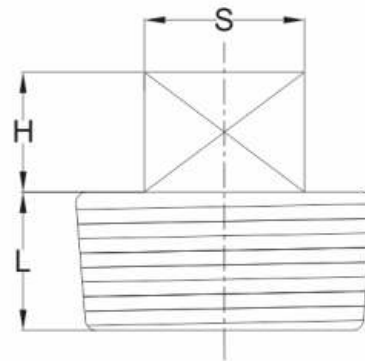

DIMENSIONS AS PER IS : 1239 (Part 2) 2011 / BS EN 10241 - 2000

NOMINAL SIZE	MIN. LENGTH OF THREAD FOR BASIC GAUGE	APPROX. SIZE OF SQUARE	APPROX. HEIGHT OF SQUARE
	L	S	H
6	6.5	6	6
8	9.7	9	6
10	10.1	11	10
15	13.2	13	10
20	14.5	14	12
25	16.8	17	12
32	19.1	22	16
40	19.1	27	16
50	23.4	32	19
65	26.7	37	19
80	29.8	37	22

ALL DIMENSIONS IN MM



Hex. Bush

FORGED 1000 Lbs BLACK

Art No. VS-1014 ▼

THE NO.1 FORGED STEEL PIPE FITTINGS



Manufacturing these 'VS' fittings for fire fighting applications require a lot of consistency and skill and certainly our product meets those standards.

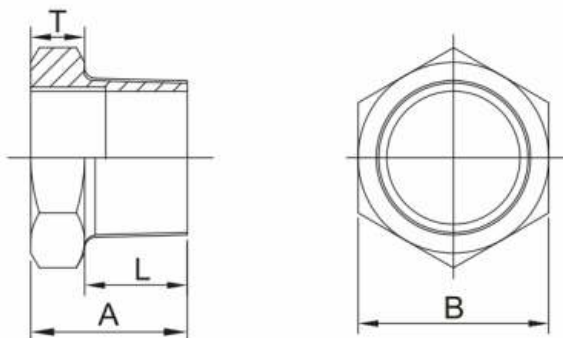

a structure for Application - Fire Fighting

DIMENSIONS AS PER IS : 1239 (Part 2) 2011 / BS EN 10241 - 2000

NOMINAL SIZE MM	MIN.LENGTH OF USEFUL THREADS FOR BASIC GAUGE LENGTHS PLUS CLEARANCE L	THICKNESS OF HEXAGON MAX. T	OVERALL LENGTH MIN. A	WIDTH ACROSS FLATS OF HEXAGON B
8x6	12.5	6	18.5	15.5
10x8	12.5	7	20.5	17.9
15x8	17.5	8	25.5	23.0
15x10	17.5	7	25.5	23.0
20x10	19	10	29	27.8
20x15	19	10	29	27.8
25x15	21	10	31	35.3
25x20	21	10	31	35.3
32x15	24	11	35	47.2
32x20	24	11	35	47.2
32x25	24	11	35	47.2
40x20	24	13	37	52.0
40x25	24	13	37	52.0
40x32	24	13	37	52.0
50x25	27	14	41	61.1
50x32	27	14	41	61.1
50x40	27	14	41	61.1



Our Associates

THE NO.1 FORGED STEEL PIPE FITTINGS



IndianOil



Indian Railways



VOLTAS

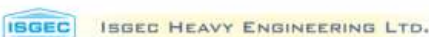

UM GROUP





Other Range of Products

THE NO.1 FORGED STEEL PIPE FITTINGS



Art No. VS-1051
Elbow Union



Art No. VS-1050
Elbow Male/Male



Art No. VS-1053
Elbow Hot Galvanized



Art No. VS-1054
Half Socket



Art No. VS-3061
Sockolet



Art No. VS-1055
Tee Male/Female



Art No. VS-IBR-3062
**Elbow Socket Weld
IBR Approved**



Art No. VS-IBR-3063
**Tee Socket Weld
IBR Approved**



THE NO.1
FORGED STEEL
PIPE FITTINGS

VIJAY CYCLE & STEEL INDUSTRIES

A8-A9, Focal Point, Jalandhar - 144 004 INDIA
Phones : 91-0181-2604001-2-3, Fax : 91-181-2604004
E-mail : info@vsfittings.com Website : www.vsfittings.com