



**FLUID SEALS (INDIA)<sup>TM</sup>**

AN ISO 9001 : 2008 CERTIFIED COMPANY

*a device of fluid sealing*



*Mfg. of Mechanical Shaft Seal & Components*

## COMPANY PROFILE

FLUID SEALS (India)™ An ISO 9001 : 2008 Certified Company is primarily into manufacturing of all types Mechanical Shaft Seals & Agitator Seal.

We manufacture a wide range of Mechanical Sales extending from simple water pump Seals to highly sophisticated pressure balanced, hydro dynamically balanced, single and double Seals for pumps, agitator, autoclaves, cartridge seals, compressor seal, pump seal, pump spares etc.

### He Product Range :

- By design of Mechanicals Seals
- Equivalent range of complete mechanical shaft seals & spares for leaving brands like John Crane, Burgmann, Flowserve etc as well as are provide to customer mechanical seal as per requirement. Just send us a sample or drawing.
- Repairs & maintenance of any types Mechanical Shaft Seals.

FLUID SEALS (India)™ An ISO 9001 : 2008 Certified Company we give total customer satisfaction by quality, Technical Support & Delivery on Time.

Thanks & Best Regards,  
FLUID SEALS (India)™

## CARTRIDGE SEAL

**FSI C62** Cartridge seals are self-contained units consisting of a shaft sleeve, seal, and gland plate. The unit is fitted onto the pump shaft as a built assembly, and no further fitting is required. Cartridge seals are an attempt to over-come the fitting problems of conventional seals. They are supplied in single and double form, and the gland plate is often fitted with various tappings to provide for flushing, cooling water injection, and disaster control. The cartridge can overcome several limitations of the standard pump gland. Tangential tappings for introducing fluids into the gland cause less disturbance to the seal face than the radial tappings often found on pump units. Look again at the tapping provided for flush water to the packed gland, a

tangential tapping would provide a less turbulent water source. For a packing gland this may not be important but to a mechanical seal it can be another adverse condition with which to cope.

The setting position of the seal is set by the cartridge design, but the seal unit should not be screwed to the shaft until the gland plate is secured to the pump and any adjustments made to the shaft position. Once this has been completed the set screws can be tightened and the spacers removed.

So, what can go wrong. The design works to eliminate many of the common causes of seal failure on installation and because the seal is presented on its own shaft sleeve any damage that might be caused by a conventional seal to the pump unit is also eliminated.



### Materials

Seal Faces : Ceramic / Sic/Carbon Vs Ceramic / RB Sic./TC  
Secondary Seals : Viton/PTFE/GFT  
Metal Components : SS-316 / SS-304

### Operating Limits :

Shaft Dia. : 25 to 150mm  
Pressure : up to 15 Bars  
Temp. : -50 to 180°C  
Speed : up to 25 m/s

## SINGLE COIL SPRING BALANCED SEAL

**TYPE FSI 25** : are single coil balanced mechanical seals, reliable & rugged enough for variety of applications. Designated as FSI 25 & FSI 26 for 'O' Ring & PTFE wedge type Secondary Seals respectively. The balanced & unbalanced version can just be obtained by simply changing the carbon face assembled through circlip provided. Non-clogging spring design enables these seals to be reliably used in situations involving abrasive, corrosive and viscous media. generally handled by high-pressure pumps.



### Applications :

Used in high pressure pumps, refineries, fertilizers, nuclear plants & petroleum products.

### Material :

Seal Faces : Carbon Vs Sic./TC  
Secondary Seals : Viton/PTFE/GFT  
Metal Components : SS-316 / SS-304

### Operating Limits :

Shaft Dia : 10 to 150mm  
Pressure : up to 30 Bars  
Temp. : -50 to 180°C  
Speed : up to 15 m/s

## CONICAL SPRING UNBALANCED SEAL

**Type FSI 12** is Single-coil conical spring unbalanced seal.

The FSI 12 series seal are extremely rugged & reliable & therefore used in wide range of sealing applications.

These Seals have very few parts & hence can be easily assembled or dismantled. The seals arrangement does not warrant any modification even in case of conversion from gland packing.

The compact design eliminates the requirement of extra radial & axial space for its installation.

### Applications :

Generally used for handling corrosive chemicals, hydrocarbons, general & light chemicals

### Materials

Seal Faces : Sic/carbon/TC Vs Ceramic/Sic./TC  
Secondary Seals : Viton/PTFE/GFT  
Metal Components : SS-316 / SS-304

### Operating Limits :

Shaft Dia. : 10 to 100mm  
Pressure : up to 10 Bars  
Temp. : -50 to 180°C  
Speed : up to 25 m/s



## SINGLE COIL SPRING UNBALANCED SEAL

**TYPE FSI 13** : are single coil unbalanced seals, these seals are simple in design & reliable & rugged enough for the most difficult applications. In FSI 13 'V' packing used as Secondary seals respectively. Special notches enhance the required driving torque & hence the seal is independent of direction of rotation. Non-clogging spring design enables these seals to be reliably

used in situations involving abrasive, corrosive & viscous fluids generally handled by high Temperature pumps.

### Applications :

Generally used in refineries, fertilizers, nuclear plants & petroleum pipelines.

### Material :

Seal Faces : Carbon/TC/Sic. Vs  
Ceramic/RB Sic./Tc  
Secondary Seals : Viton/PTFE/GFT  
Metal Components : SS-316 / SS-304

### Operating Limits :

Shaft Dia : 25 to 150mm  
Pressure : up to 10 Bars  
Temp. : -50 to 280°C  
Speed : up to 15 m/s



## MULTI SPRING UNBALANCED SEAL

**TYPE FSI 22U** : are general-purpose multi spring unbalanced seals. Designated as FSI 22B for the unbalanced Versions with 'O' Ring & PTFE wedge respectively. Shaft fretting is minimized due to lower spring loads provided through wedge or 'O' Rings, occupies less stuffing box area due to its narrow cross-section & compact design.



These Seals can be easily assemble or dismantled through circlip provided & cab be change to Balance version of its type merely by changing the carbon face only & an be provided with single, double or tandem arrangement worth external seal support systems & devices.

### Applications :

Generally used in Petrochemicals, Light Hydrocarbons & General Industrial Fluids.

### Materials

Seal Faces : Carbon vs Ceramic/Sic./TC  
Secondary Seals : Viton/PTFE/GFT  
Metal Components : SS-316 / SS-304

### Operating Limits :

Shaft Dia. : 14 to 150mm  
Pressure : up to 10 Bars  
Temp. : -50 to 280°C  
Speed : up to 25 m/s

## MULTI SPRING BALANCED SEAL

**TYPE FSI 22B** : are pushers type balanced multi spring seals generally used where high-pressure sealing is required. Due to its compact radial & axial dimensions these seals required lower stuffing box space for installation. These seals can be provided with single, double or tandem arrangement with external seal support systems & devices.

### Applications :

Generally used in Petrochemicals, Petroleum refinery, Light Hydrocarbons & General Industrial fluids.

### Materials

Seal Faces : Carbon vs Ceramic/Sic./TC  
Secondary Seals : Viton/PTFE/GFT  
Metal Components : SS-316 / SS-304

### Operating Limits :

Shaft Dia. : 14 to 150mm  
Pressure : up to 30 Bars  
Temp. : -50 to 280°C  
Speed : up to 25 m/s



## MULTI SPRING REVERSED BALANCED SEAL

**TYPE FSI 22R** : is externally mounted internally balanced multi spring seal. The unique feature of this type of seal is that, it eliminated the shaft step or sleeves for balancing. These seals are externally mounted & hence the metal parts including the

springs do not come in contact with the circulating media & therefore can be use for corrosive or abrasive media sealing. The compact design eliminates the requirement of extra radial & axial space for its installation.

### Applications :

Generally used for handling corrosive chemicals, hydrocarbons, general & light chemicals.

### Materials

Seal Faces : Sic/carbon vs Ceramic/Sic./TC  
Secondary Seals : Viton/PTFE/GFT  
Metal Components : SS-316 / SS-304

### Operating Limits :

Shaft Dia. : 10 to 100mm  
Pressure : up to 10 Bars  
Temp. : -50 to 180°C  
Speed : up to 25 m/s



## TEFLON BELLOW SEAL

**TYPE FSI 31T** : are Teflon Bellow seals designed to handle highly corrosive liquids. These seals are outside mounted with simple installation procedure and hence cost effective for corrosive media sealing. Type FSI 31T & FSI 32T designated as Fixed & replaceable bellow face respectively. For replaceable version there is flexibility for selection of face material as per the

media to sealed, which can be easily removed & replaced & is highly desirable in severe applications.

### Applications :

Used in acids, alkalis & extremely corrosive services.

### Materials

Seal Faces : GFT/Sic./Carbon vs Ceramic/Sic.

Secondary Seals : PTFE

Metal Components : SS-316/Hast-C

### Operating Limits :

Shaft Dia. : 18 to 100mm

Pressure : up to 5 Bars

Temp. : -20 to 80°C

Speed : up to 25 m/s



## WELDED ENDS METAL BELLOW SEAL

**TYPE FSI 10** : is Inherently balanced metal bellow seal. This seals are independent of direction of rotation. The unique feature of this type of seal is that, there is no dynamic 'O' rings and therefore it will never hangup or damage the shaft and sleeve, it also has an ability to handle corrosive as well as abrasive & viscous media. These seals have self-cleaning & non-clogging construction. With selection of special bellow material it can be used in highly corrosive media.

### Applications :

Generally used in for handling highly corrosive chemicals, high Temperature applications, petroleum refinery etc.

### Material :

Seal Faces : Carbon/TC/ Vs Sic./Tc

Secondary Seals : Viton/PTFE/GFT/Graphite

Metal Components : SS-316 / SS-304

### Operating Limits :

Shaft Dia : 19 to 100mm

Pressure : up to 15 Bars

Temp. : -50 to 350°C

Speed : up to 25 m/s

### Bellow Material :

- Hast-alloy-C
- Alloy 20
- AM305
- Inconel 625
- Alloy C 276



## SINGLE COIL SPRING ELASTOMER BELLOW SEAL

**Type FSI 14** has been designed for general sealing purpose which includes easy installation of the seal.

FSI14 has a unique rubber bellow secondary seal, which provides a high degree of axial flexibility to compensate for lack of concentricity of the shaft & misalignment & wear due to thrust movement of the shaft.

The seal can be use regardless of direction of rotation since the driving torque is not transmitted through the coil spring. The required driving torque is enhanced through the unique rubber bellow which fits on the shaft through the interference fit between the collar, rubber bellow & the shaft.

### Applications :

Generally used in hot & cold-water pumps, Oil pumps, refrigeration compressor & fuel injection pumps.

### Materials

Seal Faces : Carbon Vs Ceramic/Sic./TC

Secondary Seals : Nitrile / Neoprene/Viton

Metal Components : SS-304

### Operating Limits :

Shaft Dia. : 10 to 100mm

Pressure : up to 10 Bars

Temp. : -20 to 180°C

Speed : up to 25 m/s



## GENERAL PURPOSE RUBBER BELLOW SEAL

**TYPE FSI 20** : are most commonly used rubber bellow seal, Due to its compact design it can be easily mounted. TYPE FSI 20 has a unique rubber bellow secondary seal, which provides a high degree of axial flexibility to compensate for lack of concentricity of the shaft & misalignment & wear due to thrust movement of the shaft.

The seal can be use regardless of direction of rotation since the driving torque is not transmitted through the coil spring, The required driving torque is enhanced through the unique rubber bellow which fits on the shaft. There are no bonded Joints and all the face materials are interchangeable without having to modify any dimensions.



### Applications :

Generally used in sewage applications, waste water pumps & fuel injection pumps.

### Material :

Seal Faces : Carbon Vs Ceramic / Sic./TC  
Secondary Seals : Nitrile / Neoprene / Viton  
Metal Components : SS-304

### Operating Limits :

Shaft Dia : 10 to 100mm  
Pressure : up to 10 Bars  
Temp. : -20 to 150°C  
Speed : up to 25 m/s

## DRY RUNNING AGITATOR SEAL

**TYPE FSI 101** : seals are outside mounted balanced seal, which require no shaft or sleeve step for balancing FSI 101 seal shows good performance in high vacuum conditions. Since no auxiliary equipments are needed for installation, it is very cost effective & economical. These seal can be easily installed & repaired on the field to minimized replacements costs & downtime.

### Main features of the FSI 101 dry running seals are :

- Simple, rugged drive design that withstands shaft movement vibration & deflection.
- Seal design eliminates the need of auxiliary equipments for cooling & lubricants for mixer application.
- It eliminates the possibility of product contamination, since there is no use of barrier fluid.
- Can be used in high vacuum applications.
- These seals are very cost effective.

Seals with bearing can be provided for vessels having greater misalignments with special arrangement.

### Applications :

Used in top entry mixer vessels in pharmaceuticals & chemical industries.

### Material :

Seal Faces : Carbon/Sic/TC  
Secondary Seals : Viton/EPR/PTFE/GFT/AFLAS/FFKM  
Metal Components : SS-316/304

### Operating Limits :

Shaft Dia : 15 to 100mm  
Pressure : up to 1.40 MPa  
Temp. : -20 to 120°C  
Speed : up to 1 m/s

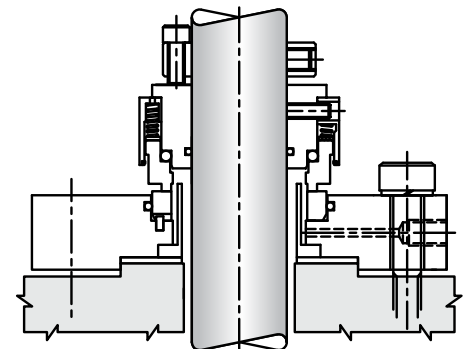

## TOP ENTRY AGITATOR DOUBLE SEAL

**TYPE FSI 101B** : is a top entry agitator double mechanical seal designed for medium to high-pressure applications.

These seal are successfully used for many years in all kinds of mixers, reactors, driers & mills in the Pharmaceuticals, Paints, Pulp & Plastic industries.

These seals are factory assembled with cartridge unit & therefore can be easily installed without disturbing the delicate mating faces.

For larger shaft deflection special version with integrated floating bearing is provided

### Applications :

Used in Pulper, Plastics & Pharmaceuticals industries

### Material :

Seal Faces : Carbon/Sic./TC Vs Ceramic/Sic/TC  
Secondary Seals : Nitrile/Neoprene/Viton/PTFE  
Metal Components : SS-316 / SS-304

### Operating Limits :

Shaft Dia : 40 to 200mm  
Pressure : up to 60 Bars  
Temp. : -20 to 200°C  
Speed : up to 25 m/s

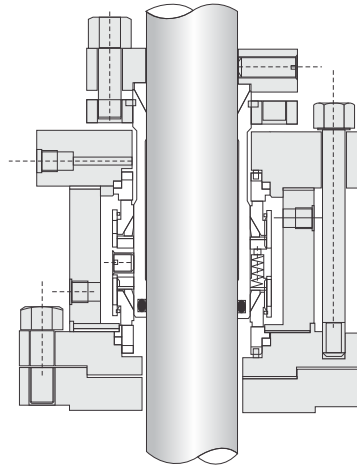

## DRY RUNNING AGITATOR SEAL

**TYPE FSI 102** : seals are outside mounted balanced seal, which require no shaft or sleeve step for balancing FSI 102 seal shows good performance in high vacuum conditions. Since no auxiliary equipments are needed for installation, it is very cost effective & economical. These seal can be easily installed & repaired on the field to minimized replacements costs & downtime.

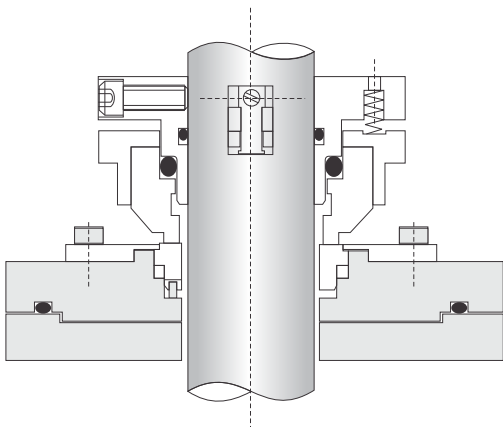

### Main features of the FSI 102 dry running seals are :

- Simple, rugged drive design that withstands shaft movement vibration & deflection.
- Seal design eliminates the need of auxiliary equipments for cooling & lubricants for mixer application.
- It eliminates the possibility of product contamination, since there is no use of barrier fluid.
- Can be used in high vacuum applications.
- These seals are very cost effective.

Seals with bearing can be provided for vessels having greater misalignments with special arrangement.

### Applications :

Used in top entry mixer vessels in pharmaceuticals & chemical industries.

### Material :

Seal Faces : Carbon Vs Ceramic/Sic/TC  
Secondary Seals : Nitrile/Neoprene/Viton/PTFE  
Metal Components : SS-316 / SS-304

### Operating Limits :

Shaft Dia : 25 to 100mm  
Pressure : up to 1.40 MPa  
Temp. : -10 to 150°C  
Speed : up to 1 m/s



# FLUID SEALS (INDIA)<sup>TM</sup>

AN ISO 9001 : 2008 CERTIFIED COMPANY

**Mfg. of Mechanical Shaft Seals & Components**

Office : A/10 & A/3, Shukla Ind. Estate, Singh Comp., Opp. Ajit Glass, S.V. Road,  
Jogeshwari (W), Mumbai - 400 102. • Tele/fax.: 022 - 2678 7421

Email : [fluid.seals@yahoo.com](mailto:fluid.seals@yahoo.com) / [fluid.seals2011@gmail.com](mailto:fluid.seals2011@gmail.com)

Website : [www.fluidsealsindia.com](http://www.fluidsealsindia.com)