

Seal Type ZR300/51U/P IMS - Slurry Seal for Non-Metallic Pump

PRODUCT DESCRIPTION

Designed to handle abrasive practical up to 30% by weight. Specially designed Back plate of pump and Impeller in this particular seal type ZR300/51U/P which gives better seal life and performance. Hydraulically balanced faces for excellent seal reliability. Helical Pumping ring helps for better siphoning effect. Specially coated spring is located outside the process. Externally supplied barrier fluid helps to lubricate the seal faces from atmospheric side of mechanical seal.

DESIGN FEATURES

Slurry seal. Double seal for Non metallic pump. Standardized modular design. Inside Mounted

MATERIALS

Seal Ring Faces : SiC and Carbon
 Seat Faces : SiC
 Elastomer : Viton, TTV, FEP and FFKM
 MOC : SS 316, PVDF – CHANGE OF MOC ON REQUEST

OPERATING CAPABILITIES

Shaft Dia. : 20mm to 80mm
 Pressure : Up to 8 bar
 Temperature: Up to 120°C
 Speed : 3000 r.p.m.

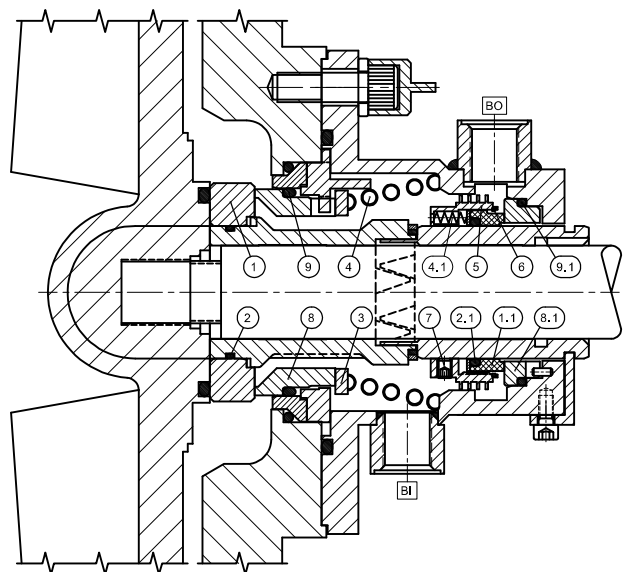

Part No.	Description	Part No.	Description
1	Seal Ring	5	Spring Holder
1.1	Seal Ring	6	Snap Ring
2	O-Ring	7	Set Screw
2.1	O-Ring	8	Seat
3	Thrust Ring	8.1	Seat
4	Spring	9	O-Ring
4.1	Spring	9.1	O-Ring

APPLICATIONS

Specially developed for steel plants on CRM (Cold Rolling Mill) in acid circulation pumps and filter press for PP, PVDF & PFA Lining Pump.