

INSTALLATION AND USER INSTRUCTIONS

Industrial Applications

HydroFLOW *i Range*

45i, 60i, 100i, 120i, 160i



Paso del Norte Industrial Supply

313 Morning Star Dr.

Santa Teresa, NM 88008 USA

Tel: +001 (915) 630-3718

www.hydroconditioners.com pasodelnorteindustrial@gmail.com

Issue E Document No: IIIR-01, USDA Certifications 2746, 2790



Electrical Specifications

Input Voltage 87-240V AC

Input Frequency 47-63 Hz

Material Specifications

Main unit: Anodised Aluminium
End plates: UL V-0 rated polycarbonate

Water and Dust Protection

IP Rating: IP68 IEC 60529

Built-in EMI Filter

Meets: FCC 20780 Class B
VDE 0871 Level A

Safety

Europe and Worldwide:
IEC51010-190+A1:92 +A2:95 ~EN61010
Tested accorded to CENELEC National Requirements
USA: UL3101-1
Canada: CSA22.2 No:1010.1-92

Over-voltage (Transients) 10 to 20% above nominal

Environmental Specifications

Installation category:
Cat II; Altitude: <2000 Mtrs (6562'); Operating Temperature: -20 to + 50° C (-4 to 122°F);
Maximum relative humidity; Max 80% up to 31°C (87° F) decreasing linearly to 50% RH at 40° C (104° F)

Overload Protection Continuous short or open circuit on all outputs.

Insulation Basic insulation with the metal enclosure bonded to earth

Servicing

No user repairable parts are fitted. Repair must be undertaken by an authorised repair centre.

Panel Indicators

The PSU is fitted with LED indicator lights. The Green LED indicates that the power is on, and the Red indicates that a signal is being transmitted.

CSA Certification and CB Test Certificate

In accordance with the International (IEC) and UL/CSA standards listed above.



Manufactured to BSEN9002



Electrical Specifications

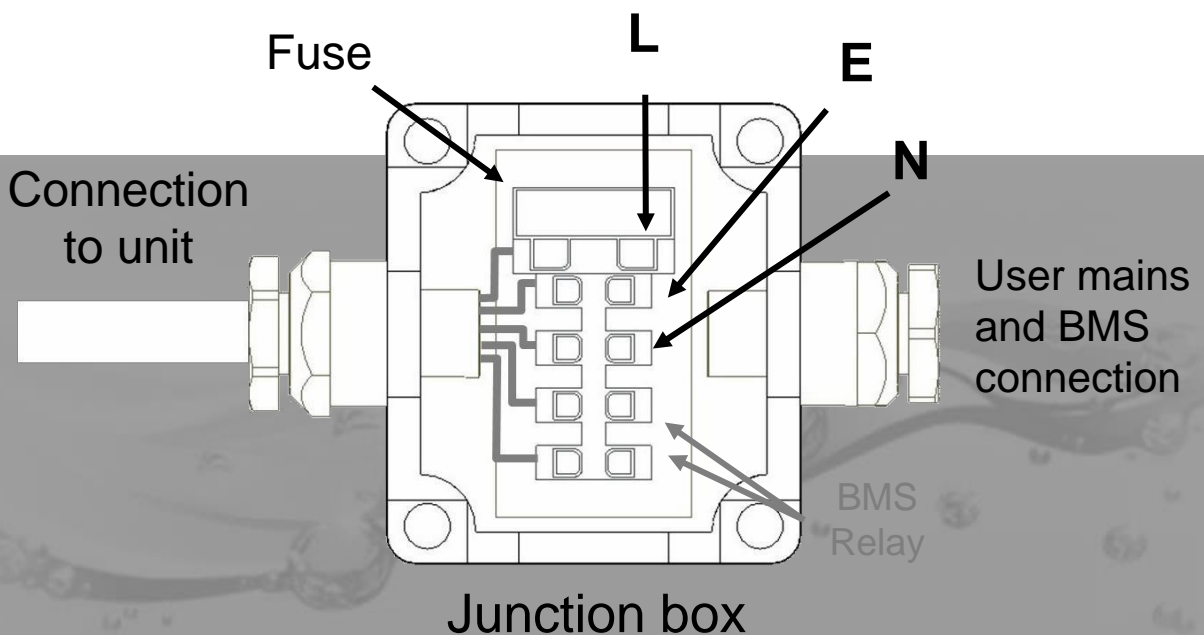
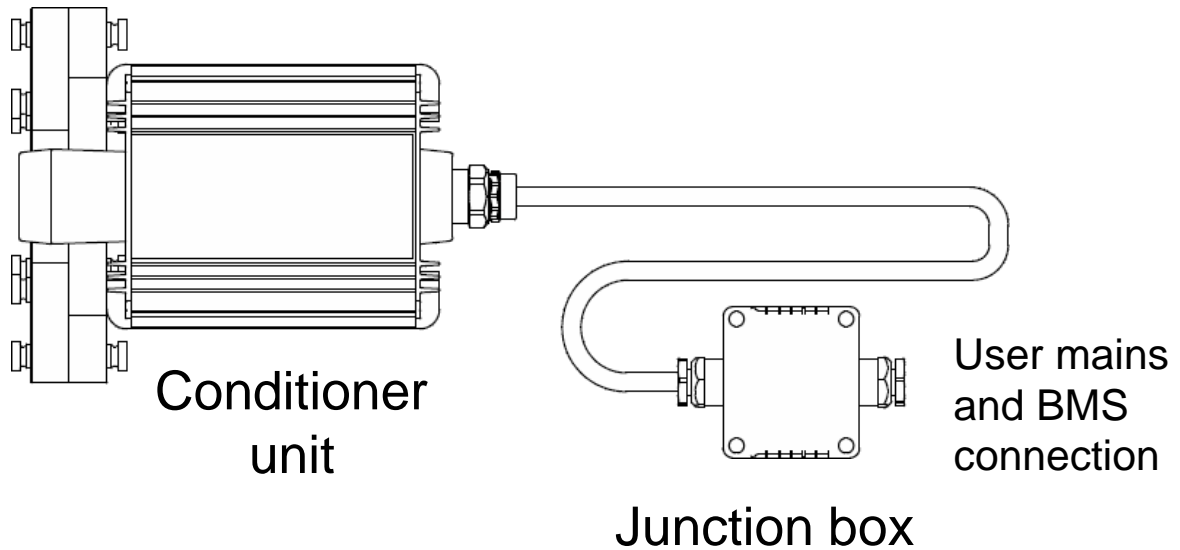

Remote Monitoring Facility

A volt free normally open contact closure is provided by the unit connection with a BMS (business Management System) computer, to monitor that the unit is operating correctly. Connection to the BMS output is made via the junction box. A suitable 5 core approved cable must be used in order to make connection to the mains input and the BMS output.

Electrical Connection

The user must connect the electrical supply to the junction box in accordance with the on-site ruling safety legislation at the time of installation. This is the sole responsibility of the user and the site safety officer must be consulted before installation is undertaken.

Electrical Specifications



Mechanical Details

The i Range water conditioner is specifically designed to combat limescale in commercial and/or industrial applications by clustering mineral ions, to enhance filtration by flocculating particles and to eliminate biofouling. i Range units are most commonly used on heat exchangers and plumbing systems.

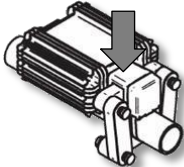
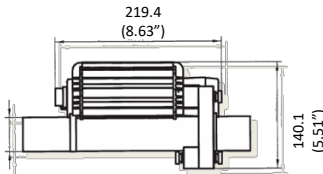
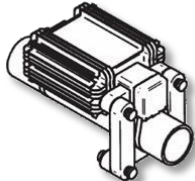
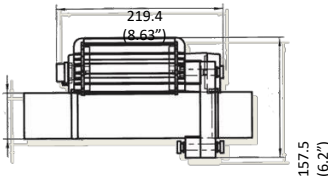
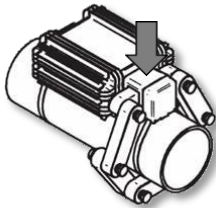
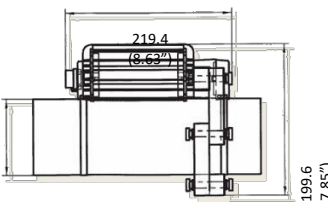
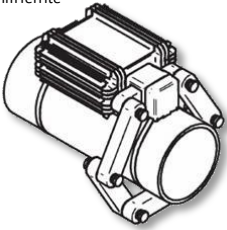
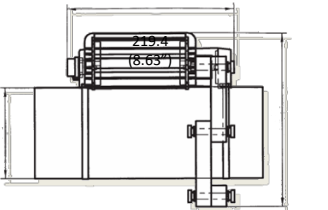
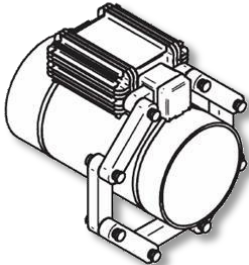
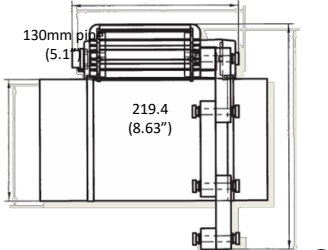
Model	Ferrite Arrangement	Dimensions mm (inches)	Ferrites	Total Weight kg (lbs)
45i	 <p>Arrow indicates longer 126mm ferrite</p>	 <p>45mm pipe (1.7")</p>	3 x 109mm (4.25") 1 x 126mm (5.0")	4.0 (8.8)
60i		 <p>60mm pipe (2.3")</p>	1 x 126mm (5.0")	4.2 (9.2)
100i	 <p>Arrow indicates longer 126mm ferrite</p>	 <p>108mm pipe (4.2")</p>	5 x 109mm (4.25") 1 x 126mm (5.0")	4.4 (9.7)
120i		 <p>130mm pipe (5.1")</p>	6 x 126mm (5.0")	4.6 (10.1)
160i		 <p>200mm pipe (7.8")</p>	8 x 126mm (5.0")	5.8 (12.8)

Mechanical Details

- All units draw less than 1 amp of current at 120V AC
- Listed weights include: Transducer unit, power supply, ferrites, cables and mounting hardware.



Assembly

DO NOT POWER UP UNIT WITHOUT FERRITES CONNECTED. ALL FERRITES SUPPLIED MUST BE CONNECTED TO TRANSDUCER.

1. Secure the transducer unit firmly on the pipe using the two steel bands. Pass the bands through the slots in both end caps, pass around the pipe and secure using screw locks (see Fig 1).
2. Insert the two hexagon nuts into the holes in the end plate, next to the ferrite holding cage (see Fig 1). If installing on a vertical pipe, place the unit with the ferrite cage upwards to ease fitting of hexagon nuts.
3. The transducer unit is supplied with at least one **long** ferrite bar. Insert this through the holding cage until the holes line up with the hexagon nuts (see Fig. 1). Take a second ferrite and insert a plastic bolt through the holes in both ferrite bars and loosely screw into hexagon nut. Assemble **all** the other ferrites around the pipe (see Fig. 2) and loosely secure with thumb nuts and bolts, making the final connection into the other hexagon nut. Tighten all nuts and bolts until hand tight. **Do not over tighten as ferrites are fragile.**
4. In accordance with local code and regulations, connect the junction box (Fig 3) to the electrical power supply (87V-240V AC).
5. Energize the electrical power supply and ensure that the Red and Green LED lights on the unit are glowing brightly.

Remote Monitoring

Remote monitoring is available for use with Business Management Systems (BMS). This is connected via the junction box. For additional information please contact an authorized representative.

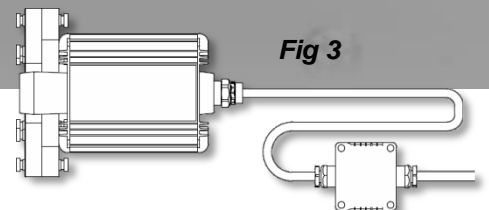
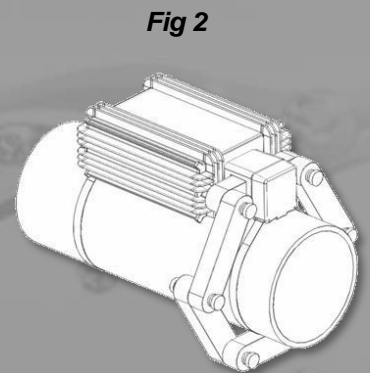
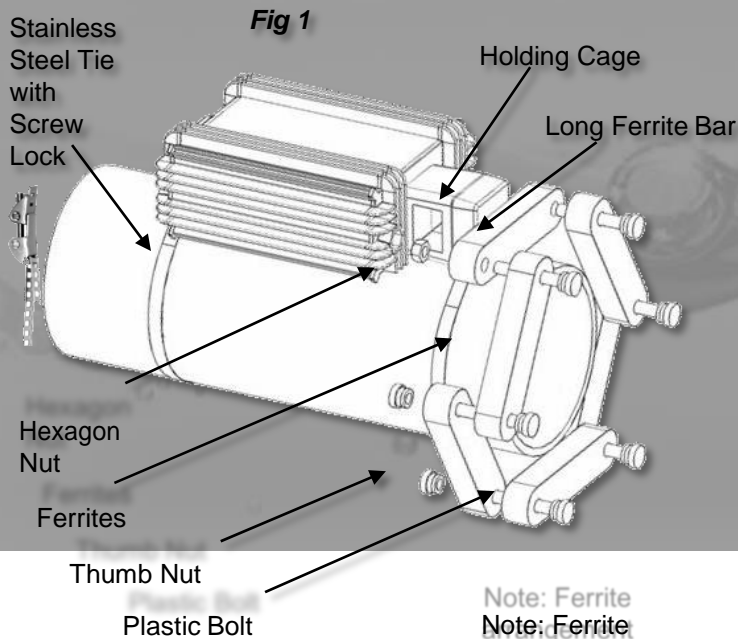

Note: Ferrite arrangement depends on unit



WARNING

The system must be used as specified. Failure to do so will prevent correct operation of device and may impair safety.

Location Criteria

The i range unit can provide a range of benefits, including protection against limescale, treatment of biofouling, and flocculation of particles. The most effective location for the unit depends on the result desired.

- For protection against Limescale due to heating, the unit should be fitted on the cold feed to where the water is heated.
- For protection against limescale, the unit should be fitted after any pumps or filters as these can degrade the conditioning effect.
- To enhance flocculation or kill bacteria, the ideal location is before the pump feeding a filter.

Location Criteria: Electrical Loops

An electrical loop is created whenever an electrical connection is made from one side of the ferrite loop to the other, e.g. by metal supports, wiring or pipework. A loop will prevent the unit from operating correctly.

This problem can be solved by moving the unit outside the electrical loop. If this is not possible, the metal support brackets can be electrically insulated. Installing the unit on a section of plastic pipe eliminates the possibility of an electrical loop.

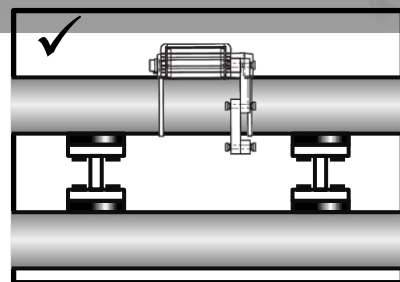
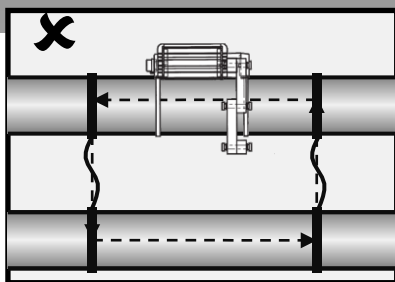
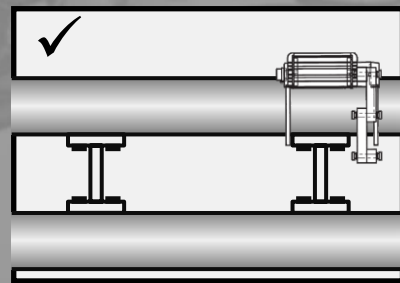
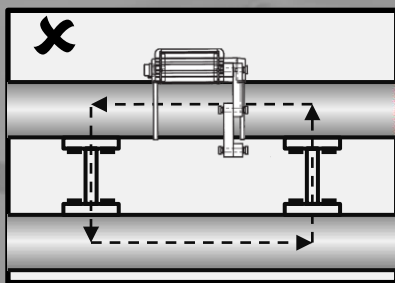

If you are unsure of any details of fitting or installation, please contact Paso del Norte for technical support.