

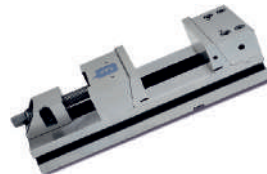

ENGEETECH ENGINEERINGS

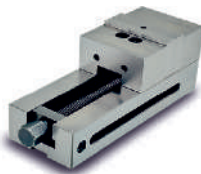

www.engeetechengineerings.com
Engeetech - Precision. Durability. Excellence

Introduction



Incorporated in the year 2010, we, “Engeetech Engineerings”, are a renowned manufacturer and Supplier of Steel Metals Products. We introduce ourselves as one of the leading companies of India involved in the field of Designing, Development and Manufacturing of Casting, Forging, Machined & Industrial, Applications. Our client base spread across the spectrum is a veritable who’s who of Indian Automotive & Engineerings Industry.

The Engeetech Machine Vise is an essential tool for precision machining, offering robust construction and high accuracy for a variety of milling, drilling, and grinding applications. Designed with professional machinists in mind, This vise features precision-ground surfaces, a high clamping force, and adjustable jaw plates to ensure reliable and versatile workholding. Available in multiple sizes and configurations, including options with Telescopic Cover, The Engeetech Machine Vise enhances machining efficiency and accuracy, Making it a valuable addition to any machine shop.

ENGEETECH SELF CENTERING MACHINE VISES

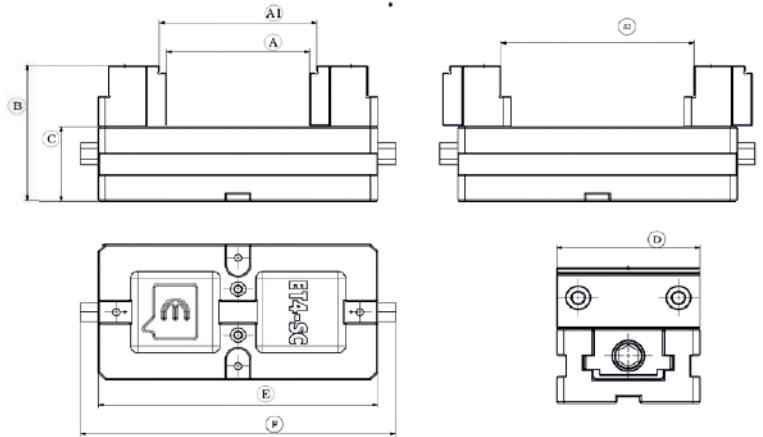

Construction:

- High stress tensile stress Relieved quality casting, precision ground hardened and tempered bed & jaw plate. Complete with Handle
- Forged Still body to resist high impact load during machining.

Technical Parameter:

- Suitable for Heavy duty cutting.
- Hardened Bad Grounded
- High durability & high precision.
- Tolerance : 0.02 Overall
- Lift proof : press down design.
- Hardness of Jaws 45-50 HRC
- ACCURACY WITHIN 0.02mm.

Application:

Self centering vise is a powerful workholding device that helps improve machining precision and repeatability. They feature two jaws that move in equal and opposite directions, so they automatically adjust the workpiece to the center of the vise - making it ideal for drilling, tapping, boring and finishing applications on CNC machines

Self-centering vises are also designed to be easy to operate, so they can help you increase efficiency and productivity in your workshop. For example, some models are designed with a push button for quick, easy jaw adjustment and release. Others have a ratchet handle for fast, precise jaw clamping.

Features:

- Vise bodies are constructed of close grained, high tensile, seasoned ductile iron castings
- Hardened Bad Grounded.
- ACCURACY WITHIN 0.02mm.

- STANDARD ACCESSORIES
- 1 Work Stopper
- 1 Ajdustable Handle

Order No. & Dimension (mm)

Model No.	A	A2	B	C	D	E	F	G	H	MAX Clamp Force (kgf)	G.W. (KGS)	CODE NO.
ET-SC	40	140	100	55	100	195	220	18	N/A	2000	8	ET-SC

ENGEETECH STANDARD VISES

4A, 6A, 8A, 10A & 12A

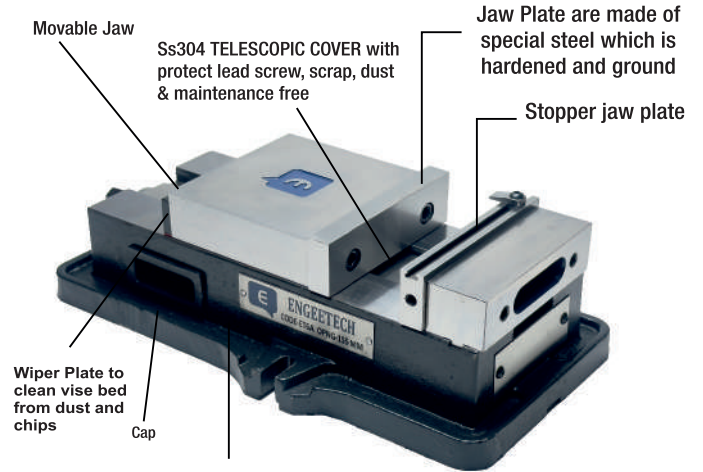
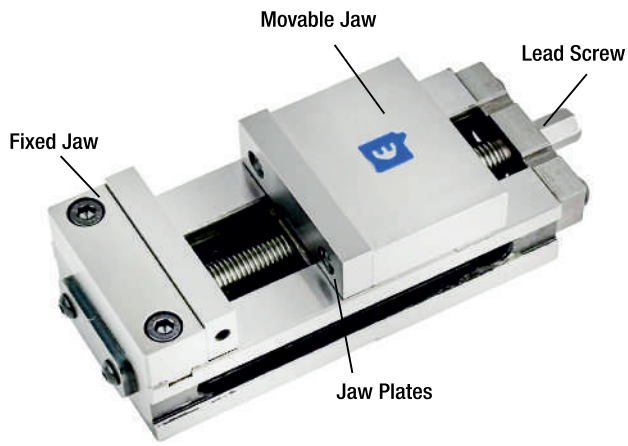

Body is made of high quality ductile iron , which resists deflection or bending, and its sliding surface flame hardened and ground

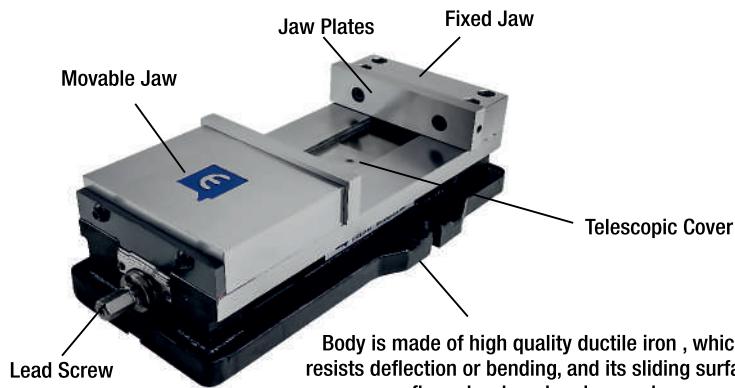

Body is made of high quality ductile iron , which resists deflection or bending, and its sliding surface flame hardened and ground

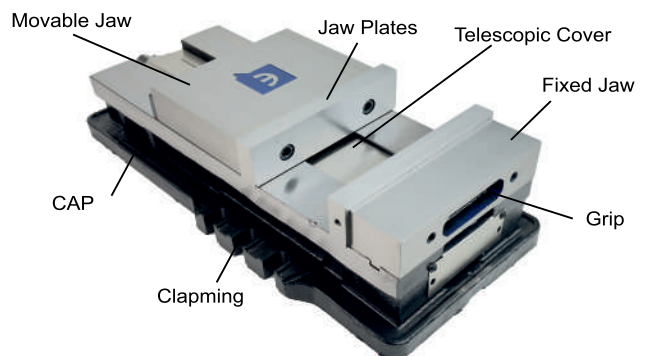
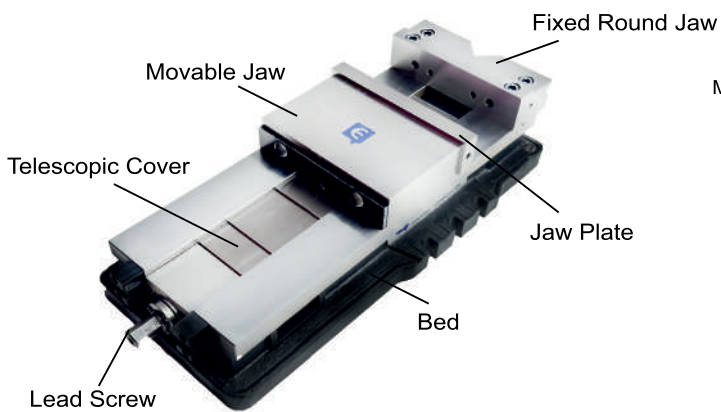

ENGEETECH STANDARD VISE 4A, 6A, 8A, 10A & 12A

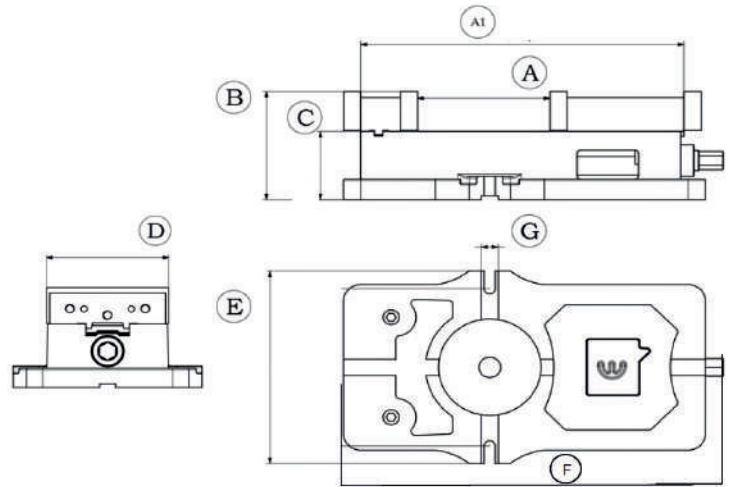

Application

Drilling: When drilling holes into workpieces, a Standard machine vise can securely hold the piece in place, preventing movement or misalignment during drilling.

This ensures precise hole placement and depth

Milling: Standard machine vises are often used in milling machines to hold workpieces securely while milling operations such as drilling, cutting, or shaping are performed. They provide stability and precision, ensuring accurate machining.

Prototyping: In prototyping or small-scale production environments, Standard vises are invaluable for holding workpieces securely during machining operations, allowing for the creation of precise prototypes or small batches of parts.

Technical Parameter

- Suitable for Heavy duty cutting.
- Hardened Bad Graunded.
- High durability & high precision.
- Tolerance : 0.02 Overall
- Lift proof : press down design.
- Two setting positions of the jaw plates are available, widening the jaw plates opening.
- ACCURACY WITHIN 0.02mm.
- Unique Technology with SS304 Telescope cover to prevent lead screw Routine maintenance and rust preventive

Construction

- High stress tensile stress Relieved quality casting,
- precision ground hardened and tempered bed & jaw plate
- Complete with Handle
- Ductile Iron Body to resist high impact load

Features

- Vise bodies are constructed of close grained, high tensile, ductile iron castings
- Hardened Bad.
- Hardness of Jaws 45-50 HRC
- STANDARD MACHINE VISE 6" JAW OPENED 155mm
- ACCURACY WITHIN 0.02mm.

Model No.	A	A1	B	C	D	E	F	G	MAX Clamp Force (kgf)	G.W. (KGS)	CODE NO.
ET 4A	100	NA	80	50	100	140	260	13	1500	9	ET 4A
ET 6A	150	375	135	85	155	240	445	18	2500	32	ET 6A
ET 8A	200	465	147	94	210	272	553	18	3500	45	ET 8A
ET 10A	250	520	147	94	210	272	595	18	3500	55	ET 10A
ET 12A	300	480	147	94	210	258	595	18	4000	60	ET 12A

ENGEETECH COMPACT VISES 4C, 6C, 8C, 10C & 12C

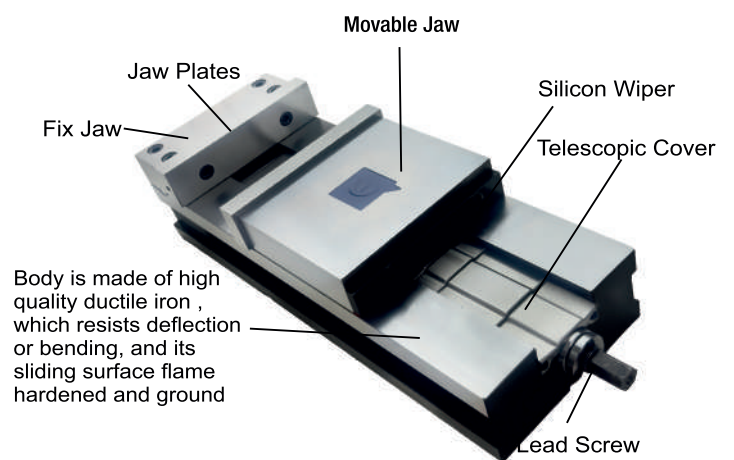
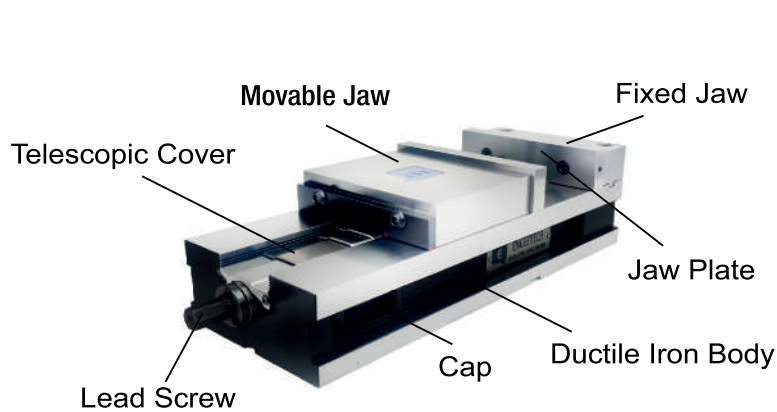
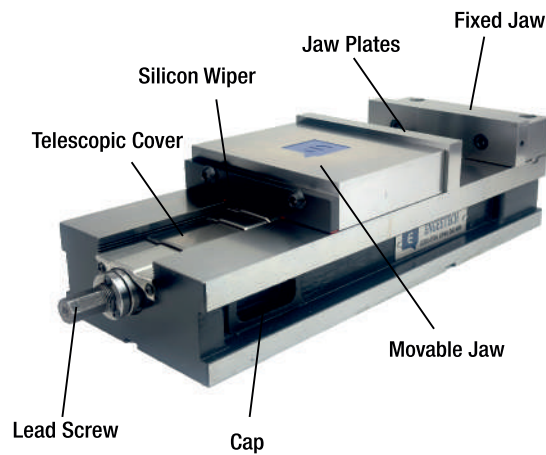
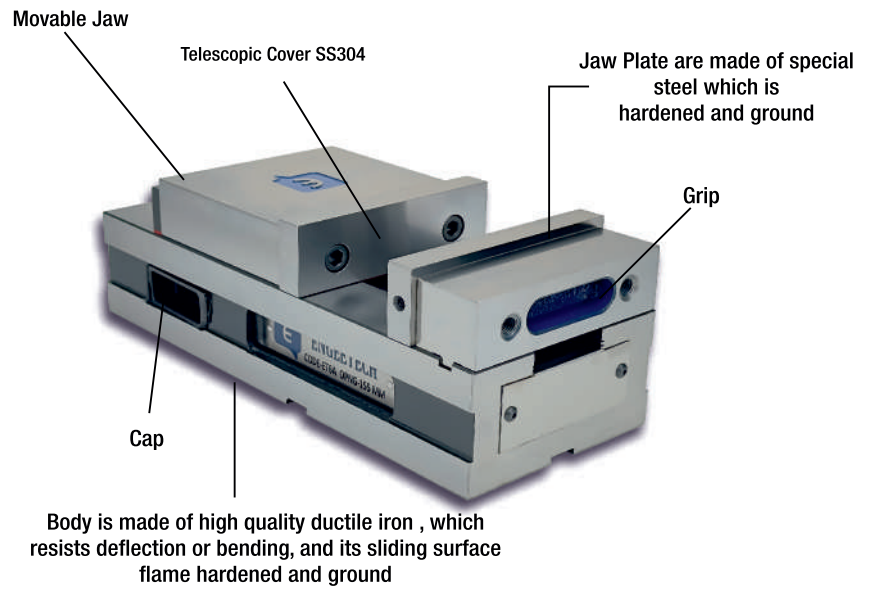
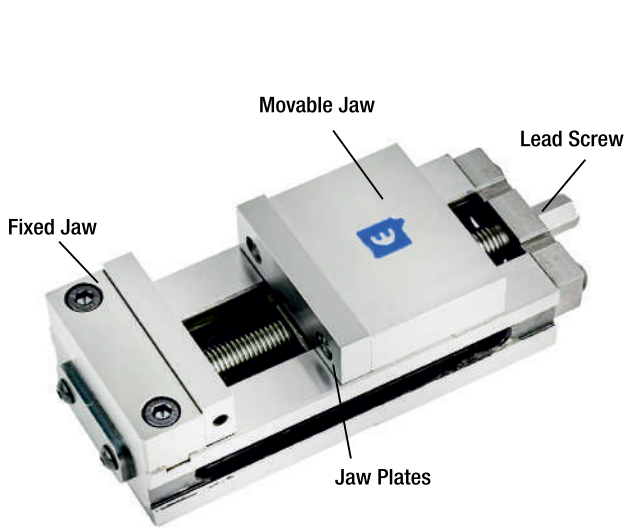

ENGEETECH STANDARD VISE

6C, 8C, 10C & 12C

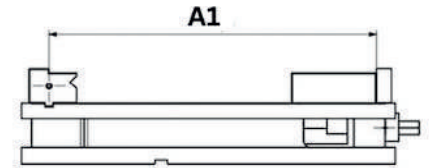
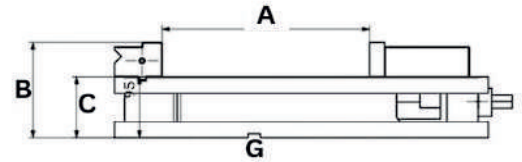
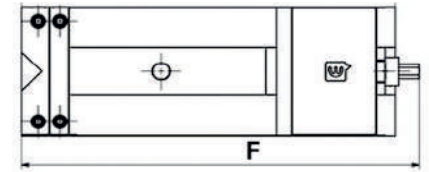
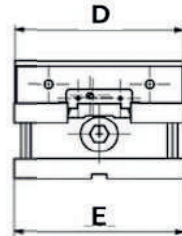

Construction:

- High stress tensile stress Relieved quality casting, precision ground hardened and tempered bed & jaw plate.
- Complete with Handle.
- Ductile Iron Body to resist high impact load during machining.

Application:

- **MILLING:** Compact 12 inch machine vises are often used in milling machines to hold workpieces securely while milling operations such as drilling, cutting, or shaping are performed. They provide stability and precision, ensuring accurate machining.
- **DRILLING:** When drilling holes into workpieces, a Compact machine vise can securely hold the piece in place, preventing movement or misalignment during drilling. This ensures precise hole placement and depth
- **GRINDING:** In precision grinding operations, a Compact vise can be used to securely clamp small workpieces for precise grinding and finishing operations.
- **PROTOTYPE:** In prototyping or small-scale production environments, Compact vises are invaluable for holding workpieces securely during machining operations, allowing for the creation of precise prototypes or small batches of parts.

Technical Parameter

- Suitable for Heavy duty cutting.
- Hardened Bad Grounded
- Tolerance : 0.02 Overall
- Lift proof : press down design.
- Hardness of Jaws 45-50 HRC
- Unique Technology with SS304 Telescope cover to prevent lead screw maintenance and rust preventive.
- Two setting positions of the jaw plates are available, widening the jaw plates opening.
- ACCURACY WITHIN 0.02mm.

Features:

- Vise bodies are constructed of close grained high tensile, seasoned ductile iron castings
- Hardened Bad Grounded.
- ACCURACY WITHIN 0.02mm.

Model No.	A	A1	B	C	D	E	F	G	MAX Clamp Force (kgf)	G.W. (KGS)	CODE NO.
ET 4C	100	NA	80	50	100	100	260	240	1500	8	ET 4C
ET 6C	150	375	130	80	150	150	420	18	2500	30	ET 6C
ET 8C	200	465	149	96	200	202	510	18	3500	42	ET 8C
ET 10C	250	520	149	96	200	202	575	18	3500	55	ET 10C
ET 12C	300	480	148	95	200	202	585	18	4000	60	ET 12C

Engeetech Precision Modular PULLDOWN MACHINE VISES 8", 12" and Split Vise

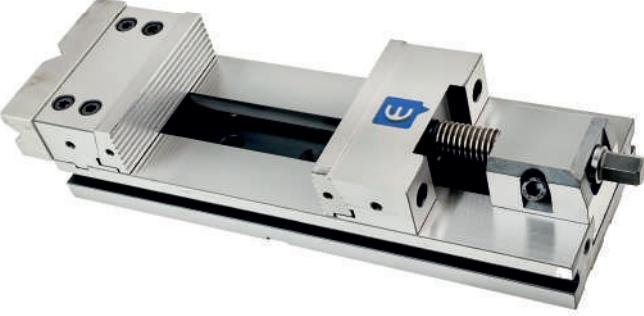
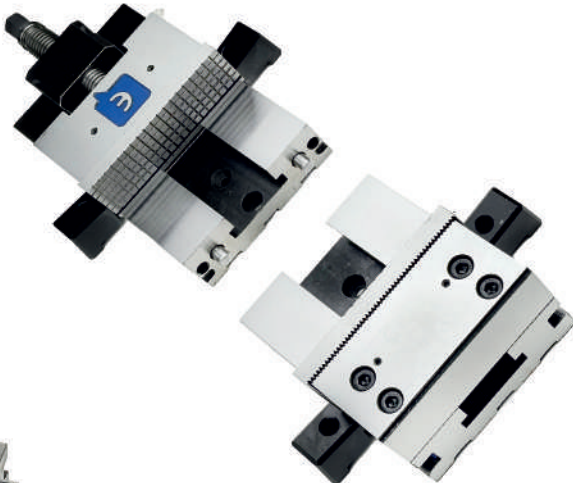
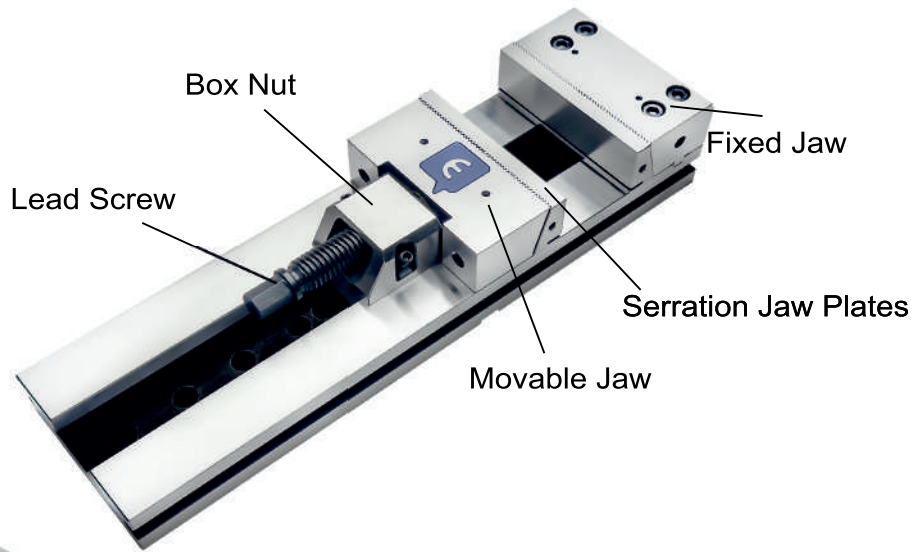

Engeetech Precision Modular PULLDOWN MACHINE VISES 8", 12" and Split Vise

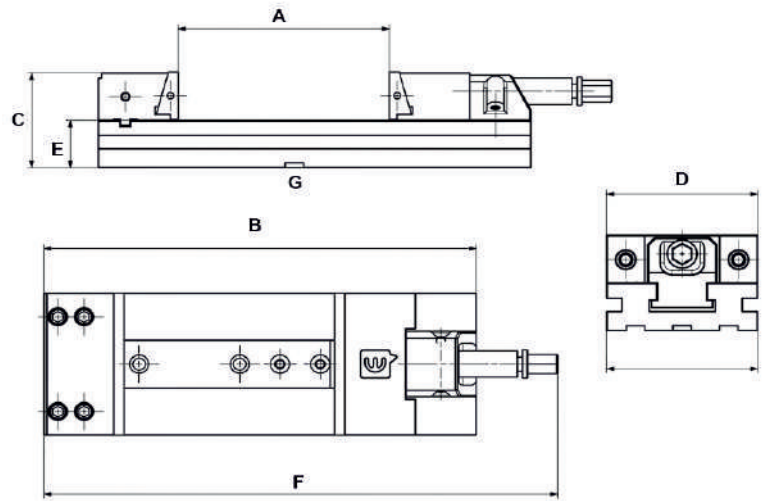

Features

Forged Material

- **Grain Structure:** Forging refines the grain structure of the metal, enhancing its strength and toughness.
- **Fatigue Resistance:** Components made from forged alloy steel have better fatigue resistance, which means they can endure repeated loading and unloading cycles.
- **Consistency:** Forging eliminates internal voids and porosity, resulting in more uniform and reliable parts.
- mm
- **ACCURACY** Within 0.02 mm
- **Lift proof :** press down design

Application

- **CNC Machining:** Suitable for high-precision CNC machining operations where stability and accuracy are crucial.
- **Metalworking:** Ideal for various metalworking tasks such as milling, drilling, and grinding.
- **Heavy-Duty Applications:** Used in environments where the vise is subjected to high forces and repetitive use.
- **High Clamping Force:** The vise can generate and withstand high clamping forces due to its strong material properties.
- **Durability:** Alloy steel construction and forging make the

Case Carburizing

Carbon Enrichment: The surface of the steel is exposed to a carbon-rich environment at high temperatures, which allows carbon to diffuse into the surface.

Hardening: The enriched surface layer is then quenched, resulting in a hard, wear-resistant outer layer with a softer, tougher interior.

Wear Resistance: The hard surface resists wear and abrasion, extending the life of the vise.

Alloy Steel Construction

Increased Strength: Alloy steel is stronger than standard carbon steel, allowing the vise to withstand higher clamping forces without deforming.

Improved Toughness: The material is more resistant to impacts and shocks, making it durable under heavy machining loads.

Enhanced Wear Resistance: Alloy steel has better wear resistance, which is crucial for a tool that will undergo constant use and pressure.

- Special Alloy Steel Case Carburizing 50 +- 5 HRC

Model No.	A	B	C	C1	D	D1	E	F	G	H	MAX Clamp Force (kgf)	G.W. (KGS)	CODE NO.
ET-8PM	225	430	100	N/A	150	N/A	50	511	18	N/A	4500	33	ET-8PM
ET 12PM	325	530	100	N/A	150	N/A	50	608	18	N/A	4500	38	ET 12PM
ET SPL	Limit Less	335	100	N/A	150	N/A	50	365	18	N/A	4500	38	ET SPL

ENGEETECH 4" SURFACE GRINDING MACHINE VISE

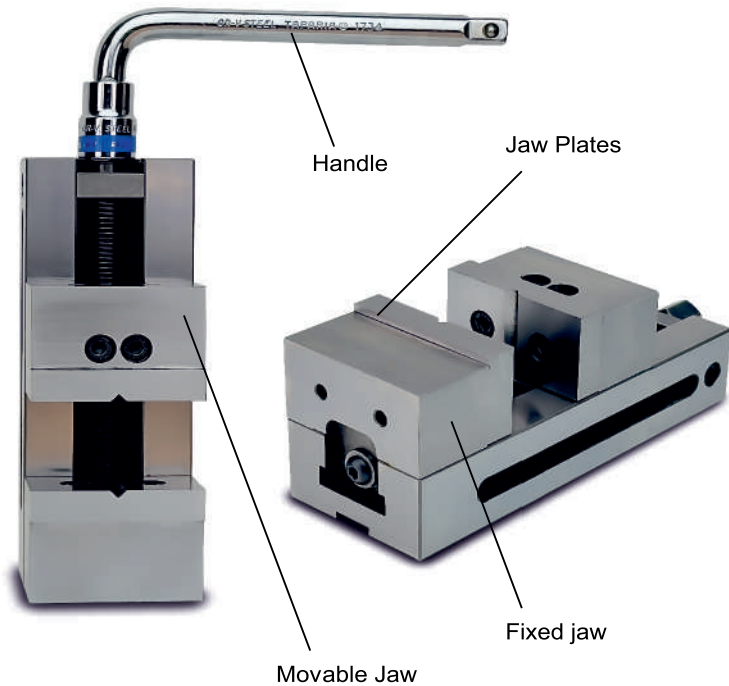

Stability: Provides a stable and secure hold on the workpiece, reducing vibrations and movement during the grinding process.

Precision: Ensures high precision in grinding operations, which is critical for achieving tight tolerances and excellent surface finishes.

Versatility: Can be used for a wide range of applications, from flat surface grinding to complex angle grinding and finishing.

Efficiency: Increases efficiency by allowing multiple parts to be ground simultaneously and by reducing setup times with repeatable positioning.

Safety: Enhances safety by securely holding the workpiece, minimizing the risk of movement or slippage during grinding.

Features

- Vise bodies are constructed of close grained, high tensile, ductile iron castings
- Hardness of Jaws 45-50 HRC
- MINI MACHINE VISE 4" JAW OPENED 105mm
- ACCURACY WITHIN 0.01 -0.02mm.
- Special ductile iron, hardened with 180-220 BHN

Application

- Surface Grinding & Engraving Application

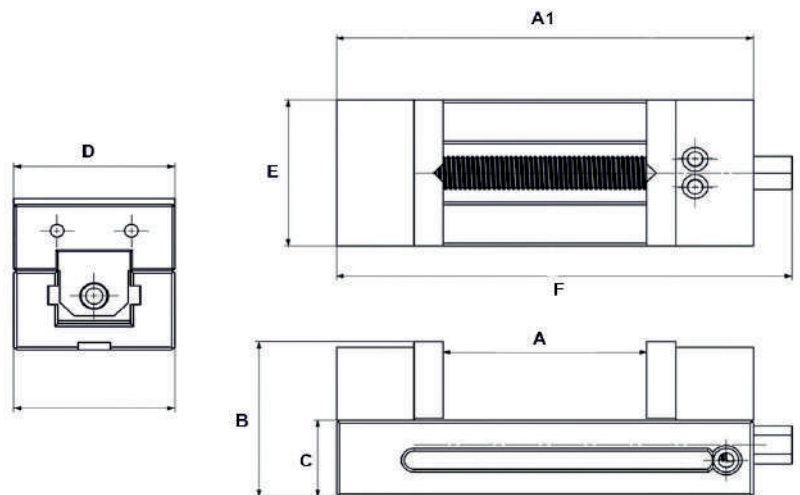

Order No. & Dimension (mm)

- STANDARD ACCESSORIES
- 1 Work Stopper
- 1 Adjustable Handle

Model No.	A	A1	B	C	D	E	F	G	H	MAX Clamp Force (kgf)	G.W. (KGS)	CODE NO.
ET-4A	105	205	85	42	80	80	235	N/A	N/A	800	7	ET-4A

ENGEETECH CHUCK VISE 6"

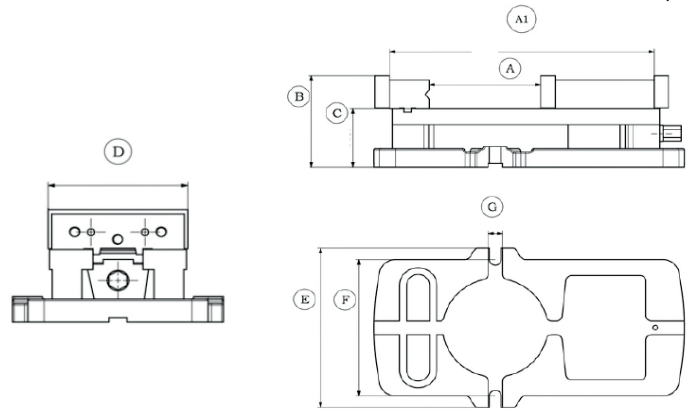
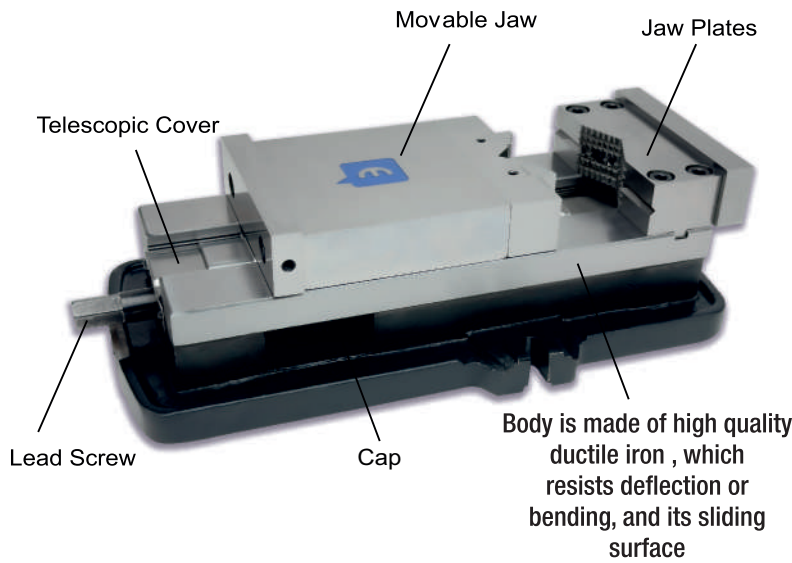

Features

- OD clamping devices are designed to clamp onto the outer diameter (OD) of the workpiece or tool. OD Clamping is common with machining chucks used application such as mil
- Locking chucks can be locked or set to provide holding force, even when the actuation mechanism is removed.
- Through-hole chucks have a center through-hole for chucking or gripping long sections of stock, pipe etc.
- Manual chucks are adjusted and tightened by the operator's hands.
- Special ductile iron, hardened and ground
- Hardness of Jaws 50+ 5 HRC
- Chuck Jaw Machine Vise 6" Jaw Opened 155 mm
- Accuracy within 0.01mm to 0.02 mm
- Lift proof: Press down design

Technical Parameter

- Suitable for heavy duty cutting
- Hardened Bad Grounded
- High durability & High precision
- Tolerance: 0.02 Overall
- Lift Proof: Press down design
- Hardness of Jaws 50+ 5HRC
- Unique technology with SS304 telescope cover to prevent lead screw maintenance and rust preventive
- Two setting positions of the jaw plates are available, widening the jaw plates opening
- Accuracy within 0.02 mm.

Application

- Grinding Machines
- Heavy cutting processes by, milling Drilling machines and planers
- Metallic mold machining

- STANDARD ACCESSORIES
- 1 Work Stopper
- 1 Adjustable Handle

Order No. & Dimension (mm)

Model No.	A	A1	B	C	D	E	F	G	MAX Clamp Force (kgf)	G.W. (KGS)	CODE NO.
ET 6C	155	375	130	80	155	150	420	18	2500	30	ET 6C

ENGEETECH MACHINE VISE ACCESSORIES

Products



ANGULAR JAW PLATE

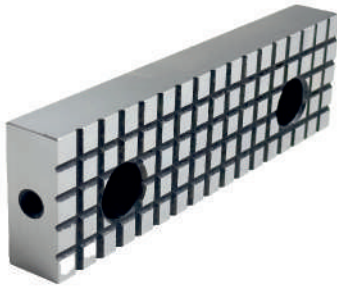

DIAMOND JAW PLATES

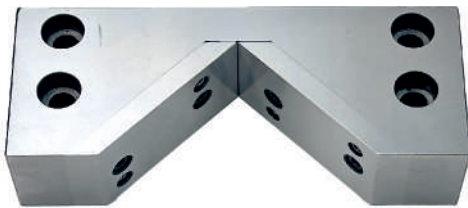

ROUND JAW



STOPPER JAW PLATE

Description

Machine vises are essential tools in machining and manufacturing industries, where precision and stability are paramount. To enhance the functionality of machine vises, advanced angular jaw plates have been developed, providing a significant upgrade over traditional flat jaw plates. These advanced components are designed to handle complex workpieces with irregular shapes, offering improved grip, versatility, and accuracy during machining operations. Angular jaw plates are specialized components that attach to the jaws of a machine vise, replacing the standard flat plates. These plates are designed with angled surfaces, which can vary in degree depending on the specific application. The angular design allows for better clamping of irregularly shaped or angular workpieces, ensuring that they are held securely and at the correct orientation during machining.

Rough jaw plates are engineered with a textured or serrated surface, which increases the friction between the jaw plates and the workpiece. This design is particularly effective for gripping materials that are rough, uneven, or prone to slipping under pressure, such as castings, forgings, and other raw materials. The serrations or raised patterns on the surface of the jaw plates bite into the workpiece, providing a more secure hold than smooth or flat jaw plates. One of the key advantages of rough jaw plates is their ability to maintain a strong grip on challenging workpieces without applying excessive clamping force. In some cases, applying too much force can damage the workpiece or cause it to deform. Rough jaw plates, however, achieve a firm grip through their textured surface, reducing the need for high clamping pressure and minimizing the risk of workpiece damage.

Round jaw plates are specialized attachments designed to replace the standard flat jaws of a machine vise. These plates feature a concave, circular design that allows them to grip cylindrical or round objects more effectively than traditional flat jaws. The curvature of the round jaw plates matches the contour of the workpiece, distributing the clamping force evenly across its surface.

One of the key advantages of round jaw plates is their ability to securely hold round or cylindrical objects, such as pipes, rods, and shafts, which are challenging to clamp with flat jaws. Flat jaws often exert pressure unevenly on these shapes, leading to slippage or deformation of the workpiece. Round jaw plates, however, provide a more uniform grip, reducing the risk of movement during machining and ensuring greater accuracy.

Stopper jaw plates are designed to attach to the jaws of a machine vise, introducing a built-in stopper or reference edge against which the workpiece can be positioned. This stopper serves as a fixed point of contact, ensuring that the workpiece is consistently aligned in the same position each time it is clamped. The design of these jaw plates can vary, with some featuring adjustable stoppers to accommodate different workpiece sizes, while others may have fixed stoppers designed for specific applications.

The primary function of a stopper jaw plate is to provide a reliable and repeatable reference point, which is especially important in precision machining operations where even minor deviations in workpiece positioning can lead to

ENGEETECH MACHINE VISE ACCESSORIES

Products



OPEN AND CLOSE HANDLE



ANGULAR JAW PLATE



STOPPER JAW PLATE

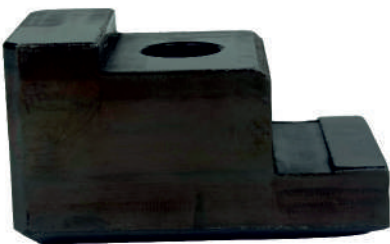

VISE CLAMP



LEAD SCREW

Description

Open the Vise: Use the handle to open the jaws of the vise wide enough to accommodate your workpiece.

Place the Workpiece: Carefully place your workpiece between the jaws of the vise, ensuring it is positioned securely and evenly.

Close the Vise: Use the vise handle to tighten the jaws around the workpiece. Apply enough pressure to hold the workpiece firmly in place, but be careful not to over-tighten and damage the workpiece.

Perform the Operation: With the workpiece securely held in the vise, you can now perform whatever machining or other operations you need to do.

Release the Workpiece: Once you're finished with the operation, loosen the vise jaws using the handle and remove your workpiece.

Opening and Closing: The jaws of the vise can be opened or closed using a handle or a crank. This allows for accommodating various sizes of workpieces.
Adjustability: Some vises come with features for adjusting the angle or position of the jaws to accommodate different machining requirements.

Adjust the Vise: Loosen the vise's locking mechanism or adjustment screws to allow the jaws to be moved. Use a protractor or angle gauge to set the desired angle accurately.

Secure the Workpiece: Once you have set the vise to the desired angle, carefully place your workpiece between the jaws of the vise. Make sure it is positioned securely and evenly.

Tighten the Vise: Use the vise handle to tighten the jaws around the workpiece. Apply enough pressure to securely hold the workpiece in place at the desired angle.

Perform the Machining Operation: With the workpiece securely held in the vise at the desired angle, you can now perform the machining operation, such as milling, drilling, or grinding.

Prepare the Machine Table: Ensure that the machine table has T-slots that match the T-nuts on the bottom of the vise. Clean the T-slots and make sure they are free of debris.

Insert T-nuts: Place T-nuts into the T-slots on the machine table. The number of T-nuts needed depends on the size and configuration of the vise.

Position the Vise: Position the vise on the machine table so that the T-nuts on the bottom of the vise align with the T-slots on the table.

Centering: Screw vises usually have features for centering the workpiece accurately within the vise jaws. This ensures that the workpiece is held securely and concentrically during machining operations.

Features

Unique features for the 8-inch, 10-inch and 12-inch clamping vise:

- 1. Ductile Iron Body:** The vise is constructed with a durable ductile iron body, providing exceptional strength and resilience for heavy-duty use.
- 2. Hardened and Grinding Bed:** The bed is hardened and precisely ground, offering a smooth and stable surface to ensure accurate clamping.
- 3. Stainless Steel Telescopic Cover:** Featuring a stainless steel telescopic cover, the vise not only has a polished appearance but is also protected from dust and chips during machining.
- 4. 1-inch Lead Screw Alloy Steel Forged Material:** The vise includes a 1-inch lead screw made from forged alloy steel, ensuring robustness and longevity under intense pressure.
- 5. Versatile Accessories:** Available with specialized accessories like a Round Jaw for clamping round jobs up to 150 mm and an Angular Jaw for securely clamping angled work pieces, making it adaptable to a wide range of applications.
- 6. Two Setting Clamping Range:** The vise offers a versatile clamping range with two settings, accommodating different work piece sizes with ease.
- 7. Plastic Cap for Chips Protection:** A plastic cap is provided to protect against chips, ensuring the smooth operation and longevity of the vise's internal components.
- 8. Clamping Force Tested with 2500 PSI:** The vise has been rigorously tested to withstand a clamping force of up to 2500 PSI, ensuring reliable and consistent performance.
- 9. 19mm Forged Jaw Plates:** Equipped with 19mm thick forged jaw plates, the vise delivers a strong and secure grip on workpieces, facilitating precision during operations.
- 10. Accuracy Level Within 0.02 mm with CMM Report:** The vise guarantees high precision, with an accuracy level within 0.02 mm, as verified by a Coordinate Measuring Machine (CMM) report.
- 11. Affordable Spare Parts:** Spare parts are readily available at affordable prices, ensuring easy maintenance and extended service life.
- 12. 100% Made in India:** This vise is proudly manufactured in India, supporting local craftsmanship and meeting stringent quality standards.
- 13. Wiper Plate:** Removes dust and chips from the bed during operation, maintaining a clean surface for precise clamping and prolonging the vise lifespan.

Unique features for the High Precise Modular Pull-down Vise available in 6, 8, and 10-inch sizes

- 1. Steel Body with EN353 Forged Construction:** The vise features a robust steel body made from EN353 forged material, providing exceptional strength and durability.
- 2. Case Hardened with 55-60 HRC and Full Grinding:** The vise undergoes case hardening to achieve a hardness level of 55-60 HRC, followed by full grinding to ensure precision and longevity.
- 3. 28mm Lead Screw with Acme Thread:** Equipped with a 28mm lead screw featuring Acme threads, forged from alloy steel, the vise ensures smooth and reliable operation under heavy loads.
- 4. Unique Pull-down Clamping Feature:** The vise is designed with a unique feature that pulls the job down during clamping, ensuring a more secure and accurate hold.
- 5. Available in Multiple Sizes:** Offered in a 6-inch width, with opening ranges of 150 mm, 200 mm, and 300 mm, the vise also includes a Split Vise option for multiple clamping scenarios.
- 6. Clamping Force Tested with 3500 to 4000 PSI:** Rigorously tested to withstand clamping forces between 3500 to 4000 PSI, the vise guarantees reliable performance in demanding applications.
- 7. 20 mm Angular Forged Jaw Plates:** The vise is fitted with 20mm angular forged jaw plates, ensuring a strong and precise grip on the workpiece.
- 8. Accuracy Level Within 0.02 mm with CMM Report:** The vise achieves a high level of precision, with an accuracy within 0.02 mm, as verified by a Coordinate Measuring Machine (CMM) report.
- 9. Available in Serration and Fixed Jaws:** The vise is available with both serrated and fixed jaws, providing flexibility for various clamping needs.
- 10. Most Durable Vise in the Product Range:** Recognized as the most durable vise in the product line-up, it offers unmatched longevity and reliability.
- 11. Affordable Spare Parts:** Spare parts are readily available at an affordable price, ensuring easy maintenance and extended service life.

Engeetech-Products at a glance

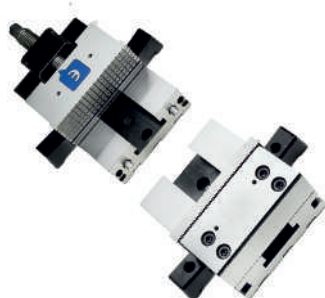
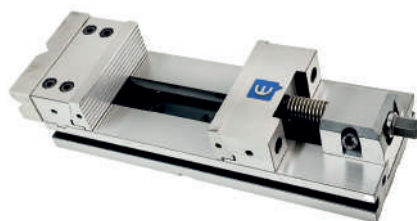
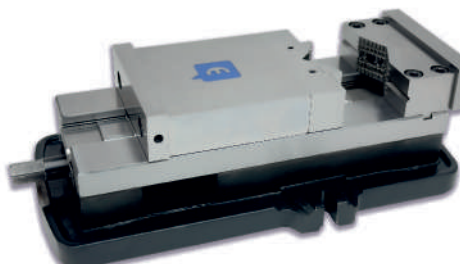
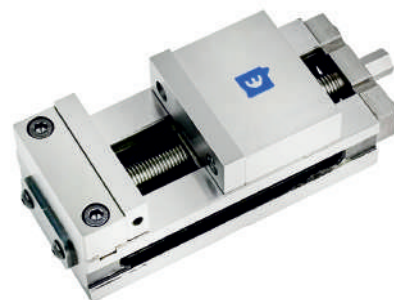
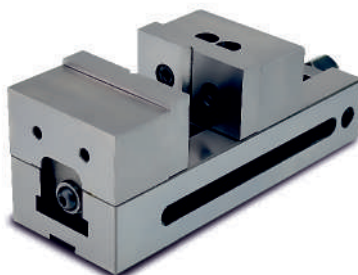
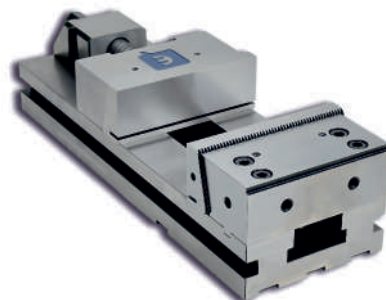
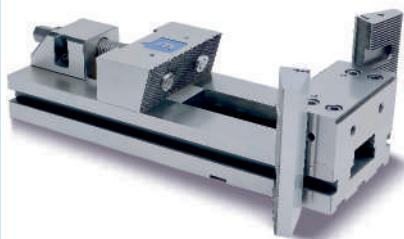



ENGEETECH ENGINEERINGS

www.engeetechengineerings.com

ENGEETECH - Precision. Durability. Excellence



For more info:

Engteech Engineerings

31-B Sector A Sanwer Road Industrial Area Indore - 452015 Madhya Pradesh - India

engeetechengineerings@gmail.com, salesengeetechengineerings@gmail.com

contact us : +917314029366 , +919826024869 , +919893026489

www.engeetechengineerings.com



ENGEETECH ENGINEERINGS

www.engeetechengineerings.com
ENGEETECH - Precision. Durability. Excellence



For more info:

Enggetech Engineerings

31-B Sector A Sanwer Road Industrial Area Indore - 452015 Madhya Pradesh - India

engeetechengineerings@gmail.com, salesengeetechengineerings@gmail.com

contact us : +917314029366 , +919826024869 , +919893026489

www.engeetechengineerings.com



ENGEETECH ENGINEERINGS



www.engeetechengineerings.com
Enggetech - Precision. Durability. Excellence

Introduction



Incorporated in the year 2010, we, "Engeetech Engineerings", are a renowned manufacturer and Supplier of Steel Metals Products. We introduce ourselves as one of the leading companies of India involved in the field of Designing, Development and Manufacturing of Casting, Forging, Machined & Industrial, Applications. Our client base spread across the spectrum is a veritable who's who of Indian Automotive & Engineerings Industry.

The Engeetech Machine Vise is an essential tool for precision machining, offering robust construction and high accuracy for a variety of milling, drilling, and grinding applications. Designed with professional machinists in mind, This vise features precision-ground surfaces, a high clamping force, and adjustable jaw plates to ensure reliable and versatile workholding. Available in multiple sizes and configurations, including options with Telescopic Cover, The Engeetech Machine Vise enhances machining efficiency and accuracy, Making it a valuable addition to any machine shop.

Engeetech-Products at a glance



Features

Unique features for the 8-inch, 10-inch and 12-inch clamping vise:

- 1. Ductile Iron Body:** The vise is constructed with a durable ductile iron body, providing exceptional strength and resilience for heavy-duty use.
- 2. Hardened and Grinding Bed:** The bed is hardened and precisely ground, offering a smooth and stable surface to ensure accurate clamping.
- 3. Stainless Steel Telescopic Cover:** Featuring a stainless steel telescopic cover, the vise not only has a polished appearance but is also protected from dust and chips during machining.
- 4. 1-inch Lead Screw Alloy Steel Forged Material:** The vise includes a 1-inch lead screw made from forged alloy steel, ensuring robustness and longevity under intense pressure.
- 5. Versatile Accessories:** Available with specialized accessories like a Round Jaw for clamping round jobs up to 150 mm and an Angular Jaw for securely clamping angled work pieces, making it adaptable to a wide range of applications.
- 6. Two Setting Clamping Range:** The vise offers a versatile clamping range with two settings, accommodating different work piece sizes with ease.
- 7. Plastic Cap for Chips Protection:** A plastic cap is provided to protect against chips, ensuring the smooth operation and longevity of the vise's internal components.
- 8. Clamping Force Tested with 2500 PSI:** The vise has been rigorously tested to withstand a clamping force of up to 2500 PSI, ensuring reliable and consistent performance.
- 9. 19mm Forged Jaw Plates:** Equipped with 19mm thick forged jaw plates, the vise delivers a strong and secure grip on workpieces, facilitating precision during operations.
- 10. Accuracy Level Within 0.02 mm with CMM Report:** The vise guarantees high precision, with an accuracy level within 0.02 mm, as verified by a Coordinate Measuring Machine (CMM) report.
- 11. Affordable Spare Parts:** Spare parts are readily available at affordable prices, ensuring easy maintenance and extended service life.
- 12. 100% Made in India:** This vise is proudly manufactured in India, supporting local craftsmanship and meeting stringent quality standards.
- 13. Wiper Plate:** Removes dust and chips from the bed during operation, maintaining a clean surface for precise clamping and prolonging the vise lifespan.

Unique features for the High Precise Modular Pull-down Vise available in 6, 8, and 10-inch sizes

- 1. Steel Body with EN353 Forged Construction:** The vise features a robust steel body made from EN353 forged material, providing exceptional strength and durability.
- 2. Case Hardened with 55-60 HRC and Full Grinding:** The vise undergoes case hardening to achieve a hardness level of 55-60 HRC, followed by full grinding to ensure precision and longevity.
- 3. 28mm Lead Screw with Acme Thread:** Equipped with a 28mm lead screw featuring Acme threads, forged from alloy steel, the vise ensures smooth and reliable operation under heavy loads.
- 4. Unique Pull-down Clamping Feature:** The vise is designed with a unique feature that pulls the job down during clamping, ensuring a more secure and accurate hold.
- 5. Available in Multiple Sizes:** Offered in a 6-inch width, with opening ranges of 150 mm, 200 mm, and 300 mm, the vise also includes a Split Vise option for multiple clamping scenarios.
- 6. Clamping Force Tested with 3500 to 4000 PSI:** Rigorously tested to withstand clamping forces between 3500 to 4000 PSI, the vise guarantees reliable performance in demanding applications.
- 7. 20 mm Angular Forged Jaw Plates:** The vise is fitted with 20mm angular forged jaw plates, ensuring a strong and precise grip on the workpiece.
- 8. Accuracy Level Within 0.02 mm with CMM Report:** The vise achieves a high level of precision, with an accuracy within 0.02 mm, as verified by a Coordinate Measuring Machine (CMM) report.
- 9. Available in Serration and Fixed Jaws:** The vise is available with both serrated and fixed jaws, providing flexibility for various clamping needs.
- 10. Most Durable Vise in the Product Range:** Recognized as the most durable vise in the product line-up, it offers unmatched longevity and reliability.
- 11. Affordable Spare Parts:** Spare parts are readily available at an affordable price, ensuring easy maintenance and extended service life.

ENGEETECH SELF CENTERING MACHINE VISES

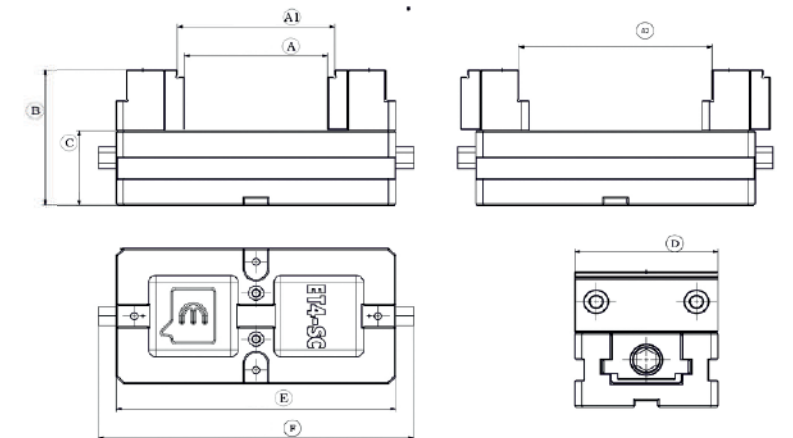

Construction:

- High stress tensile stress Relieved quality casting, precision ground hardened and tempered bed & jaw plate. Complete with Handle
- Forged Still body to resist high impact load during machining.

Application:

Self centering vise is a powerful workholding device that helps improve machining precision and repeatability. They feature two jaws that move in equal and opposite directions, so they automatically adjust the workpiece to the center of the vise - making it ideal for drilling, tapping, boring and finishing applications on CNC machines

Self-centering vises are also designed to be easy to operate, so they can help you increase efficiency and productivity in your workshop. For example, some models are designed with a push button for quick, easy jaw adjustment and release. Others have a ratchet handle for fast, precise jaw clamping.

Features:

- Vise bodies are constructed of close grained, high tensile, seasoned ductile iron castings
- Hardened Bad Graunded.
- ACCURACY WITHIN 0.02mm.

- STANDARD ACCESSORIES
- 1 Work Stopper
- 1 Adjustable Handle

Order No. & Dimension (mm)

Model No.	A	A2	B	C	D	E	F	G	H	MAX Clamp Force (kgf)	G.W. (KGS)	CODE NO.
ET-SC	40	140	100	55	100	195	220	18	N/A	2000	8	ET-SC

ENGEETECH STANDARD VISES 4A, 6A, 8A, 10A & 12A

ENGEETECH MACHINE VISE ACCESSORIES

Products

Description

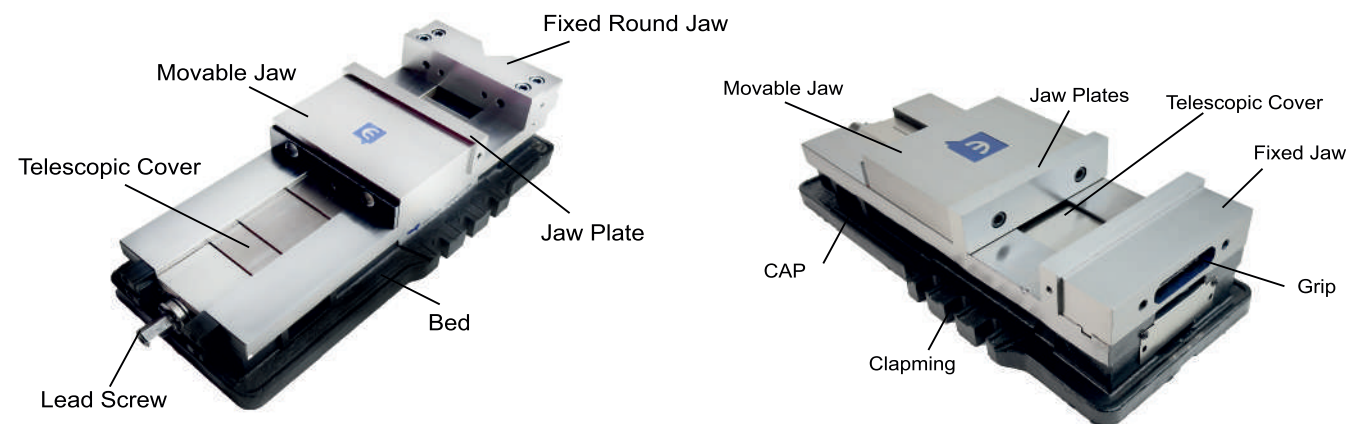
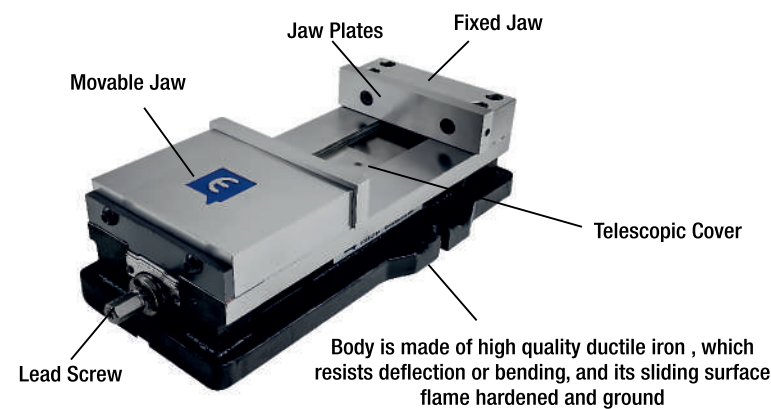
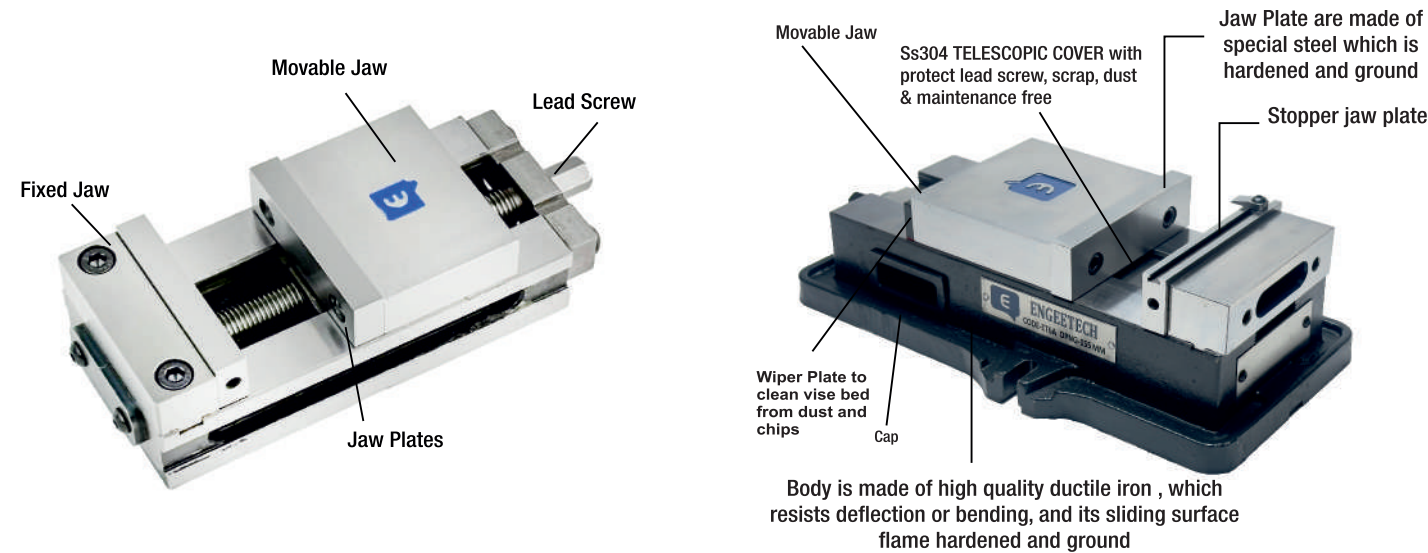

OPEN AND CLOSE HANDLE



ANGULAR JAW PLATE



STOPPER JAW PLATE



WISE CLAMP



LEAD SCREW

Open the Vise: Use the handle to open the jaws of the vise wide enough to accommodate your workpiece.
Place the Workpiece: Carefully place your workpiece between the jaws of the vise, ensuring it is positioned securely and evenly.
Close the Vise: Use the vise handle to tighten the jaws around the workpiece. Apply enough pressure to hold the workpiece firmly in place, but be careful not to over-tighten and damage the workpiece.
Perform the Operation: With the workpiece securely held in the vise, you can now perform whatever machining or other operations you need to do.
Release the Workpiece: Once you're finished with the operation, loosen the vise jaws using the handle and remove your workpiece.

Opening and Closing: The jaws of the vise can be opened or closed using a handle or a crank. This allows for accommodating various sizes of workpieces.
Adjustability: Some vises come with features for adjusting the angle or position of the jaws to accommodate different machining requirements.

Adjust the Vise: Loosen the vise's locking mechanism or adjustment screws to allow the jaws to be moved. Use a protractor or angle gauge to set the desired angle accurately.

Secure the Workpiece: Once you have set the vise to the desired angle, carefully place your workpiece between the jaws of the vise. Make sure it is positioned securely and evenly.

Tighten the Vise: Use the vise handle to tighten the jaws around the workpiece. Apply enough pressure to securely hold the workpiece in place at the desired angle.

Perform the Machining Operation: With the workpiece securely held in the vise at the desired angle, you can now perform the machining operation, such as milling, drilling, or grinding.

Prepare the Machine Table: Ensure that the machine table has T-slots that match the T-nuts on the bottom of the vise. Clean the T-slots and make sure they are free of debris.

Insert T-nuts: Place T-nuts into the T-slots on the machine table. The number of T-nuts needed depends on the size and configuration of the vise.
Position the Vise: Position the vise on the machine table so that the T-nuts on the bottom of the vise align with the T-slots on the table.

Centering: Screw vises usually have features for centering the workpiece accurately within the vise jaws. This ensures that the workpiece is held securely and concentrically during machining operations.

ENGEETECH MACHINE VISE ACCESSORIES

Products



ANGULAR JAW PLATE



DIAMOND JAW PLATES



ROUND JAW



STOPPER JAW PLATE

Description

Machine vises are essential tools in machining and manufacturing industries, where precision and stability are paramount. To enhance the functionality of machine vises, advanced angular jaw plates have been developed, providing a significant upgrade over traditional flat jaw plates. These advanced components are designed to handle complex workpieces with irregular shapes, offering improved grip, versatility, and accuracy during machining operations. Angular jaw plates are specialized components that attach to the jaws of a machine vise, replacing the standard flat plates. These plates are designed with angled surfaces, which can vary in degree depending on the specific application. The angular design allows for better clamping of irregularly shaped or angular workpieces, ensuring that they are held securely and at the correct orientation during machining.

Rough jaw plates are engineered with a textured or serrated surface, which increases the friction between the jaw plates and the workpiece. This design is particularly effective for gripping materials that are rough, uneven, or prone to slipping under pressure, such as castings, forgings, and other raw materials. The serrations or raised patterns on the surface of the jaw plates bite into the workpiece, providing a more secure hold than smooth or flat jaw plates. One of the key advantages of rough jaw plates is their ability to maintain a strong grip on challenging workpieces without applying excessive clamping force. In some cases, applying too much force can damage the workpiece or cause it to deform. Rough jaw plates, however, achieve a firm grip through their textured surface, reducing the need for high clamping pressure and minimizing the risk of workpiece damage.

Round jaw plates are specialized attachments designed to replace the standard flat jaws of a machine vise. These plates feature a concave, circular design that allows them to grip cylindrical or round objects more effectively than traditional flat jaws. The curvature of the round jaw plates matches the contour of the workpiece, distributing the clamping force evenly across its surface. One of the key advantages of round jaw plates is their ability to securely hold round or cylindrical objects, such as pipes, rods, and shafts, which are challenging to clamp with flat jaws. Flat jaws often exert pressure unevenly on these shapes, leading to slippage or deformation of the workpiece. Round jaw plates, however, provide a more uniform grip, reducing the risk of movement during machining and ensuring greater accuracy.

Stopper jaw plates are designed to attach to the jaws of a machine vise, introducing a built-in stopper or reference edge against which the workpiece can be positioned. This stopper serves as a fixed point of contact, ensuring that the workpiece is consistently aligned in the same position each time it is clamped. The design of these jaw plates can vary, with some featuring adjustable stoppers to accommodate different workpiece sizes, while others may have fixed stoppers designed for specific applications. The primary function of a stopper jaw plate is to provide a reliable and repeatable reference point, which is especially important in precision machining operations where even minor deviations in workpiece positioning can lead to

ENGEETECH STANDARD VISE 4A, 6A, 8A, 10A & 12A

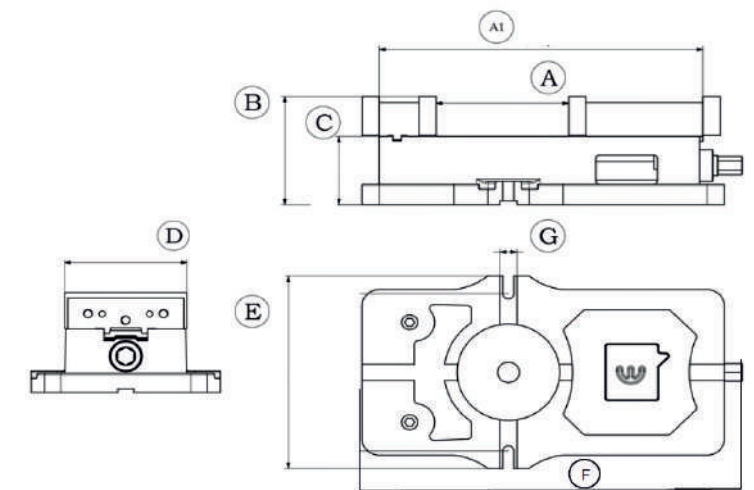

Application

Drilling: When drilling holes into workpieces, a Standard machine vise can securely hold the piece in place, preventing movement or misalignment during drilling. This ensures precise hole placement and depth.

Milling: Standard machine vises are often used in milling machines to hold workpieces securely while milling operations such as drilling, cutting, or shaping are performed. They provide stability and precision, ensuring accurate machining.

Prototyping: In prototyping or small-scale production environments, Standard vises are invaluable for holding workpieces securely during machining operations, allowing for the creation of precise prototypes or small batches of parts.

Technical Parameter

- Suitable for Heavy duty cutting.
- Hardened Bad Graunded.
- High durability & high precision.
- Tolerance : 0.02 Overall
- Lift proof : press down design.
- Two setting positions of the jaw plates are available, widening the jaw plates opening.
- ACCURACY WITHIN 0.02mm.
- Unique Technology with SS304 Telescope cover to prevent lead screw Routine maintenance and rust preventive

Construction

- High stress tensile stress Relieved quality casting,
- precision ground hardened and tempered bed & jaw plate
- Complete with Handle
- Ductile Iron Body to resist high impact load

Features

- Vise bodies are constructed of close grained, high tensile, ductile iron castings
- Hardened Bad.
- Hardness of Jaws 45-50 HRC
- STANDARD MACHINE VISE 6"JAW OPENED 155mm
- ACCURACY WITHIN 0.02mm.

Model No.	A	A1	B	C	D	E	F	G	MAX Clamp Force (kgf)	G.W. (KGS)	CODE NO.
ET 4A	100	NA	80	50	100	140	260	13	1500	9	ET 4A
ET 6A	150	375	135	85	155	240	445	18	2500	32	ET 6A
ET 8A	200	465	147	94	210	272	553	18	3500	45	ET 8A
ET 10A	250	520	147	94	210	272	595	18	3500	55	ET 10A
ET 12A	300	480	147	94	210	258	595	18	4000	60	ET 12A

ENGEETECH COMPACT VISES 4C, 6C, 8C, 10C & 12C

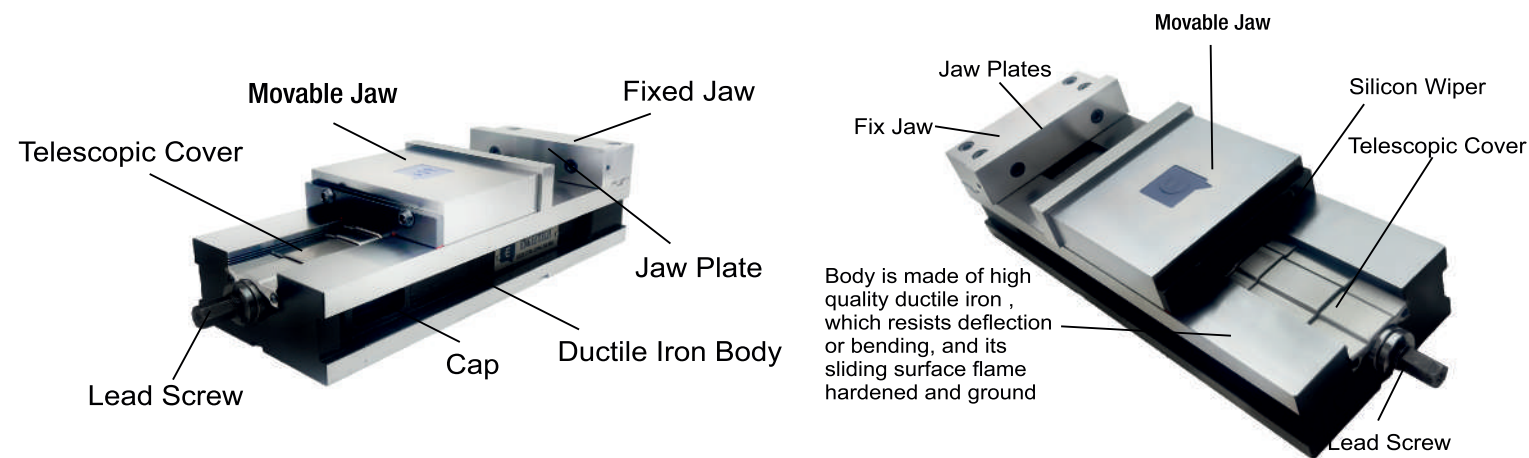
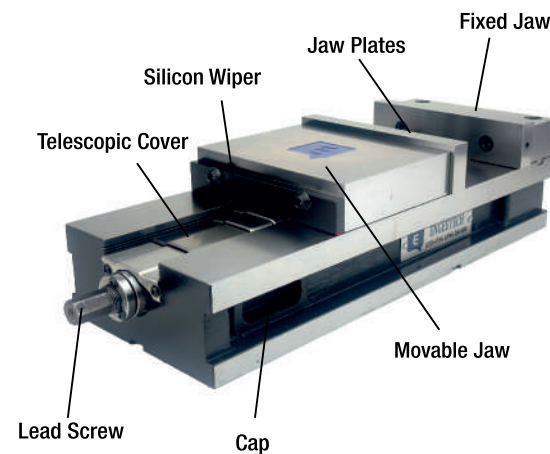
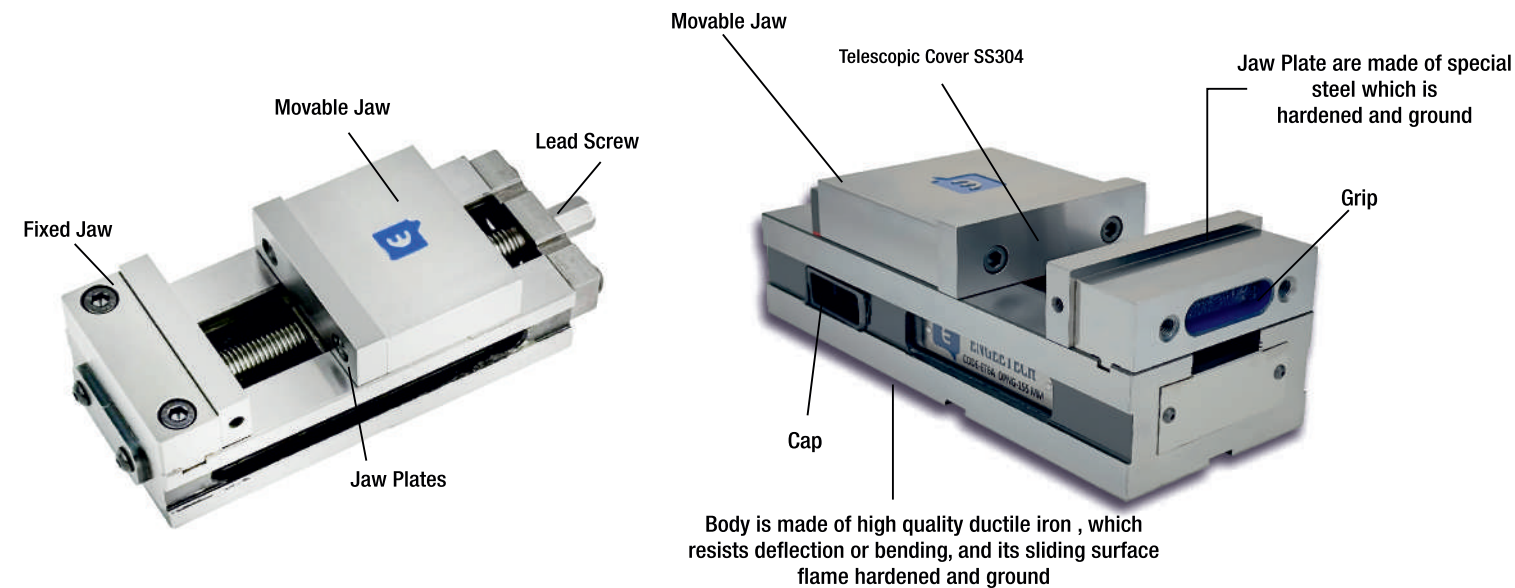

ENGEETECH CHUCK VISE 6"

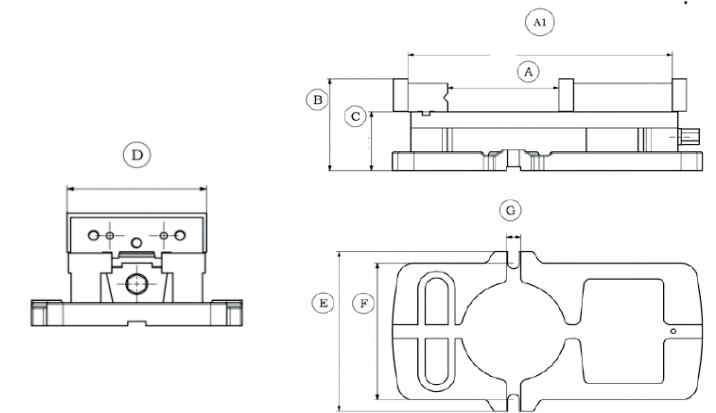
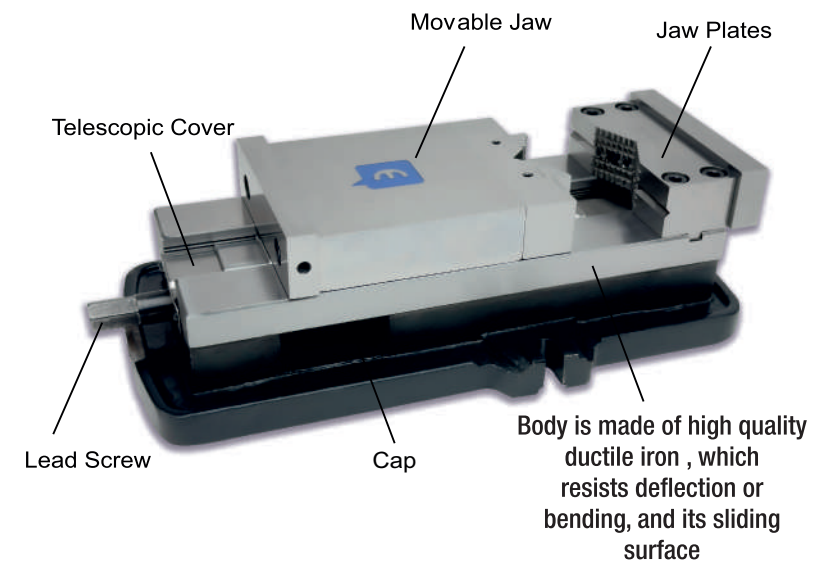

Features

- OD clamping devices are designed to clamp onto the outer diameter (OD) of the workpiece or tool. OD Clamping is common with machining chucks used application such as mill
- Locking chucks can be locked or set to provide holding force, even when the actuation mechanism is removed.
- Through-hole chucks have a center through-hole for chucking or gripping long sections of stock, pipe etc.
- Manual chucks are adjusted and tightened by the operator's hands.
- Special ductile iron, hardened and ground
- Hardness of Jaws 50+ 5 HRC
- Chuck Jaw Machine Vise 6" Jaw Opened 155 mm
- Accuracy within 0.01mm to 0.02 mm
- Lift proof: Press down design

Technical Parameter

- Suitable for heavy duty cutting
- Hardened Bad Grounded
- High durability & High precision
- Tolerance: 0.02 Overall
- Lift Proof: Press down design
- Hardness of Jaws 50+ 5HRC
- Unique technology with SS304 telescope cover to prevent lead screw maintenance and rust preventive
- Two setting positions of the jaw plates are available, widening the jaw plates opening
- Accuracy within 0.02 mm.

Application

- Grinding Machines
- Heavy cutting processes by, milling Drilling machines and planers
- Metallic mold machining

- STANDARD ACCESSORIES
- 1 Work Stopper
- 1 Adjustable Handle

Order No. & Dimension (mm)

Model No.	A	A1	B	C	D	E	F	G	MAX Clamp Force (kgf)	G.W. (KGS)	CODE NO.
ET 6C	155	375	130	80	155	150	420	18	2500	30	ET 6C

ENGEETECH 4" SURFACE GRINDING MACHINE VISE

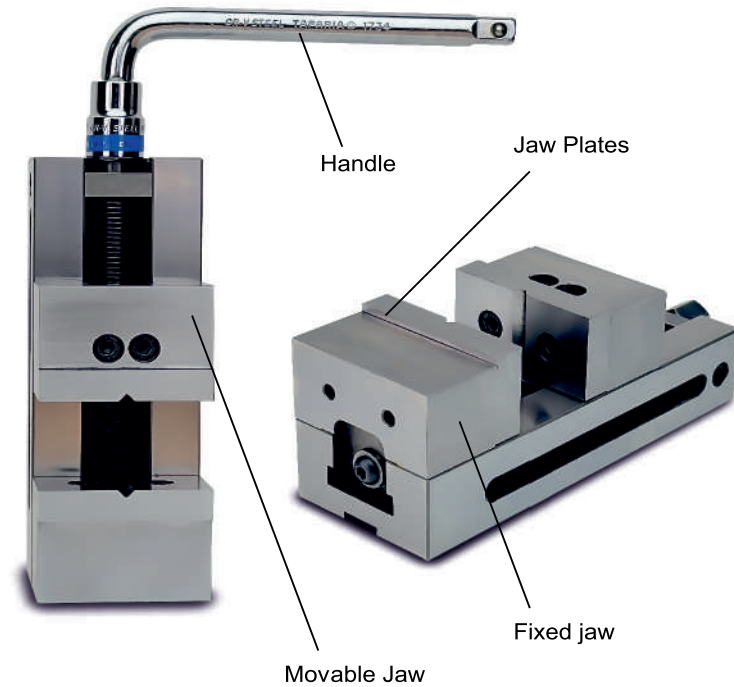

- Stability:** Provides a stable and secure hold on the workpiece, reducing vibrations and movement during the grinding process.
- Precision:** Ensures high precision in grinding operations, which is critical for achieving tight tolerances and excellent surface finishes.
- Versatility:** Can be used for a wide range of applications, from flat surface grinding to complex angle grinding and finishing.
- Efficiency:** Increases efficiency by allowing multiple parts to be ground simultaneously and by reducing setup times with repeatable positioning.
- Safety:** Enhances safety by securely holding the workpiece, minimizing the risk of movement or slippage during grinding.

Features

- Vise bodies are constructed of close grained, high tensile, ductile iron castings
- Hardness of Jaws 45-50 HRC
- MINI MACHINE VISE 4" JAW OPENED 105mm
- ACCURACY WITHIN 0.01 -0.02mm.
- Special ductile iron, hardened with 180-220 BHN

Application

- Surface Grinding & Engraving Application

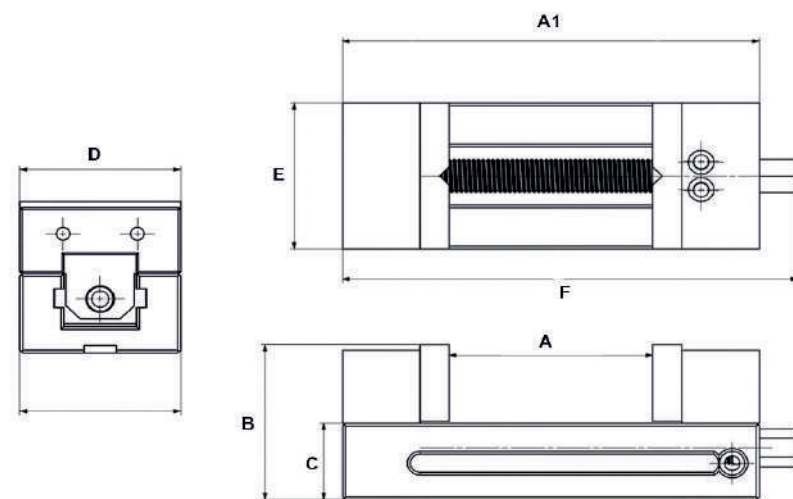

- STANDARD ACCESSORIES
- 1 Work Stopper
- 1 Adjustable Handle

Order No. & Dimension (mm)

Model No.	A	A1	B	C	D	E	F	G	H	MAX Clamp Force (kgf)	G.W. (KGS)	CODE NO.
ET-4A	105	205	85	42	80	80	235	N/A	N/A	800	7	ET-4A

ENGEETECH STANDARD VISE 6C, 8C, 10C & 12C

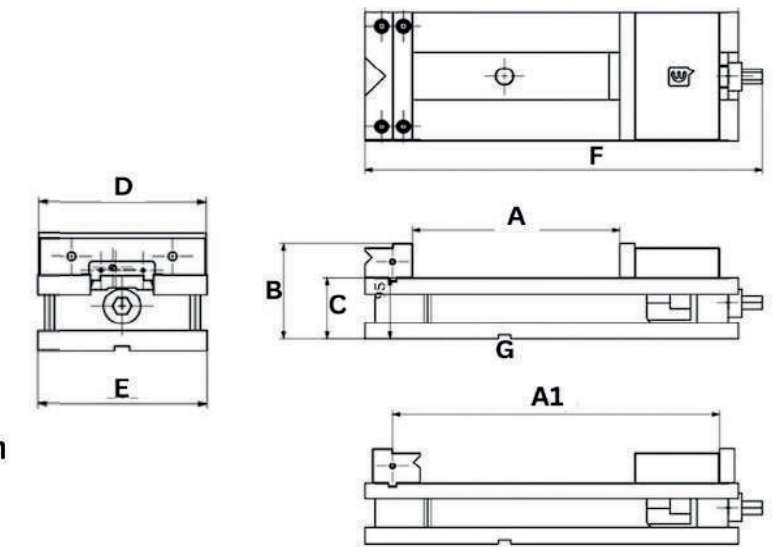

Construction:

- High stress tensile stress Relieved quality casting, precision ground hardened and tempered bed & jaw plate.
- Complete with Handle.
- Ductile Iron Body to resist high impact load during machining.

Application:

- MILLING: Compact 12 inch machine vises are often used in milling machines to hold workpieces securely while milling operations such as drilling, cutting, or shaping are performed. They provide stability and precision, ensuring accurate machining.
- DRILLING: When drilling holes into workpieces, a Compact machine vise can securely hold the piece in place, preventing movement or misalignment during drilling. This ensures precise hole placement and depth.
- GRINDING: In precision grinding operations, a Compact vise can be used to securely clamp small workpieces for precise grinding and finishing operations.
- PROTOTYPE: In prototyping or small-scale production environments, Compact vises are invaluable for holding workpieces securely during machining operations, allowing for the creation of precise prototypes or small batches of parts.

Technical Parameter

- Suitable for Heavy duty cutting.
- Hardened Bad Grounded
- Tolerance : 0.02 Overall
- Lift proof : press down design.
- Hardness of Jaws 45-50 HRC
- Unique Technology with SS304 Telescope cover to prevent lead screw maintenance and rust preventive.
- Two setting positions of the jaw plates are available, widening the jaw plates opening.
- ACCURACY WITHIN 0.02mm.

Features:

- Vise bodies are constructed of close grained high tensile, seasoned ductile iron castings
- Hardened Bad Grounded.
- ACCURACY WITHIN 0.02mm.

Model No.	A	A1	B	C	D	E	F	G	MAX Clamp Force (kgf)	G.W. (KGS)	CODE NO.
ET 4C	100	NA	80	50	100	100	260	240	1500	8	ET 4C
ET 6C	150	375	130	80	150	150	420	18	2500	30	ET 6C
ET 8C	200	465	149	96	200	202	510	18	3500	42	ET 8C
ET 10C	250	520	149	96	200	202	575	18	3500	55	ET 10C
ET 12C	300	480	148	95	200	202	585	18	4000	60	ET 12C

Engeetech Precision Modular PULLDOWN MACHINE VISES 8", 12" and Split Vise

Engeetech Precision Modular PULLDOWN MACHINE VISES 8", 12" and Split Vise

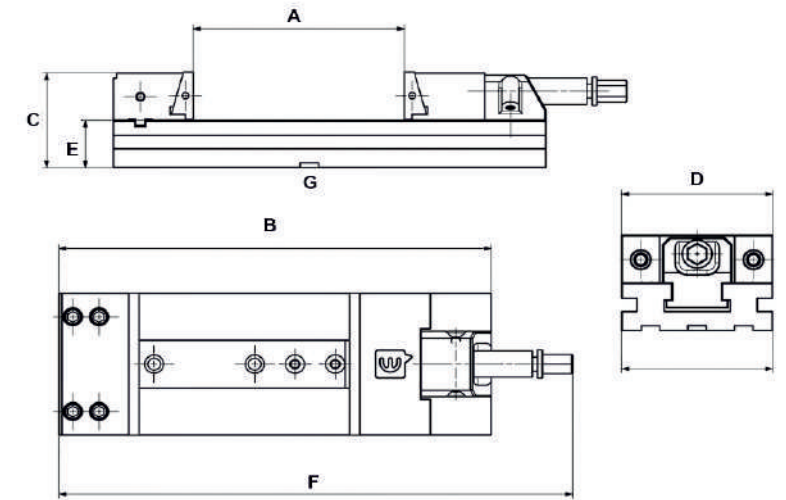
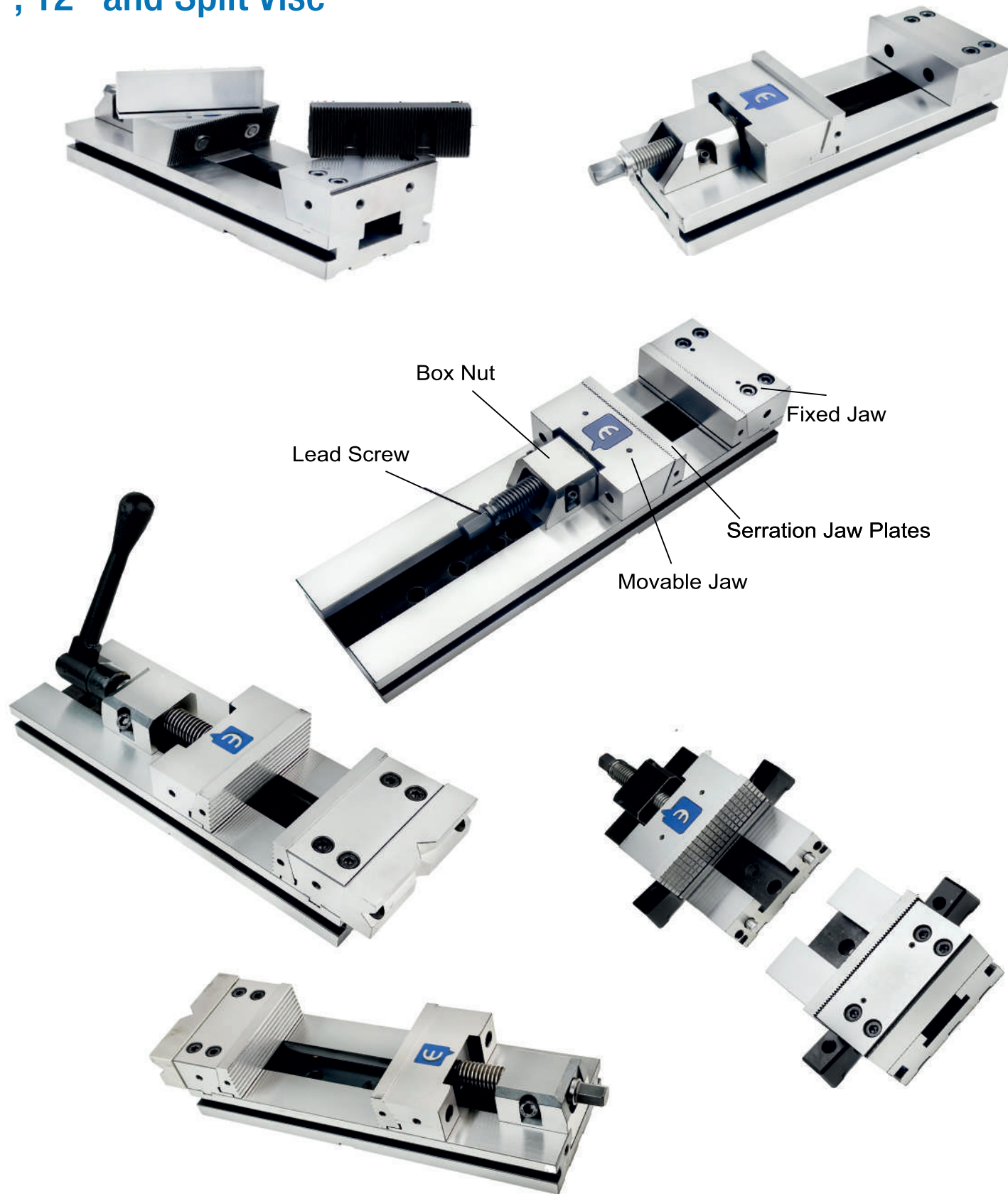

Features

Forged Material

- Grain Structure: Forging refines the grain structure of the metal, enhancing its strength and toughness.
- Fatigue Resistance: Components made from forged alloy steel have better fatigue resistance, which means they can endure repeated loading and unloading cycles.
- Consistency: Forging eliminates internal voids and porosity, resulting in more uniform and reliable parts.
- mm
- ACCURACY Within 0.02 mm
- Lift proof : press down design

Case Carburizing

Carbon Enrichment: The surface of the steel is exposed to a carbon-rich environment at high temperatures, which allows carbon to diffuse into the surface.

Hardening: The enriched surface layer is then quenched, resulting in a hard, wear-resistant outer layer with a softer, tougher interior .

Wear Resistance: The hard surface resists wear and abrasion, extending the life of the vise.

Application

- CNC Machining: Suitable for high-precision CNC machining operations where stability and accuracy are crucial.
- Metalworking: Ideal for various metalworking tasks such as milling, drilling, and grinding.
- Heavy-Duty Applications: Used in environments where the vise is subjected to high forces and repetitive use.
- High Clamping Force: The vise can generate and withstand high clamping forces due to its strong material properties.
- Durability: Alloy steel construction and forging make the

Alloy Steel Construction

increased Strength: Alloy steel is stronger than standard carbon steel, allowing the vise to withstand higher clamping forces without deforming.

Improved Toughness: The material is more resistant to impacts and shocks, making it durable under heavy machining loads.

Enhanced Wear Resistance: Alloy steel has better wear resistance, which is crucial for a tool that will undergo constant use and pressure.

- Special Alloy Steel Case Carburizing 50 +- 5 HRC

Model No.	A	B	C	C1	D	D1	E	F	G	H	MAX Clamp Force (kgf)	G.W. (KGS)	CODE NO.
ET-8PM	225	430	100	N/A	150	N/A	50	511	18	N/A	4500	33	ET-8PM
ET 12PM	325	530	100	N/A	150	N/A	50	608	18	N/A	4500	38	ET 12PM
ET SPL	Limit Less	335	100	N/A	150	N/A	50	365	18	N/A	4500	38	ET SPL