



2025  
Edition

**Timus Tooling System Pvt Ltd**



*Where quality is never compromised...*

AN ISO 9001 : 2015 CERTIFIED COMPANY

**MARKET LEADER IN SAWS**



[www.timustooling.com](http://www.timustooling.com)



# INDEX



## T.C.T Circular Saw Blades

Page 1 - 11



## TCT Brazed Router Bits

Page 12 - 30

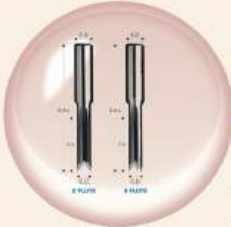

## HSS Slot Mortising Drill Bits

Page 31 - 31



## Solid Carbide Router Bits

Page 32 - 42



## T.C.T Boring Bits

Page 43 - 46



## T.C.T Grooving & Postforming Cutters

Page 47 - 55





# INDEX



## T.C.T Planning Cutterheads

Page 56 - 62



## Edge Rounding & Tenoning Cutters

Page 63 - 73



## T.C.T Replaceable Knives

Page 74 - 77



## Mortising Tools & Finger Joint Cutters

Page 78 - 80



## Clamping System & PCD Tools

Page 81 - 83



## Accessories and Hand Tools

Page 84 - 86



## Panel Saw Blades for Bi-Laminated MDF and Particle Board



### Application

For sizing bi-laminated panels along with the use of scoring saw blade with good finish and long cutting life.

### Tooth Profile

Flat-Triple Chip Tooth with Positive Cutting

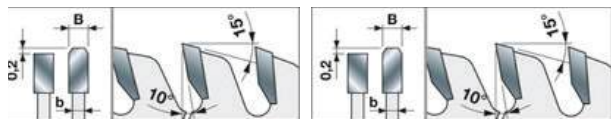

### Materials

MDF, Particle Boards, Bi-Laminated Panels, Melamine Coated Panels.



### Machines

Horizontal Panel Saw, Circular

### PCD SAW BLADES (30 TIMES MORE LIFE)

D	B	b	d	Z	Pinholes	Code	Price
250	3.2	2.2	30	80	TT01	MI DPB 500	21700
300	3.2	2.2	30	96	TT01	MI DPB 600	28000
350	3.5	2.5	30	108	TT02	MI DPB 601	32500

TT01 : 2/7/42 + 2/9/46,4 + 2/10/60 TT02 : 2/9/46,4 + 2/10/60

D	B	b	d	Z	Pinholes	Code	Price
250	3.2	2.2	30	80	TT01	MI PB 500	4510
300	3.2	2.2	30	72	TT01	MI PB 510	4960
300	3.2	2.2	30	96	TT01	MI PB 600	4600
350	3.5	2.5	30	108	TT02	MI PB 601	6940

\*Special sizes available as per customer needs.



**Saw Blade for Solid Wood, Panels and Composites**



**Application**

For Ripping and Crosscutting

**Tooth Profile**

ATB Tooth with Positive Cutting Angle.

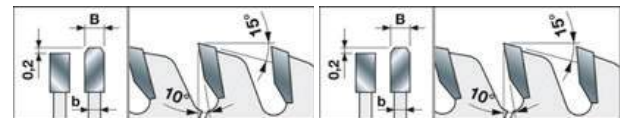

**Materials**

Softwood, Hardwood, Chipboard, Plywood and MDF.



**Machines**

Squaring saws and horizontal panel sizing machines.

D	B	b	d	Z	Pinholes	Code	Price
250	3.2	2.2	30	40	TT01	MI 2A 500	3700
300	3.2	2.2	30	48	TT01	MI 2A 600	3970
350	3.5	2.5	30	54	TT02	MI 2A 700	6400
400	4.0	2.8	30	60	2/10/60	MI 2A 800	9100
450	4.4	3.0	30	66	2/10/60	MI 2A 900	13600
500	4.4	3.2	30	72	2/10/60+2/10/80	MI 2A 1000	16300
550	4.8	3.5	30	84	2/10/60+2/10/80	MI 2A 1100	19000
600	5.4	4.0	30	96	2/10/80	MI 2A 1200	24400

\*Special sizes available as per customer needs.



## Saw Blade for Solid Wood, Panels and Composites

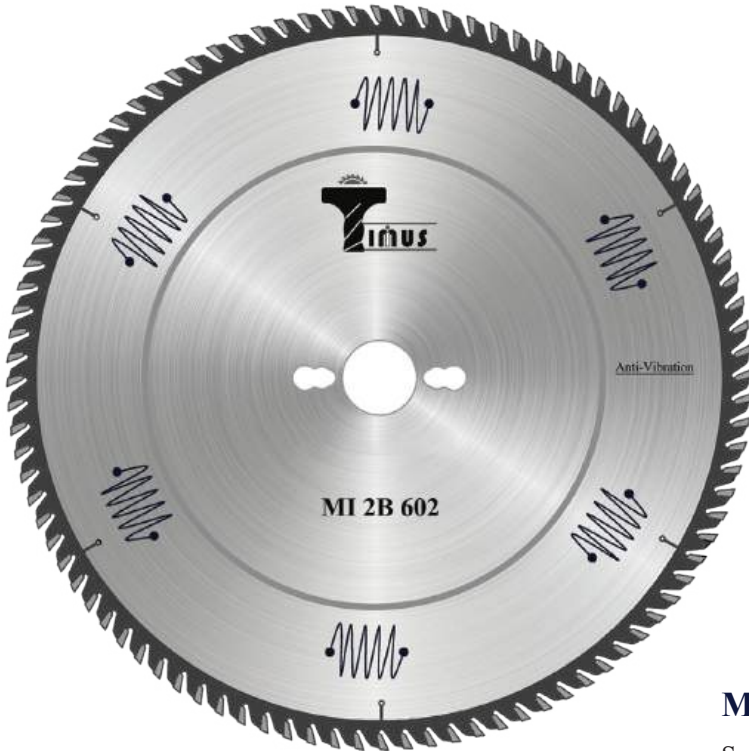

### Application

For Ripping and Crosscutting.

### Tooth Profile

Tooth Profile.

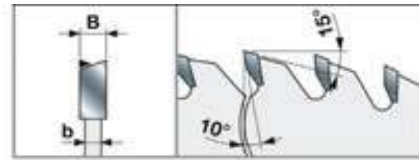

### Materials

Softwood, Hardwood, Chipboard, Plywood and MDF.



### Machines

Squaring saws and horizontal panel sizing machines.

D	B	b	d	Z	Pinholes	Code	Price
250	3.2	2.2	30	48	TT01	MI 2B 501	3970
250	3.2	2.2	30	60	TT01	MI 2B 502	4240
300	3.2	2.2	30	60	TT01	MI 2B 601	4600
300	3.2	2.2	30	72	TT01	MI 2B 602	4960
350	3.5	2.5	30	72	TT02	MI 2B 701	6940
350	3.5	2.5	30	84	TT02	MI 2B 702	7300
400	4.0	2.8	30	96	2/10/60	MI 2B 801	9100
450	4.4	3.0	30	96	2/10/60	MI 2B 900	14500
550	4.8	3.5	30	108	2/10/60+2/10/80	MI 2B 1100	19900
600	5.4	4.0	30	132	2/10/80	MI 2B 1200	28000

\*Special sizes available as per customer needs.



**Saw Blade for Solid Wood, Panels and Composites**

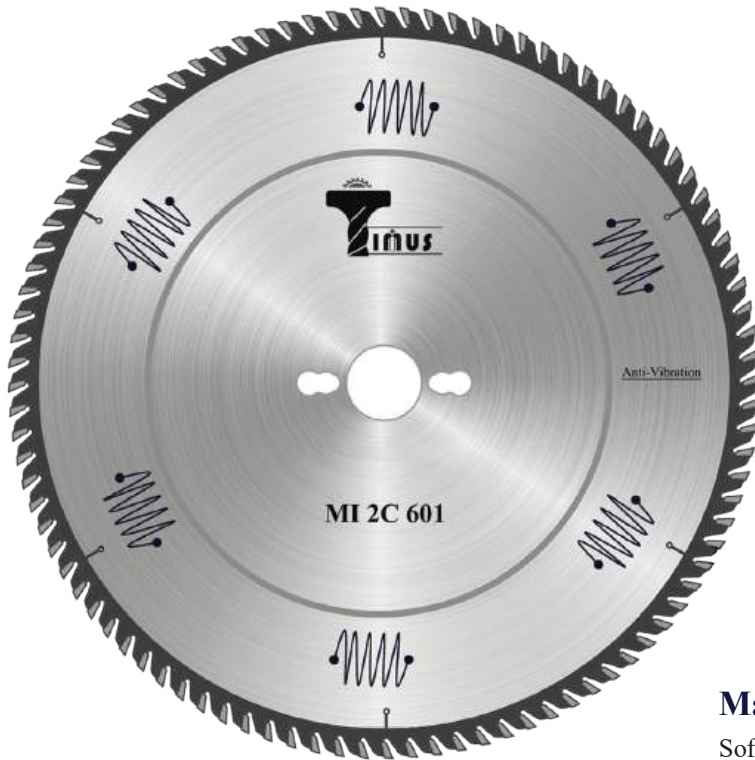

**Application**

For Crosscutting.

**Tooth Profile**

ATB Tooth with Positive Cutting Angle.

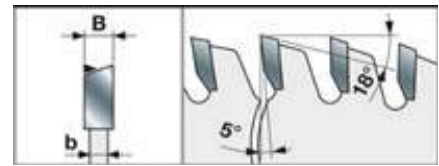

**Materials**

Softwood, hardwood, chipboard, laminated MDF and thermoplastic composites



**Machines**

Squaring saws and horizontal panel sizing machines.

D	B	b	d	Z	Pinholes	Code	Price
250	3.2	2.2	30	80	TT01	MI 2C 501	4600
250	3.2	2.2	30	100	TT01	MI 2C 502	4960
300	3.2	2.2	30	96	TT01	MI 2C 601	4780
300	3.2	2.2	30	120	TT01	MI 2C 602	5500
350	3.5	2.5	30	108	TT02	MI 2C 700	6940
400	3.8	2.8	30	120	2/10/60	MI 2C 800	9910
450	4.4	3.0	30	132	TT02	MI 2C 900	13600
500	4.4	3.2	30	144	2/10/60+2/10/80	MI 2C 1000	17200
550	4.8	3.5	30	156	2/10/60+2/10/80	MI 2C 1100	26200
600	5.4	4.0	30	168	2/10/80	MI 2C 1200	28000

\*Special sizes available as per customer needs.



## Saw Blade for Panel Sizing on Beam Saw Machine

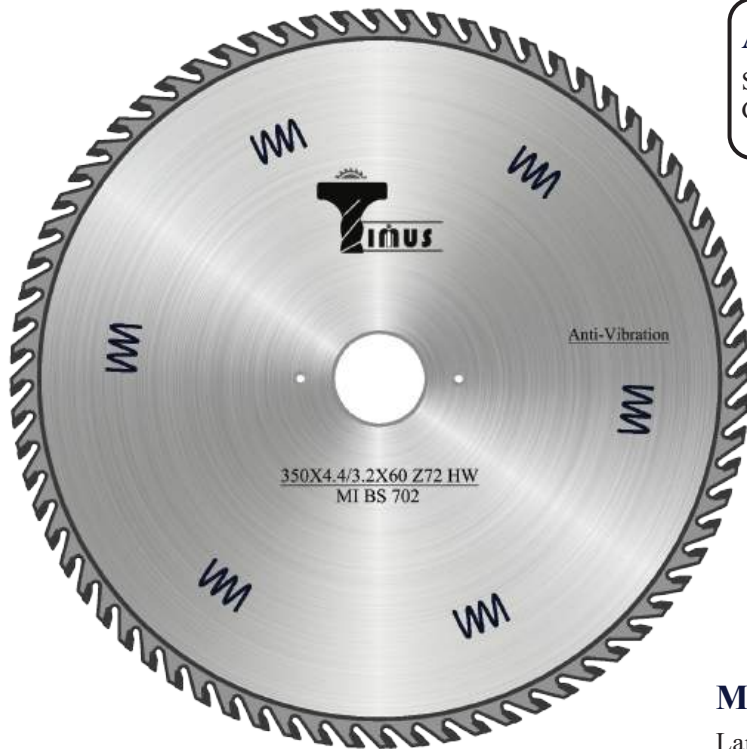

### Application

Suitable for chipboard and MDF bi-laminated panels. Good finishing also in HPL and acrylic panel cutting.

### Tooth Profile

Flat Triple-Chip Tooth.

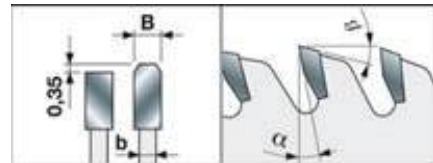

### Materials

Laminated chipboard, laminated MDF, HPL, thermoplastic composites and plexiglas.

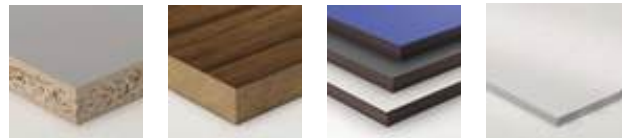

### Machines

Horizontal panel sizing machines.

D	B	b	d	Z	Pinholes	Code	Price
300	4.4	3.2	30	72	2/10/60	MI BS 601	9991
300	4.4	3.2	60	72	2/14/100	MI BS 602	10900
320	4.4	3.2	65	72	2/9/110	MI BS 640	9910
350	4.4	3.2	30	72	2/10/60	MI BS 701	11800
350	4.4	3.2	60	72	2/14/100	MI BS 702	11800
350	4.4	3.2	65	72	2/9/110	MI BS 703	11800
350	4.4	3.2	75	72	4/15/105	MI BS 704	11800
400	4.4	3.2	75	72	4/15/105	MI BS 800	16300
450	4.8	3.5	60	72	2/14/125	MI BS 900	19000

\*Special sizes available as per customer needs.



## Conical Scoring Saw Blades



### Application

To score the coating on bi-laminated panels.

### Tooth Profile

Conical Tooth.

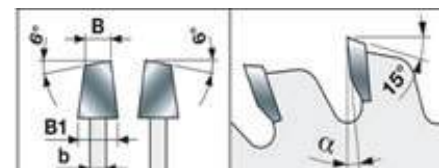

### Materials

Laminated Chipboard and Laminated MDF.



### Machines

Horizontal panel sizing machines and Squaring Saws.

### PCD CONICAL SCORING SAW BLADES

D	B	b	d	Z	Code	Price
100	2.8-4.0	2.2	20	24	MI DCS 100 01	7300
120	2.8-4.0	2.2	20	24	MI DCS 120 01	6940
120	2.8-4.0	2.2	22	24	MI DCS 120 02	6940

D	B	b	d	Z	Code	Price
100	2.8-4.0	2.2	20	24	MI CS 100 01	2800
120	2.8-4.0	2.2	20	24	MI CS 120 01	2980
120	2.8-4.0	2.2	22	24	MI CS 120 02	2980
150	4.3-5.5	2.2	30	36	MI CS 150 01	6220
150	4.3-5.5	2.2	45	36	MI CS 150 02	6220
160	4.3-5.5	2.2	30	36	MI CS 160 01	6400
160	4.3-5.5	2.2	45	36	MI CS 160 02	6940
180	4.3-5.5	2.2	30	36	MI CS 180 01	6940
180	4.3-5.5	2.2	45	36	MI CS 180 02	6940
200	4.3-5.5	2.2	45	36	MI CS 200 01	6670
200	4.3-5.5	2.2	65	36	MI CS 200 02	6400

\*Special sizes available as per customer needs.



## Adjustable Scoring Saw Blades



### Application

To score the coating on bi-laminated panels.

### Tooth Profile

ATB Tooth Profile.



### Materials

Laminated Chipboard and Laminated MDF.



### Machines

Horizontal panel sizing machines and Squaring Saws.

D	B	d	Z	Code	Price
80	2.8-3.6	20	10+10	MI AS 80 01	3520
100	2.8-3.6	20	12+12	MI AS 100 01	3520
100	2.8-3.6	22	12+12	MI AS 100 02	3520
120	2.8-3.6	20	12+12	MI AS 120 01	3520
120	2.8-3.6	22	12+12	MI AS 120 01	3520
100	2.8-4.0	2.2	20+24	MI DCS 100 01	7300
120	2.8-4.0	2.2	20+24	MI DCS 120 01	6940
120	2.8-4.0	2.2	22+24	MI DCS 120 02	6940
100	2.8-3.6	20	12+12	MI DAS 100 01	6400
120	2.8-3.6	20	12+12	MI DAS 120 01	6400
120	2.8-3.8	22	12+12	MI DAS 120 02	6400

### PCD ADJUSTABLE SCORING SAW

D	B	d	Z	Code	Price
100	2.8-3.6	20	12+12	MI DAS 100 01	6400
120	2.8-3.6	20	12+12	MI DAS 120 01	6400
120	2.8-3.8	22	12+12	MI DAS 120 02	6400

\*Special sizes available as per customer needs.



**Saw Blade for Non-Ferrous and UPVC**



**Application**

Suitable for cutting UPVC and Non-Ferrous Metals.

**Tooth Profile**

Flat Triple-Chip Tooth.

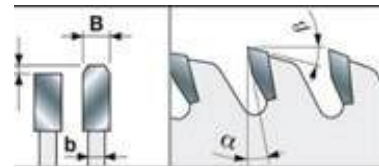

**Materials**

Aluminium, copper, brass, UPVC etc.



**Machines**

Double head cutting machines, CNC cutting units, Mitre Saws.



D	B	b	d	Z	Pinholes	Code	Price
250	2.8	2.2	30	100	TT01	MI NF 500	4600
255	2.8	2.2		100		MI NF 510	4780
300	3.0	2.5	30	100	TT02	MI NF 602	5500
300	3.0	2.5	30	120	TT02	MI NF 603	5995
350	3.0	2.5	30	100	TT02	MI NF 702	6400
350	3.0	2.5	30	120	TT02	MI NF 703	6670
380	3.5	3.0	32	112	2/11/63	MI NF 760	11800
400	3.5	3.0	30	96	2/11/63	MI NF 800	10900
400	3.5	3.0	30	120	2/11/63	MI NF 801	11800
420	3.5	3.0	30	96	2/11/70	MI NF 840	11800
420	3.5	3.0	30	120	2/11/70	MI NF 841	12700
450	4.0	3.2	30	128		MI NF 901	14500
500	4.0	3.2	30	120	2/10.5/70	MI NF 1000	15400
550	4.2	3.5	30	132	2/10.5/70	MI NF 1100	19000
600	4.8	3.8	30	156		MI NF 1200	25300

\*Also available in PCD

\*Special sizes available as per customer needs.



## Straight Line Rip Saw



### Application

For Ripping on straight line rip saw machine.

### Tooth Profile

Special Tooth Shape-ATB with Face Shear Angle.

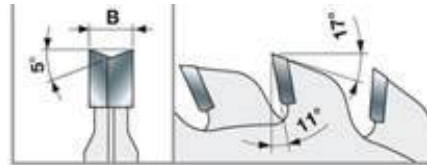

### Materials

Solid Wood.



### Machines

Straight Line Rip Saw Machine.

D	B	d	Z	Pinholes	Code	Price
305	5.0	50.8	48	2/16/29	MI RIP 600	8920
355	5.0	50.8	70	2/16/29	MI RIP 710	10540
405	5.0	50.8	70	2/16/29	MI RIP 810	13600
455	5.0	50.8	70	2/16/29	MI RIP 860	17200

\*Also available in PCD

\*Special sizes available as per customer needs.



**Multi-Ripping Saw Blades with Rakers**



**Application**

Saw Blade suitable for Ripping.

**Tooth Profile**

Flat Triple-Chip Tooth.

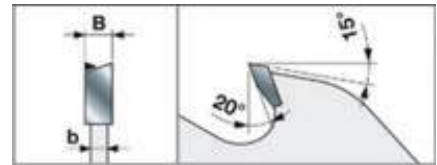

**Materials**

Soft and Hardwood.



**Machines**

Multi-ripping Machines.

D	B	b	d	Z	Pinholes	Code	Price
250	3.2	2.2	30	20+2+2	2CH 10X4 + TT02	MR 04 0100	5500
250	3.2	2.2	60	20+2+2	4CH 21X5	MR 04 0200	5500
250	3.2	2.2	70	20+2+2	4CH 21X5	MR 04 0300	5500
250	3.2	2.2	80	20+2+2	2CH 13X5 + 2CH 21X5	MR 04 0400	5500
300	3.2	2.2	30	24+2+2	2CH 10X4 + TT02	MR 04 0500	5770
300	3.2	2.2	60	24+2+2	4CH 21X5	MR 04 0600	5770
300	3.2	2.2	70	24+2+2	4CH 21X5	MR 04 0700	5770
300	3.2	2.2	80	24+2+2	2CH 13X5 + 2CH 21X5	MR 04 0800	5770
350	3.5	2.5	30	28+2+4	2CH 10X4 + TT02	MR 04 1100	7930
350	3.5	2.5	60	28+2+4	4CH 21X5	MR 04 1200	7930
350	3.5	2.5	70	28+2+4	4CH 21X5	MR 04 1300	7930
350	3.5	2.5	80	28+2+4	2CH 13X5 + 2CH 21X5	MR 04 1400	7930
400	4.0	2.8	30	28+2+4	2CH 10X4 + TT02	MR 04 1500	9910
400	4.0	2.8	70	28+2+4	4CH 21X5	MR 04 1600	9910
400	4.0	2.8	80	28+2+4	2CH 13X5 + 2CH 21X5	MR 04 1700	9910

\*Also available in PCD

\*Special sizes available as per customer needs.



## TCT Eco Range Saw Blades



### Application

For cutting wood, laminates and aluminium.

### Materials

Plywood, MDF, Chipboard, Aluminium etc.



### Machines

Hand Cutters, Portable Saws, Table Saws etc.

D	B	b	d	Z	Code	Price
110	2.0	1.2	20	30	ECO 04030	226
110	2.0	1.2	20	40	ECO 04040	253
127	2.0	1.2	20	30	ECO 05030	280
127	2.0	1.2	20	40	ECO 05040	298
180	2.3	1.5	25.4	40	ECO 07040	433
180	2.3	1.5	25.4	60	ECO 07060	460
200	2.4	1.6	25.4	40	ECO 08040	550
200	2.4	1.6	25.4	60	ECO 08060	568
230	2.8	1.8	25.4	40	ECO 09040	667
250	2.8	1.8	25.4	40	ECO 10040	676
250	2.8	1.8	25.4	60	ECO 10060	793
250	2.8	1.8	25.4	100	ECO AL 10100	1720
300	3.2	2.2	25.4/30	48	ECO 12048	1900
300	3.2	2.2	25.4/30	60	ECO 12060	2080
300	3.2	2.2	25.4/30	100	ECO AL 12100	2440
355	3.2	2.2	25.4/30	120	ECO AL 14120	3700
400	3.6	2.6	30	100	ECO 16100	5680
400	3.6	2.6	30	120	ECO AL 16120	6400
450	4.0	3.0	30	120	ECO AL 18120	9991
450	4.0	3.0	30	108	ECO AL 18108	9100
200	1.6	1.0	25.4	60	ECO TK 08060	541
250	1.8	1.2	25.4	40	ECO TK 10040	820
250	1.8	1.2	25.4	60	ECO TK 10060	991
300	2.2	1.8	25.4	60	ECO TK 12060	1450



\*Special sizes available as per customer needs.



## TCT Brazed Straight Bit - TT.SB



### Application

Ideal for grooving, edge-routing and other general purpose routing tasks.

### Materials

Softwood, hardwood, plywood and wood-based panels.



	C.D.	S.D.	C.L.	Z	PRICE
TT.SB.5620	5	6	20	2	550
TT.SB.6620	6	6	20	2	550
TT.SB.6820	6	8	20	2	550
TT.SB.61220	6	12	20	2	550
TT.SB.7825	7	8	25	2	595
TT.SB.71225	7	12	25	2	595
TT.SB.8625	8	6	25	2	595
TT.SB.8825	8	8	25	2	595
TT.SB.81225	8	12	25	2	595
TT.SB.81230	8	12	30	2	622
TT.SB.81235	8	12	35	2	694
TT.SB.91230	9	12	30	2	613
TT.SB.10625	10	6	25	2	613
TT.SB.10830	10	8	30	2	613
TT.SB.101220	10	12	20	2	613
TT.SB.101230	10	12	30	2	613
TT.SB.101238	10	12	38	2	766
TT.SB.101250	10	12	50	2	1990
TT.SB.12625	12	6	25	2	694
TT.SB.12830	12	8	30	2	694
TT.SB.121230	12	12	30	2	694
TT.SB.121238	12	12	38	2	820
TT.SB.121250	12	12	50	2	2053
TT.SB.121265	12	12	65	2	2800
TT.SB.121275	12	12	75	2	2998
TT.SB.151230	15	12	30	2	766
TT.SB.161230	16	12	30	2	775
TT.SB.181230	18	12	30	2	820
TT.SB.191230	19	12	30	2	820
TT.SB.201230	20	12	30	2	820
TT.SB.221230	22	12	30	2	910
TT.SB.251230	25	12	30	2	910
TT.SB.301230	30	12	30	2	1063

### Machines

Hand-held routers, table routers and CNC machines.



\*Special sizes available as per customer needs.

\*Also available in Replaceable Knives.

\*Also available in PCD



## TCT Brazed Straight Bit – Eco Range



CODE	C.D.	S.D.	C.L.	PRICE
120-A	4	8	12	298
120-B	4	6	12	298
120-C	4	6.35	12	298
120-D	4	12	12	352
120	6	8	15	307
120-AA	6	6	15	307
120-AB	6	6.35	15	307
120-AC	6	12	15	352
121	8	8	20	298
121-A	8	6	20	298
121-B	8	6.35	20	298
121-C	8	12	20	370
121-D	8	8	30	460
121-E	8	12	30	460
121-F	8	8	35	523
121-G	8	12	35	523
122	10	8	20	316
122-A	10	6	20	316
122-B	10	6.35	20	316
122-C	10	12	20	433
122-D	10	8	30	523
122-E	10	12	30	523
122-F	10	8	38	658
122-G	10	12	38	658
122-H	10	8	50	937
122-I	10	12	50	937
123	12	8	20	334
123-A	12	6	20	334
123-B	12	6.35	20	334
123-C	12	12	20	460
123-D	12	8	30	568
123-E	12	12	30	568
123-F	12	12.7	30	568
123-G	12	8	38	613
123-H	12	12	38	613
123-I	12	8	50	883
123-J	12	12	50	883
123-K	12	12	63	1081
123-L	12	12	75	1594
124-A	15	8	20	658
124-B	15	12	20	658
124-C	15	8	30	847
124-D	15	12	30	847
124-E	15	12	50	1315
124-F	15	12	63	1558
124-G	15	12	75	1837
124	19	8	25	748
124-AA	19	12	25	748
124-AB	19	8	38	1216
124-AC	19	12	38	1216
124-AD	19	12	50	1450
125	25	8	25	847
125-A	25	12	25	847
125-B	25	12	38	1324
125-C	25	12	50	1783

\*Special sizes available as per customer needs.



**TCT Brazed Straight Pattern Bit - TT.PB**



**Application**

Ideal for following templates and for other tasks where the pattern is placed on top of the workpiece.

**Materials**

Softwood, hardwood, plywood and wood-based panels.



**Machines**

Hand-held routers, table routers.



ORDER NO.	C.D.	S.D.	C.L.	Z	PRICE
TT.PB.12620	12	6	20	2	1090
TT.PB.16625	16	6	25	2	1270
TT.PB.19625	19	6	25	2	1315
TT.PB.16825	16	8	25	2	1270
TT.PB.19825	19	8	25	2	1315
TT.PB.22825	22	8	25	2	1495

\*Special sizes available as per customer needs.

\*Also available in Replaceable Knives.

\*Also available in PCD



## TCT Brazed Straight Clean Bottom Bit - TT.SB

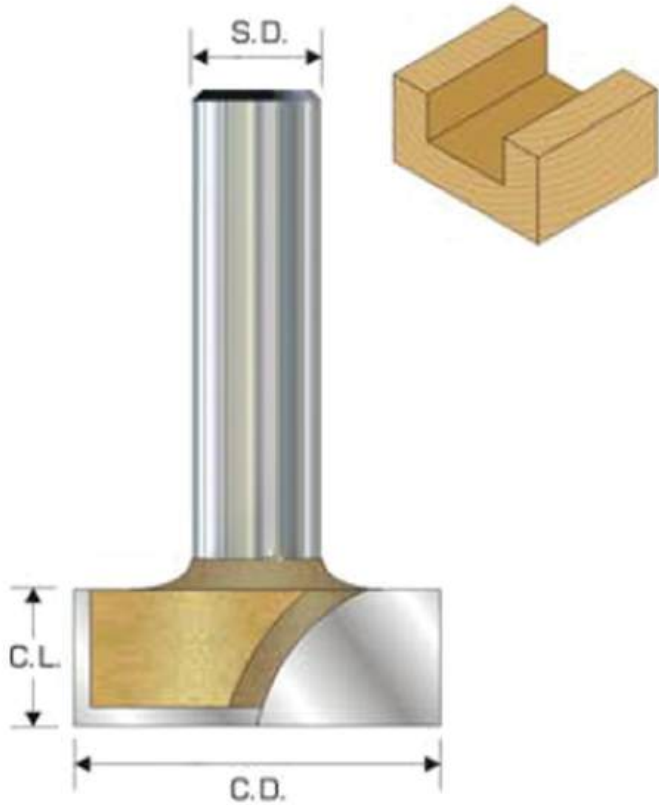

### Application

Ideal for grooving, edge-routing, plunge cuts and other general purpose routing tasks. The additional centred tip provides a smoother plunge cut with a clean bottom finish.

### Materials

Softwood, hardwood, plywood and wood-based panels.



### Machines

Hand-held routers, table routers and CNC machines.

ORDER NO.	C.D.	S.D.	C.L.	Z	PRICE
TT.SB.101212	10	12	12	2	757
TT.SB.121212	12	12	12	2	883
TT.SB.151215	15	12	15	2	847
TT.SB.161215	16	12	15	2	937
TT.SB.181215	18	12	15	2	937
TT.SB.191215	19	12	15	2	937
TT.SB.201215	20	12	15	2	1036
TT.SB.221215	22	12	15	2	1036
TT.SB.251215	25	12	15	2	1036
TT.SB.281215	28	12	15	2	1126
TT.SB.301215	30	12	15	2	1126
TT.SB.321215	32	12	15	2	1225
TT.SB.351215	35	12	15	2	1225
TT.SB.381215	38	12	15	2	1405
TT.SB.401215	40	12	15	2	1594
TT.SB.451215	45	12	15	2	1684
TT.SB.501215	50	12	15	2	1783



\*Special sizes available as per customer needs.

\*Also available in Replaceable Knives.

\*Also available in PCD



**TCT Brazed Flush Trim Bit - TT.TB**

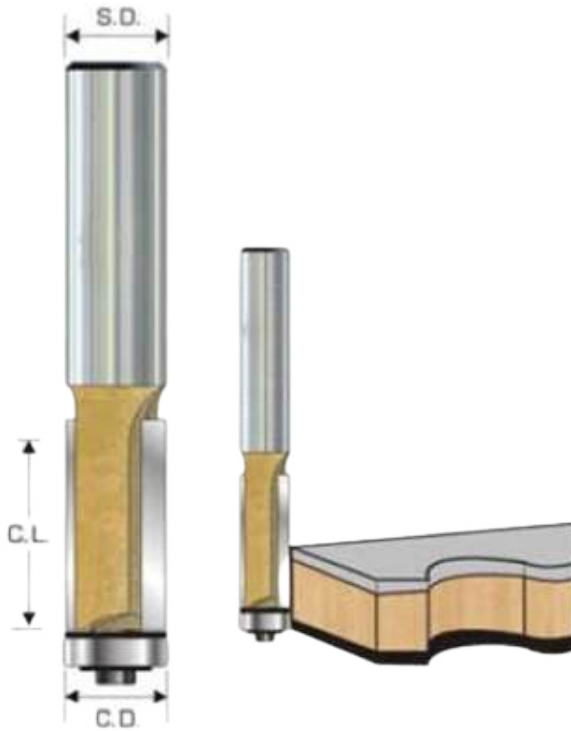

**Application**

Use these bits for precise trim work on laminated counter tops, to follow patterns and to create or duplicate complex shapes.

**Materials**

Hardwood, softwood, plywood, laminated, and wood composites.



**Machines**

Hand-held routers, table routers and CNC machines.



ORDER NO.	C.D.	C.L.	S.D.	Z	PRICE
TT.TB.6206	6.35	20	6	2	667
TT.TB.6208	6.35	20	8	2	730
TT.TB.62012	6.35	20	12	2	730
TT.TB.9256	9.52	25	6	2	766
TT.TB.9258	9.52	25	8	2	766
TT.TB.93012	9.52	30	12	2	847
TT.TB.95012	9.52	50	12	2	1612
TT.TB.12256	12.7	25	6	2	883
TT.TB.12308	12.7	30	8	2	883
TT.TB.123012	12.7	30	12	2	883
TT.TB.123812	12.7	38	12	2	1000
TT.TB.125012	12.7	50	12	2	1684
TT.TB.126512	12.7	65	12	2	3070
TT.TB.127512	12.7	75	12	2	3223

\*Special sizes available as per customer needs.

\*Also available in Replacable Knives.

\*Also available in PCD



## TCT Brazed Flush Trim Bit – Eco Range

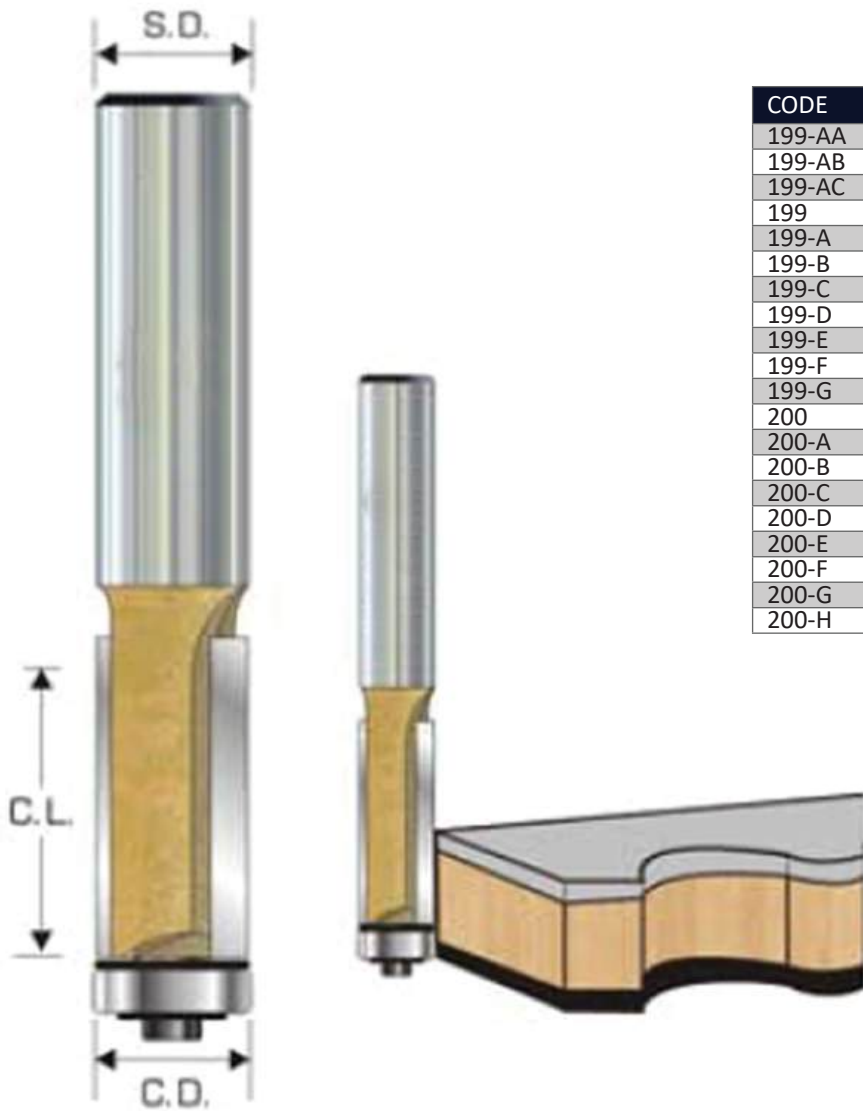

CODE	C.D.	S.D.	C.L.	PRICE
199-AA	6.35(1/4")	6	20	352
199-AB	6.35(1/4")	6.35	20	352
199-AC	6.35(1/4")	8	20	352
199	9.52(3/8")	8	30	373
199-A	9.52(3/8")	12	30	460
199-B	9.52(3/8")	6	20	352
199-C	9.52(3/8")	6.35	20	352
199-D	9.52(3/8")	8	38	505
199-E	9.52(3/8")	12	38	505
199-F	9.52(3/8")	8	50	829
199-G	9.52(3/8")	12	50	829
200	12.70(1/2")	8	30	370
200-A	12.70(1/2")	12	30	460
200-B	12.70(1/2")	12.70	30	460
200-C	12.70(1/2")	6	20	370
200-D	12.70(1/2")	6.35	20	370
200-E	12.70(1/2")	8	38	622
200-F	12.70(1/2")	12	38	622
200-G	12.70(1/2")	8	50	919
200-H	12.70(1/2")	12	50	919



\*Special sizes available as per customer needs.

\*Also available in Replaceable Knives.

\*Also available in PCD



**TCT Brazed Pointed “V” Groove Bit - TT.VG**

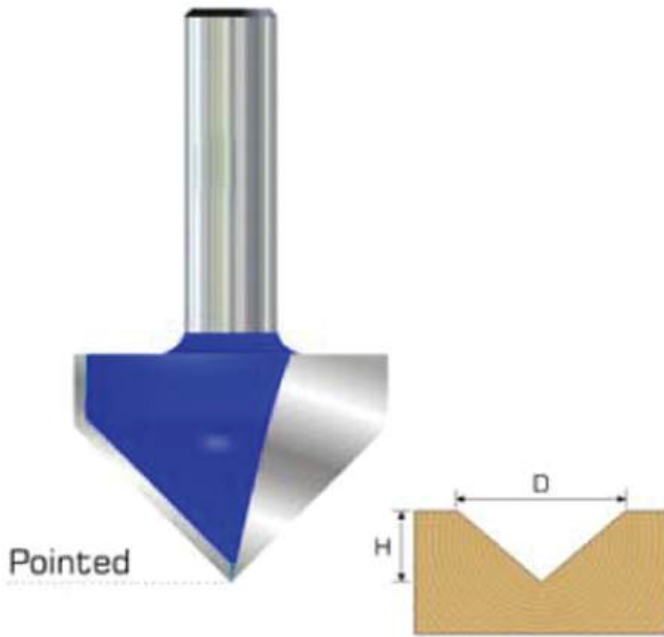

**Application**  
 Perfect for V shaped grooves, sign-making, engraving and decorative details.

**Materials**  
 Hardwood, softwood, plywood, laminated, and wood composites.



**Machines**  
 Hand-held routers, table routers and CNC machines.

ORDER NO.	C.D.	DEGREE	H	S.D.	PRICE
TT.VG.12.60.8	12	60	10	8	730
TT.VG.12.90.8	12	90	6	8	730
TT.VG.12.120.8	12	120	3.5	8	730
TT.VG.15.60.8	15	60	13	8	937
TT.VG.15.90.8	15	90	7.5	8	937
TT.VG.19.60.8	19	60	16.5	8	1126
TT.VG.19.60.12	19	60	16.5	12	1126
TT.VG.19.90.8	19	90	9.5	8	1126
TT.VG.19.90.12	19	90	9.5	12	1126
TT.VG.25.90.8	25	90	12.5	8	1315
TT.VG.25.90.12	25	90	12.5	12	1315
TT.VG.32.90.8	32	90	16	8	1684
TT.VG.32.90.12	32	90	16	12	1684
TT.VG.32.120.8	32	120	9	8	1684
TT.VG.32.120.12	32	120	9	12	1684
TT.VG.32.140.12	32	140	5.5	12	1684

\*Special sizes available as per customer needs.  
 \*Also available in Replaceable Knives.  
 \*Also available in PCD



## TCT Brazed "V" Groove Bit - TT.AVG



### Application

Designed to create a V groove on ACM panels, ensuring an easy bending of the panel without fractures.

### Materials

ACM (Aluminium Composite Material) panels, soft-wood, hardwood, plywood and wood-based panels.



### Machines

Hand-held routers, table routers and CNC machines.



ORDER NO.	C.D.	DEGREE	H	S.D.	PRICE
TT.AVG.12.90.8	12	90	4.5	8	847
TT.AVG.12.135.8	12	135	2	8	847
TT.AVG.15.90.8	15	90	6	8	1036
TT.AVG.15.90.12	15	90	6	12	1036
TT.AVG.15.135.8	15	135	3	8	1036
TT.AVG.15.135.12	15	135	3	12	1036
TT.AVG.19.90.8	19	90	8	8	1225
TT.AVG.19.90.12	19	90	8	12	1225
TT.AVG.19.135.8	19	135	3.5	8	1225
TT.AVG.19.135.12	19	135	3.5	12	1225

\*Special sizes available as per customer needs.

\*Also available in Replaceable Knives.

\*Also available in PCD



**TCT Brazed Corner Radius Bit - TT.CR**

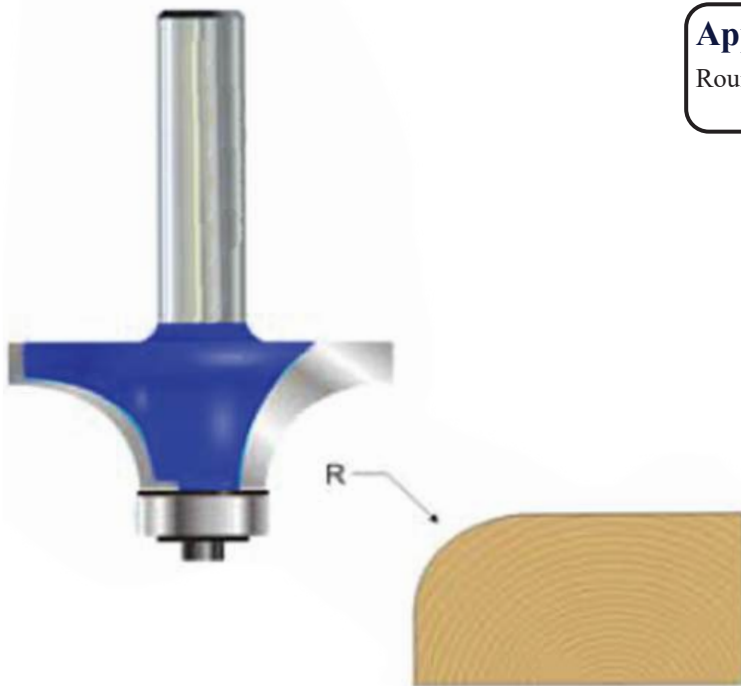

**Application**

Rounding over bits soften sharp edges of any workpiece.

**Materials**

Softwood, hardwood, plywood and wood-based panels.



**Machines**

Hand-held routers and table routers.

ORDER NO.	RADIUS	H	C.D.	S.D.	PRICE
TT.CR2.006	2R	7	16.7	6	730
TT.CR2.635	2R	7	16.7	6.35	730
TT.CR2.008	2R	7	16.7	8	730
TT.CR3.006	3R	8	18.7	6	730
TT.CR3.635	3R	8	18.7	6.35	730
TT.CR3.008	3R	8	18.7	8	730
TT.CR4.006	4R	10	20.7	6	937
TT.CR4.008	4R	10	20.7	8	937
TT.CR6.008	6R	11	24.7	8	1126
TT.CR9.008	9R	14	30.7	8	1315
TT.CR9.012	9R	14	30.7	12	1315
TT.CR12.08	12R	17	36.7	8	1495
TT.CR12.12	12R	17	36.7	12	1495
TT.CR16.12	16R	21	44.7	12	1873
TT.CR19.12	19R	25	50.7	12	2251
TT.CR25.12	25R	31	62.7	12	2629

\*Special sizes available as per customer needs.

\*Also available in Replacable Knives.

\*Also available in PCD



## TCT Brazed Beading Flat Bit - TT.BF

### Application

Designing Profiles.

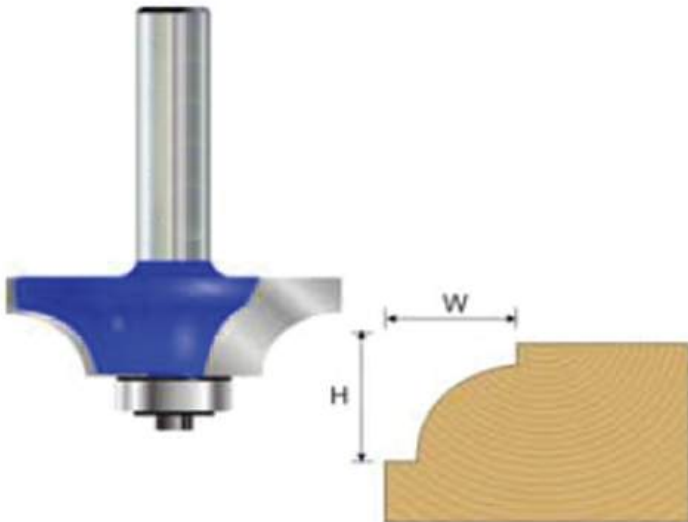

### Materials

Softwood, hardwood, plywood and wood-based panels.

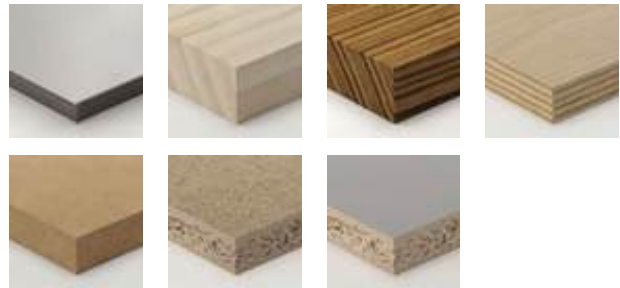

### Machines

Hand-held routers, table routers and CNC Machines.

ORDER NO.	W	H	C.D.	SHANK	Z	PRICE
TT.BF.08.08	8	8	29	12	2	937
TT.BF.10.10	10	10	33	12	2	1126
TT.BF.12.12	12	12	37	12	2	1225
TT.BF.15.10	15	10	43	12	2	1315
TT.BF.15.15	15	15	43	12	2	1405
TT.BF.19.19	19	19	51	12	2	1495

\*Special sizes available as per customer needs.

\*Also available in Replaceable Knives.

\*Also available in PCD



**TCT Brazed Rebating Bit - TT.RB**

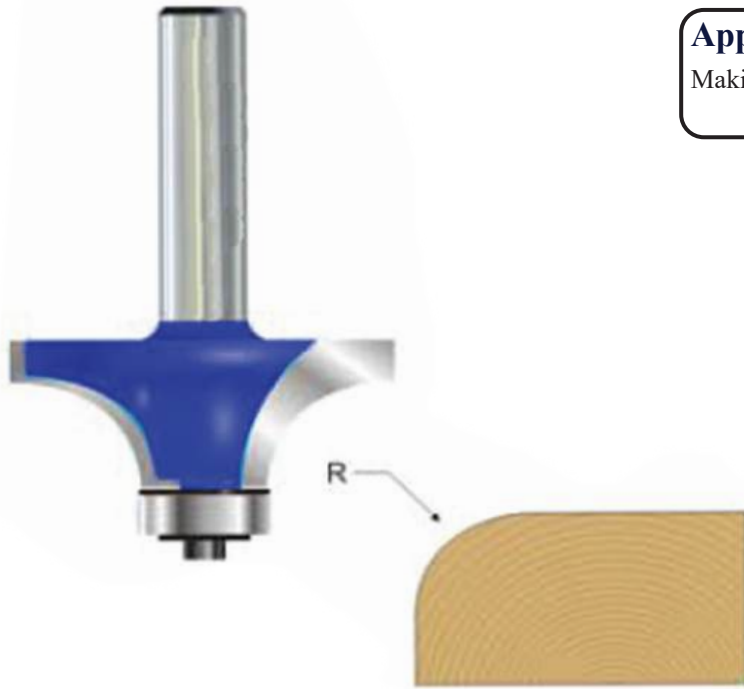

**Application**  
Making Rebates.

**Materials**

Softwood, hardwood, plywood and wood-based panels.



**Machines**  
Hand-held routers, table routers and CNC Machines.

ORDER NO.	W	H	C.D.	SHANK	Z	PRICE
TT.RB.04.12	4	12	37	12	4	1126
TT.RB.06.12	6	12	37	12	4	1126
TT.RB.08.12	8	12	37	12	4	1126
TT.RB.10.12	10	12	37	12	4	1225
TT.RB.12.12	12	12	37	12	4	1225
TT.RB.15.12	15	12	37	12	4	1495

\*Special sizes available as per customer needs.

\*Also available in Replaceable Knives.

\*Also available in PCD



## TCT Brazed Chamfer Bit - TT.CF

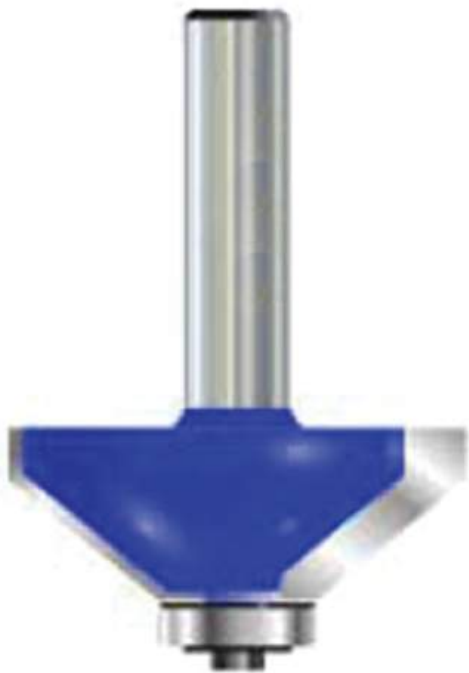

**Application**  
Making chamfer on workpiece.

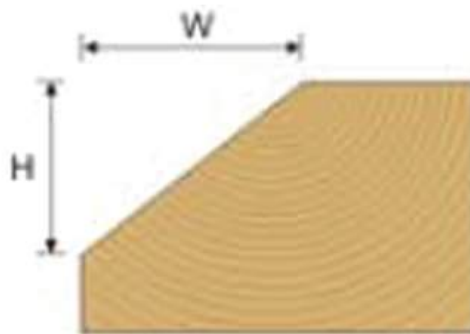

**Machines**  
Hand-held routers, table routers and CNC Machines.



**Materials**  
Softwood, hardwood, plywood and wood-based panels



ORDER NO.	W	H	C.D.	SHANK	Z	PRICE
TT.CF.6.6.6	6	6	25.4	6	2	1225
TT.CF.6.6.8	6	6	25.4	8	2	1225
TT.CF.10.10	10	10	33	12	2	1225
TT.CF.12.12	12	12	37	12	2	1225
TT.CF.15.15	15	15	43	12	2	1315
TT.CF.19.19	19	19	51	12	2	1405
TT.CF.22.22	22	22	57	12	2	1495
TT.CF.25.25	25	25	63	12	2	1783

\*Special sizes available as per customer needs.

\*Also available in Replaceable Knives.

\*Also available in PCD



**TCT Brazed Ovolo Point Bits - TT.OP**



**Application**

Making ovolo design on workpiece.

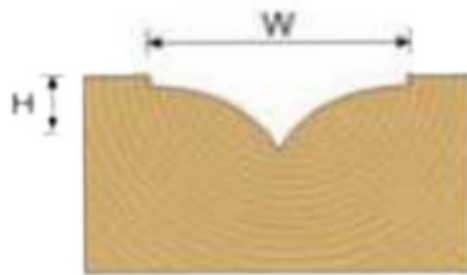

**Machines**

Hand-held routers, table routers and CNC Machines.



**Materials**

Softwood, hardwood, plywood and wood-based panels



ORDER NO.	W	H	C.D.	SHANK	Z	PRICE
TT.OP.12.08	12	8	12	12	2	847
TT.OP.15.08	15	8	15	12	2	937
TT.OP.19.10	19	10	19	12	2	937
TT.OP.22.10	22	10	22	12	2	1126
TT.OP.25.10	25	10	25	12	2	1126
TT.OP.32.12	32	12	32	12	2	1225

\*Special sizes available as per customer needs.

\*Also available in Replaceable Knives.

\*Also available in PCD



## TCT Brazed Rebating and Planning Bits - TT.RP

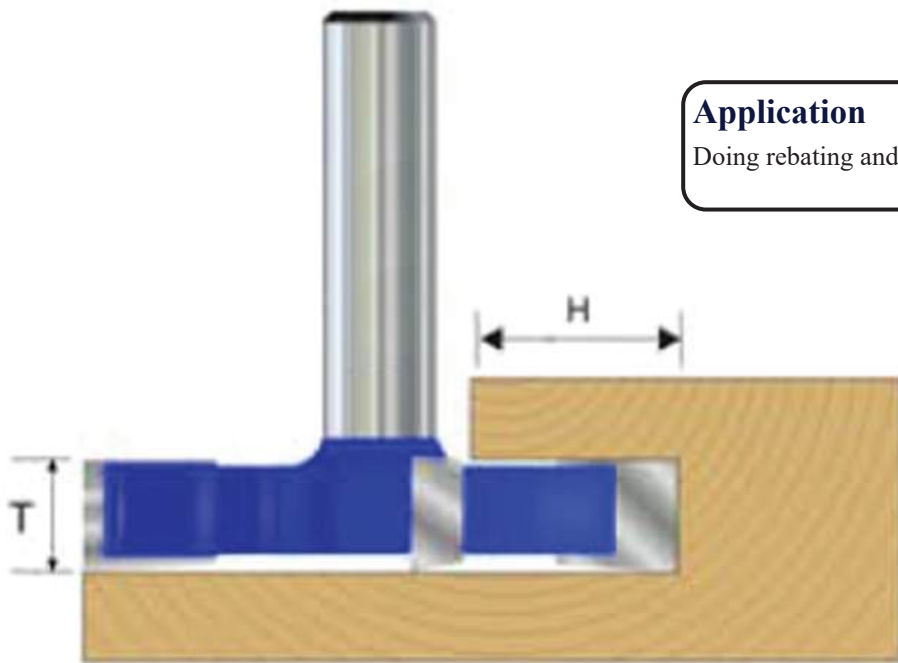

### Application

Doing rebating and planning in workpiece.

### Machines

Hand-held routers, table routers and CNC Machines.



### Materials

Softwood, hardwood, plywood and wood-based panels



ORDER NO.	DIA.	T	H	SD	Z	PRICE
TT.RP.4506	45	6	15	12	2	2161
TT.RP.4508	45	8	15	12	2	2341
TT.RP.4510	45	10	15	12	2	2629
TT.RP.4512	45	12	15	12	2	2818
TT.RP.5506	55	6	19	12	2	3097
TT.RP.5508	55	8	19	12	2	3187
TT.RP.5510	55	10	19	12	2	3286
TT.RP.5512	55	12	19	12	2	3376
TT.RP.6506	65	6	25	12	2	3565
TT.RP.6508	65	8	25	12	2	3655
TT.RP.6510	65	10	25	12	2	3754
TT.RP.6512	65	12	25	12	2	3943

\*Special sizes available as per customer needs.

\*Also available in Replaceable Knives.

\*Also available in PCD



**TCT Brazed T-Slotting Bits - TT.TP**



**Application**  
Making T-Slots in workpiece.

**Materials**

Softwood, hardwood, plywood and wood-based panels



**Machines**  
Hand-held routers, table routers and CNC Machines.



ORDER NO.	D1	D2	H1	H2	SD	PRICE
TT.TS.102	29	11	16	8	12	2629

\*Special sizes available as per customer needs.

\*Also available in PCD.



## TCT Brazed Hole Saw Bits - TT.HS

### Application

To make holes in work piece.



### Materials

Softwood, hardwood, plywood and wood-based panels



### Machines

Hand drill and Stand Drill Type Machine.

ORDER NO.	D	DEPTH	SHANK	Z	PRICE
TT.HS.35.12	35	28	12	6	1783
TT.HS.40.12	40	28	12	6	1972
TT.HS.45.12	45	28	12	6	2251
TT.HS.50.12	50	28	12	8	2440
TT.HS.55.12	55	28	12	8	2728
TT.HS.60.12	60	28	12	8	2820
TT.HS.63.12	63.5	28	12	8	3187
TT.HS.65.12	65	28	12	10	3286
TT.HS.70.12	70	28	12	10	3475
TT.HS.75.12	75	28	12	10	3664
TT.HS.80.12	80	28	12	10	3943

\*Special sizes available as per customer needs.

\*Also available in PCD.



**TCT Brazed Router Bits Set for Handle Less Shutters & Drawer- TT.HLR**

**Application**

To make handle less shutter and drawers.

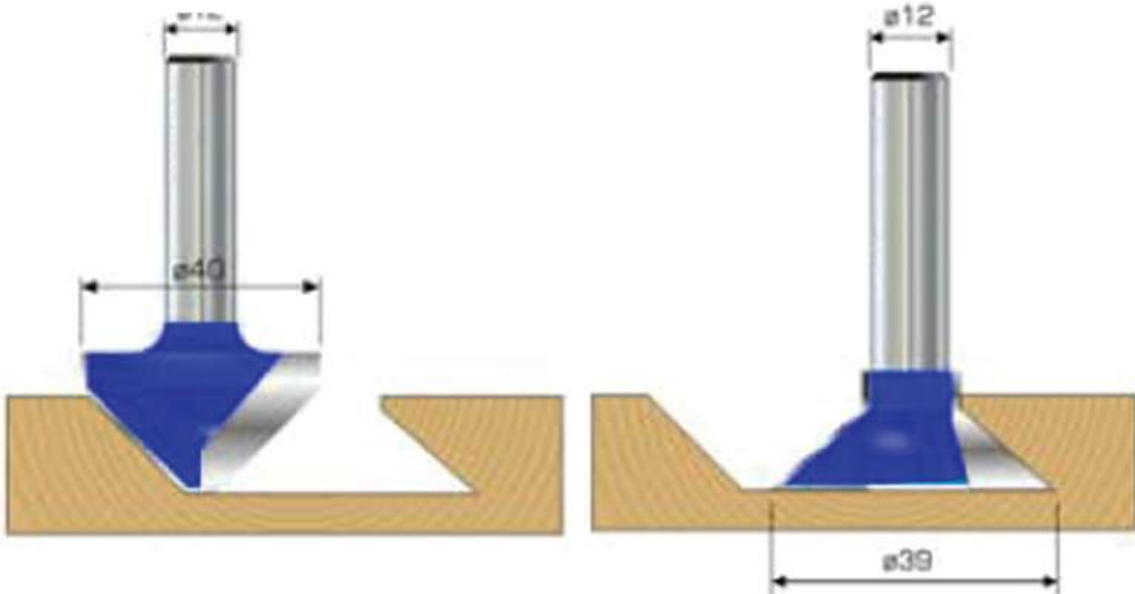

**Materials**

Softwood, hardwood, plywood and wood-based panels



**Machines**

Hand-held routers, table routers and CNC Machines.

ORDER NO.	D	SHANK	BOARD	Z	PRICE
TT.HLR.35.32.18	39/40	12	18	2	7507

\*Special sizes available as per customer needs.

\*Also available in PCD.



## TCT Brazed Router Bits Set for Handle Less Shutters & Drawer- TT.HLR

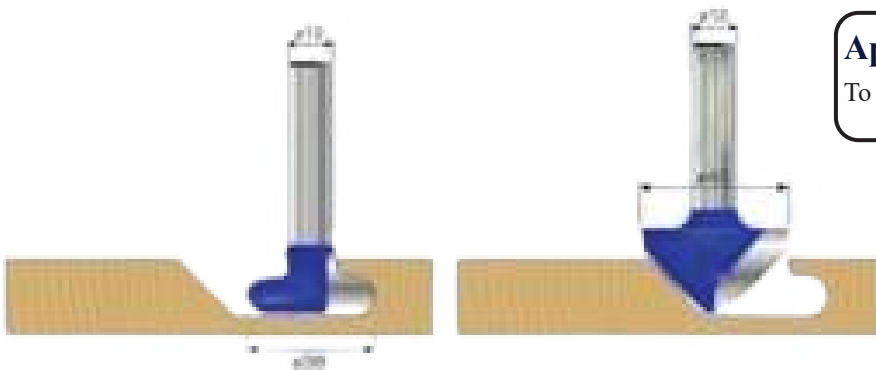

### Application

To make handle less shutter and drawers.

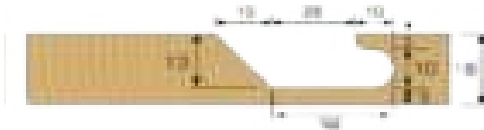

### Materials

Softwood, hardwood, plywood and wood-based panels



### Machines

Hand-held routers, table routers and CNC Machines.



ORDER NO.	DIA.	SHANK	BOARD	Z	PRICE
TT.HLR.35.38.20	38/40	12	18	2	7507

\*Special sizes available as per customer needs.

\*Also available in PCD.



**TCT Brazed Two Flute Dovetail Bits- TT.DT**



**Application**

To make beautifully crafted dovetail joint is a classic that appeals to both professionals and novices alike for its attractiveness in box and exposed joint projects. The dovetail joints are remarkably strong and functional.

**Materials**

Softwood, hardwood, plywood and wood-based panels



**Machines**

Hand-held routers, table routers and CNC Machines.

ORDER NO.	C.D.	HEIGHT	DEGREE	S.D.	PRICE
TT.DT.2F.12.7	12.7	12.7	14°	12	1315
TT.DT.2F.15.8	15.8	14.5	14°	12	1684
TT.DT.2F.19.0	19.0	19.0	14°	12	2251
TT.DT.2F.25.4	25.4	26.0	14°	12	2440
TT.DT.2F.13.8	13.8	14.0	10°	12	1720



ORDER NO.	C.D.	HEIGHT	DEGREE	S.D.	PRICE
TT.DT.1F.14.0	14	16	9	12	1720

ORDER NO.	C.D.	HEIGHT	DEGREE	THREAD	ROTATION	PRICE
TT.DT.3F.15 R	15	13.8	14	M 3/8	RIGHT	2998
TT.DT.3F.15 L	15	13.8	14	M 3/8	LEFT	2998

\*Special sizes available as per customer needs.

\*Also available in PCD.



## HSS Slot Mortising Drill Bit - TT.HS



### Application

Used for cutting mortise slots in soft and hardwood.

### Materials

Softwood, hardwood.



### Machines

Mortising machine equipped with chucks.

ORDER NO.	C.D.	C.L.	O.A.L.	S.D.	Z	PRICE
TT.HS.06.40.2	6	40	100	12/13	2	1720
TT.HS.08.50.2	8	50	100	12/13	2	1810
TT.HS.10.60.2	10	60	100	12/13	2	1900
TT.HS.12.60.2	12	60	100	12/13	2	1900
TT.HS.13.60.2	13	60	100	12/13	2	1900
TT.HS.14.60.2	14	60	100	12/13	2	1990
TT.HS.15.60.2	15	60	100	12/13	2	1990
TT.HS.16.60.2	16	60	100	12/13	2	2170
TT.HS.18.60.2	18	60	100	12/13	2	3250
TT.HS.19.60.2	19	60	100	12/13	2	3700
TT.HS.20.60.2	20	60	100	12/13	2	4600

ORDER NO.	C.D.	C.L.	O.A.L.	S.D.	Z	PRICE
TT.HS.06.40.3	6	40	100	16	3	1810
TT.HS.08.50.3	8	50	100	16	3	1810
TT.HS.10.60.3	10	60	100	16	3	1810
TT.HS.12.60.3	12	60	100	16	3	1900
TT.HS.13.60.3	13	60	100	16	3	1990
TT.HS.14.60.3	14	60	100	16	3	2460
TT.HS.15.60.3	15	60	100	16	3	2800
TT.HS.16.60.3	16	60	100	16	3	2800
TT.HS.18.60.3	18	60	100	16	3	3250
TT.HS.19.60.3	19	60	100	16	3	3700
TT.HS.20.60.3	20	60	100	16	3	4600

\*Special sizes available as per customer needs.

\*Also available in PCD.



**Two Flute Solid Carbide Spiral Bit (End Mill) – TT.TFS**



**Application**

Used for Ripping, Template Routing, Panel Sizing & Through and Blind Cutting Application.

**Materials**

Softwood, hardwood, plywood, wood-based panels, plastic material and laminates.



**Machines**

CNC machines.

ORDER NO.	C.D.	S.D.	C.L.	O.A.L.	Z	PRICE
TT.TFS.02.12	2	3	12	50	2	370
TT.TFS.03.15	3	3	15	50	2	424
TT.TFS.04.20	4	4	20	55	2	487
TT.TFS.05.20	5	5	20	60	2	658
TT.TFS.06.22	6	6	22	60	2	847
TT.TFS.08.30	8	8	30	65	2	1315
TT.TFS.10.30	10	10	30	70	2	2062
TT.TFS.12.30	12	12	30	75	2	2728
TT.TFS.14.50	14	14	50	100	2	5257
TT.TFS.16.50	16	16	50	100	2	6400
TT.TFS.18.50	18	18	50	100	2	7885
TT.TFS.20.50	20	20	50	100	2	8992

ORDER NO.	C.D.	S.D.	C.L.	O.A.L.	Z	PRICE
TT.TFS.DC.03.15	3	3	15	55	2	568
TT.TFS.DC.04.20	4	4	20	60	2	757
TT.TFS.DC.05.20	5	5	20	60	2	937
TT.TFS.DC.06.22	6	6	22	65	2	1126
TT.TFS.DC.08.30	8	8	30	70	2	1783
TT.TFS.DC.10.30	10	10	30	70	2	2440
TT.TFS.DC.12.30	12	12	30	75	2	3196

\*Special sizes available as per customer needs.

\*Also available in PC.D.



## Two Flute Solid Carbide Ball Nose Bit (End Mill) – TT.TFB



### Application

Can be used for carving and producing a smooth edge cut on workpiece.

### Materials

Softwood, hardwood, plywood, wood-based panels, plastic material and laminates.



### Machines

CNC machines.

ORDER NO.	C.D.	S.D.	C.L.	O.A.L.	Z	PRICE
TT.TFB.03.15	3	3	15	50	2	424
TT.TFB.04.20	4	4	20	55	2	487
TT.TFB.05.20	5	5	20	60	2	658
TT.TFB.06.20	6	6	20	60	2	847
TT.TFB.08.20	8	8	20	65	2	1315
TT.TFB.10.30	10	10	30	70	2	2062
TT.TFS.12.30	12	12	30	75	2	2728

ORDER NO.	C.D.	S.D.	C.L.	O.A.L.	Z	PRICE
TT.TFB.03.20	3	3	20	65	2	658
TT.TFB.04.25	4	4	25	75	2	937
TT.TFB.05.25	5	5	25	75	2	1126
TT.TFB.06.30	6	6	30	75	2	1396
TT.TFB.06.40	6	6	40	100	2	1684
TT.TFB.06.50	6	6	50	150	2	2530
TT.TFS.08.30	8	8	30	75	2	1873
TT.TFB.08.40	8	8	40	100	2	1972
TT.TFB.08.50	8	8	50	150	2	3943

\*Special sizes available as per customer needs.

\*Also available in PCD.



**Two Flute Solid Carbide Straight Bit – TT.ST**



**Application**

Can be used for through and blind cutting, rebating, grooving, trimming & copying of raw material.

**Materials**

Softwood, hardwood, plywood, wood-based panels, plastic material and laminates.



ORDER NO.	C.D.	S.D.	C.L.	O.A.L.	Z	PRICE
TT.ST.4.4.15	4	4	15	55	2	568
TT.ST.4.4.20	4	4	20	55	2	568
TT.ST.4.6.20	4	6	20	60	2	757
TT.ST.5.6.25	5	6	25	60	2	847
TT.ST.5.8.25	5	8	25	65	2	1315
TT.ST.6.6.20	6	6	20	60	2	847
TT.ST.6.6.25	6	6	25	60	2	847
TT.ST.6.6.30	6	6	30	60	2	937
TT.ST.6.6.40	6	6	40	75	2	1126
TT.ST.6.8.25	6	8	25	65	2	1225
TT.ST.8.8.25	8	8	25	65	2	1315
TT.ST.8.8.30	8	8	30	65	2	1315
TT.ST.8.8.40	8	8	40	75	2	1684
TT.ST.8.8.50	8	8	50	100	2	1972
TT.ST.10.10.30	10	10	30	70	2	2062
TT.ST.10.10.40	10	10	40	75	2	2629
TT.ST.10.10.50	10	10	50	100	2	2998
TT.ST.10.10.75	10	10	75	150	2	4699
TT.ST.12.12.30	12	12	30	75	2	2818
TT.ST.12.12.40	12	12	40	75	2	2998
TT.ST.12.12.50	12	12	50	100	2	3754
TT.ST.12.12.75	12	12	75	150	2	5995

**Machines**

CNC machines.



\*Special sizes available as per customer needs.

\*Also available in PCD.



## Straight Bits with Solid Carbide Insert (Steel Shank)– TT.INS



### Application

Provide smooth finished cut on work piece.

### Materials

ACP, Acrylic, Plastics, Laminated Panel.

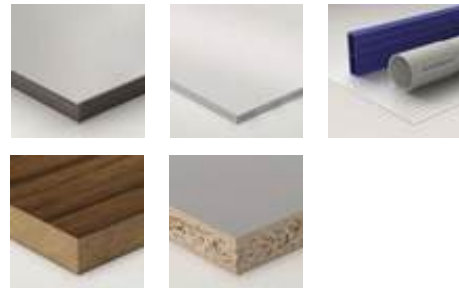

### Machines

CNC machines.



ORDER NO.	C.D.	S.D.	C.L.	O.A.L	Z	PRICE
TT.INS.02.6.6	2	6	6	45	1	469
TT.INS.02.6.8	2	8	6	45	1	469
TT.INS.03.8.6	3	6	8	50	2	487
TT.INS.03.8.8	3	8	8	50	2	577
TT.INS.03.15.6	3	6	15	60	2	577
TT.INS.03.15.8	3	8	15	60	2	577
TT.INS.03.10.12	3	12	10	50	2	577
TT.INS.04.12.6	4	6	12	55	2	613
TT.INS.04.12.8	4	8	12	55	2	613
TT.INS.04.20.8	4	8	20	60	2	703
TT.INS.04.15.12	4	12	15	55	2	703
TT.INS.04.20.12	4	12	20	60	2	730
TT.INS.06.25.12	6	12	25	65	2	937
TT.INS.08.30.12	8	12	30	75	2	1738

\*Special sizes available as per customer needs.

\*Also available in PCD.



**HSS Single Flute Spiral Bit for Aluminium Cutting– TT.AL**



**Application**

For effective carving on all types of aluminium.

**Materials**

Aluminium and PVC Windows and Doors.

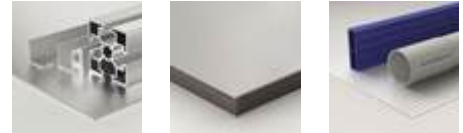

**Machines**

Copy Routers and CNC machines.



ORDER NO.	C.D.	C.L.	N.C.	O.A.L.	S.D.	PRICE
TT.AL.5.25.80	5	25		80	8	2251
TT.AL.5.14.125	5	14	65	125	8	2998
TT.AL.6.14.80	6	14		80	8	1684
TT.AL.8.14.80	8	14		80	8	1495
TT.AL.10.14.80	10	14		80	8	2062

\*Special sizes available as per customer needs.

\*Also available in PCD.



**Solid Carbide Engraving Router bit– T.T.EG**



**Application**

Used for engraving of workpiece.

**Materials**

Solid Wood, Melamine Board, MDF & Laminated Plyboard.



**Machines**

CNC machines.

ORDER NO.	C.D.	S.D.	C.L.	O.A.L.	Z	PRICE
TT.EG.04.30	4	4	30	55	1	568
TT.EG.04.60	4	4	60	55	1	568
TT.EG.06.30	6	6	30	60	1	937
TT.EG.06.60	6	6	60	60	1	937
TT.EG.08.30	8	8	30	65	1	1315

\*Special sizes available as per customer needs.



**Solid Carbide Tapered Ball Nose Spiral Bit– TT.TBS**



**Application**

To be used on all CNC router for raw material.

**Materials**

Solid Wood, Melamine Board, MDF & Laminated Plyboard.



**Machines**

CNC machines.

ORDER NO.	C.D.	S.D.	C.L.	O.A.L.	Z	PRICE
TT.TBS.01.35.6	1	6	35	75	2	1126
TT.TBS.02.35.6	2	6	35	75	2	1126
TT.TBS.02.35.8	2	8	35	75	2	1693
TT.TBS.03.35.6	3	6	35	75	2	1126
TT.TBS.03.35.8	3	8	35	75	2	1693
TT.TBS.04.35.6	4	6	35	75	2	1126
TT.TBS.04.35.8	4	8	35	75	2	1693

\*Special sizes available as per customer needs.



## Solid Carbide Up Cut Spiral Bits with Chip-breaker– TT.CBU



### Application

To be used for ripping, template routing, panel sizing and any routing application on solid wood.

### Materials

Solid Wood



ORDER NO.	C.D.	S.D.	C.L.	O.A.L.	Z	PRICE
TT.CBU.08.22	8	8	22	65	3	3376
TT.CBU.08.32	8	8	32	70	3	3754
TT.CBU.10.32	10	10	32	70	3	4888
TT.CBU.10.42	10	10	42	90	3	5995
TT.CBU.10.52	10	10	52	100	3	6562
TT.CBU.12.32	12	12	32	75	3	6562
TT.CBU.12.42	12	12	42	90	3	7885
TT.CBU.12.52	12	12	52	100	3	8443
TT.CBU.14.42	14	14	42	100	3	10693
TT.CBU.14.52	14	14	52	100	3	11638
TT.CBU.16.42	16	16	42	100	3	11998
TT.CBU.16.52	16	16	52	100	3	12385
TT.CBU.16.62	16	16	62	100	3	15769
TT.CBU.18.52	18	18	52	100	3	14995
TT.CBU.18.75	18	18	75	130	3	20620
TT.CBU.20.52	20	20	52	100	3	19540
TT.CBU.20.75	20	20	75	130	3	25903
TT.CBU.20.102	20	20	102	150	3	26650

### Machines

CNC machines.



\*Special sizes available as per customer needs.

\*Also available in PCD.



**Solid Carbide Up Cut Spiral Bits with Chip-breaker for Locksets– TT.CBS**



**Application**

To be used for ripping, template routing, panel sizing and any routing application on workpiece.

**Materials**

Solid Wood, Wood Composite.



**Machines**

CNC machines.

ORDER NO.	C.D.	S.D.	C.L.	O.A.L.	Z	PRICE
TT.CBS.14.95	14	14	95	150	3	23464
TT.CBS.16.95	16	16	95	150	3	25336
TT.CBS.16.95.LH	16	16	95	150	3	27217
TT.CBS.16.120	16	16	120	170	3	30970
TT.CBS.16.120.LH	16	16	120	170	3	33787
TT.CBS.18.120	18	18	120	170	3	36604

\*Special sizes available as per customer needs.

\*Also available in PCD.



**Solid Carbide Up & Down Cut Spiral Bits – TT.UDS**



**Application**

To be used for cutting, copying, panel sizing and any routing application on workpiece.

**Materials**

Solid Wood, Wood Composites, Plastic Materials and Laminates.



**Machines**

CNC machines.

ORDER NO.	C.D.	S.D.	C.L.	O.A.L.	Z	PRICE
TT.UDS.08.22	8	8	22	80	2+2	2800
TT.UDS.08.32	8	8	32	80	2+2	2998
TT.UDS.10.32	10	10	32	80	2+2	4132
TT.UDS.10.42	10	10	42	90	2+2	4510
TT.UDS.12.32	12	12	32	90	2+2	5635
TT.UDS.12.42	12	12	42	90	2+2	6400
TT.UDS.12.52	12	12	52	100	2+2	6751
TT.UDS.16.55	16	16	55	110	2+2	12394
TT.UDS.18.55	18	18	55	110	2+2	15760
TT.UDS.20.55	20	20	55	120	2+2	20260



\*Special sizes available as per customer needs.

\*Also available in PCD.



**3 Flute Straight Bits with Solid Carbide Insert – TT.3F**



**Application**

To be used for ripping, template routing, panel sizing and through & blind cutting application on workpiece. Specially used for Nesting Application.

**Materials**

Solid Wood, MDF, Particle Board, Wood Composites, Plastic Materials and Laminates.



**Machines**

CNC machines.

ORDER NO.	C.D.	S.D.	C.L.	O.A.L.	Z	PRICE
TT.3F.662.12.7	6	12.7	22	70	3	1126
TT.3F.628.12.7	6	12.7	28	80	3	1495
TT.3F.822.12.7	8	12.7	22	70	3	1693
TT.3F.828.12.7	8	12.7	28	80	3	2062
TT.3F.1030.12.7	10	12.7	30	80	3	3376

ORDER NO.	C.D.	S.D.	C.L.	O.A.L.	Z	PRICE
TT.3F.662.12	6	12	22	70	3	1126
TT.3F.628.12	6	12	28	80	3	1495
TT.3F.822.12	8	12	22	70	3	1693
TT.3F.828.12	8	12	28	80	3	2062
TT.3F.1030.12	10	12	30	80	3	3376



\*Special sizes available as per customer needs.



## TCT Multi Boring Bits (Dowell Drills) – TTB.MB



### Application

To drill blind holes on workpiece.

### Materials

Solid Wood, MDF, Particle Board, Wood Composites, Plastic Materials and Laminates.



### Machines

Multi boring and CNC Boring Machines with adaptor or chuck.

ORDER NO.	D	OAL	CL	SHANK	PRICE
TTB.MB.370R/L	3	70	35	10X30	1540
TTB.MB.470R/L	4	70	35	10X30	730
TTB.MB.570R/L	5	70	35	10X30	640
TTB.MB.670R/L	6	70	35	10X30	667
TTB.MB.770R/L	7	70	35	10X30	730
TTB.MB.870R/L	8	70	35	10X30	730
TTB.MB.970R/L	9	70	35	10X30	820
TTB.MB.1070R/L	10	70	35	10X30	820
TTB.MB.1170R/L	11	70	35	10X30	910
TTB.MB.1270R/L	12	70	35	10X30	991
TTB.MB.1370R/L	13	70	35	10X30	1270
TTB.MB.1470R/L	14	70	35	10X30	1351
TTB.MB.1570R/L	15	70	35	10X30	1450

\*Special sizes available as per customer needs.

\*Also available in solid carbide.



**TCT Through Hole Bits (Dowell Drills) – TTB.TH**



**Application**

To drill through holes on workpiece.

**Materials**

Solid Wood, MDF, Particle Board, Wood Composites, Plastic Materials and Laminates.



**Machines**

Multi boring and CNC Boring Machines with adaptor or chuck.



ORDER NO.	D	OAL	CL	SHANK	PRICE
TTB.TH.370R/L	3	70	35	10X30	1630
TTB.TH.470R/L	4	70	35	10X30	910
TTB.TH.570R/L	5	70	35	10X30	820
TTB.TH.670R/L	6	70	35	10X30	910
TTB.TH.770R/L	7	70	35	10X30	910
TTB.TH.870R/L	8	70	35	10X30	910
TTB.TH.970R/L	9	70	35	10X30	1000
TTB.TH.1070R/L	10	70	35	10X30	1000
TTB.TH.1170R/L	11	70	35	10X30	1270
TTB.TH.1270R/L	12	70	35	10X30	1270
TTB.TH.1370R/L	13	70	35	10X30	1540
TTB.TH.1570R/L	15	70	35	10X30	1630

\*Special sizes available as per customer needs.

\*Also available in solid carbide.



## TCT Hinge Drill Bits – TTB.HB



### Application

To make holes for making hinges.

### Materials

Solid Wood, MDF, Particle Board, Wood Composites, Plastic Materials and Laminates.



### Machines

Multi boring and CNC Boring Machines with adaptor or chuck.

ORDER NO.	D	OAL	SHANK	PRICE
TTB.HB.15.70R/L	15	70	10X26	1270
TTB.HB.16.70R/L	16	70	10X26	1297
TTB.HB.18.70R/L	18	70	10X26	1360
TTB.HB.19.70R/L	19	70	10X26	1360
TTB.HB.20.70R/L	20	70	10X26	1360
TTB.HB.22.70R/L	22	70	10X26	1450
TTB.HB.25.70R/L	25	70	10X26	1450
TTB.HB.30.70R/L	10	70	10X26	1630
TTB.HB.35.70R/L	35	70	10X26	1720
TTB.HB.40.70R/L	40	70	10X26	2080
TTB.HB.50.70R/L	50.8	70	10X26	2710
TTB.HB.63.70R/L	63.5	70	10X26	3340



\*Special sizes available as per customer needs.



**TCT Counter Sunk for Multi Boring Bits – TTB.CS**

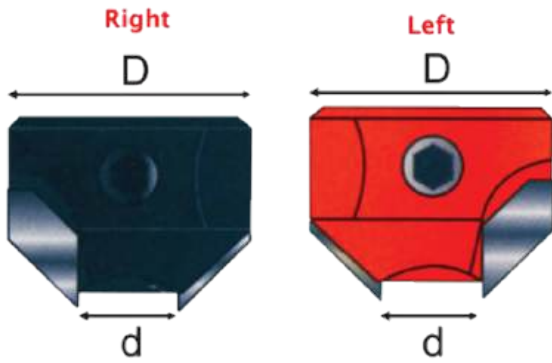

**Application**

Chamfering with hole in workpiece.

**Materials**

Solid Wood, MDF, Particle Board, Wood Composites, Plastic Materials and Laminates.



**Machines**

Multi boring and CNC Boring Machines



ORDER NO.	D	OUTER DIA	DEGREE	OAL	TEETH	PRICE
TTB.CS.04R/L	4	16	45°	16	2	1135
TTB.CS.05R/L	5	16	45°	16	2	1135
TTB.CS.06R/L	6	16	45°	16	2	1135
TTB.CS.07R/L	7	16	45°	16	2	1135
TTB.CS.08R/L	8	18	45°	16	2	1135
TTB.CS.09R/L	9	18	45°	16	2	1135
TTB.CS.10R/L	10	20	45°	16	2	1270
TTB.CS.12R/L	12	20	45°	16	2	1270

**Adaptor for Multi Boring Machines – TDP**

**Application**

Hold multi-boring bits.

**Machines**

Multi boring and CNC Boring Machines



ORDER NO.	D1	D2	D3	OAL	PRICE
TDP-101	19.4	10	14	40	550
TDP-102	18	10	12	42	640

\*Special sizes available as per customer needs.



## TCT Brazed Grooving Cutter – TTB.GC.01

### Application

Ideal tools to create precision grooving & rebating in jobs from 4mm to 38mm.

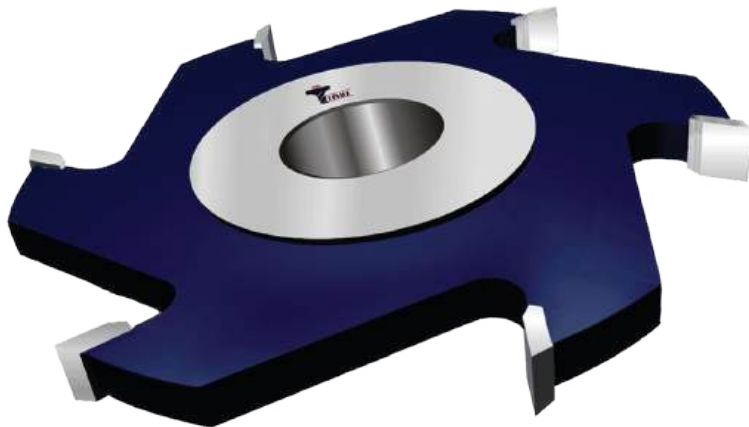

### Materials

Solid Wood, MDF, Particle Board, Plywood and Wood Composites.



### Machines

Spindle Moulder Machines, Double End Tenoners and Shaper Machines.

ORDER NO.	D	BORE	THICK	Z	PRICE
TTB.GC.01.404	100	30/35	4	6	1405
TTB.GC.01.406	100	30/35	6	6	1540
TTB.GC.01.408	100	30/35	8	6	1693
TTB.GC.01.409	100	30/35	9	6	1837
TTB.GC.01.410	100	30/35	10	6	1972
TTB.GC.01.412	100	30/35	12	6	2062
TTB.GC.01.415	100	30/35	15	6	3097
TTB.GC.01.418	100	30/35	18	6	3475
TTB.GC.01.420	100	30/35	20	6	3664
TTB.GC.01.422	100	30/35	22	6	3943
TTB.GC.01.425	100	30/35	25	6	4123
TTB.GC.01.430	100	30/35	30	6	5167
TTB.GC.01.435	100	30/35	35	6	5635
TTB.GC.01.438	100	30/35	38	6	6760



\* Also available in 125mm, 150mm and 200mm diameter.

\* Special Sizes available as per customer needs.

\* Also available in replaceable knives.

\* Also available in PCD.



**TCT Brazed Grooving Saw Blade for Panel Saw Machine – TTB.GC.02**

**Application**

Ideal tools to create precision slots and grooves.



**Materials**

Solid Wood, MDF, Particle Board, Plywood and Wood Composites.



**Machines**

Panel Saw Machine.

ORDER NO.	D	BORE	THICK	TOOTH TYPE	Z	PRICE
TTB.GC.02.6235	180	30	6.2	ZYZP	35	7507
TTB.GC.02.7235	180	30	7.2	ZYZP	35	8254
TTB.GC.02.8235	180	30	8.2	ZYZP	35	8821
TTB.GC.02.9235	180	30	9.2	ZYZP	35	10135
TTB.GC.02.1035	180	30	10.2	ZYZP	35	11260
TTB.GC.02.1135	180	30	11.2	ZYZP	35	11800
TTB.GC.02.1235	180	30	12.2	ZYZP	35	12952

\*Special Sizes available as per customer needs.

\* Also available in replaceable knives.

\* Also available in PCD.



## TCT Brazed Grooving Cutters for Panel Saw Machine – TTB.GC.02

### Application

Ideal tools to create precision slots and grooves.



### Materials

Solid Wood, MDF, Particle Board, Plywood and Wood Composites.



### Machines

Panel Saw Machine.

ORDER NO.	D	BORE	THICK	Z	PRICE
TTB.GC.02.6216	200	30	6.2	16	7886
TTB.GC.02.7216	200	30	7.2	16	7886
TTB.GC.02.8216	200	30	8.2	16	7886
TTB.GC.02.9216	200	30	9.2	16	7886
TTB.GC.02.1016	200	30	10.2	16	7886
TTB.GC.02.1116	200	30	11.2	16	7886
TTB.GC.02.1216	200	30	12.2	16	7886

\*Special Sizes available as per customer needs.

\* Also available in replaceable knives.

\* Also available in PCD.



**TCT Brazed Adjustable Grooving Cutters – TTB.AG.03**

**Application**

Ideal tools to create precision slots and grooves.



**Materials**

Solid Wood, MDF, Particle Board, Plywood and Wood Composites.



**Machines**

Spindle Moulder Machine, Double End Tenoners.

ORDER NO.	D	BORE	THICK	Z	PRICE
TTB.AG.03.0612	150	30/35	6-12	4+4	7885
TTB.AG.03.0815	150	30/35	8-15	4+4	8821
TTB.AG.03.1224	150	30/35	12-24	4+4	10324
TTB.AG.03.1529	150	30/35	15-29	4+4	11260

\*Special Sizes available as per customer needs.

\* Also available in replaceable knives.

\* Also available in PCD.



**TCT Brazed Half Radius Cutters – TTB.HR.05**



**Application**

Perfect radius & finish in all materials.

**Materials**

Solid Wood, MDF, Particle Board, Plywood and Wood Composites.



**Machines**

Spindle Moulder Machine & Shaper Machine.

ORDER NO.	D	BORE	BOARD THICK	RADIUS	Z	PRICE
TTB.HR.05.1809	125	30/35	18	9R	4	7138
TTB.HR.05.2512	125	30/35	25	12.5R	4	7885
TTB.HR.05.3015	125	30/35	30	15R	4	11260
TTB.HR.05.3618	125	30/35	36	18R	4	14266
TTB.HR.05.5025	140	30/35	50	25R	4	22528

\*Special Sizes available as per customer needs.

\* Also available in replaceable knives.

\* Also available in PCD.



**TCT Brazed Quarter Radius Cutters – TTB.QR.06**

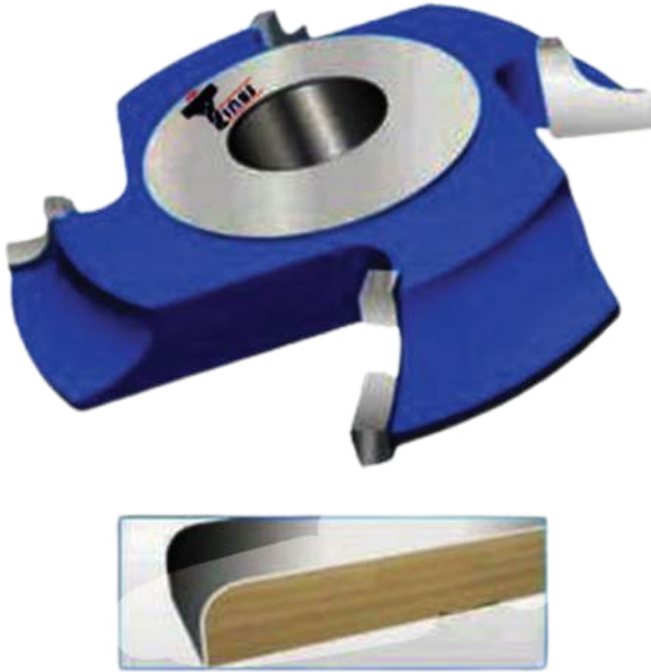

**Application**

Perfect radius & finish in all materials.

**Materials**

Solid Wood, MDF, Particle Board, Plywood and Wood Composites.



**Machines**

Spindle Moulder Machine & Shaper Machine.

ORDER NO.	D	BORE	BOARD THICK	RADIUS	Z	PRICE
TTB.QR.06.1802	125	30/35	18	R2	4	3196
TTB.QR.06.1803	125	30/35	18	R3	4	3196
TTB.QR.06.1804	125	30/35	18	R4	4	3196
TTB.QR.06.1806	125	30/35	18	R6	4	3475
TTB.QR.06.1809	125	30/35	18	R9	4	3943
TTB.QR.06.2512	125	30/35	25	R12	4	4411
TTB.QR.06.2515	125	30/35	25	R15	4	5635
TTB.QR.06.3618	125	30/35	36	R18	4	6850
TTB.QR.06.3525	140	30/35	35	R25	4	8542
TTB.QR.06.3535	150	30/35	35	R35	4	14455

\*Special Sizes available as per customer needs.

\* Also available in replaceable knives.

\* Also available in PCD.



**TCT Brazed Corner Radius with Straight Trim Cutters – TTB.CT.07**

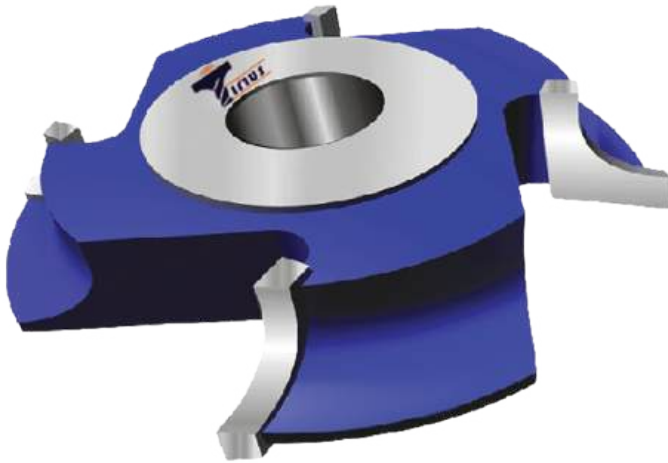

**Application**

Perfect radius with trim in all materials.

**Materials**

Solid Wood, MDF, Particle Board, Plywood and Wood Composites.

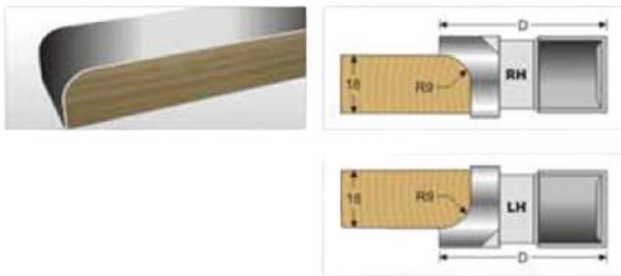

**Machines**

Spindle Moulder Machine & Shaper Machine.

ORDER NO.	D	BORE	BOARD THICK	RADIUS	Z	PRICE
TTB.CT.07.1809	125	30/35	18	R9	4	7696
TTB.CT.07.1812	125	30/35	18	R12	4	8443
TTB.CT.07.2512	125	30/35	25	R12	4	8911
TTB.CT.07.2515	125	30/35	25	R15	4	10414
TTB.CT.07.3618	125	30/35	36	R18	4	12205
TTB.CT.07.3625	125	30/35	36	R25	4	13420

\*Special Sizes available as per customer needs.

\* Also available in replaceable knives.

\* Also available in PCD.



**TCT Brazed Corner Edge Radius Cutters – TT.B.ER.08**

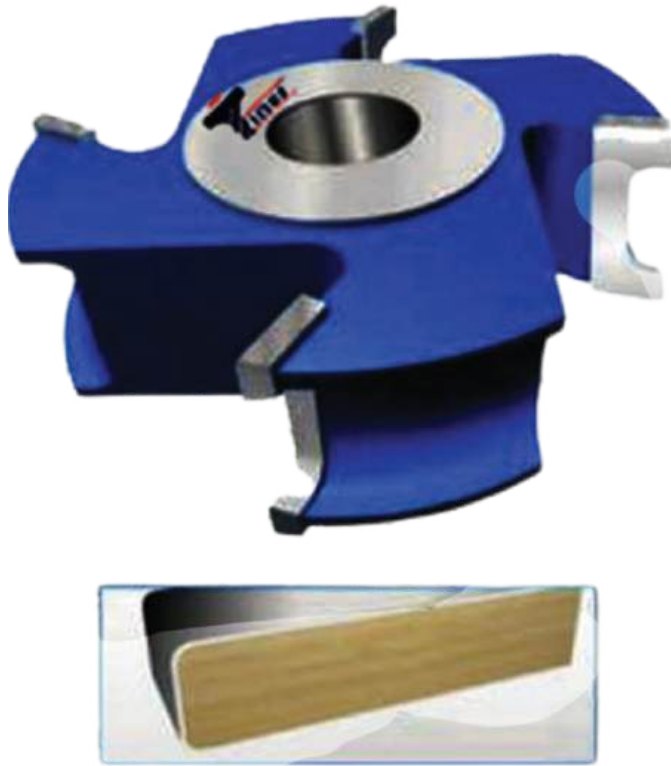

**Application**  
Perfect radius with trim in all materials.

**Materials**

Solid Wood, MDF, Particle Board, Plywood and Wood Composites.



**Machines**  
Spindle Moulder Machine & Shaper Machine.

ORDER NO.	D	BORE	BOARD THICK	RADIUS	Z	PRICE
TTB.ER.08.1804	125	30/35	18	R4	4	7696
TTB.ER.08.2504	125	30/35	25	R4	4	8911
TTB.ER.08.2506	125	30/35	25	R6	4	9667
TTB.ER.08.3006	125	30/35	30	R6	4	11638
TTB.ER.08.3606	125	30/35	36	R6	4	12574
TTB.ER.08.3609	125	30/35	36	R9	4	14176

- \*Special Sizes available as per customer needs.
- \* Also available in replaceable knives.
- \* Also available in PCD.



**TCT Brazed J Profile Cutters – TTB.HL**



**Application**

To make handle less shutters.

**Materials**

Solid Wood, MDF, Particle Board, Plywood and Wood Composites.



**Machines**

Spindle Moulder Machine & Shaper Machine.

ORDER NO.	D	BORE	BOARD THICK	PROFILE LENGTH	Z	PRICE
TTB.HL.JP.101	150	30/35	18	30-45	4	11260
TTB.HL.JP.102	175	30/35	18	30-45	4	11737
TTB.HL.JP.103	150	30/35	18	30-45	6	16147
TTB.HL.JP.104	175	30/35	18	30-45	6	16894

ORDER NO.	D	BORE	BOARD THICK	Z	PRICE
TTB.HL.JP.105	125	30/35	18	4	9766
TTB.HL.JP.106	125	30/35	25	4	9766



**Planing Cutter Head Four Wings – TTR.PC.23**



**Application**

These cutter head have been designed for planing, moulding and finishing.

**Materials**

MDF, Particle Board and Wood Composites.



**Machines**

Spindle Moulder Machine.

ORDER NO.	D	BORE	THICK	Z	SPURS	PRICE
TTR.PC.23.103051	100	30	51	4	4+4	12250
TTR.PC.23.123051	125	30	51	4	4+4	13132
TTR.PC.23.103551	100	35	51	4	4+4	12250
TTR.PC.23.123551	125	35	51	4	4+4	13132

**SPARES**

SPARES	KNIVES	WEDGE	SCREW	SPURS	SCREW
SIZE	50X12X1.5	49X10X8	M6X16G	14X14X2	M5X6C
PRICE	334	568	91	172	91



## Planning Cutter Head Two Wings – TTR.PC.24



### Application

These cutters head have been designed for planning, moulding and finishing.

### Materials

MDF, Particle Board and Wood Composites.



### Machines

Spindle Moulder Machine

ORDER NO.	D	BORE	THICK	Z	SPURS	PRICE
TTR.PC.24.103051	100	30	51	2	2+2	8443
TTR.PC.24.103551	100	35	51	2	2+2	10324
TTR.PC.24.123051	125	30	51	2	2+2	9010
TTR.PC.24.123551	125	35	51	2	2+2	10882

### SPARES

SPARES	KNIVES	WEDGE	SCREW	SPURS	SCREW
SIZE	50X12X1.5	49X10X8	M6X16G	14X14X2	M5X6C
PRICE	334	568	91	172	91



**Planing Cutter Head Four Wings – TTR.SP.25**

**Application**  
 These cutters head have been designed for planing, moulding and finishing.



**Materials**

MDF, Particle Board and Wood Composites.



**Machines**  
 Spindle Moulder Machine

**SPARES**

ORDER NO.	KNIVES	WEDGE	SCREW
TTR.SP.25.7560	60X12X1.5	59X10X8	M6X16G
PRICE	505	568	91
TTR.SP.25.1030	30X12X1.5	29X10X8	M6X16G
PRICE	262	568	91
TTR.SP.25.1050	50X12X1.5	49X10X8	M6X16G
PRICE	334	568	91
TTR.SP.25.1250	50X12X1.5	49X10X8	M6X16G
PRICE	334	568	91

ORDER NO.	D	BORE	LENGTH	Z	PRICE
TTR.SP.25.7560	75	30	60	4	13510
TTR.SP.25.1030	100	30/40	30	4	6562
TTR.SP.25.1050	100	30/40	50	4	9010
TTR.SP.25.1250	125	30/40	50	4	9766



## Straight Edge Planning Cutter Head – TTR.SE.29



### Application

These cutters head have been designed for planing, moulding and finishing.

### Materials

MDF, Particle Board and Wood Composites.



### Machines

Four Side & Six Side Spindle Machines.



ORDER NO.	D	BORE	LENGTH	Z	PRICE
TTR.SE.29.100	125	40	100	4	16894
TTR.SE.29.130	125	40	130	4	21961
TTR.SE.29.150	125	40	150	4	25336
TTR.SE.29.180	125	40	180	4	30403
TTR.SE.29.200	125	40	200	4	33787
TTR.SE.29.230	125	40	230	4	38854
TTR.SE.29.250	125	40	250	4	42238
TTR.SE.29.300	125	40	300	4	50671
TTR.SE.29.330	125	40	330	4	54055

### SPARES

KNIVES	PRICE	WEDGE	PRICE	SCREW	PRICE
100X30X3	820	21X12X100	757	M10X25G	91
130X30X3	1126	21X12X130	937	M10X25G	91
150X30X3	1234	21X12X150	1126	M10X25G	91
180X30X3	1504	21X12X180	1225	M10X25G	91
200X30X3	1504	21X12X200	1315	M10X25G	91
230X30X3	1522	21X12X230	1351	M10X25G	91
250X30X3	1693	21X12X250	1504	M10X25G	91
300X30X3	2026	21X12X300	1693	M10X25G	91
330X30X3	2197	21X12X330	1954	M10X25G	91



**Spiral Planning Cutter Head with TCT Replaceable Knives – TTR.HC.26**



**Application**

These cutters head have been designed for trimming & planing.

**Materials**

MDF, Particle Board and Wood Composites.



**Machines**

Spindle Moulder Machine.

ORDER NO.	D	BORE	THICK	Z	KNIVES QTY	PRICE
TTR.HC.26.8050	80	30/35	50	6	12	11260
TTR.HC.26.8060	80	30/35	60	6	15	14077
TTR.HC.26.8075	80	30/35	75	6	18	16894
TTR.HC.26.8010	80	30/35	100	6	24	22528
TTR.HC.26.1050	100	30/35	50	6	12	11260
TTR.HC.26.1075	100	30/35	75	6	18	16894
TTR.HC.26.1010	100	30/35	100	6	24	22528
TTR.HC.26.1012	100	30/35	120	6	30	28153
TTR.HC.26.1015	100	30/35	150	6	36	33787

**SPARES**

SPARES	KNIVES	TORX SCREW	TORX KEY
SIZE	14X14X2.0	M6X15	T20 X 120
PRICE	172	91	280



## Spiral Planning Cutter Head with TCT Replaceable Knives – TTR.HC.27

### Application

These cutters head have been designed for trimming & planning.



### Materials

MDF, Particle Board and Wood Composites.



### Machines

Spindle Moulder Machine.

ORDER NO.	D	BORE	LENGTH	Z	KNIVES QTY	PRICE
TTR.HC.27.050	125	40	50	6	12	11260
TTR.HC.27.075	125	40	75	6	18	16300
TTR.HC.27.100	125	40	100	6	24	22600
TTR.HC.27.130	125	40	130	6	30	28200
TTR.HC.27.150	125	40	150	6	36	33400
TTR.HC.27.180	125	40	180	6	42	39700
TTR.HC.27.200	125	40	200	6	48	45100
TTR.HC.27.230	125	40	230	6	54	49600
TTR.HC.27.255	125	40	255	6	60	55000
TTR.HC.27.305	125	40	305	6	72	67600

### SPARES

SPARES	KNIVES	TORX SCREW	TORX KEY
SIZE	14X14X2.0	M6X15	T20 X 120
PRICE	172	91	280



## Spiral Planning Cutter Head with TCT Replaceable Knives – TTR.HC.28

### Application

The high-performance spiral cutter head is enhancing the woodworking industry. A one of a kind of custom designed for your surface & thickness planner and double-sided moulder. It will cut noise, reduce dust & chips, cut labour and material cost for your business.

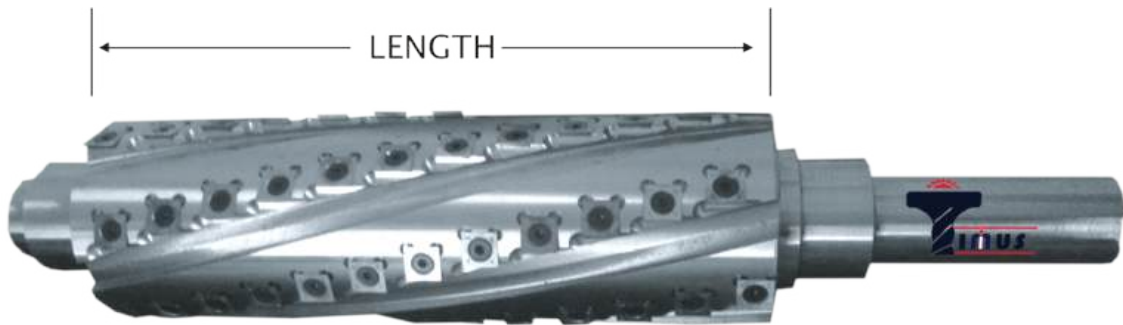

### Materials

MDF, Particle Board and Wood Composites.



### Machines

Surface & Thickness Planner and Double-Sided Moulder.

### Spiral Cutter Head

Aluminium Body Also available in steel body.

ORDER NO.	D	LENGTH	Z	KNIFE SIZE	KNIVES QTY	PRICE
TTR.HCA.28.230	100	230(9")	6	14X14X2	54	45640
TTR.HCA.28.255	100	255(10")	6	14X14X2	60	50500
TTR.HCA.28.305	100	305(12")	6	14X14X2	72	60400
TTR.HCA.28.330	100	330(13")	6	14X14X2	78	65800
TTR.HCA.28.380	100	380(15")	6	14X14X2	90	76060
TTR.HCA.28.457	100	457(18")	6	14X14X2	108	91000
TTR.HCA.28.508	100	508(20")	6	14X14X2	120	99910
TTR.HCA.28.610	100	610(24")	6	14X14X2	144	120700

### SPARES

SPARES	KNIVES	TORX SCREW	TORX KEY
SIZE	14X14X2.0	M6X15	T20 X 120
PRICE	172	91	280



## TCT Replaceable Edge Round Trimming Cutter – TTR.TC.101



### Application

For smoothing and profiling of edges.

### Materials

All types of edge banding materials PVC, PP, ABS, Melamine, Veneer & Solid Wood.

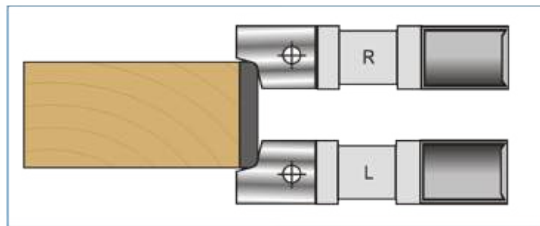

### SPARES

ORDER NO.	KNIVES	WEDGE	SCREW
TTR.WG.01.100	15X15X2	15X12X7	M6X15G
PRICE	1270	460	91
TTR.WG.01.101	15X15X2	15X12X7	M6X15G
PRICE	1270	460	91
TTR.WG.01.102	15X15X2	15X12X7	M6X15G
PRICE	1270	460	91
TTR.WG.01.103	15X15X2	15X12X7	M6X15G
PRICE	1270	460	91
TTR.WG.01.104	15X15X2	15X12X7	M6X15G
PRICE	1270	460	91
TTR.WG.01.105	15X15X2	15X12X7	M6X15G
PRICE	1270	460	91

### Machines

Edge Bander Machines (Through Feed Machines)



ORDER NO.: RH	ORDER NO.: LH	D	RADIUS	BORE	Z	PRICE
TTR.TCR.101.1.0	<b>TTR.TCL.101.1.0</b>	75	1.0	16	4	8443
TTR.TCR.101.1.3	<b>TTR.TCL.101.1.3</b>	75	1.3	16	4	8443
TTR.TCR.101.1.5	<b>TTR.TCL.101.1.5</b>	75	1.5	16	4	8443
TTR.TCR.101.2.0	<b>TTR.TCL.101.2.0</b>	75	2.0	16	4	8443
TTR.TCR.101.2.5	<b>TTR.TCL.101.2.5</b>	75	2.5	16	4	8443
TTR.TCR.101.3.0	<b>TTR.TCL.101.3.0</b>	75	3.0	16	4	8443



## TCT Replaceable Edge Round Trimming Cutter – TTR.TC.102

### Application

For smoothing and profiling of edges.



### Materials

All types of edge banding materials PVC, PP, ABS, Melamine, Veneer & Solid Wood.

### SPARES

ORDER NO.	KNIVES	WEDGE	SCREW
TTR.WG.02.100	16X13X2	13X11X8	M6X15G
PRICE	1270	550	91
TTR.WG.02.101	16X13X2	13X11X8	M6X15G
PRICE	1270	550	91
TTR.WG.02.102	16X13X2	13X11X8	M6X15G
PRICE	1270	550	91
TTR.WG.02.103	16X13X2	13X11X8	M6X15G
PRICE	1270	550	91
TTR.WG.02.104	16X13X2	13X11X8	M6X15G
PRICE	1270	550	91
TTR.WG.02.105	16X13X2	13X11X8	M6X15G
PRICE	1270	550	91

### Machines

Edge Bander Machines (Through Feed Machines).



ORDER NO.: RH	ORDER NO.: LH	D	RADIUS	BORE	THICK	Z	PRICE
TTR.TCR.102.1.0	TTR.TCL.102.1.0	69	1.0	16	13	4	9991
TTR.TCR.102.1.3	TTR.TCL.102.1.3	69	1.3	16	13	4	9991
TTR.TCR.102.1.5	TTR.TCL.102.1.5	69	1.5	16	13	4	9991
TTR.TCR.102.2.0	TTR.TCL.102.2.0	69	2.0	16	13	4	9991
TTR.TCR.102.2.5	TTR.TCL.102.2.5	69	2.5	16	13	4	9991
TTR.TCR.102.3.0	TTR.TCL.102.3.0	69	3.0	16	13	4	9991



## TCT Brazed Edge Round Trimming Cutter – TTB.TC.103

### Application

For smoothing and profiling of edges.



### Materials

All types of edge banding materials PVC, PP, ABS, Melamine, Vencer & Solid Wood.

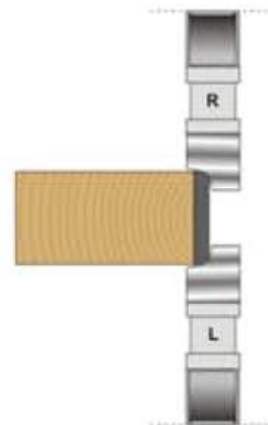

### Machines

Edge Bander Machines (Through Feed Machines).



ORDER NO.: RH	ORDER NO.: LH	D	RADIUS	BORE	THICK	Z	PRICE
TTB.TCR.103.1.0	TTB.TCL.103.1.0	48	1.0	16	9	6	5500
TTB.TCR.103.1.3	TTB.TCL.103.1.3	48	1.3	16	9	6	5500
TTB.TCR.103.1.5	TTB.TCL.103.1.5	48	1.5	16	9	6	5500
TTB.TCR.103.2.0	TTB.TCL.103.2.0	48	2.0	16	9	6	5500
TTB.TCR.103.2.5	TTB.TCL.103.2.5	48	2.5	16	9	6	5500
TTB.TCR.103.3.0	TTB.TCL.103.3.0	48	3.0	16	9	6	5500

\*Also available in PCD.



**TCT Brazed Edge Round Trimming Cutter – TTB.TC.104**

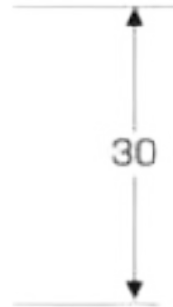

**Application**

For smoothing and profiling of edges.

**Materials**

All types of edge banding materials PVC, PP, ABS, Melamine, Veneer & Solid Wood.

**Machines**

Edge Bander Machines (Through Feed Machines).

ORDER NO.: RH	ORDER NO.: LH	D	RADIUS	BORE	THICK	Z	PRICE
TTB.TCR.104.1.0	TTB.TCL.104.1.0	68	1.0	16	12	6	6400
TTB.TCR.104.1.3	TTB.TCL.104.1.3	68	1.3	16	12	6	6400
TTB.TCR.104.1.5	TTB.TCL.104.1.5	68	1.5	16	12	6	6400
TTB.TCR.104.2.0	TTB.TCL.104.2.0	68	2.0	16	12	6	6400
TTB.TCR.104.2.5	TTB.TCL.104.2.5	68	2.5	16	12	6	6400
TTB.TCR.104.3.0	TTB.TCL.104.3.0	68	3.0	16	12	6	6400

\*Also available in PCD.



## TCT Brazed Edge Round Trimming Cutter – TTB.TC.105

### Application

For smoothing and profiling of edges.



### Materials

All types of edge banding materials PVC, PP, ABS, Melamine, Veneer & Solid Wood.

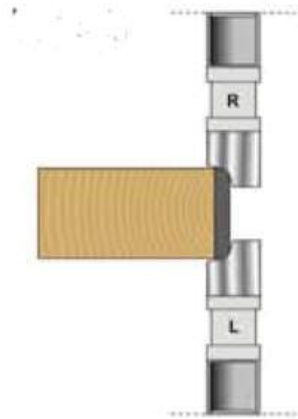

### Machines

Edge Bander Machines (Through Feed Machines).

ORDER NO.: RH	ORDER NO.: LH	D	RADIUS	BORE	THICK	Z	PRICE
TTB.TCR.105.1.0	TTB.TCL.105.1.0	48	1.0	16	9	6	5230
TTB.TCR.105.1.3	TTB.TCL.105.1.3	48	1.3	16	9	6	5230
TTB.TCR.105.1.5	TTB.TCL.105.1.5	48	1.5	16	9	6	5230
TTB.TCR.105.2.0	TTB.TCL.105.2.0	48	2.0	16	9	6	5230
TTB.TCR.105.2.5	TTB.TCL.105.2.5	48	2.5	16	9	6	5230
TTB.TCR.105.3.0	TTB.TCL.105.3.0	48	3.0	16	9	6	5230

\*Also available in PCD.



**TCT Brazed Edge Round Trimming Cutter – TTB.TC.106**



**Application**

For smoothing and profiling of edges.

**Materials**

All types of edge banding materials PVC, PP, ABS, Melamine, Veneer & Solid Wood.

**Machines**

Edge Bander Machines (Through Feed Machines).



ORDER NO.: RH	ORDER NO.: LH	D	RADIUS	BORE	THICK	Z	PRICE
TTB.TCR.106.1.0	<b>TTB.TCL.106.1.0</b>	68	1.0	16	12	6	3700
TTB.TCR.106.1.3	<b>TTB.TCL.106.1.3</b>	68	1.3	16	12	6	3700
TTB.TCR.106.1.5	<b>TTB.TCL.106.1.5</b>	68	1.5	16	12	6	3700
TTB.TCR.106.2.0	<b>TTB.TCL.106.2.0</b>	68	2.0	16	12	6	3700
TTB.TCR.106.2.5	<b>TTB.TCL.106.2.5</b>	68	2.5	16	12	6	3700
TTB.TCR.106.3.0	<b>TTB.TCL.106.3.0</b>	68	3.0	16	12	6	3700

\*Also available in PCD.



## TCT Brazed Edge Round Trimming Cutter – TTB.TC.107

### Application

For smoothing and profiling of edges.



### Materials

All types of edge banding materials PVC, PP, ABS, Melamine, Veneer & Solid Wood.



### Machines

Edge Bander Machines (Through Feed Machines).

ORDER NO.: RH	ORDER NO.: LH	D	RADIUS	BORE	THICK	Z	PRICE
TTB.TCR.107.1.0	<b>TTB.TCL.107.1.0</b>	68	1.0	16	20	6	5230
TTB.TCR.107.1.3	<b>TTB.TCL.107.1.3</b>	68	1.3	16	20	6	5230
TTB.TCR.107.1.5	<b>TTB.TCL.107.1.5</b>	68	1.5	16	20	6	5230
TTB.TCR.107.2.0	<b>TTB.TCL.107.2.0</b>	68	2.0	16	20	6	5230
TTB.TCR.107.2.5	<b>TTB.TCL.107.2.5</b>	68	2.5	16	20	6	5230
TTB.TCR.107.3.0	<b>TTB.TCL.107.3.0</b>	68	3.0	16	20	6	5230

\*Also available in PCD.



**TCT Brazed Edge Round Trimming Cutter – TTB.TC.108**

**Application**

For smoothing and profiling of edges.



**Materials**

All types of edge banding materials PVC, PP, ABS, Melamine, Veneer & Solid Wood.



**Machines**

Edge Bander Machines (Through Feed Machines).

ORDER NO.: RH	ORDER NO.: LH	D	RADIUS	BORE	THICK	Z	PRICE
TTB.TCR.108.1.0.58	TTB.TCL.108.1.0.58	58	1.0	16	8	6	4510
TTB.TCR.108.1.3.58	TTB.TCL.108.1.3.58	58	1.3	16	8	6	4510
TTB.TCR.108.1.5.58	TTB.TCL.108.1.5.58	58	1.5	16	8	6	4510
TTB.TCR.108.2.0.58	TTB.TCL.108.2.0.58	58	2.0	16	8	6	4510
TTB.TCR.108.1.0.68	TTB.TCL.108.1.0.68	68	1.0	16	8	6	4510
TTB.TCR.108.1.3.68	TTB.TCL.108.1.3.68	68	1.3	16	8	6	4510
TTB.TCR.108.1.5.68	TTB.TCL.108.1.5.68	68	1.5	16	8	6	4510
TTB.TCR.108.2.0.68	TTB.TCL.108.2.0.68	68	2.0	16	8	6	4510
TTB.TCR.108.1.0.78	TTB.TCL.108.1.0.78	78	1.0	16	10	6	4510
TTB.TCR.108.1.3.78	TTB.TCL.108.1.3.78	78	1.3	16	10	6	4510
TTB.TCR.108.1.5.78	TTB.TCL.108.1.5.78	78	1.5	16	10	6	4510
TTB.TCR.108.2.0.78	TTB.TCL.108.2.0.78	78	2.0	16	10	6	4510

\*Also available in PCD.



## TCT Brazed Edge Round Trimming Cutter – TTB.TC.109



### Application

For smoothing and profiling of edges.



### Materials

All types of edge banding materials PVC, PP, ABS, Melamine, Veneer & Solid Wood.



### Machines

Edge Bander Machines (Through Feed Machines).

ORDER NO.: RH	ORDER NO.: LH	D	RADIUS	BORE	THICK	Z	PRICE
TTB.TCR.109.1.0	<b>TTB.TCL.109.1.0</b>	68	1.0	16	16	6	3700
TTB.TCR.109.1.3	<b>TTB.TCL.109.1.3</b>	68	1.3	16	16	6	3700
TTB.TCR.109.1.5	<b>TTB.TCL.109.1.5</b>	68	1.5	16	16	6	3700
TTB.TCR.109.2.0	<b>TTB.TCL.109.2.0</b>	68	2.0	16	16	6	3700
TTB.TCR.109.2.5	<b>TTB.TCL.109.2.5</b>	68	2.5	16	16	6	3700
TTB.TCR.109.3.0	<b>TTB.TCL.109.3.0</b>	68	3.0	16	16	6	3700

\*Also available in PCD.



**TCT End Cutting Saw Blade for Edge Bander Machines – TT.EC**



**Application**  
For edge banding end cutting both sides.

**Materials**  
All types of edge banding materials  
PVC, PP, ABS.



**Machines**  
Edge Bander Machines (Through Feed Machines).

ORDER NO.: RH	ORDER NO.: LH	D	THICK	BORE	Z	PRICE	MACHINE
TT.EC.1003230R	<b>TT.EC.1003230L</b>	100	2.8	32	30	3340	HOMAG
TT.EC.1002030R	<b>TT.EC.1002030L</b>	100	3.2	20	30	3340	FELDER/UMABOY
TT.EC.1002230R	<b>TT.EC.1002230L</b>	100	3.2	22	30	3340	JAI
TT.EC.1042230R	<b>TT.EC.1042230L</b>	104	3.2	22	30	3340	KDT/JAI
TT.EC.1202230R	<b>TT.EC.1202230L</b>	120	3.2	22	30	3340	JAI
TT.EC.1403036R	<b>TT.EC.1403036L</b>	140	3.5	30	36	4510	BIESSE

\*Also available in PCD.



## Cutter Head Set for Tenoning – TTR.TN.37



### Application

Designed for Tenoning in all materials.

### Materials

Hard Wood and Wooden Composite.



### Machines

Tenoning Machine.

ORDER NO.: RH	D	BORE	WOOD THICK	Z	PRICE
TTR.TN.37.101	150	25.4	25	8+4	55000

ORDER NO.	GRADE	W	H	T	ANGLE	Z	PRICE
106822-TT	T04MG-CR	7.5	12	1.5	35°	2	163
106823-TT	T04MG-CR	9.6	12	1.5	35°	2	181
106835-TT	T04MG-CR	12	12	1.5	35°	2	199
106824-TT	T04MG-CR	15	12	1.5	35°	2	244
104796-TT	T04MG-CR	20	12	1.5	35°	2	190

ORDER NO.	GRADE	W	H	T	ANGLE	Z	PRICE
013295-TT	T08MF	14	14	1.2	30°	4	262
014028-TT	T10MG	14	14	2.0	30°	4	163
104118-TT	T10MG	15	15	2.5	R-0.5/30°	4	199
013315-TT	T10MG	15	15	2.5	30°	4	190
109384-TT	T10MG	15	15	2.5	R-0.5/37°	4	199
104062-TT	T10MG	15	15	2.5	37°	4	190
101540-TT	T10MG	15	15	2.5	R-150/30°	4	280

### SPARES

ORDER NO.: RH	PRICE	SCREW	PRICE
14X14X2	172	M5X10C	91

\*Also available in PCD.



**TCT Replaceable Standard Knives**

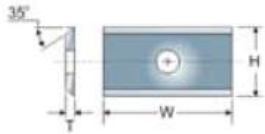

ORDER NO.	GRADE	W	H	T	ANGLE	Z	PRICE
104795-TT	T04MG-CR	30	12	1.5	35°	2	208
054259-TT	T04MG-CR	30	12	2.5	35°	2	352
106828-TT	T04MG-CR	40	12	1.5	35°	2	253
106829-TT	T04MG-CR	50	12	1.5	35°	2	271
106830-TT	T04MG-CR	60	12	1.5	35°	2	370

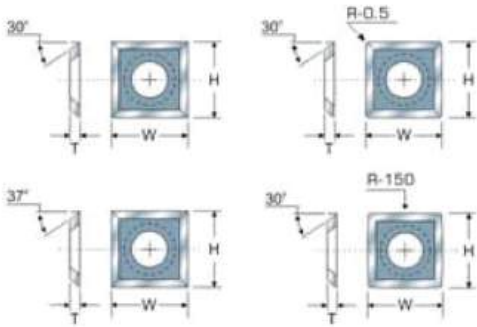

ORDER NO.	ORDER NO.	W	H	R	PRICE
TT.TK.101.10.RH	TT.TK.101.10.LH	12	14.5	1	1450
TT.TK.101.13.RH	TT.TK.101.13.LH	12	14.5	1.3	1450
TT.TK.101.15.RH	TT.TK.101.15.LH	12	14.5	1.5	1450
TT.TK.101.20.RH	TT.TK.101.20.LH	12	14.5	2	1450
TT.TK.101.25.RH	TT.TK.101.25.LH	12	14.5	2.5	1450
TT.TK.101.30.RH	TT.TK.101.30.LH	12	14.5	3	1450

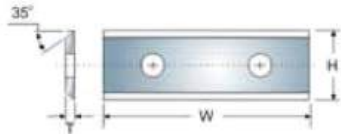

ORDER NO.	GRADE	W	H	T	ANGLE	Z	PRICE
013504-TT	T04F-CR	29.5	9	1.5	35°	4	298
013507-TT	T04F-CR	29.5	12	1.5	35°	4	253
013517-TT	T04F-CR	49.5	9	1.5	35°	4	370
013520-TT	T04F-CR	49.5	12	1.5	35°	4	352
017047-TT	T04F-CR	48.0	12	1.5	35°	4	460

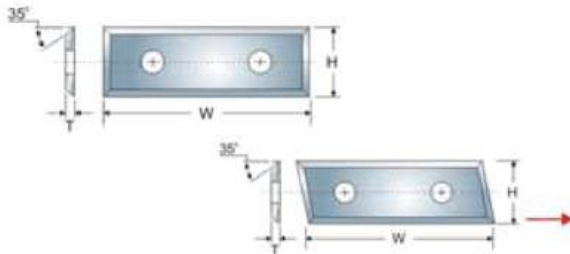

ORDER NO.	GRADE	W	H	T	ANGLE	Z	PRICE
105980-TT	T04MG-CR	50	12	1.7	35°	4	370



ORDER NO.	GRADE	W	H	T	ANGLE	Z	PRICE
013403-TT	T04F-CR	20	4.1	1.1	35°	4	280
013394-TT	T04F-CR	20	5.5	1.1	35°	4	280
013402-TT	T04F-CR	25	5.5	1.1	35°	4	298
013397-TT	T04F-CR	30	5.5	1.1	35°	4	271
013399-TT	T04F-CR	40	5.5	1.1	35°	4	370
013401-TT	T04F-CR	50	5.5	1.1	35°	4	325



ORDER NO.	GRADE	W	H	T	ANGLE	Z	PRICE
013293-TT	T08MF	18	18	1.95	35°	4	460
013291-TT	T08MF	18	18	1.95	35°	4	550
013305-TT	T08MF	18	18	1.95	35°	4	730

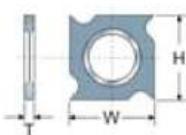

## TCT Replaceable Trimming Knives for Edge Rounding

**TT.TK.101**

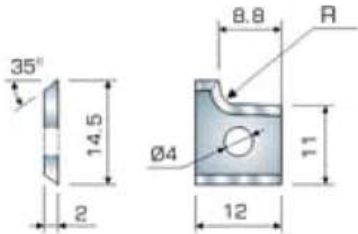

ORDER NO.	ORDER NO.	W	H	R	PRICE
TT.TK.101.30.RH	TT.TK.101.30.LH	12	14.5	3	1450

**TT.TK.102**

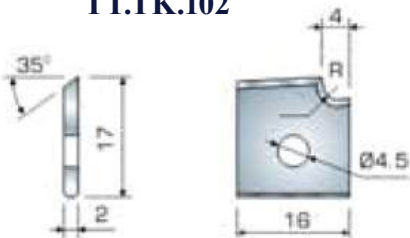

ORDER NO.	ORDER NO.	W	H	R	PRICE
TT.TK.102.10.RH	TT.TK.102.10.LH	16	17	1	1630
TT.TK.102.13.RH	TT.TK.102.13.LH	16	17	1.3	1630
TT.TK.102.15.RH	TT.TK.102.15.LH	16	17	1.5	1630
TT.TK.102.20.RH	TT.TK.102.20.LH	16	17	2	1630
TT.TK.102.25.RH	TT.TK.102.25.LH	16	17	2.5	1630
TT.TK.102.30.RH	TT.TK.102.30.LH	16	17	3	1630

**TT.TK.103**

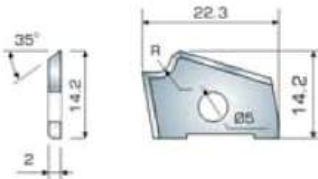

ORDER NO.	ORDER NO.	W	H	R	PRICE
TT.TK.103.10.RH	TT.TK.103.10.LH	22.3	14.2	1	2620
TT.TK.103.13.RH	TT.TK.103.13.LH	22.3	14.2	1.3	2620
TT.TK.103.15.RH	TT.TK.103.15.LH	22.3	14.2	1.5	2620
TT.TK.103.20.RH	TT.TK.103.20.LH	22.3	14.2	2	2620
TT.TK.103.25.RH	TT.TK.103.25.LH	22.3	14.2	2.5	2620
TT.TK.103.30.RH	TT.TK.103.30.LH	22.3	14.2	3	2620

**TT.TK.109**

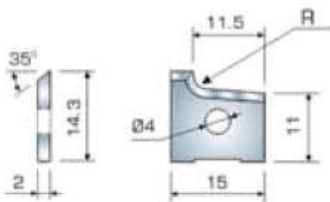

ORDER NO.	ORDER NO.	W	H	R	PRICE
TT.TK.109.10.RH	TT.TK.109.10.LH	15	14.3	1	1450
TT.TK.109.13.RH	TT.TK.109.13.LH	15	14.3	1.3	1450
TT.TK.109.15.RH	TT.TK.109.15.LH	15	14.3	1.5	1450
TT.TK.109.20.RH	TT.TK.109.20.LH	15	14.3	2	1450
TT.TK.109.25.RH	TT.TK.109.25.LH	15	14.3	2.5	1450
TT.TK.109.30.RH	TT.TK.109.30.LH	15	14.3	3	1450

**TT.TK.110**

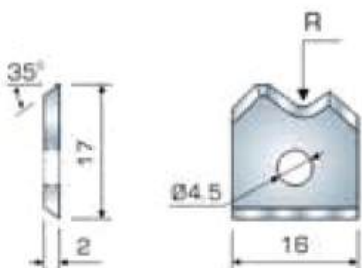

ORDER NO.	ORDER NO.	W	H	R	PRICE
TT.TK.110.10.RH	TT.TK.110.10.LH	16	17	1	1450
TT.TK.110.13.RH	TT.TK.110.13.LH	16	17	1.3	1450
TT.TK.110.15.RH	TT.TK.110.15.LH	16	17	1.5	1450
TT.TK.110.20.RH	TT.TK.110.20.LH	16	17	2	1450
TT.TK.110.25.RH	TT.TK.110.25.LH	16	17	2.5	1450
TT.TK.110.30.RH	TT.TK.110.30.LH	16	17	3	1450



**TCT Replaceable Trimming Knives for Edge Rounding**

**TT.TK.111**

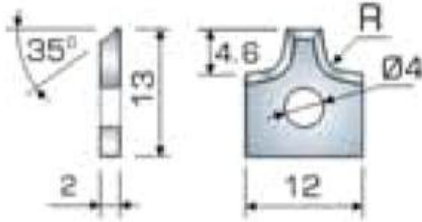

ORDER NO.	W	H	R	PRICE
TT.TK.111.10	12	13	1	1630
TT.TK.111.13	12	13	1.3	1630
TT.TK.111.15	12	13	1.5	1630
TT.TK.111.20	12	13	2	1630
TT.TK.111.25	12	13	2.5	1630
TT.TK.111.30	12	13	3	1630

**TT.TK.112**

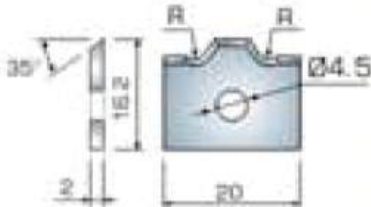

ORDER NO.	W	H	R	PRICE
TT.TK.112.10	20	16.2	1	1630
TT.TK.112.13	20	16.2	1.3	1630
TT.TK.112.15	20	16.2	1.5	1630
TT.TK.112.20	20	16.2	2	1630
TT.TK.112.25	20	16.2	2.5	1630
TT.TK.112.30	20	16.2	3	1630

**TT.TK.113**

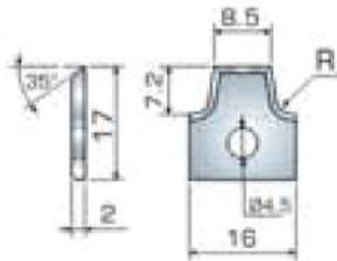

ORDER NO.	W	H	R	PRICE
TT.TK.113.10	16	16.5	1	1630
TT.TK.113.13	16	16.5	1.3	1630
TT.TK.113.15	16	16.5	1.5	1630
TT.TK.113.20	16	16.5	2	1630
TT.TK.113.25	16	16.5	2.5	1630
TT.TK.113.30	16	16.5	3	1630

**TT.TK.114**

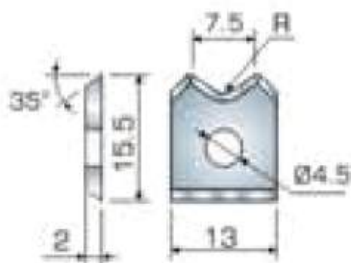

ORDER NO.	W	H	R	PRICE
TT.TK.114.10	13	15.5	1	1450
TT.TK.114.13	13	15.5	1.3	1450
TT.TK.114.15	13	15.5	1.5	1450
TT.TK.114.20	13	15.5	2	1450
TT.TK.114.25	13	15.5	2.5	1450
TT.TK.114.30	13	15.5	3	1450



## TCT Replaceable Scrapper Unit Knives

### TT.TK.115

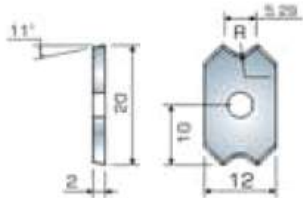

ORDER NO.	W	H	R	PRICE
TT.TK.115.10	12	20	1	550
TT.TK.115.13	12	20	1.3	550
TT.TK.115.15	12	20	1.5	550
TT.TK.115.20	12	20	2	550
TT.TK.115.25	12	20	2.5	550
TT.TK.115.30	12	20	3	550

### TT.TK.116

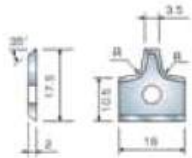

ORDER NO.	W	H	R	PRICE
TT.TK.116.10	16	17.5	1	1630
TT.TK.116.13	16	17.5	1.3	1630
TT.TK.116.15	16	17.5	1.5	1630
TT.TK.116.20	16	17.5	2	1630
TT.TK.116.25	16	17.5	2.5	1630
TT.TK.116.30	16	17.5	3	1630

### TT.TK.117

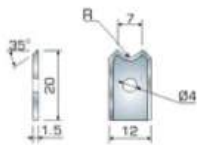

ORDER NO.	W	H	R	PRICE
TT.TK.117.10	12	20	1	1090
TT.TK.117.13	12	20	1.3	1090
TT.TK.117.15	12	20	1.5	1090
TT.TK.117.20	12	20	2	1090
TT.TK.117.25	12	20	2.5	1090
TT.TK.117.30	12	20	3	1090

### TT.TK.118

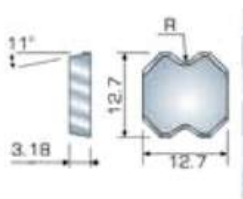

ORDER NO.	W	H	R	PRICE
TT.TK.118.10	12.7	12.7	1	1270
TT.TK.118.13	12.7	12.7	1.3	1270
TT.TK.118.15	12.7	12.7	1.5	1270
TT.TK.118.20	12.7	12.7	2	1270
TT.TK.118.25	12.7	12.7	2.5	1270
TT.TK.118.30	12.7	12.7	3	1270

### TT.TK.119

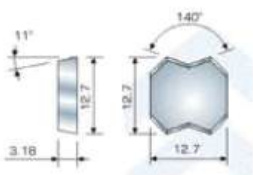

### TT.TK.120

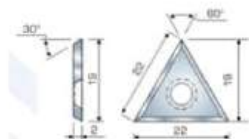

### TT.TK.121

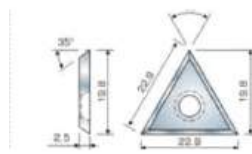

### TT.TK.122



MADE IN GERMANY

**Mortise Chisel & Bit Sets – TT.CB**



**Application**

It is tough to beat the old faithful mortise and tenon joint for strength and accuracy. Even with all the other joining option in the world of woodworking. It is not the easiest joint to make, but for sure it helps have the best quality tools in your workshop, that's why we have added a new selection of chisel bit sets in all the popular sizes 1/4" to 1" diameter.

**Materials**

Solid wood.



**Machines**

Standard Drill Press Mortising Attachment of Mortising Machines.

ORDER NO.	C.D.	WITH ACCESSORY	PRICE
TT.HCS.01.4	1/4"	Guide Bar & Gear	6400
TT.HCS.5.16	5/16"	Guide Bar & Gear	6400
TT.HCS.03.8	3/8"	Guide Bar & Gear	5230
TT.HCS.7.16	7/16"	Guide Bar & Gear	5230
TT.HCS.01.2	1/2"	Guide Bar & Gear	5230
TT.HCS.05.8	5/8"	Guide Bar & Gear	6850
TT.HCS.03.4	3/4"	Guide Bar & Gear	8740
TT.HCS.01.0	1"	Guide Bar & Gear	9910
TT.HCS.1.14	1 1/4"	Guide Bar & Gear	11620
TT.HCS.I.01.2	1/2"	Guide Bar & Gear	19000

ORDER NO.	C.D.	C.L.	OAL	S.D.	PRICE
TT.CB.1.4.40	1/4"	40	210	3/4"	1180
TT.CB.5.16.60	5/16"	60	210	3/4"	1180
TT.CB.3.8.60	3/8"	60	210	3/4"	1180
TT.CB.3.8.75	3/8"	75	210	3/4"	1270
TT.CB.7.16.75	7/16"	75	210	3/4"	1270
TT.CB.1.2.75	1/2"	75	210	3/4"	1270
TT.CB.5.8.90	5/8"	90	210	3/4"	2080
TT.CB.3.4.90	3/4"	90	210	3/4"	2800
TT.CB.7.8.90	7/8"	90	210	3/4"	3700
TT.CB.01.90	1"	90	210	3/4"	3700



**H.C.S. and TCT Chain Set for Chain Mortising Machine**



**H.C.S. Chain Set**  
**T.C.T. Chain Set (Carbide Tipped)**



ORDER NO.	C.D.	WITH ACCESSORY	PRICE
TT.TCT.03.8	3/8"	Guide Bar & Gear	17830
TT.TCT.7.16	7/16"	Guide Bar & Gear	17830
TT.TCT.01.2	1/2"	Guide Bar & Gear	17830
TT.TCT.05.8	5/8"	Guide Bar & Gear	21700
TT.TCT.03.4	3/4"	Guide Bar & Gear	24400
TT.TCT.01.0	1"	Guide Bar & Gear	33400

**TCT Brazed Finger Joint Cutter – TTB.FJ.25**



ORDER NO.	D	THICK	BORE	CL	Z	PRICE
TTB.FJ.25.1093	125	5	31.75	15	4	1180
TTB.FJ.25.1093-A	125	5	40	15	4	1180
TTB.FJ.25.1094	125	7	31.75	22	4	1180
TTB.FJ.25.1094-AA	125	7	40	22	4	1180
TTB.FJ.25.1094-A	125	10	31.75	25	4	1630



**TCT Brazed Solder Cutter – TTB.SLD.25**

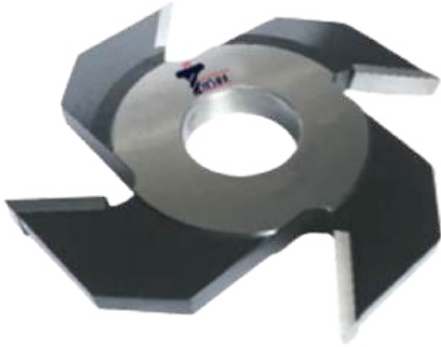

ORDER NO.	D	THICK	BORE	CL	Z	PRICE
TTB.SLD.25.101	125	5/10	31.75	15	4	2800
TTB.SLD.25.101-A	125	5/10	40	15	4	2800
TTB.SLD.25.102	125	7/12	31.75	22	4	2800
TTB.SLD.25.102-A	125	7/12	40	22	4	2800
TTB.SLD.25.103	125	10/14	31.75	25	4	3700

**TCT Brazed Facing Cutter – TTB.FC.25**

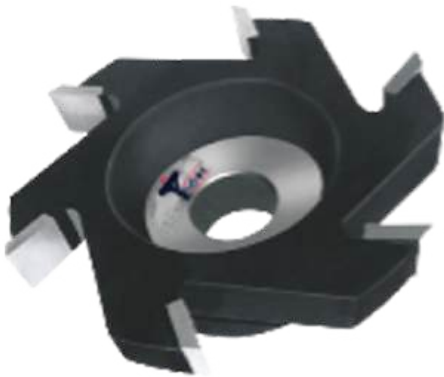

ORDER NO.	D	THICK	BORE	CL	Z	PRICE
TTB.FC.25.101	5"	18/38	25.4	38	6	4600
TTB.FC.25.102	6½"	18/38	25.4	38	6	5500
TTB.FC.25.103	7"	18/38	25.4	38	6	6130

**TCT Brazed Finger Joint Cutter – TTB.FJ.26**



ORDER NO.	D	THICK	BORE	CL	Z	PRICE
TTB.FJ.26.1095	160	4	50	13	2	1450
TTB.FJ.26.1095-Z4	160	4	50	13	4	2170
TTB.FJ.26.1095-A	160	5	50	15	4	3700
TTB.FJ.26.1095-B	160	6	50	22	4	3700
TTB.FJ.26.1095-C	160	7	50	22	4	3700

**TCT Brazed Solder Cutter – TTB.SLD.26**



ORDER NO.	D	THICK	BORE	CL	Z	PRICE
TTB.SLD.25.104	160	4/10	50	13	2	5230
TTB.SLD.25.105	160	4/10	50	13	4	5950



## Precision Collets for CNC Router Machining Centre – Standard



**Machines**  
All CNC Router Machines

**ER20**



ORDER NO.	SD	PRICE
ER20.03	3	640
ER20.04	4	640
ER20.05	5	640
ER20.06	6	640
ER20.08	8	640
ER20.10	10	640
ER20.12	12	640
ER20.13	13	640

**ER25**



ORDER NO.	SD	PRICE
ER25.03	3	640
ER25.04	4	640
ER25.05	5	640
ER25.06	6	640
ER25.08	8	640
ER25.10	10	640
ER25.12	12	640
ER25.13	13	640
ER25.16	16	640

**ER32**



ORDER NO.	SD	PRICE
ER32.03	3	640
ER32.04	4	640
ER32.05	5	640
ER32.06	6	640
ER32.08	8	640
ER32.10	10	640
ER32.12	12	640
ER32.13	13	640
ER32.16	16	640
ER32.18	18	640

**ER40**



ORDER NO.	SD	PRICE
ER40.03	3	1270
ER40.04	4	1270
ER40.05	5	1270
ER40.06	6	1270
ER40.08	8	1270
ER40.10	10	1270
ER40.12	12	1270
ER40.13	13	1270
ER40.16	16	1270
ER40.18	18	1270
ER40.20	20	1270



## DP (PCD) Pre-Milling Cutter Head 30o with Changeable Knives



### Application

FAnti-chipping cutter heads for edge bander machine.

### Materials

Laminated Boards, Chip Board, Ply Board and Veneered Panels



### Machines

Use on all Edge Bander Machine (Through Feed)

ORDER NO.: RH	ORDER NO.: LH	D	BORE	CUTTING EIGHT	Z	MACHINE	PRICE
TTDR.TOK.HM.44.RH	TTDR.TOK.HM.44.LH	100	30	44	3+3	HOMAG	45100
TTDR.TOK.HM.65.RH	TTDR.TOK.HM.65.LH	100	30	65	3+3	HOMAG	73000
TTDR.TOK.BS.44.RH	TTDR.TOK.BS.44.LH	80	30	44	3+3	BIESSE	42400
TTDR.TOK.BS.65.RH	TTDR.TOK.BS.65.LH	80	30	65	3+3	BIESSE	64000
TTDR.TOK.WT.40.RH	TTDR.TOK.WT.40.LH	125	30	40	3+3	KDT/JAI	46000
TTDR.TOK.WT.65.RH	TTDR.TOK.WT.65.LH	125	30	65	3+3	KDT/JAI	69400
TTDR.TOK.FD.47.RH	TTDR.TOK.FD.47.LH	80	25	47	2+2	FELDER	37000
TTDR.TOK.AD.43.RH	TTDR.TOK.AD.43.RH	70	25	43	2+2	ALTENDORF	29800
TTDR.TOK.SC.51.RH	TTDR.TOK.SC.51.LH	100	30	51	3+3	SCM	65800

### SPARES

ORDER NO.	I	L	Z	PRICE
TTD.TOK.14147	14	14.70	1	3160
TTD.600.893.70	14	14.70	1	3160
TTD.600.893.71.LU	14	17	1	4330

ORDER NO.	SIZE	PRICE
TTD.CK.074	M5X12	262
TTD.CK.075	M5X12	262
TTD.CK.076	M5X12	262



## DP (PCD) Straight Router Cutter

**AXIAL ANGLE  
30-60**

**RPM MAX  
24000**

**PCD**



### Application

Used for grooving in cabinet back panel and routing.

### Materials

Softwood, hardwood, plywood, wood-based panels, plastic material and laminates.



ORDER NO.	D	S.D.	C.L.	O.A.L.	Z	PRICE
TTD.800C.0815.75	8	8	15	65	2	14500
TTD.800C.0820.75	8	8	20	65	2	16300
TTD.800C.0915.75	9	10	15	70	2	15400
TTD.800C.0920.75	9	10	20	70	2	18100
TTD.800C.1015.75	10	10	15	70	2	16300
TTD.800C.1020.75	10	10	20	70	2	19900
TTD.800C.1215.75	12	12	15	75	2	17830
TTD.800C.1221.75	12	12	21	75	2	19900
TTD.800C.1227.75	12	12	27	75	2	21700

### Machines

CNC machines.



\*Special Sizes available as per customer needs.



## TCT Hand Planner Knife



ORDER NO.	WIDTH	THICK	LENGTH	PRICE	PRICE (Premium)
TT.969-P	1" (Plain)	2	130	145	181
TT.969A-P	1 ¼" (Plain)	2	130	154	190
TT.970-P	1 ½" (Plain)	2	130	163	199
TT.971-P	1 ¾" (Plain)	2	140	172	208
TT.971-H	1 ¾" (Slot)	2	140	172	208
TT.972-P	2" (Plain)	2	140	172	208
TT.972-H	2" (Slot)	2	140	172	208
TT.973-P	2 ½" (Plain)	2	150	307	334
TT.973-H	2 ½" (Slot)	2	150	307	334
TT.974-P	35mm (Plain)	2	90	163	199
TT.975-P	42mm (Plain)	2	120	172	208

## TCT Brazed Electric Planner Knife



ORDER NO.	Length	Width	Thick	Use In	PRICE
TT.976	82	30	3	Hitachi-F20A M/C	379
TT.976-A	82	30	3	Makita 1900B M/C	379
TT.976-AA	82	30	3	Hitachi & Makita	379

## TCT Brazed Planner Blade - TTR.PB.38

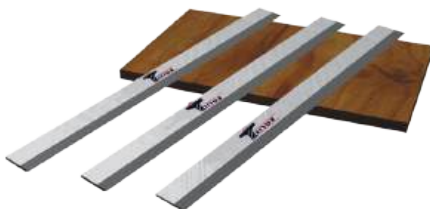

ORDER NO.	Length	Width	Thick	TCT INLAY	PRICE
TTR.PB.38.101	130	30	3	10	910
TTR.PB.38.102	150	30	3	10	955
TTR.PB.38.103	230	30	3	10	1360
TTR.PB.38.104	255	30	3	10	1450
TTR.PB.38.105	305	30	3	10	1792
TTR.PB.38.106	330	30	3	10	1954
TTR.PB.38.107	405	30	3	10	2395
TTR.PB.38.108	455	30	3	10	2692
TTR.PB.38.109	510	30	3	10	2998
TTR.PB.38.110	610	30	3	10	3592
TTR.PB.38.111	810	30	3	10	4780
TTR.PB.38.112	260	30	5	10	1693



**T20 Bits**



Price:55

**Star Bits**



Price:64

**Staples**



Price:55

**Nails**



**Screw**



Price:91

**Allen Key**



Price:370

**Router Bit Set (Economy)**



Price:2170

**Glue Applicator**

6" Glue Applicator  
Price:1180  
3" Glue Applicator  
Price:1090



Spare Roller Foams  
6" Roller  
Price:280  
3" Roller  
Price:280

## Grinding Wheel for TCT Circular Saw Resharpener



## Grinding Wheel for HSS Circular Saw Resharpener



## Our Other Ranges of Woodworking Tools



# Glimpses From Exhibitions





*Where quality is never compromised...*

AN ISO 9001 : 2015 CERTIFIED COMPANY



**Countries We Are Outsourcing From**



**Kh.NO-835 Mandi Village Dera Mandi Road Near  
Janki Max Hospital ND-110047**

☎ 9266384544, 9717358599

✉ [timustooling@hotmail.com](mailto:timustooling@hotmail.com)

[www.timustooling.com](http://www.timustooling.com)