



**SHREDO**<sup>®</sup>  
SIZE REDUCTION SOLUTIONS

Capacity : 1 - 60 TPH, Output Size : 1 - 2 Inch or Customize

**LOWEST POWER CONSUMPTION  
HEAVY DUTY INDUSTRIAL  
SHREDDING SYSTEMS**



**IDEA HOLDING LIMITED**

+91 98152 74547

[www.shredorecycling.com](http://www.shredorecycling.com)

[shredo@ideamails.com](mailto:shredo@ideamails.com)

# COMPANY PROFILE



Since 1992, **IDEA HOLDING LIMITED** is a prominent manufacturer, supplier and exporter of heavy duty Shredding Machines, Conveyors and spare parts thereof under brand name “**SHREDO**”, based in Ludhiana, an industrial hub of Punjab (India). We are having more than three decades of experience and commissioned number of systems/projects around the globe related to waste management with different industries such as, Municipal Solid Waste Processing Plants, Biomass Power Plants, Sugar Mills, Refineries, 2G Bio-Ethanol Plants, Bio-CNG, Bio-Gas, Cement Plants, Hazardous Waste Processing Plants and etc.

We are a reputed member of Confederation of Indian Industry (**CII**), Chamber of Industrial & Commercial Undertaking (**CICU**), SMERA, Federation of Indian Export Organization (**FIEO**) and have an age-old name in the industry, hence we never compromise on the quality aspects of our products. Such adherence to quality has helped us be accredited with an **ISO9001:2018 Certification** and **Patent Design**.

We are dedicated to use our professional knowledge and experience for the welfare of the global recycling industries. We have been solving critical size reduction problems by finding cost effective solutions combined with engineering excellence. For the flawless functioning and to extend service life of SHREDO products, we use high quality raw material from international and domestic vendors. We follow all the proven manufacturing and testing processes like Welding, Paint, NDT etc. to produce efficient, useful, reliable and robust products.

Our production facilities are being continuously upgraded to industrial standards, thereby making us the largest manufacturers of its kind in the industry. Spread over an area of more than 65000sqft, we are privileged to have our own in-house production facilities for the fabrication of different kinds of size reduction equipment. Further we understand the market needs and our research team, manned by highly skilled designers, engineers & technicians, always endeavours to give us an edge over our competitors in producing innovative accurate products. Our R&D facility has the capability to design and develop prototypes and to custom products to meet the specific need of our worldwide clients.

Sticking to our motto of pro-customer and customer satisfaction, we also offer service contract, after sale services, on-site services and other such services to the clients using the advanced tools and techniques. We always work together to meet our common goals and honour the rights & beliefs of our fellow, associates, customers, suppliers and community with the highest degree of dignity, equality and trust.

I take this opportunity to thank our valued customers, whose continued patronage and showed confidence in our products inspire us to extend the best of service and enable us to provide value for their money. Idea Holding Limited has climbed the ladder of success gradually by overcoming challenges, intensively delivered best performance and focus on customer satisfaction. Our key strategy is to provide best solutions to our customers rather than selling only equipment.

We are operating in the market for more than 3 decades, which gave us the deep understanding of market dynamics and client needs. We always keep our clients in the heart of our operations, hence, we continuously seek to improve our performance to deliver better services that match our client needs, the customers trust we gain is the base for our growth and sustainable success.

We are now in an ever changing market situation, so we firmly believe that “trust” is the main element in persuading clients to choose our best quality products. I would like to thank again all those who have contributed relentless hard work and effort of the past to bring up here today and will continue to grow for years to come.

## VISION

A Company, directed by its customers, driven by its employees, towards a common goal of providing exceptional products and service on a daily basis-meeting the demands of a constantly changing global market. Striving to make certain that every single transaction result in a positive experience.

## MISSION

To Provide Effective Solution Through Innovative Products, Services and Teamwork

## CERTIFICATIONS



FEDERATION OF INDIAN EXPORT ORGANISATIONS  
Set up by Ministry of Commerce, Government of India  
ISO 9001:2015 Certified



SME RATING AGENCY OF INDIA



# INDUSTRIES WE CATER



8-9

**CEMENT PLANTS (AFR)**



10

**MSW PROCESSING PLANTS**



11

**RDF SHREDDING PLANTS**



12-13

**BIOMASS POWER PLANTS**



14-15

**SUGAR INDUSTRIES**



16

**WOOD INDUSTRIES**



17

**PALM OIL INDUSTRIES**



18

**TEXTILE INDUSTRIES**



18

**PHARMACEUTICAL INDUSTRY**



19

**HAZARDOUS WASTE PLANTS**



19

**PLASTIC WASTE PLANTS**



20

**METAL SHREDDING PLANTS**



21

**E-WASTE PLANTS**



22-23

**TYRE SHREDDING PLANTS**



24-25

**PAPER SHREDDING AND  
BRIQUETTING PLANTS**

Idea Holding Limited is a professional company in which all latest machines and technology are used for smooth manufacturing. We have world class infrastructure to manufacture our complete product range from Industrial Shredders to Conveyors to spare parts thereof. The company is well equipped with best facilities to undertake complete product development process right from designing to manufacturing. With top class CNC, VMC, CNC Plasma, Boring Machines and other conventional machines, we ensure good quality, standards and finishing of our each product. We don't mind to add new machines as per customer's regular requirements.



## QUALITY POLICY

Commitment to Quality . . . SHREDO Q-101 Quality Program is shaping our future through teamwork, employee involvement, and continuous improvement. To us, quality is a satisfied customer achieved by quality people producing quality products.”

We will lead the way to a better tomorrow by Partnering with our entire “Venture holders”, to supply products and services of Superior Value.

“Venture holders” are our worldwide customers, our employees, our families, our relatives, Our Financer, our shareholders, our suppliers, our communities, our country and our well-wishers.

We will "Partner" to learn the real needs, wants, and desires of our Customers, and balance those fairly with those of our other “Venture holders”, for the long term mutual benefit of all.

SHREDO -101 Means:  
100% Quality  
from 100% of Our People  
100% of the Time  
for our next 101 Years



Idea Holding Limited is growing, updating and expanding its operations throughout the world with a keen eye on relevant skills, technology and products of a dynamic global market. Presently, with a strong foothold in India, Malaysia, Bangladesh, Sri Lanka, Thailand, Indonesia, Mauritius, Nigeria, Russia, USA & Canada, we have attained an established reputation through bulk exports of Shredding Machines and Spare Parts thereof to our valuable clients in these countries. We are also making strenuous efforts regularly to explore the potential of our business in the new markets.

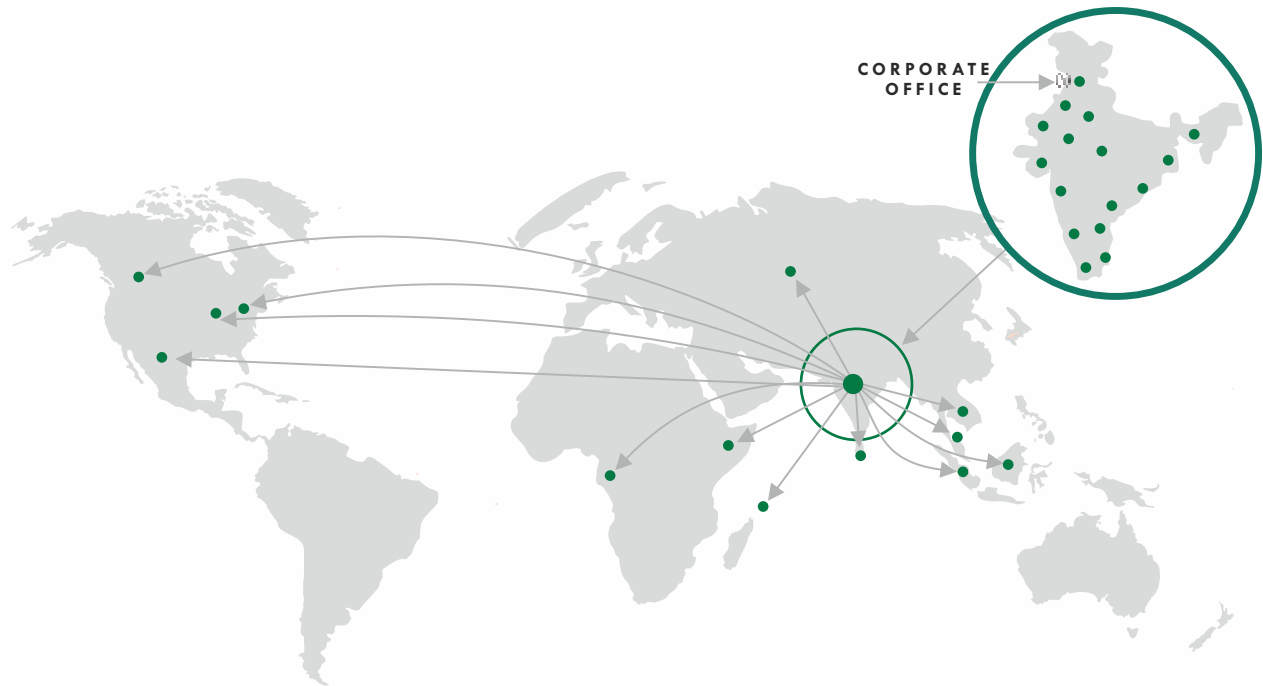

## Our Client Says....

*"We want to convey thanks for the assistance and support provided by SHREDO team and grateful with their quick services for installation of AFR Processing Plant at our site. They are highly professional & cooperative during installation and proving the performance guarantees."*

*(Mr. Steven)*

*"The Biomass Shredding System works extremely well at our site so we are very happy to use your company's product and services. The fine shredded material is perfect for feeding into our boiler and producing energy."*

*(Mr. Davinder Singh)*

*"Performance of SHREDO Shredding Machines has been found satisfactory and we wish them success in all their future endeavours. Efficient and cost effective solutions"*

*(Mr. Andrew)*

*"Technical and analytical capability of SHREDO team in process and operation of cement plants is good. We are extremely happy with the support provided by SHREDO team."*

*(Mr. Pankaj Kumar)*

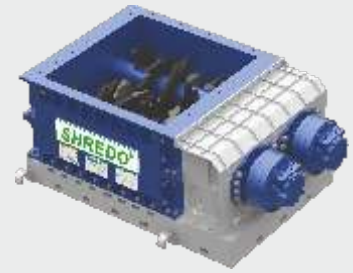
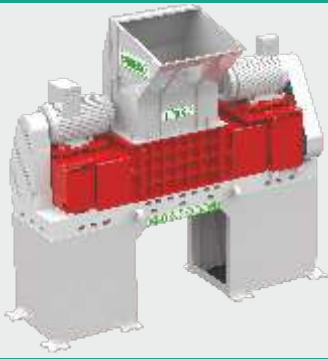

## LATEST DESIGN IN EVERY SHREDO'S SHREDDERS

**SHREDO waste size Reduction Solutions is builds to handle the many Applications:-** The SHREDO Shredder Components are manufactured and engineered in such a manner that they are capable to handle various kinds of rigorous operations easily and also ensure the consistent performance for years to come. Various SHREDO Components ranging from fabricated steel base to hexagonal Mulcher shafts all ensure reliable performance.

**Waste Product Destruction:-** No matter whether it is grimy or old, discarded or recalled stuff, these robust and capable our shredders wipe out all of your unnecessary used material. The package with or without Shrink/wrap any sort of paperboard, wood, drum, glass, metal and plastic etc.

**Waste Material reclaims:-** The main purpose of using our shredders is to recycle the ruined or imperfect items that can be used again. In the latest recycling process these components have extracted the dry granular material without much grime from the flawed cardboard containers. Furthermore additions applications for recovery is various contents like liquid, clinical, solid, chemical, tobacco and cosmetic products etc.

**SHREDO's SHREDDERS:-** IHL manufacture a full line of double shaft shredders in order to complete the certain operation necessities such as cutback in size, damaging the material to change the size of grimy for more advancement. IHL offer consistent and capable shredder models for the demands of different range of items from less size/ small item to bigger size/ huge items.

**Mulcher Shear Assembly:-** SHREDO® Mulchers are manufactured from High alloy heat treated processed steel to increase the product life span. The operations and product features decide the Mulcher design including width of Mulcher, hook reach and count of hooks. The location of the Mulchers in the cutting chamber can also be adjustable. This is done in the purpose to achieve the optimal "rip-shear" performance and the final product size.

**Automatic Reversal while Overload:-** While in system overloading process Shredders are provided with an automatic security system that pauses and reverses the shredding operation automatically. The shredder incorporated of this system empties itself by own and further automatically sustains the shredding action.

**Cost-effective:-** SHREDO shredders are constructed in such a way that they require lesser maintenance and provide more efficient performance while possessing with low speed high torque electromechanical drive and an exceptional chopping design.

**Trouble-free Operation:-** Shredder consists of various electronic characteristics like reverse start to automatic cleansing of Mulchers assembly.

**Noise free:-** The shredders are capable to perform action at low speed while high torque and without producing grime.

**Easy Installation :-** Comprising with modular design our machine covers up less space in the functional region.

**Minimum Maintenance:-** Shredo is constructed by using efficient parts, substantial design and others parts which enable them to produce flawless results and ensuring the longer consistency.

Double Gearbox driven, hexagonal/Square Mulcher shafts are architected for additional consistency and recourse by Spherical roller bearings.

**Customized Systems with Control:-** In case the products require an exclusive system due to their quantity and certain features then the system is comprised of middle sized shredder that works at low speed and huge torque. Then the shredding process begins to minimize the content into equal strips. The conveyor takes up the content to cutting hog working at large speed and converting the content into specific bit size. This machine is constructed in order to minimize and retrieve rubber piece that is produced from components given by the producer for the automotive trade. Each machine incorporates the control logic that controls the entire functionality of machinery.

**Material test facility prior to dispatch:-** We have specialized team of engineers that will analyze your stuff to determine the kind of shredding machine required to satisfy your needs.

The SHREDO's AFR Processing Plants are manufactured and engineered in such a manner that they are capable of shredding any kind of AFR available like MSW/RDF, Paint Sludge, Tyre, Plastic waste, Agro-waste, Textile waste, FMCG waste, Industrial waste, Rubber, Plastic Drums, Soft-drink Cane, Pharmaceutical waste, Wood waste, E-waste etc. in single Processing Plant.

**Effective Waste Product Destruction:** No matter whether it is grimy or old, discarded or re-called stuff, these robust Processing Plants are capable of wipe out things smoothly. These plants are capable of giving output in very small size in 3D with **output capacity range from 100TPD to 500TPD** or as per requirement.

**Effective Screening Arrangement:** Screening arrangement is synchronized with both Primary and Secondary Shredder to provide fine shredded output material under specified capacity, also lumps screening is possible with our incorporated system.

**Cost Effective:** The complete SHREDO's AFR Processing Systems are constructed in such a way that they require lesser maintenance and provide more efficient performance.

1. Feeding Hopper
2. Feeding Conveyor
3. Electro Magnetic Separator for Feeding Conveyor
4. SHREDO Shredder
5. Electro Magnetic Separator for output Conveyor
6. Output Conveyor
7. Disc Screen / Separator / Trommel
8. Fine Shreds Transfer Conveyor
9. Oversize Shreds Transfer Conveyor
10. Oversize Shreds Feeding Conveyor

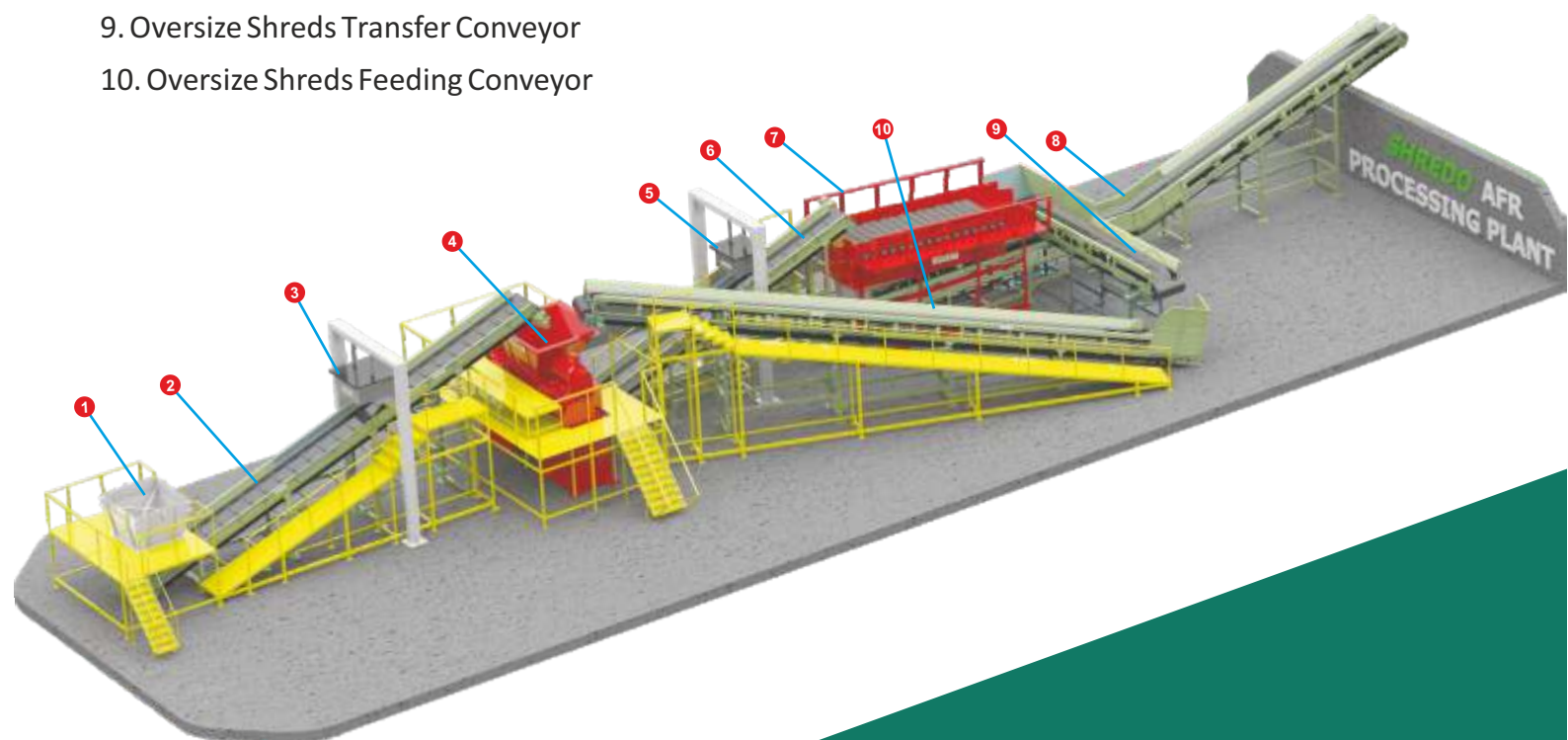





### More Over Plant consists features like

- Robust Shredding Machine
- Incorporated Magnetic Separation
- Minimum Maintenance
- Less Space requirement
- Noise free working
- Easy Installation
- Auto Reversal to Avoid Jamming
- Top Quality Conveyor Belts
- Ensure Fine Size Output

### ALTERNATIVE FUELS & RAW MATERIAL AFTER SHREDDING



# MSW SHREDDERS

## PRIMARY & SECONDARY SHREDDING SYSTEMS



### Features

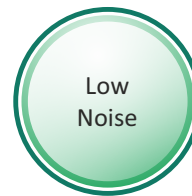
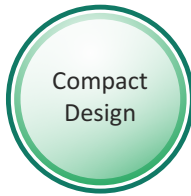

# RDF SHREDDERS

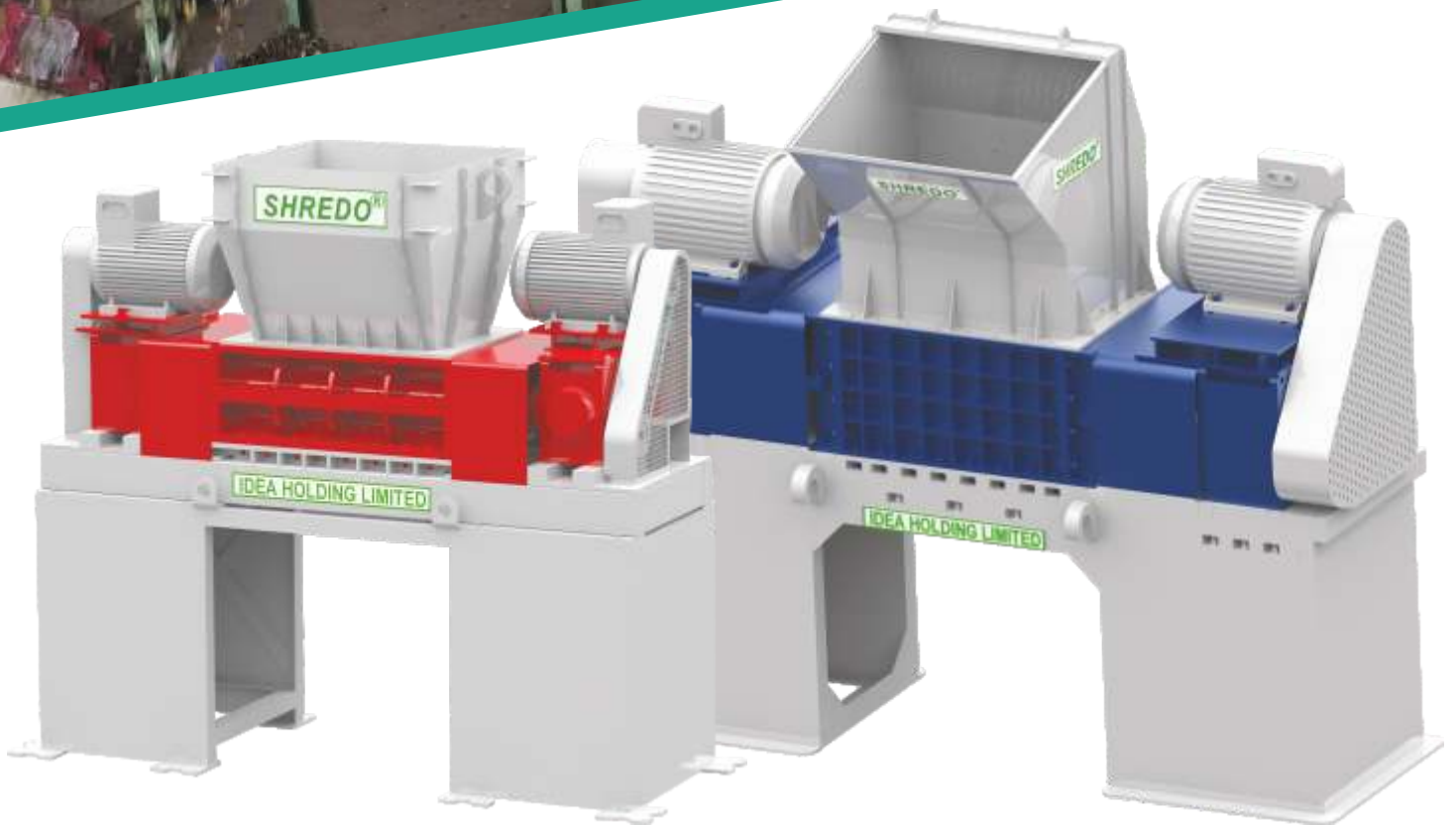

We are supplying MSW Shredders to our clients in variety of specifications, sizes, output capacity and particle size. Our MSW Shredders mainly used for recycling & processing of Municipal Solid Waste (MSW) includes almost every kind of waste material like Plastic, Hazardous, Industrial Waste and others. The main purpose of using our shredders is to recycle or reclaim the ruined or imperfect items and to generate revenue by using shredded material as an alternate energy source in the form of RDF (Refuse Derived Fuel). Our MSW Shredding systems can integrate screens, trommel, separators, conveyors, magnets for separating different materials present in the solid waste. These machines are worthy in waste management in your area and for municipal waste handling where the garbage disposal is the severe issue.

Capacity: 1 TPH, 3 TPH, 5 TPH, 10TPH, 15TPH, 20 TPH, 25 TPH, 30 TPH, 35TPH, 50 TPH, 60 TPH or as per Customer Requirements

Having spent a decade on converting the patented design into a product and conducting field trials, SHREDO has delivered one of the finest shredding machines to the customers that is said to be useful to shred various type farm residues such as Paddy Straw, Sugarcane Trash, Corn Stalk and others.

To fulfil the demand of our customers for fine output size alongwith required capacity, we designed and delivered Primary & Secondary Shredding Systems. These systems are useful to feed the raw material into all types of boilers installed in Power Plants, Ethanol Plants, Bio-fuel Plants and others.

Further, we also provide the customized solutions to our customer by listening and analysing the complete requirements.

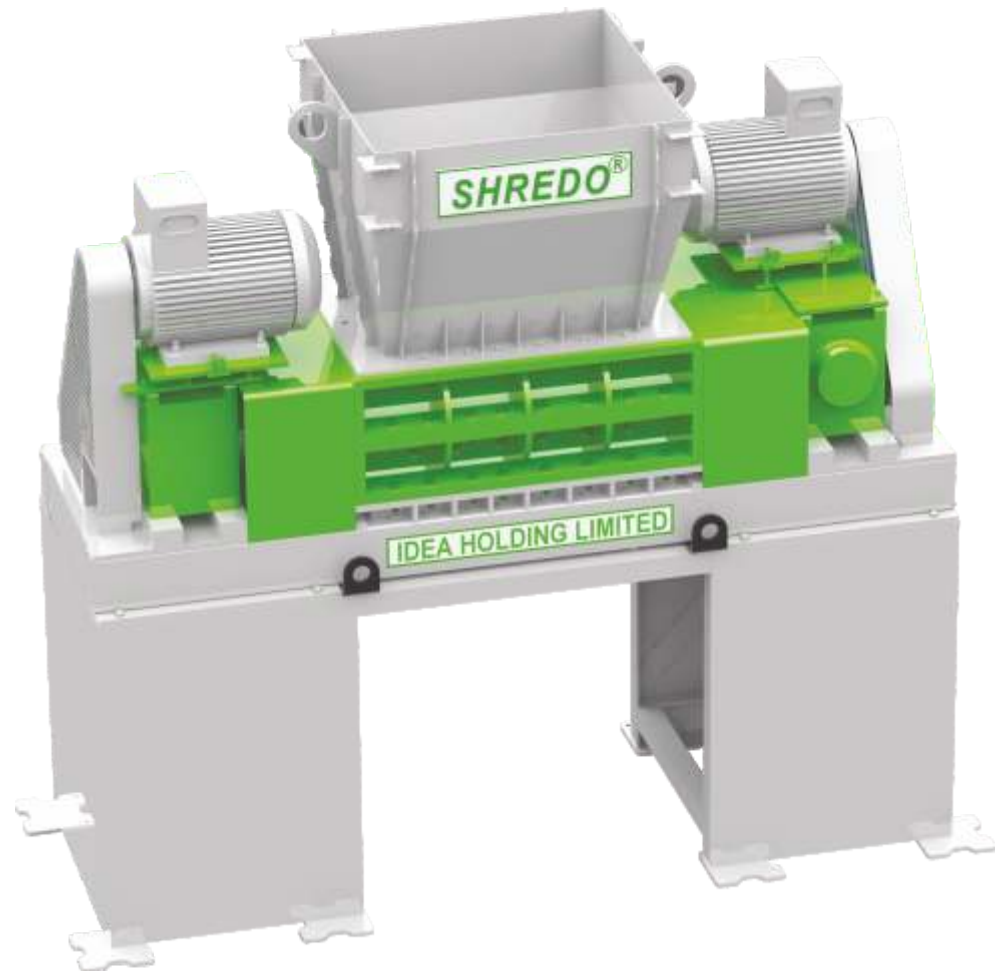

## Double Stage Bio-mass Shredding System

Capacity: 2-3 TPH, 5 TPH, 8-10TPH,  
15 TPH, 25 TPH, 35TPH  
or as per Customer Requirements



# PADDY STRAW SHREDDER



With an increased proportion of technology, we are manufacturing and supplying a qualitative assortment of Paddy Straw Shredders for shredding the Rice Paddy Straw Bales. Designed and manufactured with utmost precision, the offered shredders are assembled using elevated raw material as per the set industry norms. In addition to this, our offered range is dimensionally accurate and undergoes various tests under the supervision of our experienced quality controllers to ensure the flawlessness of the products.

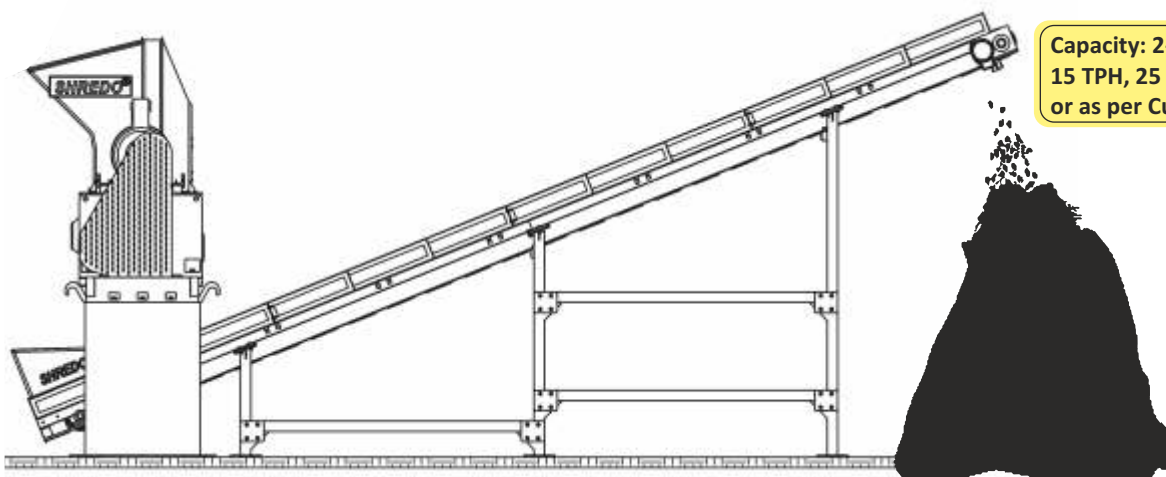
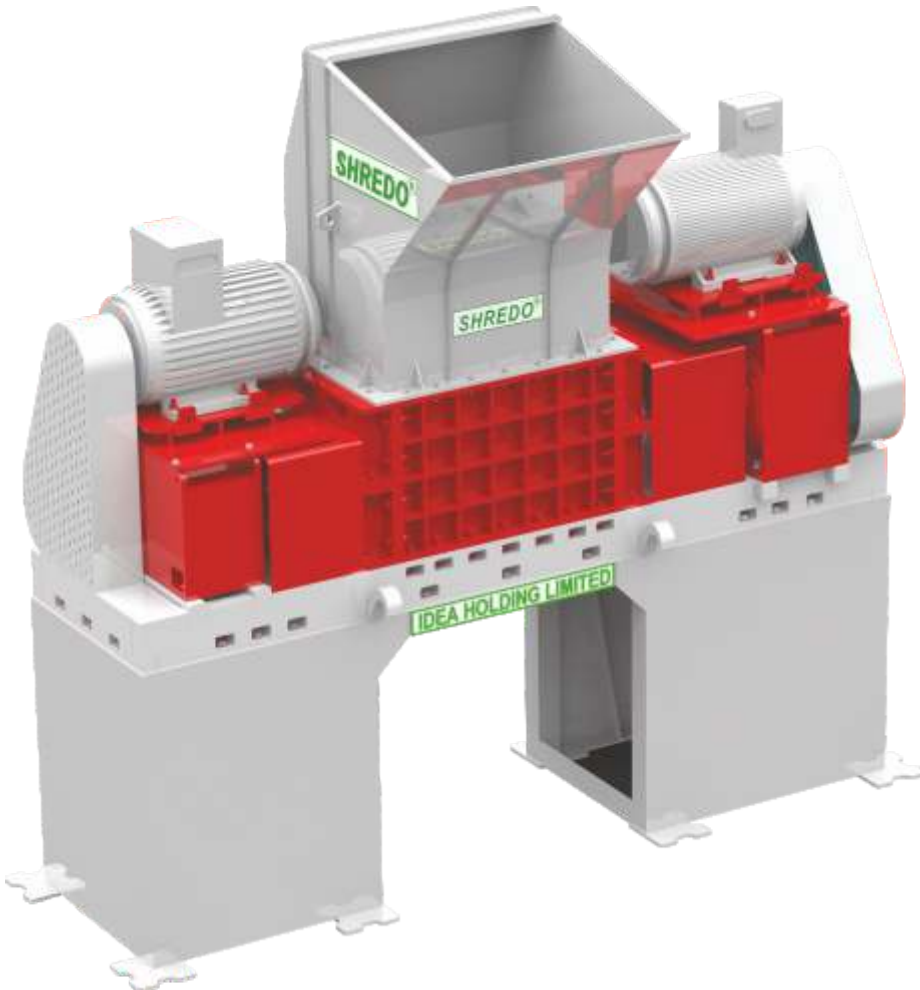

Capacity: 2-3 TPH, 5 TPH, 8-10TPH,  
15 TPH, 25 TPH, 35TPH  
or as per Customer Requirements

# SUGARCANE TRASH SHREDDER



SHREDO Shredders are a modern technology, robust and compact in design, used for shredding of Sugarcane Trash Bales into small pieces in various Power Plants in the world. Our Shredders work on high torque and low speed shear technology which converted the farm waste into energy.

The shockproof blades with chamber body made up of high tensile alloy steel provide high output and efficiency to the machines to perform rigorous operations on load. We are using premium brand Motors, VFD, Bearings and other component for our shredding machines.

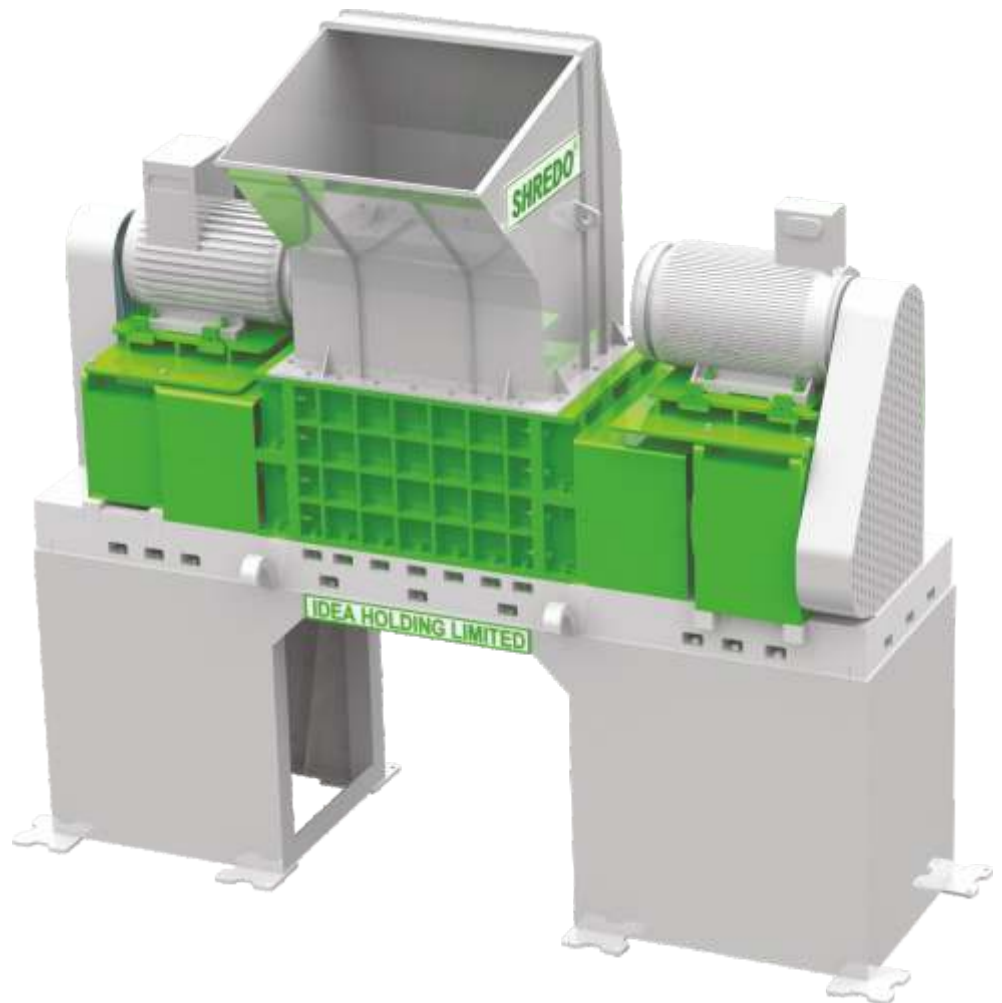

## Features

Prolonged  
Service Life

Compact  
Design

Less  
Maintenance

Low  
Noise

Energy  
Efficient

Capacity  
2 to 35 TPH

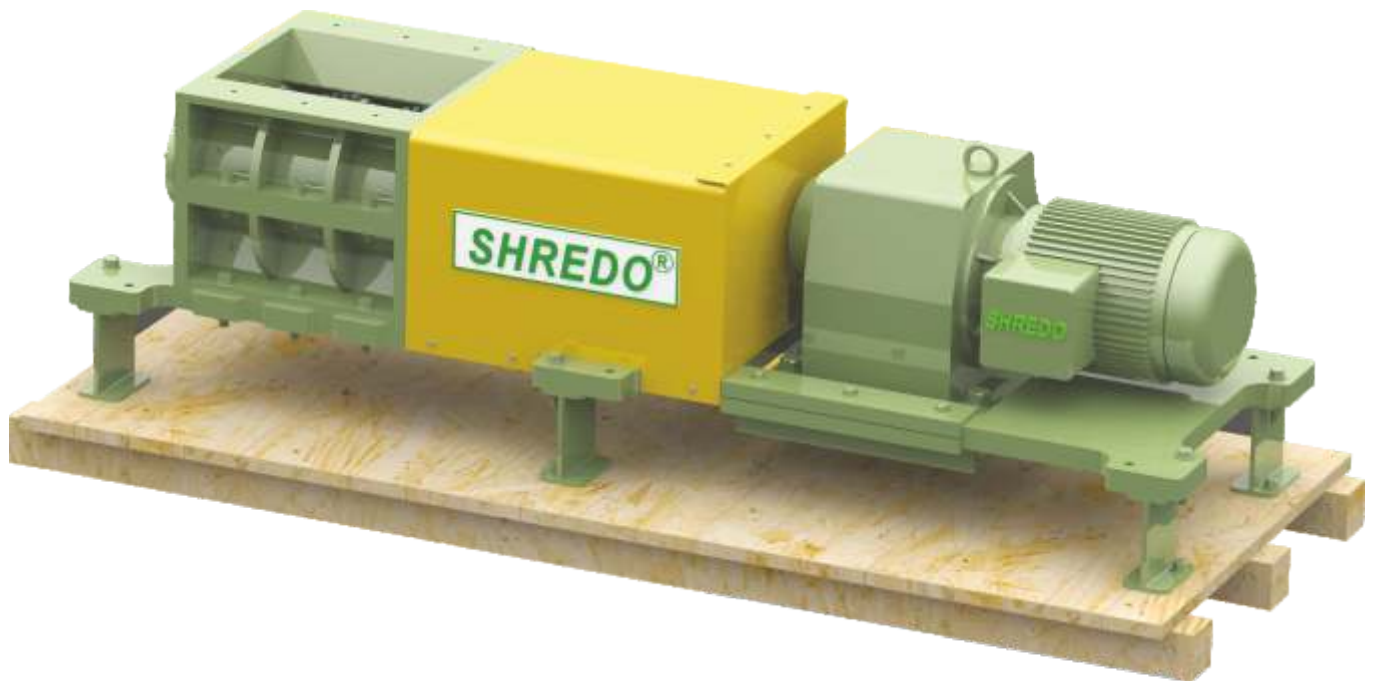

## FEATURES

- ◆ Capacity 1 - 25 TPH.
- ◆ Auto Reverse while it has overload/Jam.
- ◆ Easy to clean machine from advance control panel.
- ◆ High Shredding Mulcher Life
- ◆ Cutter plate material is alloy steel and hock proof.
- ◆ Hooper made up of 8-10mm plate
- ◆ Our shaft material is AISI 4340 for long life.
- ◆ We are using Hexagonal Dimension for more strength.
- ◆ Chamber is made up to high tensile casting with 70mm thickness of wall.
- ◆ All the bearing are SKF/FAG.
- ◆ All Gearbox are of ELECON/GREAVES, PREMIUM brand.
- ◆ We are having Local Panel with underground wiring for both the motors.
- ◆ It gives safety to worker from shock.
- ◆ We are using gear coupling for continues working on heavy load.
- ◆ There is no sound while working of the machine.
- ◆ It is easily repairable while replacing the cutter plates.

# WOOD SHREDDERS



Backed with modern infrastructural facilities, we have marked a reputed position in the industry as the foremost manufacturer and exporter of Wood Shredder. These machine are supplied mainly to furnitur industries for shredding the waste wooden products. We manufacture these shredding machine using superior grade steel, wisely procured from the well-known vendors present in the industry-our in-house analyst team stringently inspect this Wood Shredder on standard quality parameters of quality ensure its smooth functioning.



## FEATURES

- ◆ Our Shredder is available in different capacities and specifications to meet the clients' divers requirements.
- ◆ The machine are robust in construction and durable in quality.
- ◆ Offered machine is quite easy to operate with automatic functions.





# EMPTY FRUIT BUNCH

Shredo Empty Fruit Bunch Shredder is also called the bunch breaker and oil squeeze is actually a compressed and bulky device used to deal with the empty fruit bunch material efficiently. The end product by the EFB Shredder is very useful for different purposes like production of energy, mulching, biodegradable manures, and pelletizing. The EFB is crushed into tiny fibbers in the separate parts. Within the shredding of material, the oil and water is pressed out which is then sent to oil recovery parts of the machine.



Capacity  
2 to 30 TPH



# TEXTILE SHREDDER



Having core competency in this domain, we are engaged in manufacturing, exporting and supplying a broad spectrum Fabric / Textile Shredder. In order to cut longer fiber threads into smaller into smaller size for further recycling process, this shredder is demanded into textile industries. By utilizing progressive techniques, this shredder is manufactured in numerous specifications under the strict Vigilance of adept professionals'. Available at affordable price range, the offered Fabric Shredder can be bought from us within promised time-frame

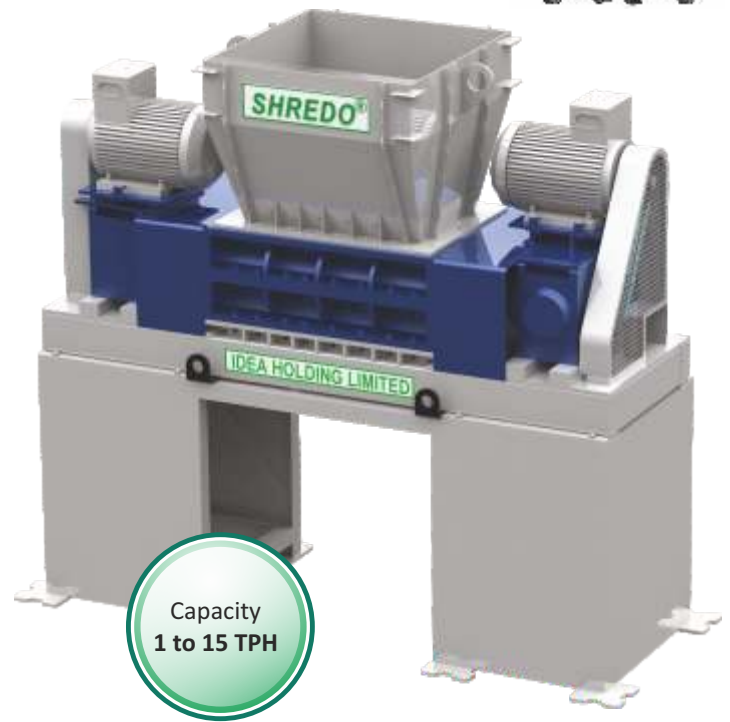

# MEDICAL WASTE SHREDDER

Leveraging on our high-tech unit, we are able to manufacture, export and supply a huge range of medical Waste Shredder. Extensively used for treating and recycling various medical wastes like bags, gloves, syringes and plastic sheet, this shredder is widely appreciated in recycling plants. Our Medical Waste Shredder is equipped with adjustable knives, durable motors and gear boxes in addition, we offer this shredder to the clients at the nominal prices in variety of specifications.



# HAZARDOUS WASTE SHREDDER



Bringing forth the best waste management solution in industry, we are manufacturing and exporting highly functional range of Hazardous Waste Shredders. These machines are capable of shredding any kind of hazardous waste materials generated from different industries. All these Shredding Machines are wisely manufactured keeping in mind the environmental concerns. We make available these Hazardous Waste Shredders to clients in both standard as well as customized models to meet their specific application requirements.

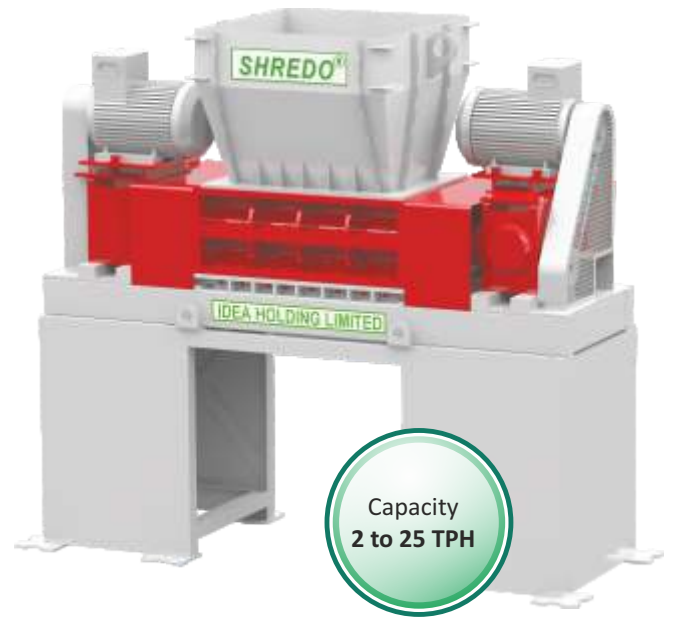

# PLASTIC WASTE SHREDDER

Promoting the re-use materials, we manufacture and export an excellent stock of Plastic Shredder. These machine effectively cut the cost of industries by generating plastic from waste materials. Widely use for Shredding waste plastic products., these machine are robust and rust proof in construction. Our clients can easily get these Plastic Shredders from us in different capacities and configurations as per their industrial requirements.

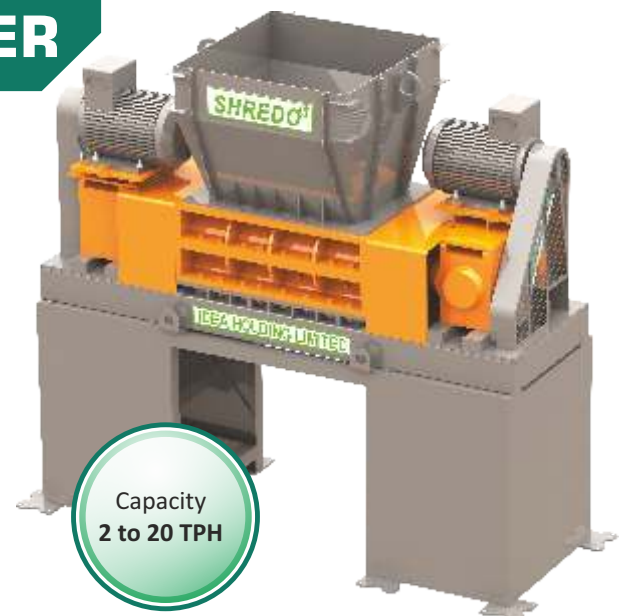

# METAL SCRAP SHREDDER



The Metal Scrap Shredder precisely shreds the metal waste. The shredding machines are highly powerful to handle the window frames, Door, steel drums, Tins, HSM 1, Metal scraps and various other types of metallic accessories. The low speed and large orque shredder efficiently shred the metallic scraps into fine size metallic parts that save your extra cost on the volume reduction before the recycling and reuse.

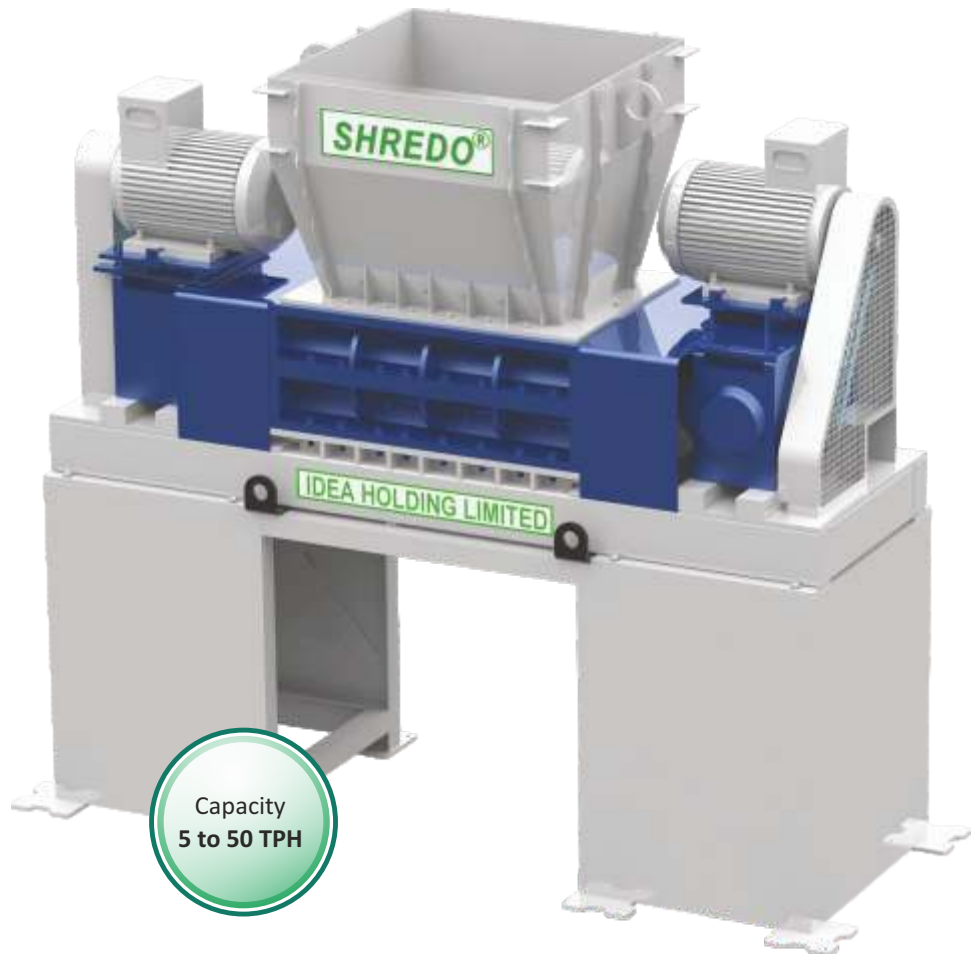

Capacity  
5 to 50 TPH



# E-WASTE SHREDDER

The E-waste shredder plays a vital role in E-waste management as it shreds the non usable E-materials like CD,s DVD,s hard drives, Keyboards, washing machine, fridge, and damaged computer parts etc. Shredo shred E-waste materials to the core level that the information stored on the devices can't be retrieved. The shredder processes the hard drives in the most protective way. To handle the bulky devisees like monitors, printers, and ink cartridges primary and secondary shredders are used.

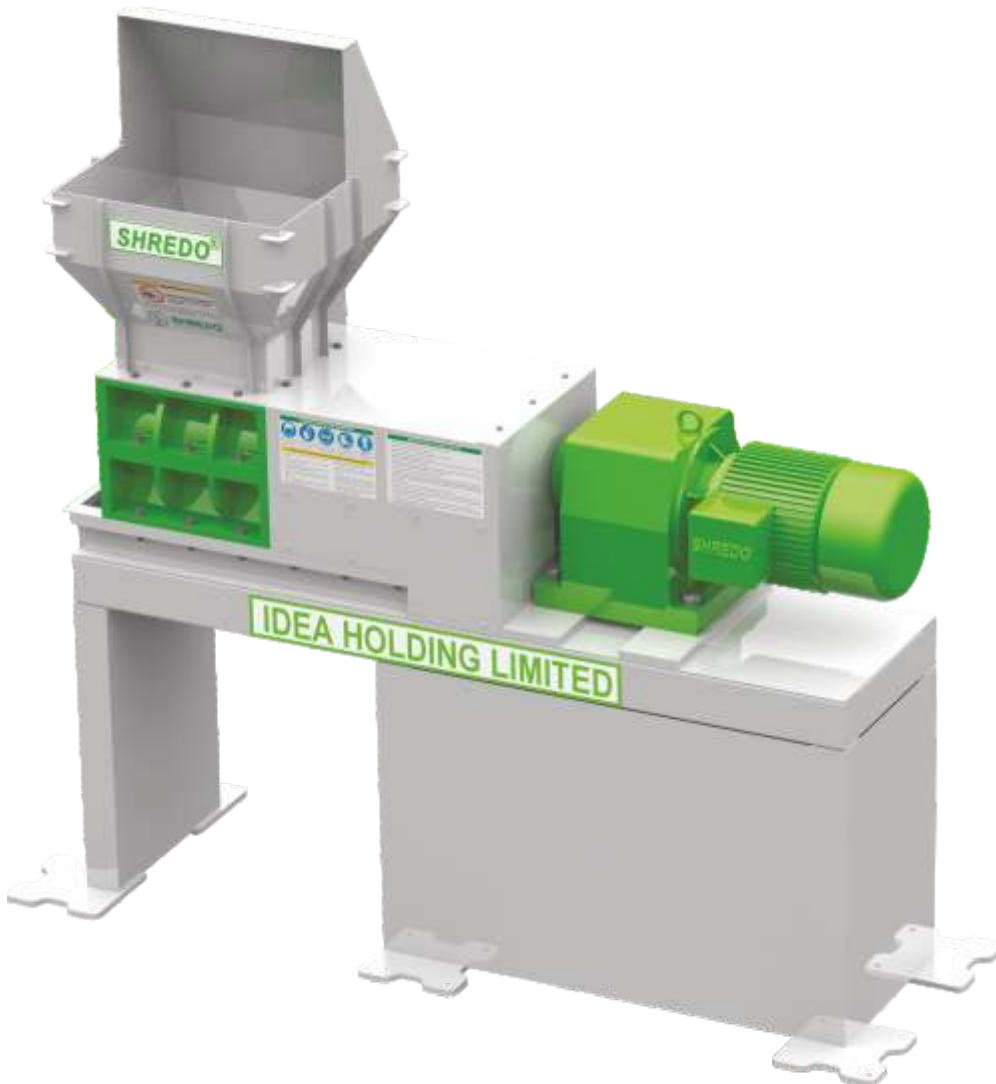

## FEATURES

Corrosion resistant body

Durable Service life

Less Maintenance

Robust finish with high strength

Capacity 1 to 10 TPH

# SUPER CHOPPER



SHREDO Super Chopper is used for the initial size reduction, reducing the complete tyre to a shred after which it can be processed for Granulation. The pre-chopper is also used to increase the capacity of the plant as a whole and to make sure that there is always sufficient product to go through the line keeping up the capacity.

The Super Chopper is equipped with Variable Frequency Drive and PLC System for complete automation and reduces the energy consumption. The super chopper can shred the complete tyres and the customers can purchase this complete system from us on very competitive prices.

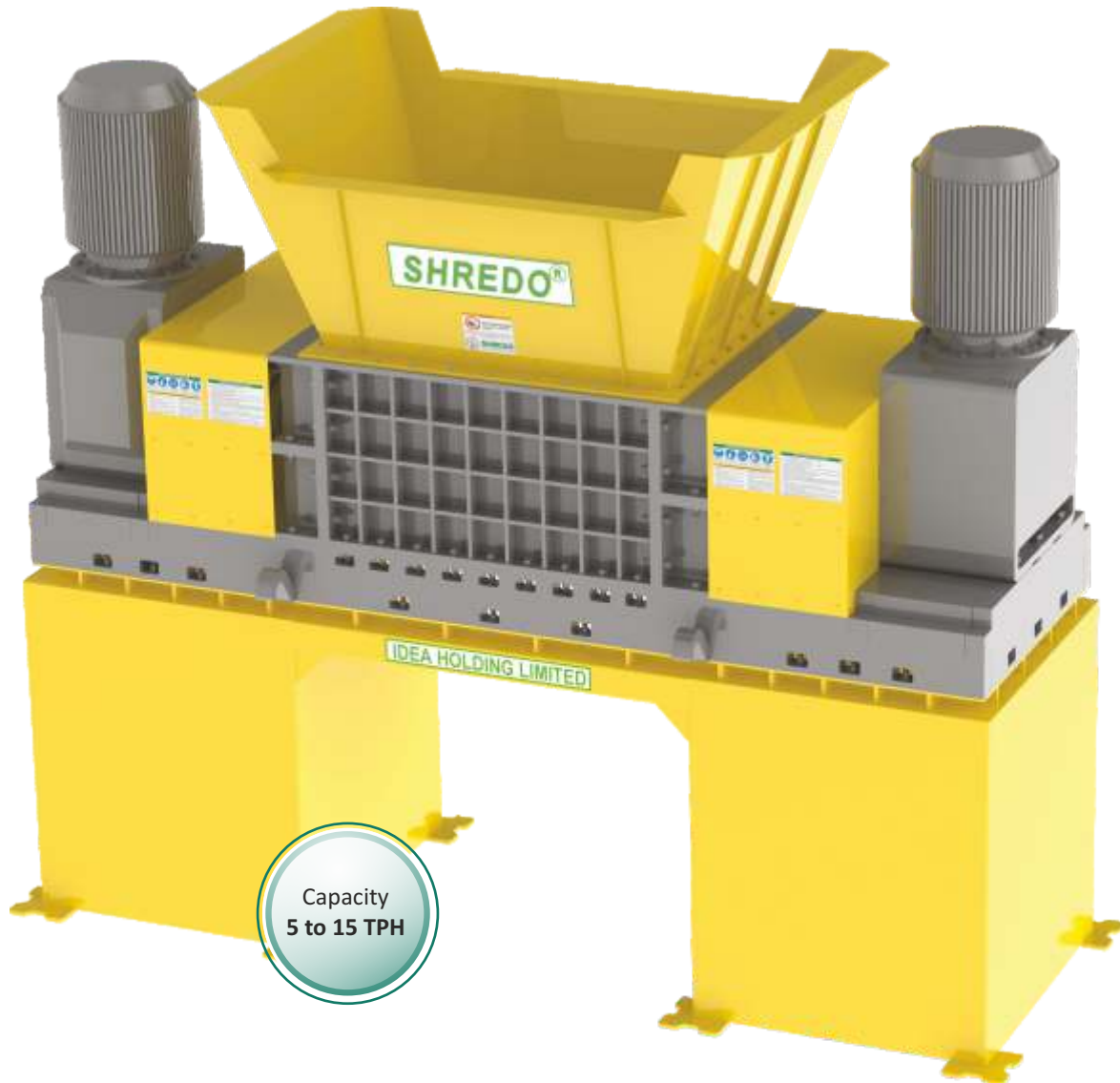

WASTE TYRE



SHREDDING



TYRE SHREDS

With sincere intentions to expand our business all across the globe, we are engaged in putting forth the best quality array of Tyre Granulator. The offered is manufactured with the use of premium quality components and highly advance techniques. These Granulator designed to process scrap Tyres for recycling and re-purposing for a variety of applications. Widely used to make tyre granules of different kinds of Tyres. Beside all, our clients can purchase these Granulator at highly competitive prices from us.

## Features

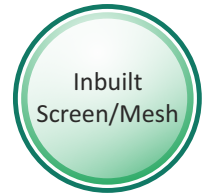
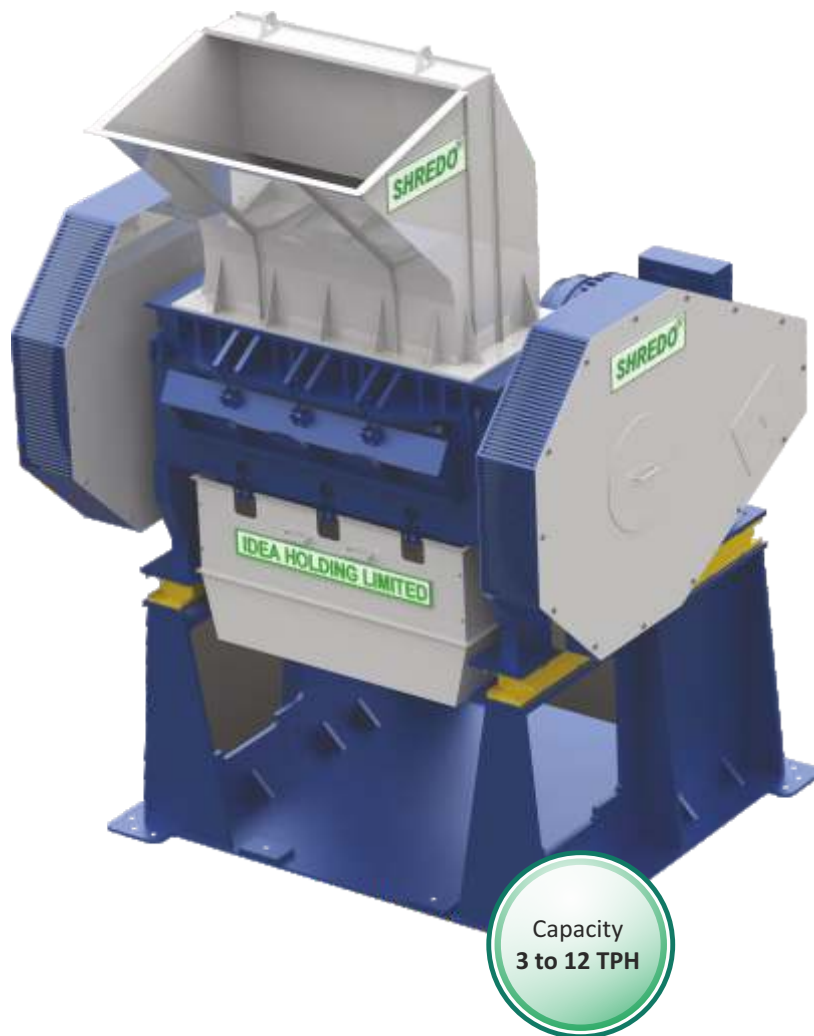

**GRANULATOR**



**RUBBER GRANULES**

# PAPER SHREDDING & BRIQUETTING



The Shredding Section is mainly a disintegration process where Pre-Crusher is for destroying & breaking the input, and high speed rotating knives of Rasper/Granulator with classifying screen for ensuring the shredded pieces are smaller than requirement. Thereafter Shred Extraction system conveys the shreds through quality Ductwork into Storage Hopper which is equipped with Stirring Mechanism. The shreds fall down into the hopper and the air is blown out through Shred Separators/HEPA Filters. Our Shredding System can handle all types of waste such as Paper, Magazines, Cardboard with Stapler Pins, Security Paper, Files, Banknote, Books and other paper waste.





# PAPER SHREDDING & BRIQUETTING



Hydraulic Briquette Presses compress the end output shreds in form of high density briquettes without mixing any adhesive or water in fully automatic manner and such that these can easily be transported without spillage and stored. The entire system of Paper Shredding and Briquetting can be easily controlled by one Central Control Panel integrated with VFD, PLC, HMI and SCADA System

Capacity of Paper Shredding & Briquetting Plant :  
200 kg/h to 1200 kg/h or as per Customer Requirement



A dedicated team of highly qualified and experienced service engineers is available to handle service activities globally who offer online and onsite services. To ensure short turnaround time, service engineers are deployed at various locations. The company has well managed dedicated spare parts inventory in factory to delivery the parts at the shortest possible time. The spare parts division is managed by experienced technicians to help customer to identify the correct parts numbers of even very old machinery so that only the correct parts leave the factory.

## Spare Parts



# CLIENT LIST

## OIL & GAS SECTOR



## BIOMASS SECTOR



## CEMENT INDUSTRIES SECTOR



## MSW SECTOR



*Welcome Your Name Here*



TROMMEL



CONVEYOR



METAL DETECTOR

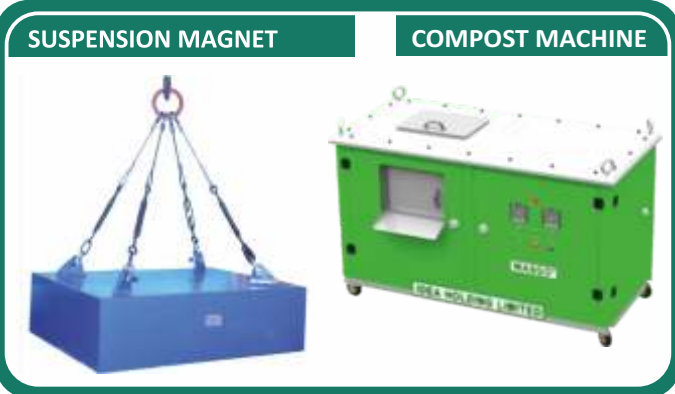

SUSPENSION MAGNET

COMPOST MACHINE



INDIA'S FIRST & LEADING SHREDDER MANUFACTURER



SHREDO PRIMARY & SECONDARY SHREDDING SYSTEM

## IDEA HOLDING LIMITED

AN ISO 9001:2015 CERTIFIED COMPANY

MFG. OF HEAVY DUTY SHREDO SHREDDING MACHINES & SYSTEMS

SHREDO Chowk, C-203A, Phase-VII Focal Point, Ludhiana-141010, Punjab (INDIA)

Ph. No. : +91-161-4628199, 2521012 (HOTLINE)

+91 98152 74547, +91 98152 51219

E-mail : [shredo@ideamails.com](mailto:shredo@ideamails.com), [shredomachine@gmail.com](mailto:shredomachine@gmail.com)

[www.ShredoRecycling.com](http://www.ShredoRecycling.com) | [www.ShredderVideo.com](http://www.ShredderVideo.com)

