

T-50H

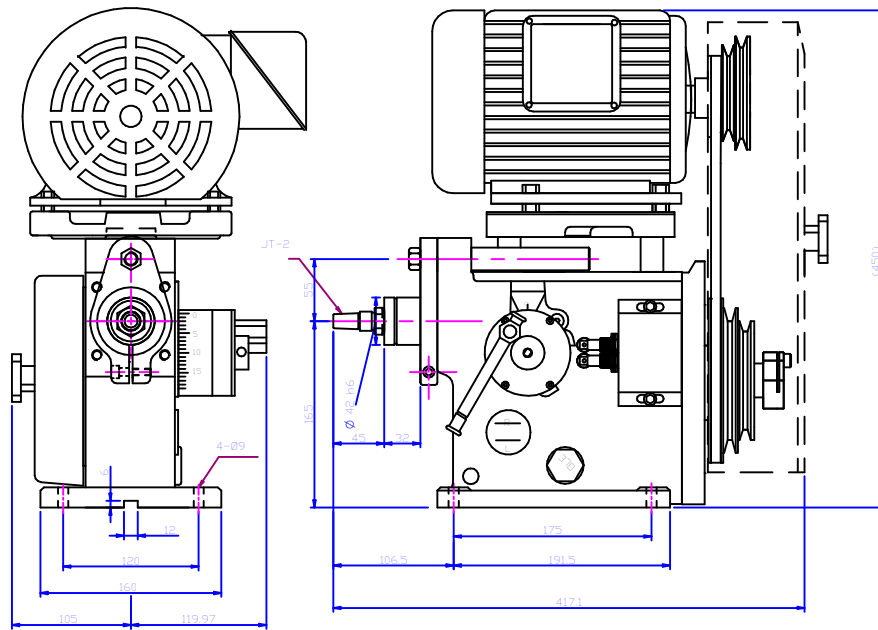

Max. Tapping Capacity	M8(S45C)	Weight	52KG
Spindle Taper	JT-2	Spindle Stroke	45M/M
Motor	0.75KW,4P	Spindle Speed	Optiona : 420 / 760 / 1340RPM(50HZ)
Leadserew Pitch Range	P0.5-P1.5		500 / 900 / 1600RPM(60HZ)
Wearing Parts			
Spindle Bearing	6202VV*1 , 6003DDU*1	Belt	M-Belt
Pully Bearing	6204DDU*2 , NU204*1		
Oil Seal - Front Cover	TC-42*60*9 *1		
Limit Switch	7311x2		