

T-80H

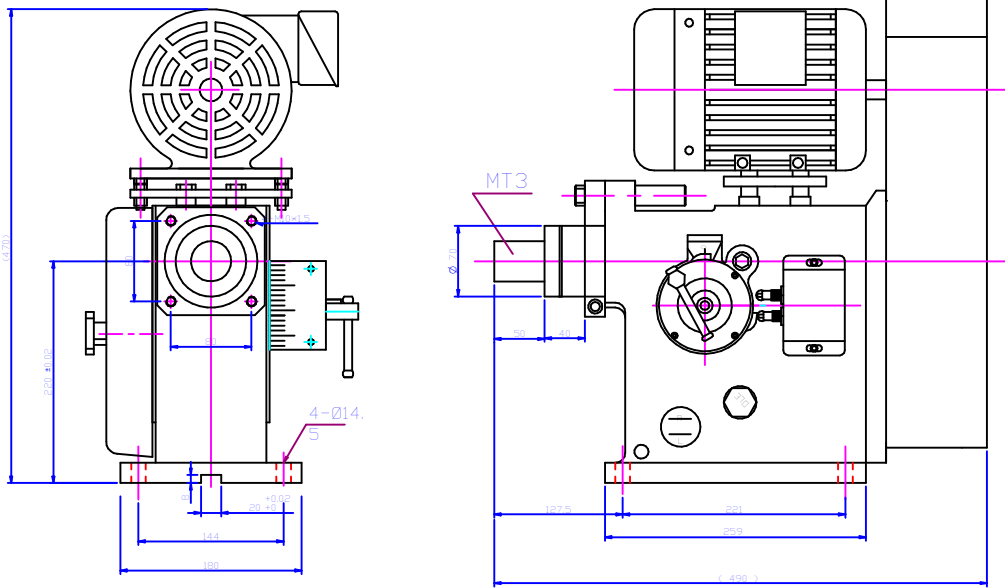

Max. Tapping Capacity	M16(S45C)	Weight	85KG
Spindle Taper	MT-3	Spindle Stroke	55M/M
Motor	1.5KW,4P	Spindle Speed	Optiona : 155 / 285 / 515RPM(50HZ)
Leadserew Pitch Range	P0.5-P2.0		190 / 340 / 620RPM(60HZ)
<b>Wearing Parts</b>			
Spindle Bearing	32006*1 , 6205DDU*1	Belt	B-Belt
Pully Bearing	6205DDU*2 , NU205*1		
Oil Seal - Front Cover	TC-70*95*13 *1		
Limit Switch	7311*2		