

T-90H

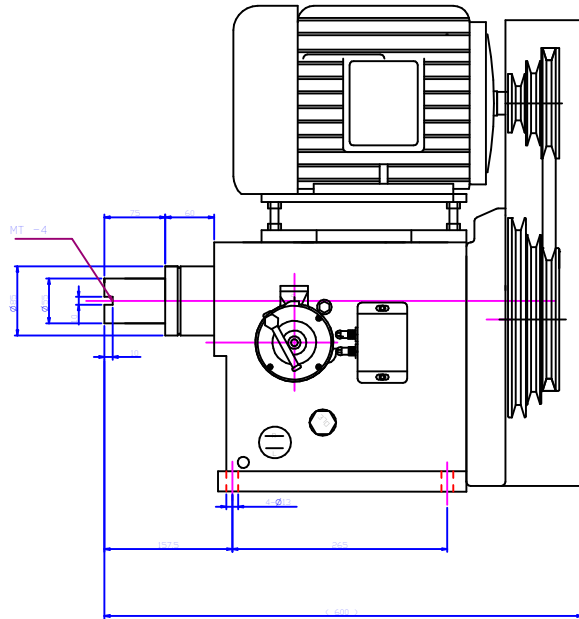
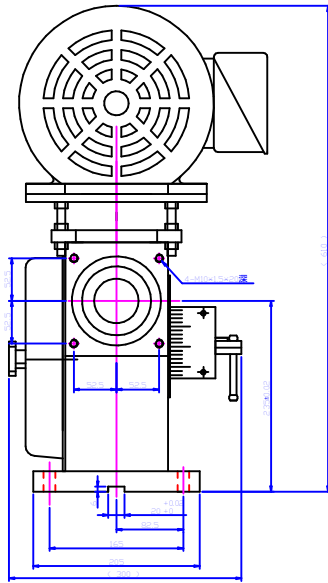

Max. Tapping Capacity	M30(S45C)	Weight	120KG
Spindle Taper	MT-4	Spindle Stroke	55M/M
Motor	2.2KW,6P	Spindle Speed	Optiona : 85 / 170 / 250RPM(50HZ)
Leadserew Pitch Range	P0.5-P3.0		100 / 200 / 300RPM(60HZ)
Wearing Parts			
Spindle Bearing	6007DDU*1 , 6008DDU*1 ,6009DDU*1	Belt	B-Belt
Pully Bearing	6206DDU*2 , NU206*1		
Oil Seal - Front Cover	TC-85*110*12*1		
Limit Switch	7311*2		