



**APEX PRECISION
MECHATRONIX PVT.LTD.**

303-308, Krishna Bhuvan Annex, 22-B, Govandi
Station Road, Deonar, Mumbai - 400088,
Maharashtra,
INDIA.

PHONE NO.

61464444 / 9967550131

EMAIL

sales@apexprecision.co.in

Model LMK

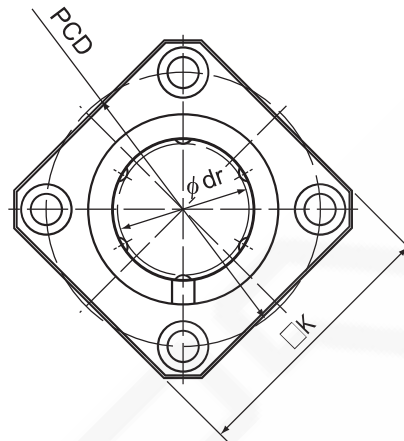

Model LMK

Model No.	Ball rows	Main dimensions							
		Inscribed bore diameter		Outer diameter		Length		Flange diameter	
		dr	Tolerance	D	Tolerance	L	Tolerance	D ₁	Tolerance
LMK 6	4	6	0 -0.009	12	0 -0.011	19	0 -0.2	28	0 -0.2
LMK 8S	4	8		15		17		32	
LMK 8	4	8		15		24		32	
LMK 10	4	10		19	29	39			
LMK 12	4	12		21	30	42			
LMK 13	4	13		23	32	43			
LMK 16	5	16	28	37	48	0 -0.10			
LMK 20	5	20	32	42	54				
LMK 25	6	25	40	59	62				
LMK 30	6	30	45	64	74				
LMK 35	6	35	52	70	82				
LMK 40	6	40	60	80	96				
LMK 50	6	50	80	100	116	0 -0.3			
LMK 60	6	60	90	110	134				

Note) Since this model contains a synthetic resin retainer, do not use it at temperature exceeding 80°C.
If requiring a type equipped with a seal, indicate it when placing an order.

(Example) LMK13 UU

Seal attached on both ends of the nut

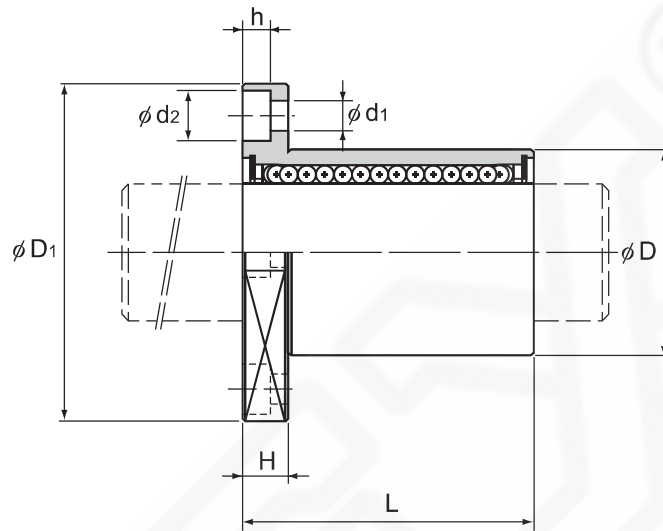

Unit: mm

	K	H	PCD	Mounting hole $d_1 \times d_2 \times h$	Flange perpendicularity μm	Eccentricity (max) μm	Radial clearance tolerance μm	Basic load rating		Mass g
								C N	C_0 N	
	22	5	20	$3.4 \times 6.5 \times 3.3$	12	12	-5	206	265	17
	25	5	24	$3.4 \times 6.5 \times 3.3$	12	12	-5	176	225	25
	25	5	24	$3.4 \times 6.5 \times 3.3$	12	12	-5	265	402	26
	30	6	29	$4.5 \times 8 \times 4.4$	12	12	-5	373	549	45
	32	6	32	$4.5 \times 8 \times 4.4$	12	12	-5	412	598	50
	34	6	33	$4.5 \times 8 \times 4.4$	12	12	-7	510	775	67
	37	6	38	$4.5 \times 8 \times 4.4$	12	12	-7	775	1180	105
	42	8	43	$5.5 \times 9.2 \times 5.4$	15	15	-9	863	1370	130
	50	8	51	$5.5 \times 9.2 \times 5.4$	15	15	-9	980	1570	270
	58	10	60	$6.6 \times 11 \times 6.5$	15	15	-9	1570	2750	344
	64	10	67	$6.6 \times 11 \times 6.5$	20	20	-13	1670	3140	487
	75	13	78	$9 \times 14 \times 8.6$	20	20	-13	2160	4020	790
	92	13	98	$9 \times 14 \times 8.6$	20	20	-13	3820	7940	1705
	106	18	112	$11 \times 17.5 \times 10.8$	25	25	-13	4710	10000	2278

Note) If an oil hole is required, this can be indicated by appending "OH" to the end of the model number.
For further information, contact THK.

Model LMK-M (Stainless Steel Type)

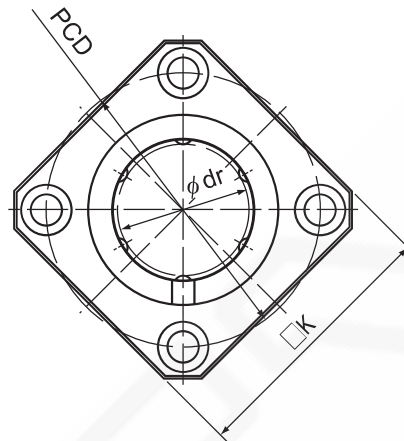

Model LMK-M

Model No.	Ball rows	Main dimensions							
		Inscribed bore diameter		Outer diameter		Length		Flange diameter	
		dr	Tolerance	D	Tolerance	L	Tolerance	D ₁	Tolerance
LMK 6M	4	6	0 -0.009	12	0 -0.011	19	0 -0.2	28	0 -0.2
LMK 8SM	4	8		15		17		32	
LMK 8M	4	8		15		24		32	
LMK 10M	4	10		19	29	39			
LMK 12M	4	12	21	30	42				
LMK 13M	4	13	23	32	43				
LMK 16M	5	16	28	37	48				
LMK 20M	5	20	0 -0.010	32	0 -0.016	42	54		
LMK 25M	6	25		59		62			
LMK 30M	6	30		45	64	74			

Note) Since this model contains a synthetic resin retainer, do not use it at temperature exceeding 80°C.
If requiring a type equipped with a seal, indicate it when placing an order.

(Example) LMK25M UU

Seal attached on both ends of the nut

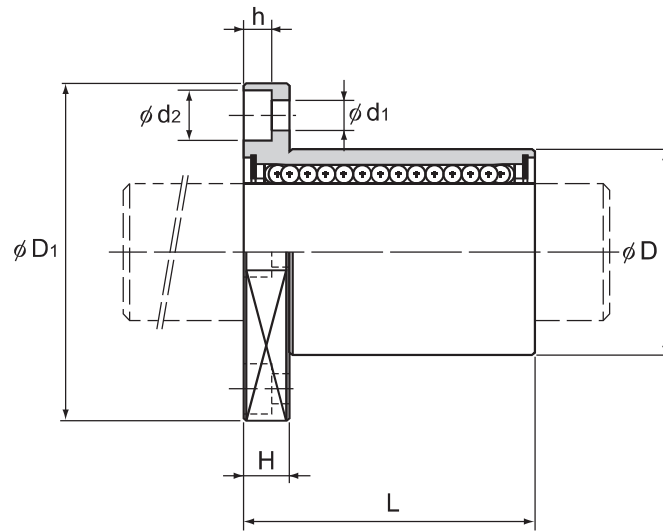

Guide Ball Bushing/Linear Bushing

Unit: mm

	K	H	PCD	Mounting hole $d_1 \times d_2 \times h$	Flange perpendicularity μm	Eccentricity (max) μm	Radial clearance tolerance μm	Basic load rating		Mass g
								C N	C_0 N	
	22	5	20	$3.4 \times 6.5 \times 3.3$	12	12	-5	206	265	17
	25	5	24	$3.4 \times 6.5 \times 3.3$	12	12	-5	176	225	25
	25	5	24	$3.4 \times 6.5 \times 3.3$	12	12	-5	265	402	26
	30	6	29	$4.5 \times 8 \times 4.4$	12	12	-5	373	549	45
	32	6	32	$4.5 \times 8 \times 4.4$	12	12	-5	412	598	50
	34	6	33	$4.5 \times 8 \times 4.4$	12	12	-7	510	775	67
	37	6	38	$4.5 \times 8 \times 4.4$	12	12	-7	775	1180	105
	42	8	43	$5.5 \times 9.2 \times 5.4$	15	15	-9	863	1370	130
	50	8	51	$5.5 \times 9.2 \times 5.4$	15	15	-9	980	1570	270
	58	10	60	$6.6 \times 11 \times 6.5$	15	15	-9	1570	2750	344

Note) Since the nut and the balls use stainless steel, these models are highly resistant to corrosion and environment.
If an oil hole is required, this can be indicated by appending "OH" to the end of the model number.
For further information, contact THK.

Model LMK-L

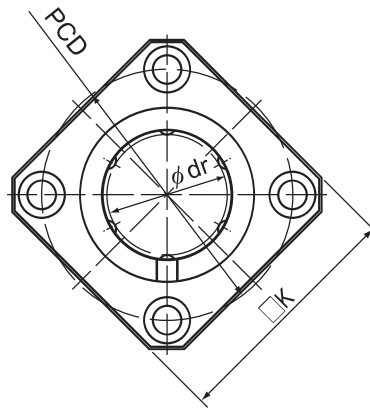

Model LMK-L

Model No. Standard type	Ball rows	Main dimensions							
		Inscribed bore diameter		Outer diameter		Length		Flange diameter	
		dr	Tolerance	D	Tolerance	L	Tolerance	D ₁	Tolerance
LMK 6L	4	6	0 -0.010	12	0	35	0 -0.3	28	0 -0.2
LMK 8L	4	8		15	-0.013	45		32	
LMK 10L	4	10		19	0	55		39	
LMK 12L	4	12		21	-0.016	57		42	
LMK 13L	4	13		23	0	61		43	
LMK 16L	5	16		28	0	70		48	
LMK 20L	5	20	32	0	80	54	0 -0.3		
LMK 25L	6	25	40	-0.019	112	62			
LMK 30L	6	30	45	0	123	74			
LMK 35L	6	35	52	0	135	82			
LMK 40L	6	40	60	-0.022	154	96			
LMK 50L	6	50	80	0	192	116			
LMK 60L	6	60	90	-0.025	211	134	0 -0.3		

Note) Since this model contains a synthetic resin retainer, do not use it at temperature exceeding 80°C.
If requiring a type equipped with a seal, indicate it when placing an order.

(Example) LMK50L UU

Seal attached on both ends of the nut

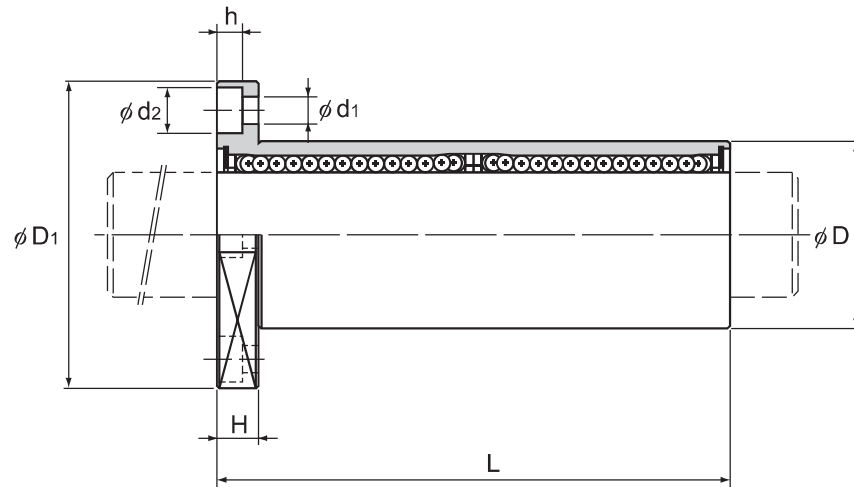

Guide Ball Bushing/Linear Bushing

Unit: mm

	K	H	PCD	Mounting hole $d_1 \times d_2 \times h$	Flange perpendicularity μm	Eccentricity (max) μm	Radial clearance tolerance μm	Basic load rating		Mass g
								C N	C_0 N	
	22	5	20	$3.4 \times 6.5 \times 3.3$	15	15	-5	324	529	24
	25	5	24	$3.4 \times 6.5 \times 3.3$	15	15	-5	431	784	39
	30	6	29	$4.5 \times 8 \times 4.4$	15	15	-5	588	1100	68
	32	6	32	$4.5 \times 8 \times 4.4$	15	15	-5	657	1200	76
	34	6	33	$4.5 \times 8 \times 4.4$	15	15	-7	814	1570	100
	37	6	38	$4.5 \times 8 \times 4.4$	15	15	-7	1230	2350	176
	42	8	43	$5.5 \times 9.2 \times 5.4$	20	20	-9	1400	2750	210
	50	8	51	$5.5 \times 9.2 \times 5.4$	20	20	-9	1560	3140	466
	58	10	60	$6.6 \times 11 \times 6.5$	20	20	-9	2490	5490	569
	64	10	67	$6.6 \times 11 \times 6.5$	25	25	-13	2650	6270	825
	75	13	78	$9 \times 14 \times 8.6$	25	25	-13	3430	8040	1321
	92	13	98	$9 \times 14 \times 8.6$	25	25	-13	6080	15900	2952
	106	18	112	$11 \times 17.5 \times 10.8$	25	25	-13	7650	20000	3883

Note) If an oil hole is required, this can be indicated by appending "OH" to the end of the model number.
For further information, contact THK.

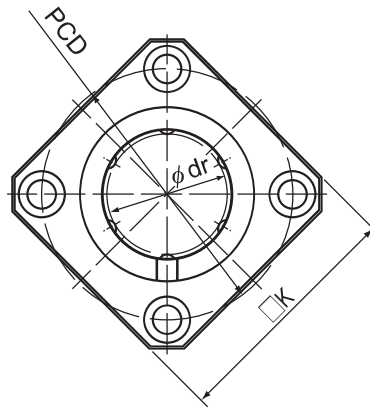
Model LMK-ML (Stainless Steel Type)



Model LMK-ML

Model No.	Ball rows	Main dimensions							
		Inscribed bore diameter		Outer diameter		Length		Flange diameter	
		dr	Tolerance	D	Tolerance	L	Tolerance	D ₁	Tolerance
LMK 6ML	4	6	0 -0.010	12	0	35	0 -0.3	28	0 -0.2
LMK 8ML	4	8		15	-0.013	45		32	
LMK 10ML	4	10		19	0	55		39	
LMK 12ML	4	12		21	-0.016	57		42	
LMK 13ML	4	13		23	0	61		43	
LMK 16ML	5	16	28	0	70	48			
LMK 20ML	5	20	32	0	80	54			
LMK 25ML	6	25	40	-0.019	112	0	62		
LMK 30ML	6	30	45	0	123	-0.4	74		

Note) Since this model contains a synthetic resin retainer, do not use it at temperature exceeding 80°C.
If requiring a type equipped with a seal, indicate it when placing an order.

(Example) LMK8ML UU

└────────── Seal attached on both ends of the nut

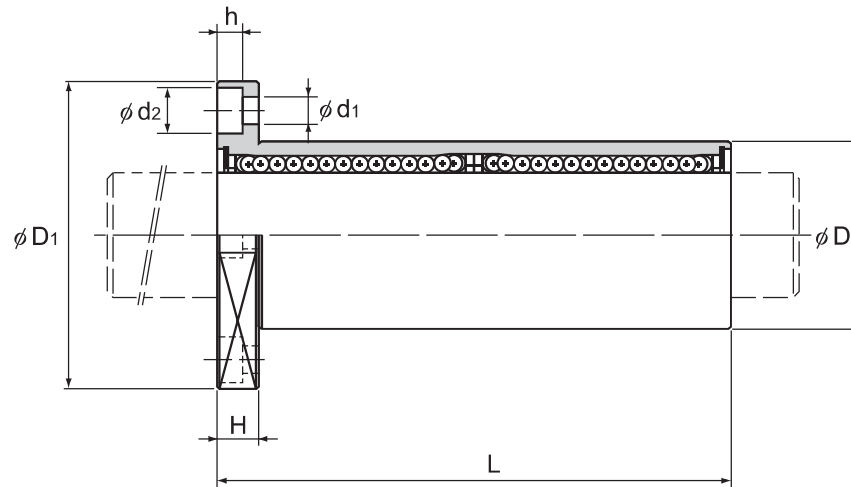

Unit: mm

	K	H	PCD	Mounting hole $d_1 \times d_2 \times h$	Flange perpendicularity μm	Eccentricity (max) μm	Radial clearance tolerance μm	Basic load rating		Mass g
								C N	C_0 N	
	22	5	20	$3.4 \times 6.5 \times 3.3$	15	15	-5	324	529	24
	25	5	24	$3.4 \times 6.5 \times 3.3$	15	15	-5	431	784	39
	30	6	29	$4.5 \times 8 \times 4.4$	15	15	-5	588	1100	68
	32	6	32	$4.5 \times 8 \times 4.4$	15	15	-5	657	1200	76
	34	6	33	$4.5 \times 8 \times 4.4$	15	15	-7	814	1570	100
	37	6	38	$4.5 \times 8 \times 4.4$	15	15	-7	1230	2350	176
	42	8	43	$5.5 \times 9.2 \times 5.4$	20	20	-9	1400	2750	210
	50	8	51	$5.5 \times 9.2 \times 5.4$	20	20	-9	1560	3140	466
	58	10	60	$6.6 \times 11 \times 6.5$	20	20	-9	2490	5490	569

Note) Since the nut and the balls use stainless steel, these models are highly resistant to corrosion and environment.
If an oil hole is required, this can be indicated by appending "OH" to the end of the model number.
For further information, contact THK.