



ASSURED QUALITY • COMPETITIVE PRICING

TECH FANATICS®

AUTOMOBILE GARAGE EQUIPMENT QUALITY ASSURED • COMPETITIVE PRICING



☎ 82736-82736

☎ 8539-880000

www.TECHFANATICS.IN

ABOUT US

At TECHFANATICS EQUIPMENT LIMITED, we take pride in being a leading manufacturer of garage equipment, providing innovative solutions for automotive workshops and enthusiasts worldwide. With a passion for precision engineering and a commitment to quality, we design and produce a wide range of cutting-edge equipment tailored to meet the diverse needs of modern garages. Large production capacity, large product line and good financial position and TQM is our strengths. Techfanatics is committed with ASSURED QUALITY AND COMPETITIVE PRICING.

Our team of skilled engineers and technicians bring decades of experience to every product we create, ensuring that each piece of equipment meets the highest standards of performance, reliability, and durability. From vehicle lifts and tire changers to diagnostic tools and wheel alignment systems, our comprehensive lineup of products is trusted by professionals and hobbyists alike for their accuracy, efficiency, and ease of use.

At TECHFANATICS, we understand the importance of staying ahead of the curve in an ever-evolving industry. That's why we continuously invest in research and development, striving to incorporate the latest technological advancements into our products. By staying at the forefront of innovation, we empower our customers to enhance their productivity, streamline their operations, and deliver exceptional service to their clients.

But our commitment to excellence doesn't end with our products. We also prioritize customer satisfaction, providing comprehensive support services to ensure that our clients get the most out of their TECHFANATICS equipment. Whether it's technical assistance, training programs, or maintenance services, our dedicated team is always ready to go the extra mile to meet our customers' needs.

OUR PRINCIPALS



SCAN ME !

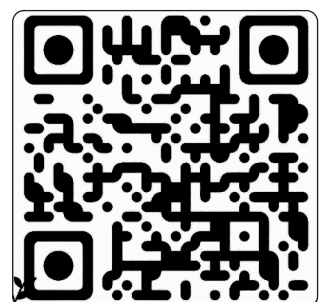

BUSINESS MODEL

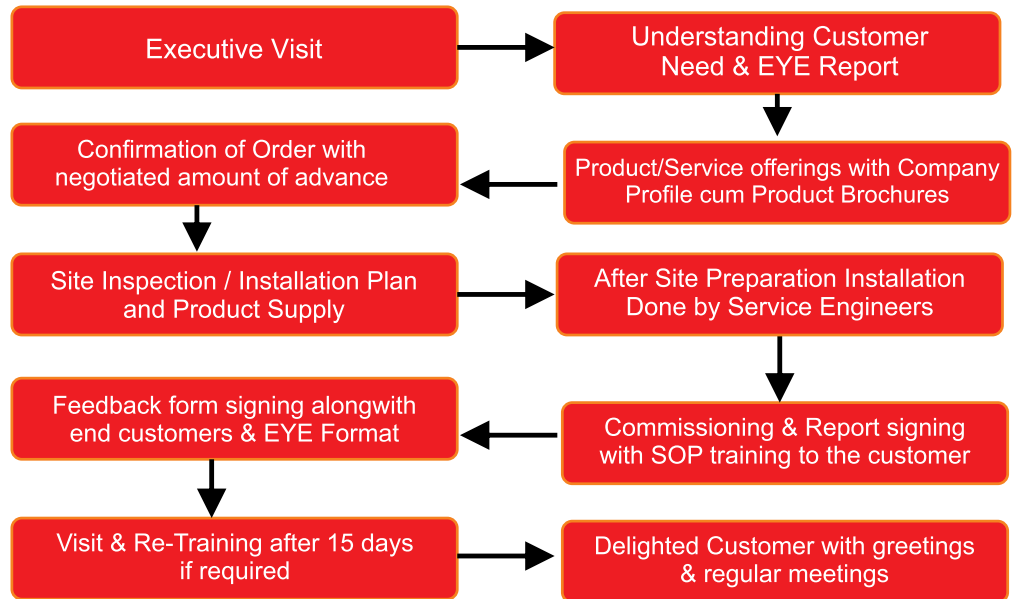

Why Techfanatics

Techfanatics have sustainable products and experienced & excellent R&D and designing team. Large production capacity, large product line and good financial position and TQM is our strengths. Techfanatics is committed with ASSURED QUALITY AND COMPETITIVE PRICING. Great after sales service and Big sales & service network all over India and many more countries.

Dedicated to safety and higher standards

Our client's safety is the most important thing. Techfanatics goes beyond the basic standards of services providers. We are way ahead than the prevailing market trends in operational services. We have set high standards and benchmarks for efficient and cost-effective services.

Diverse Techfanatics equipment and services

Techfanatics have full range for LCV, HCV and CARS segment like

- Tyre care equipment
- Lifting equipment
- Body shop equipment
- Car engine diagnostic
- Car workshop equipment
- Service station equipment
- Pollution control equipment
- Car air conditioning equipment
- Pneumatic tools and special tools for automobiles garage
- Some hot selling products are explained Like 3D Wheel alignment machine, Wheel balancer machine, Tyre changer, Nitrogen tyre inflator, Air compressor, Car washing lift, Two post lift, Alignment scissor lift, Portable lift, Car washer, Foam washer, Vacuum cleaner, Car scanner, Spot welder, Dent puller, Mig welder, Car Paint booth, Crash repair system etc.

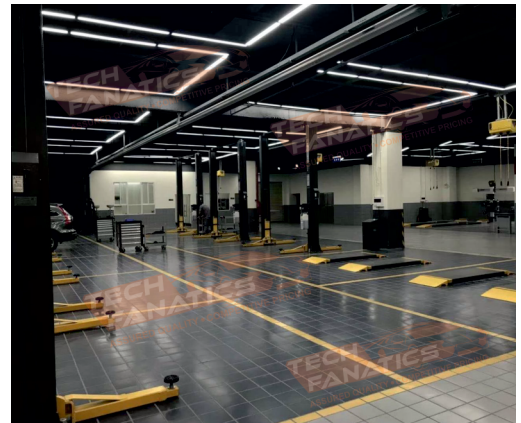

OUR PRODUCT

| | Page No. | | Page No. |
|--------------------------------|-------------|--------------------------------------|--------------|
| 1. Tyre Care Equipment | 1-8 | ASL - 5600 | |
| 1.1 3D Wheel Alignment Machine | | 2.5 Four Post Lift | |
| Blacktech X3D 9000 | | FPL - 3000 | |
| Ultrasonic V3D 7000 | | 3 Washing/Dry-clean Equipment | 11-15 |
| EL V3D 5000 | | 3.1 Car Washing Lift | |
| TFV - 6000 | | TF - 1100XL | |
| TFP - 8000 | | TF - 900XL | |
| 1.2 Wheel Balancer | | TF - 4600 | |
| WBV - 2600 | | 3.2 Car Washer | |
| WBV - 2000 | | TF - 500 | |
| WBD - 2200 | | TF - 700 | |
| WBD - 1440 | | TF - 800 | |
| 1.3 Tyre Changer | | 3.3 Vaccum Cleaner | |
| TF - 3800 | | TF - 25/1 | |
| TF - 3600 RFT | | TF - 30/1 | |
| TF - 2100S | | TF - 35/1 | |
| TF - 2000 5F | | TF - 45/1 | |
| TF - 2000 3F | | TF - 60/1 | |
| TF - 1800 | | TF - 70/2 | |
| TF - 1600 | | TF - 80/3 | |
| 1.4 Nitrogen Inflator | | 3.4 Dry Cleaning Machine | |
| TF - 3600 / TF - 3200 | | TF - 40 | |
| TF - 4000 | | TF - 20 | |
| 1.6 Air Compressor | | 3.5 Foam Washer | |
| TF - 1500 | | TF - 800 FW | |
| TF - 1000 | | 3.6 Steam Car Washer | |
| TF - 7500 | | TF - 500 SW-E | |
| TF - 500 | | TF - 200 SW-D | |
| TF - 300 | | TF - 200 SW-G | |
| 2. Lifting Equipment | 9-10 | 3.7 Automatic Car Washer | |
| 2.1 Two Post Lift | | TF - 4100 | |
| TPL - 1200 CF | | TF - 4000 | |
| TPL - 1100 BP | | 4 Body Shop Equipment | 16-18 |
| 2.2 Portable Scissor Lift | | 4.1 Car Body Repair System | |
| PSL - 900 / PSL-900S | | TF - 600 | |
| 2.3 Scissor Lift | | 4.1 Dent Pulling Machine | |
| TF - 1900 | | TF - 450 | |
| 2.4 Alignment Scissor Lift | | | |

| | Page No. | | Page No. |
|---|----------|--|----------|
| 4.2 Spot Welding Machine TF - 9700 | | 9 General Service Equipment-2 | 22 |
| 4.3 Mig Welding Machine TF - 850 | | 9.1 Tools Trolley TF - 4D | |
| 4.4 Plasma Cutter TF - 50 | | 9.2 Oil Collector TF - 450 OC | |
| 4.5 Infrared Dryer TF - 300 TF - 200 TF - 100 | | 9.3 Engine Crane TF - 2.0 | |
| 4.6 Paint Spray Booth TF - 1600 Spray Tech TF - 1200 Spray Tech | | 9.4 Transmission Jack TF - 1.5 | |
| 5 Crash Repair Equipment | 19 | 9.5 Hydraulic Press TF - 20 | |
| 5.1 Crash Repair System TF - 8000 | | 9.6 Tyre Vulcanizing Machine TF - 05 | |
| 6 General Service Equipment | 19-20 | 9.7 Rim Straightening Machine TF - 200R/TF - 140R | |
| 6.1 Injector Cleaner TF - 400 | | 9.8 Tyre Inflator TF - 2200 | |
| 6.2 Battery charger TF - 1224 | | 11 Commercial Vehicle Equipment | 23-25 |
| 6.3 Battery Booster TF - 1272 | | 11.1 Buses, Trucks & other Hcvs Wheel Alignment TF - 2000 CV | |
| 6.4 Spark Plug Cleaner TF - 700 | | 11.2 Wheel Balancer TF - 1400 CV | |
| 6.5 Head Light Beam Aligner TF - 130 | | 11.3 Tyre Changer TF - 500 CV TF - 400 CV TF - 300 CV | |
| 6.5 Engine Decarbonizing Machine TF - 500 ED | | 11.4 Pneumatic Gun For Truck 5000/NM - 3400/NM - 2400/NM | |
| 7 Air Conditioning Equipment | 21 | 11.5 Vehicle Test lane Machine TF - 5800 | |
| 7.1 Ac Recovery Machine TF - 1200 | | 11.6 Pneumatic Gun For Car 720/NM - 500/NM - 300/NM | |
| 7.2 Dust-free Sanding Machine TF-150 | | | |
| 8 Diagnostics Equipment | 21 | | |
| 8.1 Car Scanner X-431 PRO | | | |

3D WHEEL ALIGNMENT (BLACKTECH X3D-9000)

Main Features

- ❑ Windows operating system, newest Techfanatics software, include all functions from old software, with self-owned intellectual property.
- ❑ With black-box functions, all files can be saved for future analysis.
- ❑ Estimation Angle: Toe, Camber, Caster, S.A.I, push edge, Setback edge, Max turning point, wheel tread, Wheel base, Wheel moving radius.
- ❑ Quicker running for alignment with guiding menu, can read database within 3 minutes.
- ❑ 3D animated measurement, easy for training and operate.
- ❑ Manual enter height of vehicle.
- ❑ "MKS" measurement special for Benz.
- ❑ Measurement for Caster Trail.
- ❑ Measurement for Scrub Radius & SAI.
- ❑ Available for OEM vehicle database.
- ❑ Zero Toe adjustment for camber.
- ❑ Single Tie Rod Adjust.
- ❑ Voice brief for push-pull vehicle.
- ❑ Drag Link Adjust to ensure the steering wheel in the middle.



3D WHEEL ALIGNMENT (ULTRATRONIC V3D-7000)

Main Features

- ❑ Windows OS, operation system can be easily guided by "Next walk" heading.
- ❑ Outperform 20,000 database around the world and with a lifetime update organization.
- ❑ Repeat estimation exactness is ± 0.03 which be a world's driving level.
- ❑ Estimation Angle: Toe, Camber, Caster, S.A.I, push edge, Setback edge
One time RCP calibration is enough after the completion of equipment installation, easy operation, need no regular repeat this work.



3D WHEEL ALIGNMENT (ELV3D 5000)

Main Features

- ❑ 3D measuring technique : vehicle body foundations measuring technique, more accurate, more stable.
- ❑ Camera measuring technique : double camera unite with 4 target plate, initiate revolutionary measuring methods.
- ❑ Target plate : no electronic components, displacing the traditional electronic measuring head, cancelling the equipment failure caused by circuit.

Standard configuration:

- ❑ High precision digital camera x 2
- ❑ Camera Pillar x 1
- ❑ Target plate x 4
- ❑ 4-point wheel clamp x 4, Clamp bracket x 4
- ❑ Mechanical turntable x 2
- ❑ Steering wheel lock x 1 Brake pedal depressor x 1
- ❑ Computer x 1 (18 inch Liquid crystal TV) x 1 Inkjet printer x 1

| Measurement project | Accuracy | Measurement project |
|---------------------|-----------------------|---------------------|
| Display accuracy | 0.01° | |
| Camber | $\pm 0.02^\circ$ | $\pm 10^\circ$ |
| Caster | $\pm 0.06^\circ$ | $\pm 20^\circ$ |
| Kingpin Inclination | $\pm 0.06^\circ$ | $\pm 20^\circ$ |
| Toe-in & Toe-out | $\pm 0.02^\circ$ | $\pm 20^\circ$ |
| Set back | $\pm 0.02^\circ$ | $\pm 5^\circ$ |
| Thrust angle | $\pm 0.02^\circ$ | $\pm 5^\circ$ |
| Wheel Deviation | $\pm 0.08 \text{ ''}$ | |
| Axis Deviation | $\pm 0.08 \text{ ''}$ | |



3D WHEEL ALIGNMENT (TFV-6000)

Main Features

- ❑ Camera with cutting edge technology and most recent electronic parts.
- ❑ Both push-pull vehicle or turning target for estimation.
- ❑ Fiberglass break safe 8" target, interchangeable for each wheel.
- ❑ Beam Stature movable optional.
- ❑ Android framework programming.
- ❑ Solid 3D cameras catch targets consequently and show progressively.
- ❑ Voice brief for push-pull vehicle.
- ❑ Appropriate for passenger car.



PORTABLE 3D WHEEL ALIGNMENT (TFP-8000)

Main Features

- ❑ Android framework, tablet PC, cell phone and shrewd TV Optional.
- ❑ Versatile 5 pcs. of cameras for measurement and serviceable in outdoor.
- ❑ Break safe 8" target interchangeable for each wheel.
- ❑ WiFi correspondence among cameras, TV screen, tablet PC, cell phone, Keyboard and mouse.
- ❑ Appropriate for passenger car, small truck with under 6 meters in length of wheel base.
- ❑ Voice brief for push-pull vehicle.

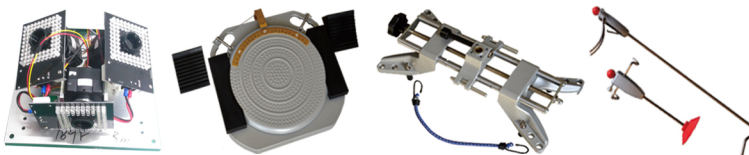

VIDEOGRAPHIC WHEEL BALANCER (WBV-2600)

Main Features

- ❑ Italian protected innovation
- ❑ 3D program: Automatically data input for Value B, D and L
- ❑ Static and dynamic adjusting program
- ❑ Multi ALU adjusting mode
- ❑ OPT program: enhance the coordinating of tyre and rim
- ❑ SPO program: to isolate the balance weight and hide behind the spokes in a non-visible position
- ❑ Store information for various wheel size
- ❑ Programming upgraded by USB port

Technical Specifications

| Model No. | WBV-2600 |
|---------------------|-----------------|
| Voltage | 220V |
| Rim Size | 10-30" |
| Tyre Width | 800mm |
| Clamping Capacity | 1.5-20" |
| Motor Power | 0.25kw |
| Rim Center Hole Die | Less than 145mm |
| Measuring Time | 7s |
| Balancing speed | 180rpm |
| Balancing accuracy | ±1g |



VIDEOGRAPHIC WHEEL BALANCER (WBV-2000)

■ Main Features

- ☒ Italian programming, simple, exactness, generally, vitality sparing, internal security.
- ☒ Low adjusting speed with 140rpm, accuracy $\pm 1-5g$, second time mounting on precision, less or equivalent to 5g.
- ☒ The utilization of LCD showcase and exceptional presentation card makes the display clear and distinctively.
- ☒ With standard USB interface. It is advantageous to redesign the more current programming
- ☒ Compare with the plastic measuring instrument, the aluminum programmed measuring instrument difficult to twist and estimation more precise.



DIGITAL WHEEL BALANCER (WBD-2200)

■ Main Features

- ☒ Accuracy 5gm, 1gm in fine mode.
- ☒ Self-Diagnostic Program.
- ☒ Self-Calibration Program.
- ☒ Programs for Rim / Alloy & Motorcycle Rims.
- ☒ Suitable for all Cars/SUVs

■ Technical Specifications

- ☒ Capacity: 65kg.
- ☒ Automatic Brakes.
- ☒ Balancing Speed: 200 rpm.
- ☒ Rim Diameter: 10" - 24".
- ☒ Rim Width: 1.5" - 20"



DIGITAL WHEEL BALANCER (WBD-1440)

■ Main Features

- ☒ A wheel balancer with self-guaranteed ensured advancement
- ☒ High accuracy fundamental shaft with strict heat treatment
- ☒ Outfitted with protection hood, forceps, full set of cones and calipers.
- ☒ Split and weight concealing functions.
- ☒ With DYN/STA and diverse adjusting mode
- ☒ With various creative data information modes



TYRE CHANGER (TF-3800)

Main Features

- ☑ Movable vertical shaft fix for different size wheels to correct position easily and quickly and also not damage the tyre bead.
- ☑ The max wheel size for this model could upto 30" and also suitable for car, van The standard accessory Includes the Inflation device and bead blaster.

Technical Specifications

| Model No. | TF-3800 |
|--------------------------|----------------|
| Voltage | 380V |
| Tyre Diameter | 1150mm |
| Clamping Capacity | 12"-24" |
| Motor Power | 1.1kw |
| Motor Rotation | 1400/2800r/min |
| Working oil Pressure | 8-12Mpa |
| Working air Pressure | 0.7-0.8Mpa |
| Bead Blast Pressure | 0.6-0.7Mpa |
| Turntable Speed | 6.8/13.6rpm |
| Bead Breaker force | 2500kg |
| Swing arm radius | 600mm |
| Weight | 400kg |
| Shaft longitudinal Shift | 285mm |



TYRE CHANGER (IRONCLAD TF 3600RFT)

Main Features

- ☑ **Unmatched Strength:** Built with a robust design to handle heavy-duty tasks and endure rigorous use in busy environments.
- ☑ **Versatile Range:** Capable of accommodating a wide range of rim sizes, making it suitable for various types of vehicles, including high-end models.
- ☑ **Powerful Performance:** Equipped with a high-performance motor that ensures efficient and reliable operation, crucial for fast tyre changes.
- ☑ **Ease of Use:** it makes the process of changing run-flat tires more efficient, especially when dealing with high-performance or heavy-duty vehicles.
- ☑ **Improved Tire Handling:** Run-flat tires are typically stiffer and more rigid than regular tires. The additional RFT arms help in handling these tires without damaging them or the wheel.
- ☑ **Solid Construction:** Made with durable materials, including an aluminum alloy bead breaking cylinder, ensuring long-lasting performance.
- ☑ **Advanced Technology:** Incorporates modern components such as dual capacitors and high-rated RF switches for enhanced functionality and reliability.
- ☑ **Luxury Ready:** Suitable for use in luxury workshops, with the capability to handle premium tyres and meet the high standards of sophisticated vehicles.

Technical Specifications

| Model No. | IRONCLAD TF 3600RFT |
|---------------------------|---|
| Rim Clamping From Inside | 11"-24" |
| Rim Clamping From Outside | 10"-23" |
| Max. Rim Diameter | 1040mm/1140mm/1260mm (Optional) |
| Max. Rim Width | 355mm/365mm/410mm (Optional) |
| Power | 1.5 Hp, Dual Capacitor |
| Rf Switch | 40 Amp |
| Working Pressure | 8-10 Bar |
| Bead Breaking Force | 2800 Kg |
| Power Supply | 220v, Single Phase , 50/60hz |
| Turntable Speed | 7.5 Rpm |
| Turntable Size | 25-26 Inches |
| Inflation Gauge | Standard (optional Quick Inflation Gauge With Additional Pedal) |
| Packing Style | Wooden Box |
| G. Weight (approx.) | 330 Kg |
| Noise | <70db |



TYRE CHANGER (TURBO-X TF 2100S)

■ Main Features

- ❑ **Ergonomically designed:** Controls with three pedals & one more additional pedal placed for optimal operator convenience.
- ❑ **High-Performance Motor:** Equipped with a 1.5 Hp motor, providing reliable and efficient operation.
- ❑ **Robust Bead Breaker:** The bead breaking cylinder delivers a powerful force of 2800 kg, ensuring quick and effective bead breaking.
- ❑ **Versatile Rim Clamping:** Accommodates a wide range of rim sizes from 10 to 24 inches, making it suitable for various types of vehicles.
- ❑ **Durable Construction:** Built with high-quality materials for long-lasting performance and durability in high-demand environments.
- ❑ **Inflation Pedal:** Facilitates easy and accurate tyre inflation directly from the machine, integrating the inflation process into the tyre changing workflow.
- ❑ **Precision and Control:** Features a dual capacitor for improved stability and precision during operation.
- ❑ **Optimal Working Pressure:** Operates efficiently within a pressure range of 8 to 10 bar, ensuring consistent performance.
- ❑ **Compact Design:** With a gross weight of approximately 240-250 kg, it is designed for stability while maintaining a manageable footprint.
- ❑ **The Techfanatics TurboX Tyre Changer Machine:** combines advanced technology with robust construction to deliver superior performance and reliability for automotive service professionals.



■ Technical Specifications

| Model No. | TURBO-X TF 2100S |
|---------------------------|---|
| Rim Clamping From Inside | 11"-24" |
| Rim Clamping From Outside | 10"-23" |
| Max. Rim Diameter | 1040mm/1140mm/1260mm (opt) |
| Max. Rim Width | 355mm/365mm/410mm (opt) |
| Power | 1.5 Hp, Dual Capacitor |
| RF Switch | 40 Amp |
| Working Pressure | 8-10 Bar |
| Bead Breaking Force | 2800 Kg |
| Power Supply | 220v, Single Phase , 50/60hz |
| Turntable Speed | 7.5 Rpm |
| Turntable Size | 25-26 Inches |
| Inflation Gauge | Standard (optional Quick Inflation Gauge With Additional Pedal) |
| Packing Style | Wooden Box |
| G. Weight (approx.) | 240-250 Kg |
| Noise | <70db |

TYRE CHANGER (POWER PRO TF 2000 5F)

■ Main Features

- ❑ Suitable for car and LCV tyres.
- ❑ Comes with bird head and jaw plastic protectors.
- ❑ Mini helper arm or Mini Pressing Tool (Optional) in all machine
- ❑ Comes with a servicing unit that includes a filter, separator, and Lubricator.
- ❑ Features a flexible mounting arm for space-efficient installation near walls.
- ❑ Comes with Square Column (Round Column is optional)
- ❑ **Powerful Motor:** 1.5 Hp Motor with dual capacitors for reliable and powerful operation.
- ❑ **Advanced Clamping:** Rim clamping size of 10-24 inches for versatility.
- ❑ **Digital Accuracy:** Equipped with a digital gauge for precise measurements.
- ❑ **High Working Pressure:** Operates at 8-10 bar for optimal performance.
- ❑ **Strong Bead Breaking:** Advanced bead breaking cylinder provides a force of 2800kg.
- ❑ **Easy Handling:** Designed for professional use with user-friendly controls.
- ❑ **Heavy Weight Stability:** Gross weight of approximately 205kg for stable and robust operation.
- ❑ **Ergonomically designed:** Controls with five pedals placed for optimal operator convenience.
- ❑ **High Durability:** Built with heavy-duty materials for long-lasting performance.
- ❑ **Precision Engineering:** Ensures accurate and efficient tyre changing.



■ Technical Specifications

| Model No. | POWER PRO TF 2000 5F |
|---------------------------|-------------------------------|
| Rim Clamping From Inside | 11"-24" |
| Rim Clamping From Outside | 10"-23" |
| Max. Rim Diameter | 1040mm |
| Max. Rim Width | 355mm/365mm/410mm |
| Power | 1.5 Hp, Dual Capacitor |
| Rf Switch | 40 Amp |
| Working Pressure | 8-10 Bar |
| Bead Breaking Force | 2800 Kg |
| Bead Breaking Opening | 355mm/410mm |
| Power Supply | 220v, Single Phase , 50/60 Hz |
| Turntable Speed | 7.5 Rpm |
| Turntable Size | 26 Inches |
| Inflation Gauge | Digital |
| Packing Style | Wooden Box |
| G. Weight (approx.) | 205 Kg |

TYRE CHANGER (TORQUE MASTER TF 2000 3F)

■ Main Features

- ☒ Suitable for car and LCV tyres.
- ☒ Comes with bird head and jaw plastic protectors. Mini helper arm or Mini Pressing Tool (Optional)
- ☒ A self-aligning four-jaw chuck ensures precise rim clamping.
- ☒ Comes with a servicing unit that includes a filter, separator, and Lubricator.
- ☒ Features a flexible mounting arm for space-efficient installation near walls.
- ☒ Comes with Square Column (Round Column is optional)
- ☒ **Powerful Motor:** 1.5 Hp Motor with dual capacitors for reliable and powerful operation.
- ☒ **Advanced Clamping:** Rim clamping size of 10-24 inches for versatility.
- ☒ **Digital Accuracy:** Equipped with a digital gauge for precise measurements.
- ☒ **High Working Pressure:** Operates at 8-10 bar for optimal performance.
- ☒ **Strong Bead Breaking:** Advanced bead breaking cylinder provides a force of 2800kg.
- ☒ **Easy Handling:** Designed for professional use with user-friendly controls.
- ☒ **Heavy Weight Stability:** Gross weight of approximately 205kg for stable and robust operation.
- ☒ **Ergonomically Designed:** Controls with Three pedals placed for optimal operator convenience.
- ☒ **High Durability:** Built with heavy-duty materials for long-lasting performance.
- ☒ **Precision Engineering:** Ensures accurate and efficient tyre changing.



■ Technical Specifications

| Model No. | TORQUE MASTER TF 2000 3F |
|---------------------------|-------------------------------|
| Rim Clamping From Inside | 13"-24" |
| Rim Clamping From Outside | 12"-23" |
| Max. Rim Diameter | 1040mm |
| Max. Rim Width | 355mm/365mm/410mm |
| Power | 1.5 Hp, Dual Capacitor |
| Rf Switch | 40 Amp |
| Working Pressure | 8-10 Bar |
| Bead Breaking Force | 2800 Kg |
| Bead Breaking Opening | 365mm/410mm |
| Power Supply | 220v, Single Phase , 50/60 Hz |
| Turntable Speed | 7.5 Rpm |
| Turntable Size | 26 Inches |
| Inflation Gauge | Digital |
| Packing Style | Wooden Box |
| G. Weight (approx.) | 205 Kg |

TYRE CHANGER (TITAN TF 1800)

Main Features

- ☑ Suitable for car and LCV tyres.
- ☑ Comes with bird head and jaw plastic protectors. Mini helper arm or Mini Pressing Tool (Optional)
- ☑ A self-aligning four-jaw chuck ensures precise rim clamping.
- ☑ Comes with a servicing unit that includes a filter, separator, and Lubricator.
- ☑ Features a flexible mounting arm for space-efficient installation near walls.
- ☑ Comes with Square Column (Round Column is optional)
- ☑ **Motor:** 1 Hp Motor for reliable operation.
- ☑ **Versatile Capability:** Accommodates a variety of tyre sizes 12-24 inches, making it adaptable for different types of vehicles and tyres.
- ☑ **Analogue Gauge:** Equipped with a Analogue gauge for measurements.
- ☑ **High Working Pressure:** Operates at 8-10 bar for optimal performance.
- ☑ **Bead Breaking:** Bead breaking cylinder provides a force of 2500kg.
- ☑ **Easy Handling:** Designed for professional use with user-friendly controls.
- ☑ **Heavy Weight Stability:** Gross weight of approximately 190kg for stable operation.
- ☑ **Ergonomically designed:** Controls with five pedals (3 Pedals optional)placed for optimal operator convenience.
- ☑ **High Durability:** Built with heavy-duty materials for long-lasting performance.
- ☑ **Precision Engineering:** Ensures accurate and efficient tyre changing.

Technical Specifications

| Model No. | TITAN TF 1800S |
|---------------------------|-------------------------------|
| Rim Clamping From Inside | 13"-24" |
| Rim Clamping From Outside | 12"-23" |
| Max. Rim Diameter | 1000mm |
| Max. Rim Width | 310mm/355mm |
| Power | 1 HP |
| Rf Switch | 25 Amp |
| Working Pressure | 8-10 Bar |
| Bead Breaking Force | 2500 kg |
| Bead Breaking Opening | 310mm/355mm |
| Power Supply | 220V, single phase , 50/60 hz |
| Turntable Speed | 6.5 rpm |
| Turntable Size | 24 inches |
| Inflation Gauge | Analog |
| Feet Paddle Format | 5 (3 Paddles Optional) |
| G. Weight (approx.) | 190 kg |



TYRE CHANGER (TF-1600)

Technical Specifications

| Model No. | TITAN TF 1800S |
|---------------------------|-------------------------------|
| Rim Clamping From Inside | 13"-22" |
| Rim Clamping From Outside | 12"-21" |
| Max. Rim Diameter | 980mm |
| Max. Rim Width | 305mm |
| Power | 1 HP |
| Rf Switch | 16Amp |
| Working Pressure | 8-10 Bar |
| Bead Breaking Force | 2500 kg |
| Bead Breaking Opening | 310mm/355mm |
| Power Supply | 220V, single phase , 50/60 hz |
| Turntable Speed | 6.5 rpm |
| Turntable Size | 22 inches |
| Inflation Gauge | Analog |
| Feet Paddle Format | 5 (3 Paddles Optional) |
| G. Weight (approx.) | 182 kg |



NITROGEN TYRE INFLATOR (TF-3200 / TF-3600)

Main Features

We are the prominent Manufacturer, Exporter and Supplier of exceptionally utilitarian Nitrogen Tyre Inflator. Applicable for vehicles like bikes, autos, vans, small scale transports and light trucks.

Technical Specifications

- ☑ Power Supply: 230V/50~60Hz
- ☑ Power: 200w
- ☑ Nitrogen Purity: 95-99.5%
- ☑ Compressed Air Pressure Required : 8-12 bar
- ☑ Nitrogen Output: 66L/min@ 8-12 bar



NITROGEN TYRE INFLATOR (TF-4000)

Main Features

We are the prominent Manufacturer, Exporter and Supplier of exceptionally utilitarian Nitrogen Tyre Inflator. Applicable for vehicles like Bus, Truck & HCV. The Purity of the nitrogen is 95-99%. We make accessible Nitrogen Tyre Generator in mass and at market leading rates.

| Model No. | | TF-4000 | |
|---|-----------------------|------------------------|-----------------|
| 1. Recomm. Input Pressure | 12 kg/cm ² | 6. Nitrogen Output | 150L/min@12 Bar |
| 2. Purity of Nitrogen | 95-99% | 7. Weight | 210 Kg |
| 3. Storage Tank Size | 250 Ltrs | 8. Power Supply | 230V/50 Hz |
| 4. N ₂ Generating Capacity | 8000 lph | 9. Vehicle Application | Bus, Truck, HCV |
| 5. Compressed Air Pressure Required <12 Bar | | 10. Power | 200-400W |



AIR COMPRESSOR

Product Description

Techfanatics offering best quality, More efficient and reliable Air Compressor.

Main Features

- ☑ Double stage air compressor
- ☑ Highly efficient with durable metal Sheet.

Technical Specifications

| Model No. | TF-300 | TF-500 | TF-7500 | TF-1000 | TF-1500 | TF-1500 |
|--|--|--------|---------|---------|---------|---------|
| Power (HP) | 3 | 5 | 7.5 | 10 | 15 | 15 |
| Compressor (RPM) | 975 | 710 | 975 | 710 | 943 | 943 |
| Tank capacity (ltrs.) | 160 & 220 | 250 | 250 | 420 | 500 | 500 |
| Working pressure (kg/cm ²) | 12 | 12 | 12 | 12 | 12 | 19 |
| Free Air delivery (LPM) | 263 | 390 | 536 | 781 | 1036 | 1008 |
| No. of cylinders | 2 | 2 | 2 | 3 | 3 | 3 |
| Power supply | 220V AC, 1 Phase or 380-415V AC, 3 Phase, 50Hz | | | | | |





TWO POST LIFT

Technical Specifications

| Model No. | TPL-1100BP |
|---------------------------------|----------------------|
| Lifting capacity | 4 Ton |
| Overall height | 2844 mm |
| Bay width | 3419 mm |
| Inside column | 2799 mm |
| Load distribution (front: Rear) | 2:3 |
| Lifting time | <45 seconds |
| Drive through clearance | 2579 mm |
| Maximum lifting height | 1800 mm |
| Minimum height | 110 mm |
| Lifting arm adjustments | Front Rear |
| Minimum length | 700 mm 927 mm |
| Maximum length | 900 mm 1317 mm |
| Power supply | 1 Phase 3Phase, 50Hz |
| Power | 3.0 HP |



TWO POST LIFT

Technical Specifications

| Model No. | TPL-1200CF |
|---------------------------------|-----------------------|
| Lifting capacity | 4 Ton |
| Overall height | 3620 mm |
| Bay width | 3500 mm |
| Inside column | 2886 mm |
| Load distribution (front: Rear) | 2:3 |
| Lifting time | <45 seconds |
| Drive through clearance | 2640 mm |
| Maximum lifting height | 1800 mm |
| Minimum height | 110 mm |
| Lifting arm adjustments | Front Rear |
| Minimum length | 712 mm 992 mm |
| Maximum length | 1051 mm 1462 mm |
| Power supply | 1 Phase, 3Phase, 50Hz |
| Power | 3.0 HP |



PORTABLE SCISSOR LIFT

Technical Specifications

| Model No. | PSL-900/PSL-900S |
|---------------|--------------------|
| Capacity | 3000 kg / 4000kg |
| Max. Height | 1463 mm/1524mm |
| Min. Height | 115 mm |
| Power Supply | 220V /380V |
| Oil Supply | 6-8 Ltr./cm3 |
| Lifting Time | 30s |
| Oil Pressure | 18 -20 Mpa |
| Power | 3.0 HP |
| Hydraulic Oil | 46#wear-resistance |



SCISSOR LIFT

Technical Specifications

| Model No. | TF-1900 |
|-----------------|---------------------------------|
| Capacity | 3000kg/3500kg |
| Rise/ Drop time | 60/45 Seconds |
| Lift height | 2130mm(traver route) |
| Platform length | 1650mm-2050mm |
| Platform width | 550mm |
| Min height | 330mm |
| Power supply | 380V/220V |
| Motor power | 2.2kw |
| Hydraulic oil | 46#wear-resistant hydraulic oil |

ALIGNMENT SCISSOR LIFT (ASL-5600)

Technical Specifications

| Model No. | ASL-5600 | |
|-----------------------------|---------------------------|------------|
| Drive Through | Electrical & Hydraulic | |
| Maximum Capacity | 3500kg/4000 kg | 7716 lbs |
| Overall Length | 4480 mm | 176 inches |
| Primary Runway Length | 4000 mm | 157 inches |
| Second Runway Length | 1400 mm | 55 inches |
| Overall Width | 2160 mm | 85 inches |
| Width Between Runway | 920 mm | 36 inches |
| Primary Scissor Lift Height | 1862 mm | 73 inches |
| Second Scissor Lift Height | 456 mm | 18 inches |
| Runway Initial Height | 330 mm | 13 inches |
| Power Requirements | AC 400 or 220V± 5% / 50Hz | |

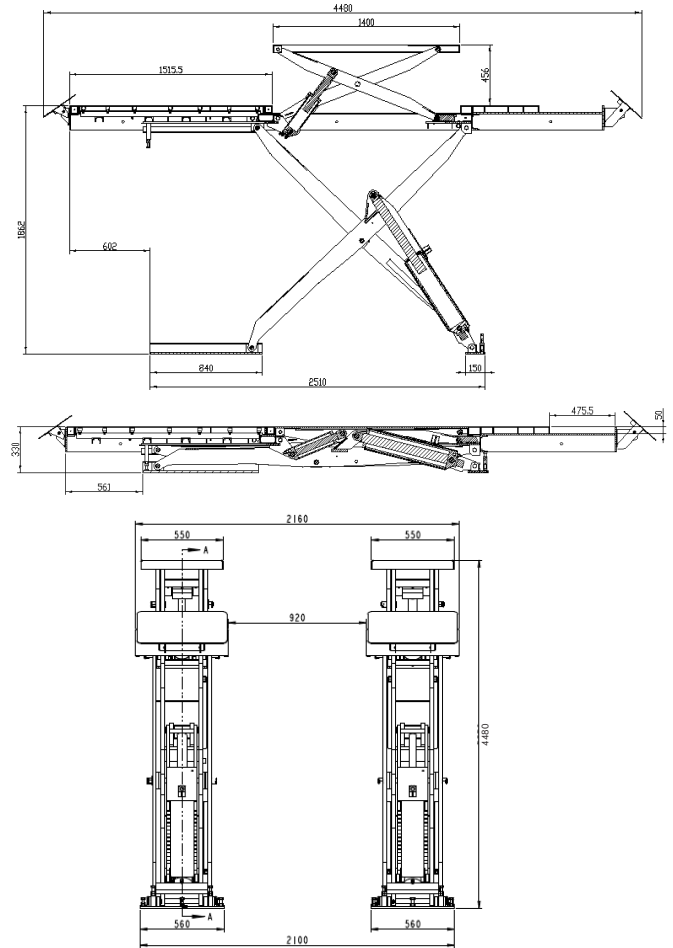

Figure 2-Lift Dimensions

FOUR POST LIFT (FPL-3000)

Main Features

- ❑ Enormous Pulley for steel rope
- ❑ Height limit switch
- ❑ Safety valve for anti-explosion of hydraulic system
- ❑ Outfitted with principle protection and rope break protection on every column
- ❑ Manual Lock Release (Optional Pneumatic Lock Release)

Technical Specifications

| Model No. | FPL-3000 |
|------------------|-------------------------------------|
| Lifting Capacity | 3500 KG / 4000 KG |
| Lifting Height | 1700 mm(67 inches) |
| Platform Height | 175mm(6.9 inches) |
| Platform Length | 4250 mm (167 inches) |
| Power of Motor | 220V 1PH 50/60Hz / 380V 3PH 50/60Hz |
| Power Supply | 2.2kw |

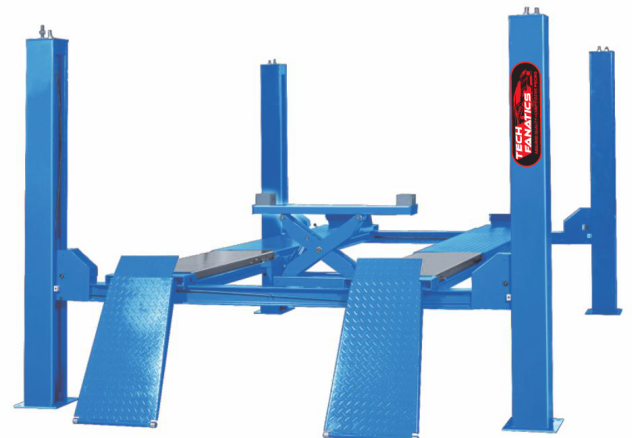

HYDRAULIC CAR WASHING LIFT (TF-1100XL)

Product Description

Attributable to our rich industry experience, we enjoy assembling and providing an extraordinary Car Washing Lift. Structured and fabricated in consistence with universal measures

Main Features

- ☒ Plungers are of high grade mild steel manufactured to close tolerance with double hard chrome plating for high wear resistance and good finish.
- ☒ Outer cylinder coated with Fiber Reinforced Plastic protecting it against corrosion (optional)
- ☒ Uniquely designed wiper rings prevent entry of water and dust into the Hoist cylinder
- ☒ Gland rings used in the plungers are designed for enhanced performance

Technical Specifications

- ☒ Capacity (Ton): 4
- ☒ No. of Posts: 1
- ☒ Plunger Diameter (mm) : 272
- ☒ Operating Pressure (Kg/cm²): 9 to 12
- ☒ Lifting Height (mm): 1520
- ☒ Ramp Length front (mm): 3962
- ☒ Ramp Width (mm): 792
- ☒ Oil fill Capacity (Ltrs): 180



HYDRAULIC SPIDER ARM WASHING LIFT (TF-900XL)

Technical Specifications

- ☒ 5-10 Bar pressure air as lift power,
- ☒ lift weight capacity 4T
- ☒ max 1.5M lift height
- ☒ High quality cylinder
- ☒ strong material, stainless.
- ☒ 360 degree turn over.



BUS WASHING LIFT (TF-4600)

Main Features

- ☒ Plungers are of high grade mild steel manufactured to close tolerance with double hard chrome plating for high wear resistance and good finish.
- ☒ Outer cylinder coated with Fiber Reinforced Plastic protecting it against corrosion (optional)
- ☒ Uniquely designed wiper rings prevent entry of water and dust into the Hoist cylinder

Technical Specifications

- ☒ Type Double Cylinder Hydraulic Lift
- ☒ Material Used : Mild Steel
- ☒ Maximum Load(tons) : 4-8
- ☒ Maximum Rise(mm) : 1520
- ☒ Number of Guide Posts : 2 Post



CAR WASHER

Product Description

We have set up our Company in the world market among the well-eminent producers and providers of Heavy Obligation Two/Three Cylinder Truck and Car Washer. The washer set forward by us is precisely made by our deft experts in consistence with the set quality norms, we have additionally imported itallian vehicle washer and steam vehicle washer for Indian market. In Indian Car Washer Double Gun Is Optional. In Imported car washer same specifications have wall mounted.

Technical Specifications

| Model No. | TF-500 | TF-700 | TF-800 |
|--------------------|--------|----------|--------|
| R.P.M. of Motor | 1440 | 1440 | 1440 |
| Max. Pressure Psi | 1300 | 1750 | 2100 |
| Flow Rate | 35 LPM | 12.6 LPM | 13 LPM |
| Motor Recommended | 2.2Kw | 2.2Kw | 3Kw |
| High pressure hose | 10 m | 10 m | 10 m |

TF-800



TF-500



TF-700



WALL MOUNTED

VACCUM CLEANER

Product Description

Dry, wet & blowing multi-functional use, which makes the cleaning more effective Commercial use with high-power and strong suction, 25L, 35L, 45L, 60L, 70L, 80L, dust cup capacity, 5m operation radius, Adopt imported stain steel, its firm and durable High effective motor, which meets the EU standard

Technical Specifications

| Model No. | TF-25 | TF-35 | TF-45 | TF-60 | TF-70 | TF-80 |
|-----------------|----------|----------|----------|----------|----------|----------|
| Motor | Single | Single | Single | Single | Double | Tripple |
| Motor Power | 1200W | 1500W | 1800W | 1800W | 3600W | 5400W |
| Capacity | 25Ltr. | 35Ltr. | 45Ltr. | 60Ltr. | 70Ltr. | 80Ltr. |
| Related Voltage | 220~240V | 220~240V | 220~240V | 220~240V | 220~240V | 220~240V |
| Air Flow | 53L/S | 53L/S | 53L/S | 53L/S | 106L/S | 159L/S |
| Function | Wet/Dry | Wet/Dry | Wet/Dry | Wet/Dry | Wet/Dry | Wet/Dry |
| Tank Diameter | 320mm | 340mm | 340mm | 380mm | 440mm | 440mm |
| Hose Diameter | 36mm | 38mm | 40mm | 40mm | 40mm | 40mm |
| Cooling System | Recycle | Recycle | Recycle | Recycle | Recycle | Recycle |



CAR DRY-CLEANING MACHINE

Product Description

Techfanatics offering car dry cleaning and carpet cleaning machines with assured quality & competitive pricing this is very popular product in market.

Technical Specifications

| Model No. | TF-20 & TF-40 |
|---------------------|------------------------------------|
| Function | Wet And Dry |
| Power (W) | 1034 |
| Voltage (V) | 220 |
| Capacity | 20L, 40L |
| Vacuum Suction | 230mbar |
| Air Flow Rate | 53L/S |
| Application | Car Dry cleaning & carpet cleaning |
| Power of water pump | 34W |



FOAM WASHER (TF-800FW)

Product Description

Consistent pneumatic foam sprayers need a perpetual connection to an air compressor. In this way air mixes with the chemical product producing a soft and voluminous foam that persists on surfaces with a little chemical product, It is possible to treat wider areas or tough dirt.



STEAM CAR WASHER (TF-500 SW-E)

Product Description

Car wash using just a bit of water. Environmental friendly system, Wash & Wax, Bacteria killer. It has powerful steam, durable & easy operate machine with new technology, top quality, industrial standard safety.

Applications: Mobile Car Wash, Auto Detailing, Buses, Trucks & Vans cleaning, Commercial Kitchen cleaning, Boat & Air craft cleaning & Medical Industry.



Technical Specifications

| MODEL NO. | TF-200 SW-D/SW-G | TF-500 SW |
|----------------------|-------------------------|-------------------------|
| Dimension | W-50 x L-115 x H-78(cm) | W-48 x L-70 x H-105(cm) |
| Hose Length | 10m | 10m |
| Gross Weight | 80 kg | 70 kg |
| Water tank capacity | 18 liter | 18 liter |
| Wax tank capacity | 1 liter | 1 liter |
| Electric Power rate | 220~240V (50/60hz) | 220~240V (50/60hz) |
| Electric Power | 4kw / 6kw | 4kw / 6kw / 9kw |
| Fuel/Gas consumption | 20g/min | No Requirement |
| Steam Pressure | 8~10 Bar | 8~10 Bar |
| Steam temperature | 160~170 C | 174~180 C |
| Preheating time | 2~5 minute | 16~17 minute |
| Water consumption | 9ltr-12ltr/hr | 9ltr-12ltr/hr |
| No of Gun | 1 | 2 (9kw) |

STEAM CAR WASHER (TF-200 SW)



AUTOMATIC CAR WASHER (TF-4000)

Product Description

Techfanatics provide array of Car Wash Machine is considered as the incredible strategy utilized for giving simple and productive vehicle washing occupations. Helpful to work and keep up, these machines are brilliantly assembled by utilizing quality assured components and material. Known for its dependable and solid execution, our Car Wash Machine is available to our customers all things considered sensible rates.

Main Features

- ☑ Compact design
- ☑ Long working life
- ☑ Optimum operational efficiency

Car Wash Works on five stage

- ☑ Stage1 High pressure Water Jet on the Car Body.
- ☑ Stage 2 Brush Scrubbing / spray of detergent
- ☑ Stage 3 Scrubbing of detergent by foam pads Brush
- ☑ Stage 4 High pressure water Jet to wash away the soap
- ☑ Stage 5 High pressure air for drying (Optional)

Advantage

- Low water consumption
- Less time per vehicle
- Very easy to operate
- Cost effective



TOUCHLESS CAR WASHER (TF-4100)

Tech 360° magic wash

Product Description

The most up to date Techfanatics in-straight programmed vehicle wash raises the standard for touchless vehicle wash Equipment. With Revenue Enhancement and Total Cost of Ownership upgrades being the fundamental center, this vehicle wash system conveys the business' best Return on Investment. Tech 360 Technology empowers the vehicle wash system to be receptive to the dynamic conditions in the wash bay

Tech 360 innovation empowers Techfanatics to be profoundly receptive to dynamic conditions in the wash bay, limiting vacation and enhancing the wash procedure, bringing about higher consumer loyalty and rehash business.

Main Features

Tech 360 Technology

Techfanatics curve Control System takes into account speedier through put and makes client certainty and solace through the whole wash process. The curve can turn 360 degrees while at the same time moving around the vehicle. Three pivot movements give adjusted corner profiling to deliver predictable inclusion by keeping the nozzles constantly centered around the vehicle. Curve control makes each second profitable in the wash process. The Tech 360 curve Control additionally works around the total vehicle edge. checking and acclimating to conditions to keep specialist collaboration low.

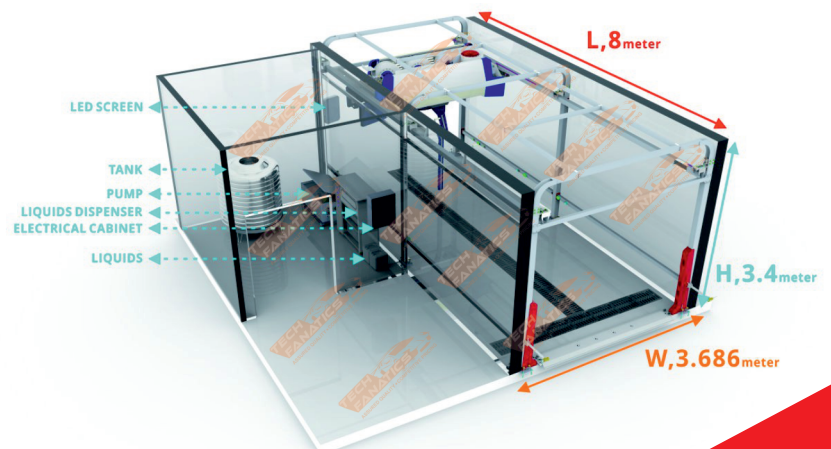

■ **Advantages**

- ☑ Intelligent completely programmed working systems, 24 hours
- ☑ Self-service card reader payment system (Optional)
- ☑ Tech 360 technology for quick cleaning each side of vehicles
- ☑ Intelligent liquid dispenser for apply presoaks, tri-colors foam, shampoo, wax.
- ☑ Inventive suspension framework with easy rails.
- ☑ Unique inserted quick dry/blower system (Optional)
- ☑ Digital voice security caution system (Optional)
- ☑ Faulty self-checking system (Optional)
- ☑ Programmed impact evasion.
- ☑ One key enemy of solidified system (Optional)
- ☑ E-Chain Utility Routing.



■ **Product Design**

100Bar high pressure chassis(multiple-class pressure) and paint flush.
 Tech 360 rotary arm, flush paint 360° and apply different liquids.
 High precision(0.1L) dispenser, just takes 20~50ml fluids utilization for every vehicle.
 Tri-color thick foam cleans soil completely (Optional)
 Softer water accompanies precious wax covering.
 saving 50% water and 60% power cost.
Washing Process(Adjustable/customizable)

- ☑ Begin
- ☑ Wheel brushes (Optional)
- ☑ Underbody (Optional)
- ☑ Presoaks
- ☑ High pressure flush
- ☑ foam spray
- ☑ Wax downpour
- ☑ Coordinated dryers/blower (Optional)

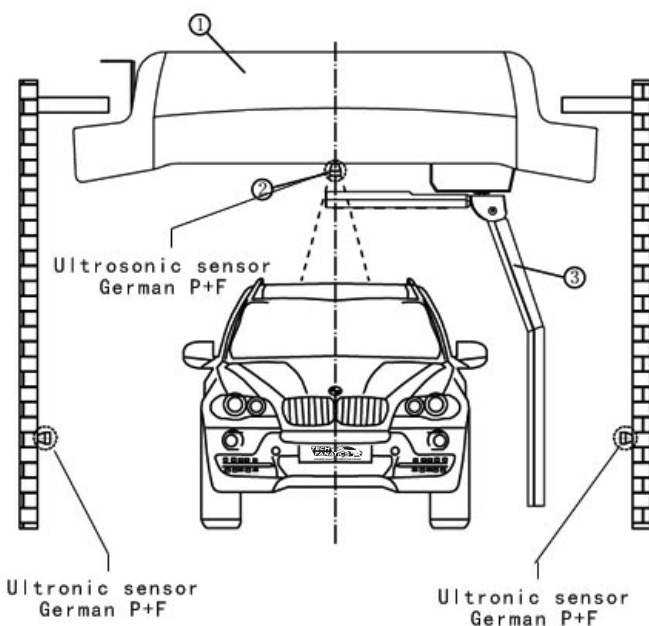

CAR BODY REPAIR SYSTEM (TF-600)

Main Features

Automatic Induction Welding Technology, Microsoft processor control LCD text display, welding time accurate to 0.01 s, welding power 20-99% stepless adjustment 10 operating modes, automatic memory of the last operating parameters of the welding temperature reached a critical, the welding automatically into the cooling state.

| MODEL NO. | TF-600 |
|----------------|-------------------------------|
| Input voltage | 220V/ 380V ; 50/60Hz |
| Input power | 21KVA |
| Input current | 60A/32A |
| MAX | 5600A |
| Output voltage | 1-9V |
| Operation way | Electronic timer continuously |
| Welding time | Auto |
| Gear | Stepless |



DENT PULLING MACHINE (TF-450)

Product Description

Chip control system advances the welding parameters. Because of the reception of cutting edge computerized control innovation and adaptation structure, you should simply choose the welding current comparing to the workpiece thickness to accomplish the best weld quality. Welding gun testing capacity to assess the utilizing status of welder all the more totally.

Various of welding procedures are available as optional such as shrinking, washer, direct-pulling, spot welding, flatten-ing, waveform wire, stud welding, OT washer, triangle washer, etc .

Technical Specifications

| MODEL NO. | TF-450 |
|----------------|-------------------------------|
| Input voltage | 220V/ 380V ;50/60Hz |
| Input power | 21KVA |
| Input current | 54A/32A/16A |
| MAX | 3800A |
| Output voltage | 1-7V |
| Operation way | Electronic timer continuously |
| Welding time | Auto |

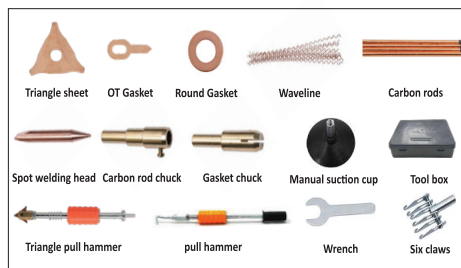

SPOT WELDING MACHINE (TF-9700)

Main Features

The chip control system streamlines the welding parameters. Utilizing progressed Digital control innovation and easy to understand structure, you should simply choose the welding current comparing to the work piece thickness to accomplish the best welding outcomes.

Assortment of welding systems are Available, for example, shrinking, washer, direct-pulling, spot welding, flattening, waveform wire, stud welding, OT washer and triangle washer, Overheating assurance, Complete with air filter and pressure controller, Digital realistic display, preset weld programs, Optional with pneumatic vaccum couple, Automatic mains voltage checking.

Technical Specifications

| MODEL NO. | TF-9700 |
|------------------------------------|--------------------|
| Input voltage | AC380-440V 50/60Hz |
| Input power | 26.8KVA |
| Input current | 60A |
| Max welding current | 9900A |
| Output voltage carbon rod heating | AC6-10V |
| Output voltage washer melting rate | AC1-12V |
| Output voltage butt-weld | AC1-13V |
| One-side welding thickness | 1.0+1.5mm |
| Two-side welding thickness | 2.5+2.5mm |
| Air supply pressure | 6-10kg |
| Weld timing range | 0-99min |
| Cable length | 2300+2300mm |
| G. Weight | 138kg |



MIG WELDING MACHINE (TF-850)

Product Description

The Techfanatics MIG semi-automatic gas shielded welding machines are suitable for all positions and for the highspeed welding of sheet metals and medium plates.

Main Features

- ☑ Digital display
- ☑ Wire feeder with drive system
- ☑ Complete with heated regulator
- ☑ Adjustable dynamic arc characteristic
- ☑ Good forming capability and quality weld appearance
- ☑ Auto-detect function

Technical Specifications

| Model No. | TF-850 |
|---------------------------|------------------------|
| Input Voltage / Frequency | AC 220V-380V / 50/60Hz |
| Input power | 3.5kw |
| Input current | 20Amp |
| Insulation Grade | H |
| Wire Diameter | 0.8-1.0mm |
| Output current/voltage | 20-38V |
| Welding current range | 15-250A |



PLASMA CUTTER (TF-50)

Main Features

- ☑ IGBT inverter innovation
- ☑ Compact size, light weight, high effectiveness and energy saving.
- ☑ ABS plastic body with amazing protection execution and corrosion resistance.
- ☑ Cutting velocity is a lot quicker than oxyfuel slicing by up to 1.8 times.
- ☑ Thick metal plate can be cut effectively, rapidly and monetarily.
- ☑ Suitable for cutting stainless steel, copper, carbon steel, aluminium etc.
- ☑ Basic activity, smooth cutting surface.
- ☑ HF bend beginning with contact.

Technical Specifications

| Model No. | TF-50 |
|----------------------|----------------------------|
| Input power voltage | AC220V Single phase 50/6Hz |
| Rate input power | 30A |
| No-load voltage | 230V |
| Output current range | 15-40A |
| Rated output voltage | 94V |
| Duty cycle | 35% |
| Efficiency | 80% |
| Insulation class | B |
| Protection class | IP23 |
| Arc-starting | contact |
| Gas flow | 0.17 m3/min |
| No-load loss | 60W |
| Cutting thickness | 8-10mm |
| Overall dimension | 410x165x260mm |



INFRARED DRYER (TF-100/TF-200/TF-300)

Product Description

The infrared light tubes with 1200 watt each is drying quicker than any time in recent memory. With the IR Paint protection Coating Dryer you can reduce the drying and curing time to minimum. It takes just 15 minutes for each panel with the IR Paint Protection Coating Dryer which ordinarily can take 12+ hours.

It is ideal for expert detailers with restricted space who can't have a vehicle for at least 12 hours simply remaining there consuming the working space. We have Single tube double tube triple tube options for Our Valuable Customers.



PAINT SPRAY BOOTH

Product Description:

We are occupied with showing a magnificent evaluation of Paint Booth 7 M with Extra Wide Cabin. This cabin is produced utilizing CNC machines and pre-coated sheet metals. The offered cabin has reverse blade direct mounted turbine ensures low electric consumption and consistent air flow reliability. Also, such cabin is furnished with full filtered ceiling that has simple four element rack ensuring fast and easy service.



Main Features

- ▣ Total air exhaust
- ▣ Brake free position
- ▣ Circuit solution and circulation
- ▣ Demonstrated Design and Economics at many significant body shops.
- ▣ Totally fabricated on most recent age CNC machines utilizing pre-covered sheet metals.
- ▣ Turn around Blade Direct Mounted Turbine guarantees low electric utilization, consistent airflow unwavering quality. no belts or pulleys requiring support.
- ▣ The circulation inside the generator ensures high level of fuel efficiency.
- ▣ Full filtered ceiling. simple four element rack ensures fast and easy servicing. self-sealing panels eliminate the need for additional gaskets.
- ▣ Calculated light apparatuses give even conveyance of light, wiping out shadows and glare.
- ▣ Pre-covered sheet metal utilized inside with 4 surface coatings.
- ▣ Outside sheet metal in with 3 surface coating galvanised finish.
- ▣ Fully insulated wall panels. tongue and groove joints for self-centering airtight fit and increased strength
- ▣ Front 3 folding door system with large glass windows fitted with new generation locking system and imported anti-panic system

Technical Specifications

| Model No. | TF - 1200 SPRAYTECH | TF - 1600 SPRAYTECH |
|-------------------------|------------------------|------------------------|
| Outside dimensions | 6900 x 3890 x 3260 mm | 7000 x 5350 x 3400 mm |
| inside diamensions | 6750 x 3790 x 2660 mm | 6900 x 3900 x 2650 mm |
| Main door dimensions | 2880 x 2570 mm | 3000 x 2600 mm |
| Service door dimensions | 630 x 1780 mm | 650 x 1800 mm |
| Flow Rate | 18000 m3/h | 23000 m3 /h |
| Air velocity | 0.2 - 0.3 m/s | 0.2 -0.5 m/s |
| Working temperature | 60-80°C | 60-80°C |
| Oil Consumption | 5-7 kg/car | 5-7 kg/car |
| Lighting intensity | 700 Lux | 650 -700 Lux |
| Sound level | <80 dba | <80 dba |
| Application vehicle | Wagon or passanger car | Wagon or passanger car |
| Power supply | 380V AC, 3 Phase, 50Hz | 380V AC, 3 Phase, 50Hz |
| Power | 9 HP | 16 HP |

AUTOMOBILE SHEET METAL BEAM CORRECTION DEVICE (TF-8000)

Main Features

- ☒ Unilateral tilting hydraulic lifting platform makes it simple for the vehicles to drive on.
- ☒ The material is rectangular tube together with flat plate platform and numerous stations holes is convenient for fixing any tools.
- ☒ The working range of pulling towers is 360°. Simple operation.
- ☒ Streamline clamps can fasten almost all various damaged vehicles.
- ☒ High-precision measurement system can be easily used to perform the dimension measurement on the car, control body size and the same as the original cars.
- ☒ Impeccable after deals administration ensures for clients' fulfillment.

Technical Specifications

| Model No. | TF-8000 |
|--------------------------|---------|
| Bench length | 5200mm |
| Bench width | 2120mm |
| Working height | 520mm |
| Post Max.pulling tension | 8tons |
| Pneumatic pressure range | 0.8MPa |
| Post working range | 360° |
| Max.Lifting weight | 3500kg |
| G. weight | 2200kg |



INJECTOR CLEANER (TF-400)

Product Description

Injector Cleaner can perform cleaning and Testing of all sort of top feed and side feed multipoint, mono/single point fuel injectors for a wide range of MPFI vehicles.

Main Features

- ☒ Clean
- ☒ Pulse Flow Test
- ☒ Drain
- ☒ Leak Test
- ☒ R.P.M Test (500-9000)



BATTERY CHARGER (TF-1224)

Product Description

Digital Battery Charger, provided by Techfanatics, can Charge 4&6 nos. batteries (Selectable) at a time.

Technical Specifications

- ☒ Selectable Voltage : 12V-24V-36V-48V-60V-72V optional
- ☒ Current : 0-10 Amps
- ☒ Accessories : Battery Charging Lead with End Clips – 1 Pair



BATTERY BOOSTER (TF-1272)

Product Description

Techfanatics Quick Battery Booster can be utilized as quick battery Charger. fast Battery Booster. Adopt the most practical and reliable advanced technology and process; Adopt multi-layer bridge rectifier bridge; HUA curved silicon steel sheet, high efficiency and energy saving main transformer; Control system with multi functional display of voltage and current; Auxiliary start (family car), fast and slow changing (12-24V); 12 Volt Multiple Pieces can be connected in parallel for charging

Technical Specifications

| Model No. | TF-1272 |
|------------------|--------------|
| Input Voltage | 220V 50/60HZ |
| Start Voltage | 13-16V |
| Charging Voltage | 10-14V |
| Starting Current | 3500A |
| Charging Current | 60A |
| Size | 39X35X76CM |
| G. weight | 45kg |



SPARK PLUG CLEANER (TF-700)

Product Description

Separate plug cleaning chamber comprising of a rough system associated with double acting valve for blasting and consequent cleaning to evacuate the grating and residue. Different rubber adapters accommodated cleaning attachments of 10 mm, 12 mm, 14 mm and 18 mm sizes.



HEAD LIGHT BEAM ALIGNER (TF-130)

Technical Specifications

| Model No. | TF-130 |
|--------------------|--|
| Measuring Range | Central Height of Headlight: 50cm~130cm Light Intensity: 0~60,000cd (Standard) 0~100,000cd (maximum) |
| Resolution | Light Intensity of High Beam : ±100cd |
| Indication Error | Light Intensity of High Beam : ±12% |
| Measuring Distance | 30~50cm |
| Power Consumption | <0.5W (for complete machine) |
| G. Weight | 30Kg |



ENGINE DECARBONIZING MACHINE (TF-500 ED)

Main Features

- ❑ Hard core working switches given for maintenance free operation.
- ❑ Quick release couplers (QRC) are given toward the part of the bargain to keep away from chemical spillage.
- ❑ Machine will sound up at the end of decarbonizing process.
- ❑ Straightforward oil level indicators available on each tank.
- ❑ Machine will stop pump in case of low chemical level for pump safety.
- ❑ Appropriate for Diesel & Petrol Vehicle. Combine is optional.

Benefits

- ❑ Fuel saving up-to 15%
- ❑ Restore power by 40%
- ❑ Enhanced engine life
- ❑ Pollution control up-to 50%
- ❑ Smoother vibration free ride



AC GAS RECOVERY MACHINE (TF-1200)

Product Description

Techfanatics has earned the personality of being solid producer, exporter and provider of AC Gas Charging Machine. Our air conditioning gas charging machine has different highlights, for example, elite, vitality effective, reliable, and so on. That are in charge of its wide request in the worldwide markets. We can give air conditioning gas charging machine at market leading costs.



| Functions | Technical Specifications |
|-----------------------------------|----------------------------|
| Recovery | Voltage: AC220V~50/60Hz |
| Vacuum | Vacuum pump: 4.5CFM / 10Pa |
| Manual oil inject | Compressor: 12cc |
| Quantitative recharge | Tank scale precision: ±10g |
| Multifold alarm | Max pressure: 17.5bar |
| Maintenance program | Tank capacity: 10L |
| Electric scale | LED display |
| Parameter settings | |
| Automatic / Manual drain used oil | |



DUST-FREE SANDING MACHINE (TF-150)

Product Description

IC control electric, pneumatic synchronous boot function
Triple filtration system
Two grinding machines can work simultaneously
Unique water filtration function, true dust-free zero emission, can be matched with electric function

| Model No. | TF-150 |
|-----------------------|----------------------|
| Input Voltage | 220V |
| Rated Power | 1.6kw |
| Dust Bag Capacity | 30L |
| Air Volume | 220M ² /H |
| Min. Working Pressure | 6KGS/CM |
| Size | 60X38X58CM |
| G. weight | 30kg |

CAR SCANNER LAUNCH (X-431 PRO)

Technical Specifications

| Model No. | X-431 PRO |
|------------------|---|
| Operating System | Android |
| CPU | Dual Core 1GHz |
| Battery | 3000mh chargeable polymer lithium battery |
| Memory | 512MB Storage |
| Touch Screen | Five point capacitive touch screen |
| Cameras | 2MP rear and 0.3MP front |
| Bluetooth | Enabled |



TOOL TROLLEY (TF-4D)

Product Description

Techfanatics offering best range of different tool trolley's with rugged caster wheel and haggle quality metal sheet most preferable three drawer from our customers

Main Features

- ☑ Attractive look
- ☑ Superior finish
- ☑ Alluring design



OIL COLLECTOR (TF-450 OC)

Product Description

Techfanatics Manufacture the optimum quality of Waste Oil Collector.

Technical Specifications

Tank Capacity: 80 Ltr
Weight (Approx): 15-20 kg



ENGINE CRANE (TF-2.0)

Main Features

- ☑ Heavy gauge welded steel development
- ☑ Uncompromising full swivel casters give simple mobility what's more, situating
- ☑ Extending blast allows numerous length modifications
- ☑ Wide base gives controlled bringing down
- ☑ Produced steel grab hook
- ☑ Limit 0.5 to 2 Ton



TRANSMISSION JACK (TF-1.5)

Main Features:

- ☑ Tough steel haggles swivel ball bearing casters
- ☑ Multi adjustment handles guarantee that transmission support is consistently at the privilege point to position and acknowledge any load
- ☑ Load restraining chain is imperative for raising and lowering safety
- ☑ Four wheel casters allow easy movement, positioning of transmission jack



HYDRAULIC PRESS (TF-20)

Product Description

Techfanatics offering Professional hydraulic press Hydraulic power unit provides smooth pressing action and simple operation Substantial all steel frame development with rust proof complete for longer device life rock solid double return springs withdraw ram rapidly and with exact control capacity 6,12, 20, 30 ton



TYRE VULCANIZING MACHINE (TF-05)

Product Description

This arrangement is outfitted with 5 fine quality plates which fits the repair needs of tyre crown, tyre shoulder. It additionally accompanies timer, Signal and circuit Protection. Upper and base iron can work either independently or together.



RIM STRAIGHTENER (TF-70R/TF-140R/TF-200R)

Techfanatics offering 7 die, 14 Die & 20 Die Rim Straightening Machine



Main Features

- ☑ With double dies at centre removes bend accurately.
- ☑ Heavy damaged rims at corner can also be straightened accurately.
- ☑ Die Attachment for 4", 4½", 5", 5½", 6", 6½" Rims.
- ☑ Power : 220 V Ac Single Phase
- ☑ Motor : 2 hp 1440 rpm
- ☑ Tools have to be changed for different sizes.

TYRE INFLATOR (TF-2200)

Main Features

- ☑ Designed for petrol pumps and service centers
- ☑ Extremely rugged and reliable design
- ☑ Large backlit 1" Dual Digital Display
- ☑ Automatic filling speed adjustment using intelligent software ensures fast inflation
- ☑ Safe with self diagnostics and always confirms high accuracy on set point to avoid wrong set point entry



TRUCK WHEEL ALIGNMENT (TF-2000 CV)

Main Features

- ☒ Remote Bluetooth innovation, guarantee great conveying intersections in 25 meters.
- ☒ Sensor sheets receive the fix wave patching process, CPU embraces American Intelligent rapid information obtaining innovation, ensure the failure rate will in general zero.
- ☒ European tilt point sensors, high precision and brisk measuring speed, sensors with capacity of programmed caution and charging sign.
- ☒ Online electronic levels to screen level condition, precision accomplishes 0.01 degree.
- ☒ Programmed estimation of toe and camber, professional comprehensive adjustment system.
- ☒ Quit working following five minutes, sensors can be off automatically.
- ☒ Max estimation length can accomplish 25 meters, Max clamping size accomplishes 30".
- ☒ Unique offer remuneration system, reduce the effects of rim deformation on measuring results.
- ☒ Extraordinary entire vehicle and front pivot measurement system, 10 minutes to measure entire vehicle and 5 minutes to quantify front axle.



Technical Specifications

| Model No. | TF-2000 CV | |
|---------------------------|------------|------|
| Toe angle | ±1' | ±5° |
| Total toe angle | ±1' | ±10° |
| Camber | ±1' | ±60° |
| kingpin caster angle | ±5' | ±40° |
| kingpin inclination angle | ±5' | ±40° |

TRUCK WHEEL BALANCER (TF-1400 CV)

Main Features

- ☒ This product makes fine balancing for tyres of various light truck and bus, transport vehicles.
- ☒ It can understand programmed dynamic balance, static balance and aluminium alloy rim balance.
- ☒ The protective cover is optional.
- ☒ Foot brake function makes simple brake.

Technical Specifications

| Model No. | TF-1400 CV |
|--------------------|----------------|
| Rim diameter | 10"-26" |
| Max. tyre diameter | 1200mm |
| Tyre width | 1.5"-20" |
| Max. tyre weight | 150kg |
| Spindle speed | 200r/min |
| Balance precision | ±10g |
| Motor | 220V/380V/550W |



TRUCK TYRE CHANGER

Product Description

Techfanatics truck tyre changer is the ideal decision for the enormous truck workshop/tyre center that does high volume truck tyre work. The automatic features of this truck tyre changer enable the administrator to definitely decrease the time it takes to mount and demount a truck tyre.

Main Features

- ☒ Durable reduction gearbox
- ☒ High-efficiency motor
- ☒ Ease of use bead breaker disk and mounting tool
- ☒ Emergency switch
- ☒ Safely monitor all tyre changing operations
- ☒ Portable control console

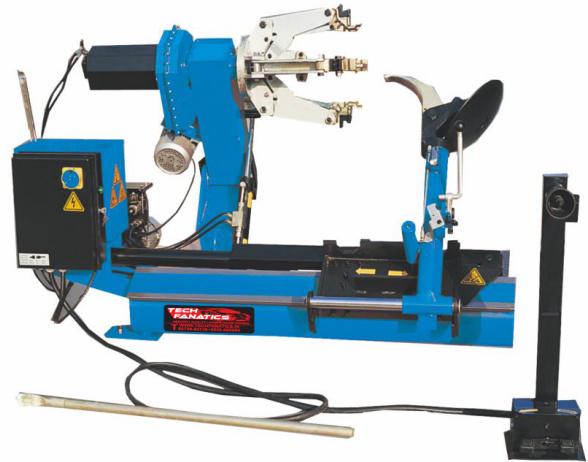

Technical Specifications

| Model No. | TF-300 CV | TF-400 CV | TF-500 CV |
|-----------------------|-------------------------------|--------------|--------------|
| Pump motor | 220v (1ph)/380v(3ph); 1.5kw | 2.2kw | 3.0kw |
| Rotating motor | 220V (1ph)/ 380V (3ph); 2.2kw | 2.2kw | 2.4kw |
| Clamping capacity | 14"-26" | 14"-42" | 14"-56" |
| Maximum tyre diameter | 1600mm (63") | 2300mm (90") | 2500mm (98") |
| Maximum tyre width | 780mm (30") | 1050mm (41") | 1200mm (47") |
| Maximum tyre weight | 500kg | 1200Kg | 2200Kg |
| G. weight | 520Kg | 774kg | 960kg |

TRUCK PNEUMATIC GUN

1" drive long shank impact wrench tool.

- ☒ Torque : 2400 NM/ 3400 NM / 5000 NM
- ☒ 4000 RPM
- ☒ 1900 Foot pounds maximum torque
- ☒ Super 8" long anvil
- ☒ Requires 6-9 Bar
- ☒ Air inlet: 1/2" NPT
- ☒ Forward and reverse settings
- ☒ Long shank for truck tires
- ☒ Includes 2 1" drive impact sockets



VEHICLE TEST LANE MACHINE (TF-5800)

Product Description

Braking execution is the most significant presentation in a vehicle, brake execution testing plans to check whether the total and reliable appraisal of brake, braking execution is steady with the national standard necessities.

The device has been made a national specialized supervision divisions of the measurement affirmation. Test roller surface is sticky sand, reducer and motor with incorporated plan, standard parts all utilization elevated requirement segments. measurement information through the digital display, brake bend yield by the printer port, a sequential correspondence interface to encourage meter testing station network. The gadget has a precise measurement, simple operation, clear display and full-highlighted etc.



Main Features

- ☑ Using industrial computer control equipment.
- ☑ With anti-moisture, anti-dust, anti-humidity, anti-electromagnetic interference function.
- ☑ With high unwavering quality, testing as indicated by exact.
- ☑ The software calibration function.
- ☑ The software functions to alter parameters.
- ☑ The device of latest design, simple structure, easy to use.

Brake and axle load tester

Sideslip tester



Technical Specifications

| Model No. | TF-5800 | | | |
|------------------------------------|-----------------------------|-------------------|----------------------------|---------------|
| The maximum allowable axle load | 10000kg (3000kg-10000kg) | | | |
| Test-bed shape reference dimension | 3990mm*840mm*635mm(10t) | | | |
| Drum size | 195mm,300mm | | | |
| Roller spacing | 430mm - 470mm | | | |
| Brake force measurement range | 0 — 30000N(10000N,45000N) | | | |
| Axle load measuring range | 0 — 10000kg(3000kg,15000kg) | | | |
| Measuring range | ≤3% | | | |
| Rated conditions of use | Ambient temperature | Relative humidity | Power | Rated Voltage |
| | -20 Centigrade50 Centigrade | ≤85% | Motor:AC220V, Motor:AC380V | -15% — +10% |

PNEUMATIC GUN

Product Details

| | |
|--------------------------------|---------------------------------------|
| Max Torque(Nm) | 300Nm, 500Nm, 720Nm |
| Air Pressure (psi) | 120 psi, 100-120 psi |
| Drive Size (inch) | 3/8" to 1/2", 1/2" to 1", >1", 1-1/2" |
| Handle type | Pistol, D-handle Inside Trigger |
| Pneumatic Impact Wrenches from | 3/8", 1/2", 3/4", 1", 1.1/2" |



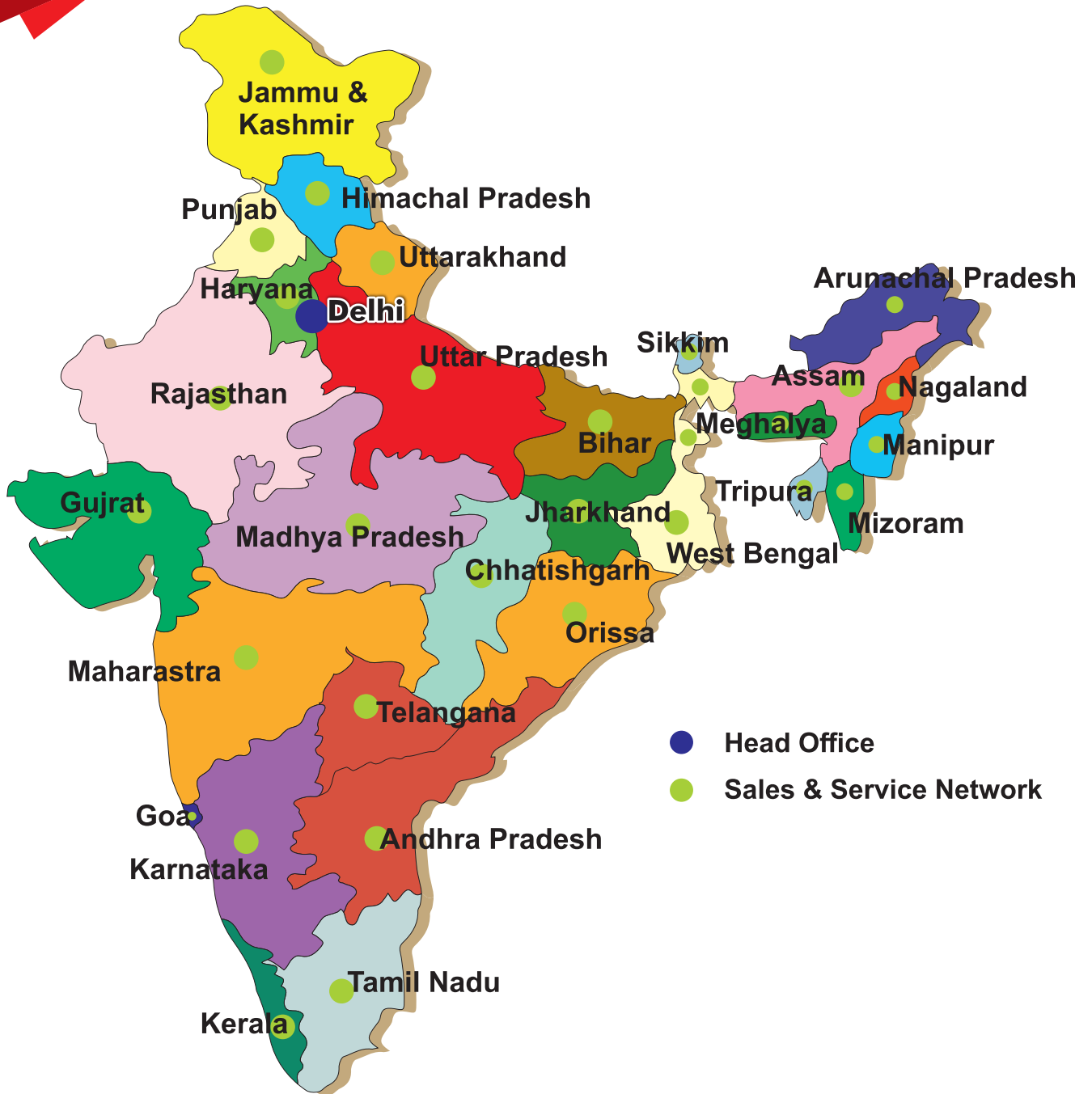

Still not
satisfied?

Call us on

82736-82736

Email

Support@techfanatics.in

We'll do everything to resolve
your issues immediately.



First Point on Techfanatics

QUALITY ASSURED • COMPETITIVE PRICING

Sales Enquiry : sales@techfanatics.in | 82736-82736

Service Enquiry : Service@techfanatics.in | 8539-880000

Call for All your Sales/Service Queries between 9.30am to 6.30pm in all working days.

Customer Service Philosophy

"A customer is the most important visitor on our premises. He is not dependent on us. We are dependent on him. He is not an interruption of our work. He is the purpose of it. He is not an outsider of our business. He is part of it. We are not doing him a favour by serving him. He is doing us a favour by giving us the opportunity to do so."



TECHFANATICS EQUIPMENT LIMITED

Plot No.1, Industrial Area Tikri Kalan, Netaji Subhash Vihar, Delhi-110041



CONTACT US TODAY ON:

- Mob : 82736-82736 | 8539-880000
- LANDLINE : 9599-003539
- Email : sales@techfanatics.in
- Web : www.techfanatics.in

 /techfanatics.equipments

 /techfanatics.equipments

 /@TECHFANATICS