

PressureJet™
EXPLORE THE WATER POWER

High Pressure Triplex Plunger Pumps
For
Fire Fighting Application

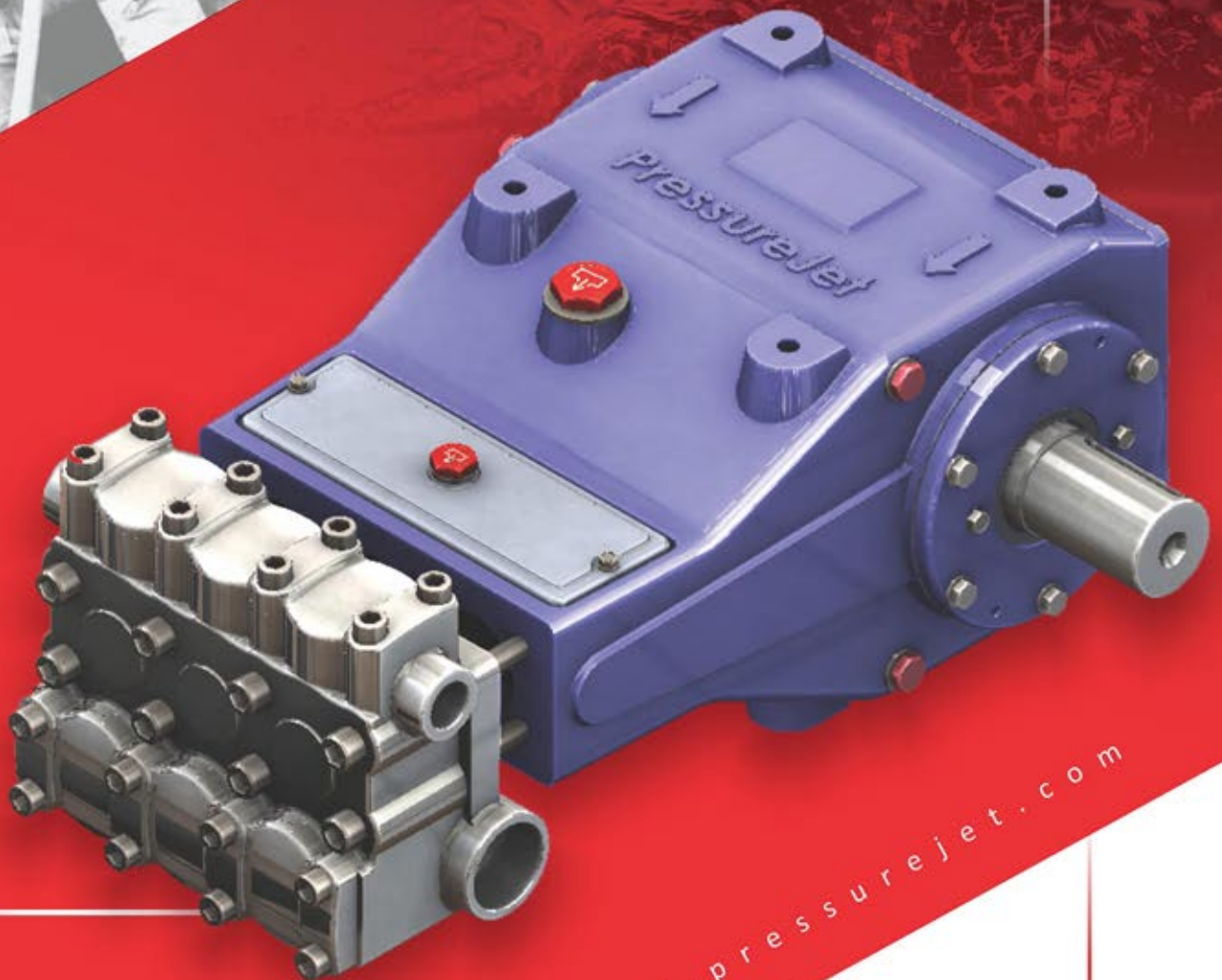

www.pressurejet.com

HIGH PRESSURE PLUNGER PUMP

About Company

PressureJet Systems Pvt. Ltd. was established in 1996 in Ahmedabad, India. PressureJet (an ISO 9001:2008 certified company) is a leading manufacturer of High Pressure, Positive Displacement, Reciprocating Triplex Plunger Pumps, Systems and relevant accessories. These pumps are widely used for various applications like Granite & Marble Texturing, Wet Sand Blasting, Sewer Jetting, Hydro Blasting, Water Jet Cleaning, Hydro test, Descaling, Fire Fighting, Transfer & many more.

Today, PressureJet has a workforce of more than 85 dedicated people. We have 11000 Sq. ft. area in Asia's premier industrial estate in Ahmedabad. Out of which, 5000 Sq. ft. area has been allocated for manufacturing activities.



Our Quality

All components are quality checked in the controlled environment of the QC department. We have the most modern measurement equipment such as 3D CMM (Coordinate Measuring Machine), Surface Roughness Tester, Hardness Tester etc. All components are tracked by barcode system with oracle ERP.



3D modelling is an important aid in designing the technical aspects of engineering product. Simulation can really help in making the correct design decisions during the development stage. At PressureJet, we are using all latest Design Softwares.

HIGH PRESSURE PLUNGER PUMP

Machine Shop



Our Ultra-modern machine shop enables us to manufacture an extremely wide range of components. We can be very flexible in our production planning, while maintaining a high standard of quality with fully automatic machining station. Computer controlled machining stations ensure constant dimensional accuracy.

Assembly & Testing



In this area, all components for the various pump units come together. Pumps and engine or motors are assembled on the skid frame, Accessories such as booster pump, Strainers, PRV, Safety Valve etc. are assembled. PressureJet products are subject to stringent quality control. All pumps are tested at maximum load prior to dispatch for decided time period. All measurement taken during the testing are electronically stored in computer through fully Automatic Test Bench and then it can be printed. Test report is always provided with the pump.

Store / Service



A product is only as good as the service backing it. We have a dedicated team of technicians available for 24 X 7. We keep majority of spares Ex-stock to reduce down time.

HIGH PRESSURE PLUNGER PUMP

Model Selection Graph

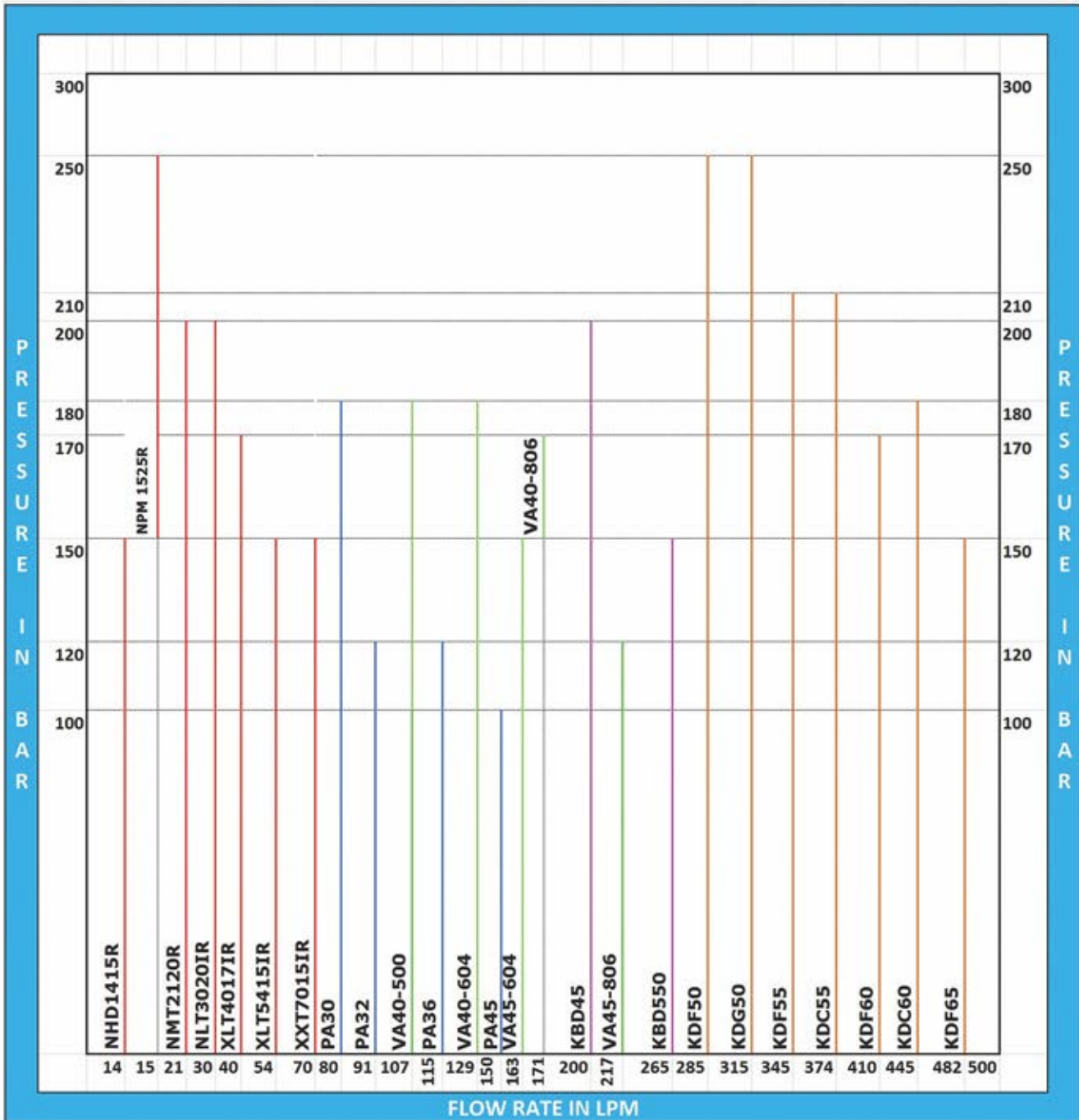





HIGH PRESSURE PLUNGER PUMP

Selection Chart

Pump Selection Chart								
Pump Series	Model	Pump Speed (SPM)	Input RPM Req'd.	Flow Rate in LPM	Pressure in Bar (Min. Engine HP Required)			
HW	NHD1415R	1500	1500	14	150 (8)	100 (5.5)	80 (5)	
	NPM1525R			15	250 (15)	180 (10)	140 (8)	
	NMT2120R			21	200 (16)	180 (15)	130 (11)	
	NLT3020IR			30	200 (23)	155 (18)	125 (15)	
	XLT4017IR			40	170 (26)	140 (23)	95 (15)	
	XLT5415IR			54	150 (28)	130 (27)	100 (21)	
	XXT7015IR			70	150 (32)	130 (28)	100 (27)	
PA	PA30	950	950	80	175 (45)	155 (40)	115 (30)	
	PA32			91	150 (44)	125 (37)	100 (30)	
	PA36			115	120 (45)	90 (29)	-	
	PA45	800	800	150	100 (50)	75 (36)	-	
VA	VA40	1500	1500	500	107	180 (60)	150 (50)	120 (40)
				604	129	180 (72)	140 (56)	100 (40)
				806	171	170 (90)	140 (75)	100 (30)
	VA45			604	163	150 (76)	130 (65)	100 (50)
				806	217	130 (90)	100 (68)	-
				200	200 (124)	150 (93)	100 (62)	
KB	KBD45	600	600	265	155 (127)	130 (107)	100 (82)	
	KBD50			374	210 (244)	185 (216)	155 (180)	
KD	KDC55	500	1500	445	180 (248)	155 (213)	130 (180)	
	KDC60							

Note: (1) Flow rates indicated are at 100% volumetric efficiency. Actual Flow rates will be >90% approx.
(2) All models are suitable for 50 Hz and 60 Hz power specification.

Unloader Valve Selection Chart					
Model	VB 130	Unloader RV	VB 80/280	VB 200/150	VB 450/300
Photo					
Max. Flow Rate (LPM)	25	40	80	200	450
Max. Pressure (Bar)	180	280	310	170	330
Weight	0.39	0.74	1.27	2.02	5.95
Volume	77 X 26 X 112	83 x 50 X 173	96 X 47 X 220	129 X 46 X 225	170 X 62 X 318

HIGH PRESSURE PLUNGER PUMP

HW Series

Salient Features

- Field proven design.
- Forged brass fluid and construction with high strength.
- Rigorously subjected to full load testing.
- Manufactured on state of the art machinery.
- Light in weight & heavy duty construction with intermediate duty model.
- Splash lubrication.
- Available Direct Couple 1450 RPM Drives.
- Easy field maintenance.



Note : (1) Flow rates indicated are at 100% volumetric efficiency. Actual Flow rates will be > 90% approx.
(2) All models are suitable for 50 Hz and 60 Hz power specification.
(3) Gear box is required to operate above pumps at 3000 RPM.

Specifications – HW Series

Sr. No.	Pump Model	Plunger Dia. (mm)	Stroke Length (mm)	Max. Thrust on Plunger (Kgs)	Inlet Connection Size (BSPF)	Outlet Connection Size (BSPF)	Required Suction Pressure	Oil Grade	Oil Capacity (Ltr)	Bare Pump Weight (Kg)
1	NHD1415R	18	13	356	1/2"	3/8"	Flooded	SAE 10W - 40	0.4	6.6
2	NPM1525R		14.5	636					0.7	9.5
3	NMT2120R	22		760					14.8	
4	NMT3020IR		20							17.2
5	XLT4017IR	28	17	862	3/4"	1/2"			1.2	18.4
6	XLT5415IR		20	924	1"	3/4"				
7	XXT7015IR									

Model Selection Chart - HW Series

Model	Pump Speed (SPM)	Input RPM Reqd.	Flow Rate in LPM	Pressure in Bar (Min. Engine HP Required)		
NHD1415R	1500	1500	14	150 (8)	100 (5.5)	80 (5)
NPM1525R			15	250 (15)	180 (10)	140 (8)
NMT2120R			21	200 (16)	180 (15)	130 (11)
NLT3020IR			30	200 (23)	155 (18)	125 (15)
XLT4017IR			40	170 (26)	140 (23)	95 (15)
XLT5415IR			54	150 (28)	130 (27)	100 (21)
XXT7015IR			70	150 (32)	130 (28)	100 (27)

HIGH PRESSURE PLUNGER PUMP

Material of Construction of Major Internal Parts

- 1 **Crank Case (Main Body)**
Crank Case in High Strength Aluminum Pressure Die Casting. With fit led anti friction bush.
- 2 **Crankshaft**
Crankshaft is made of Forged Alloy Steel, with Hardened & Ground.
- 3 **Bearing**
Oversized for maximum life and load disbursement. Self-alignment roller bearing enables it to handle 26% more load than other pumps.
- 4 **Connecting Rod**
Forged Aluminium connecting rods with antifriction bearings. Heavy pin area construction, for added load strength.
- 5 **Piston (Plunger Rod)**
Stainless Steel Construction for hard surface coating and super finish.
- 6 **Pump Head (Manifold Housing)**
Pump head is made of High Strength Forged Brass.
- 7 **Plunger**
High Finish Solid Ceramic Plunger and Surface roughness is extremely good i.e. <math><0.25\text{ Ra}</math> for less wear of Plunger seal.
- 8 **Plunger Seal**
Durable Fiber Impregnated Buna-n Seal packing (Make Parker, Germany) for high compressive & tensile strength ensures effective sealing.
- 9 **Complete Valve**
Valves made of Stainless Steel anti corrosion hard surface coated for long life. High volumetric efficiency, valves operate at more than 95% efficiency.

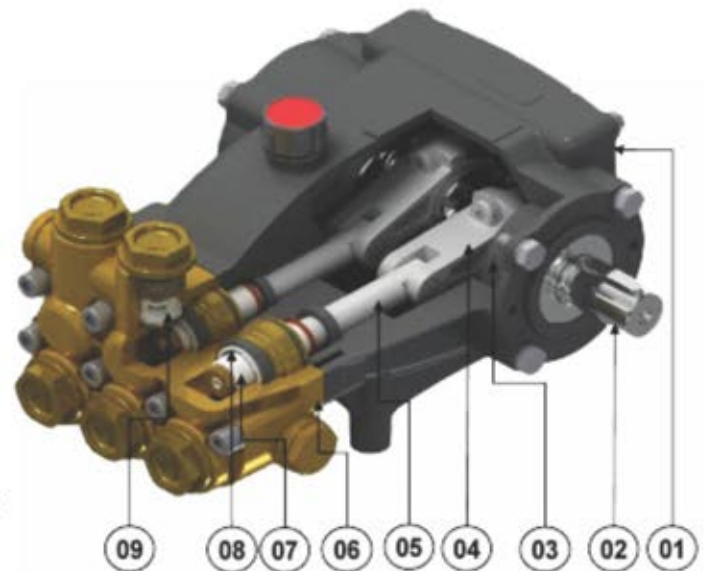

HW Series Bare Pump Dimensions

(All Dimensions are in MM)

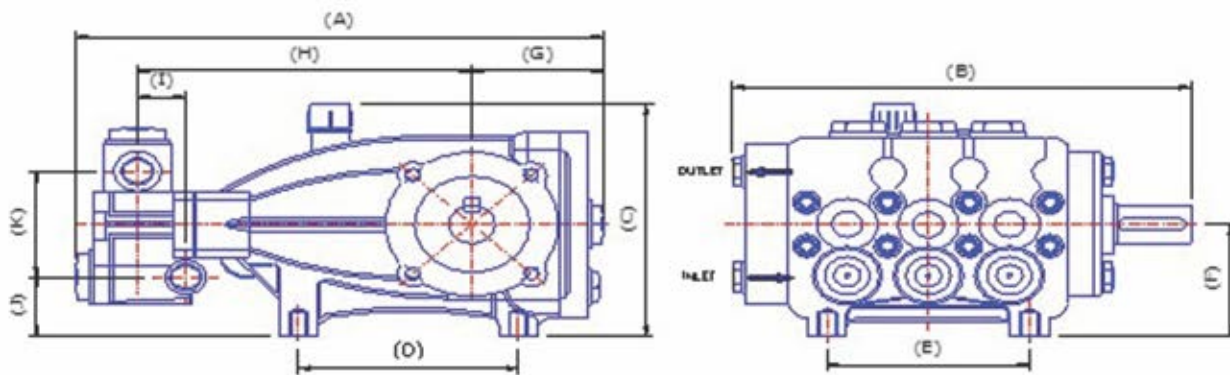

Model	A	B	C	D	E	F	G	H	I	J	K
NHD1415R	250.5	213	135	80	90	60.5	60.5	140	5	30.5	56
NPM1525R NMT2120R	273.5	238	144.5	90	105	70	68	173.5	25	37	66
NMT3020IR	333	248	168.5	105	145	82	81.5	204.5	12	42	77
XLT4017IR XLT5415IR	341	263	168.2	145	105	82	-	217.5	28	35	87
XXT7015IR	344	263	168.5	145	105	82	-	198.5	10	35	91

HIGH PRESSURE PLUNGER PUMP

PA Series

Salient Features

- Field proven design. Easy field maintenance.
- Fluid end construction SG Iron Casting.
- Rigorously Subjected to full load testing.
- Manufactured on state of the art machinery.
- Light in weight (Heavy duty construction, light in weight)
- Splash lubrication.
- Available direct couple or pulley – belts drive.

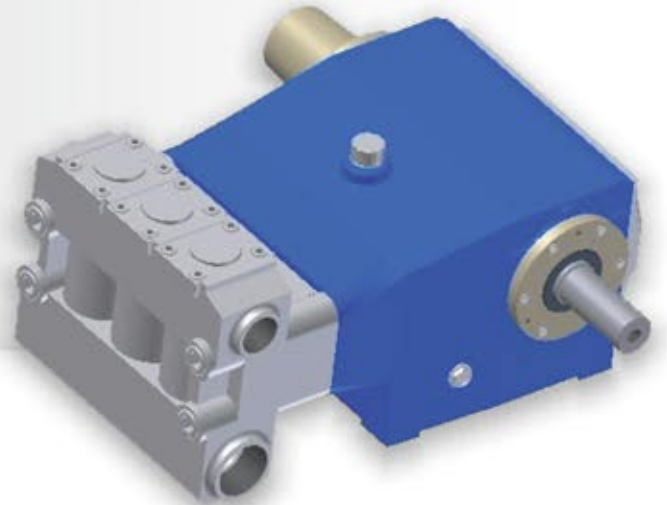

Specification

- Plunger Stroke: 40 mm
- Max. plunger speed: 1.26 m/sec. @ 950 spm
- Plunger force: 12.5 kN (1274 kgf)
- Inlet Pressure min./max.: 1 to 3 bar
- Oil Type: 15W 40
- Oil capacity: 4 ltr.
- Max. Liquid Temp.: 70 °C (160°F)
- Discharge Connection: 1" BSPF
- Suction Connection: 1 ½" BSPF
- Transmission Type: Belt or External Gear
- Dimensions: 475x464x223 (lxbxh) in mm

Model Selection Chart - PA Series

Model	Pump Speed (SPM)	Input RPM Reqd.	Flow Rate in LPM	Pressure in Bar (Min. Engine HP Required)		
				175 (45)	155 (40)	115 (30)
PA30	950	950	80	175 (45)	155 (40)	115 (30)
PA32			91	150 (44)	125 (37)	100 (30)
PA36			115	120 (45)	90 (29)	-
PA45	800	800	150	100 (50)	75 (36)	-

Note:

- (1) Flow rates indicated are at 100% volumetric efficiency. Actual Flow rates will be > 90% approx.
- (2) All models are suitable for 50 Hz and 60 Hz power specification.

HIGH PRESSURE PLUNGER PUMP

Material of Construction of Major Internal Parts

Power End

- 1 **Crank Case (Main Body)**
Grey Iron : Main body in grey iron casting FG-260. With Honed surface finish bore.
- 2 **Crankshaft**
Spheroidal Graphite Iron : Crankshaft is made of nitrated, hardened and tempered Spheroidal Graphite Iron casting.
- 3 **Connecting Rod**
Alloy Steel : Forged steel connecting rods with antifriction bearings. Heavy pin area construction, for added load strength.
- 4 **Piston / Cross Head**
Alloy Steel : Alloy steel construction for hard surface coating and super finish.
- 5 **Bearing**
Oversized for maximum life and load disbursement. Self-alignment roller bearing enables it to handle 26% more load than other pumps.

PA Series Bare Pump Dimension

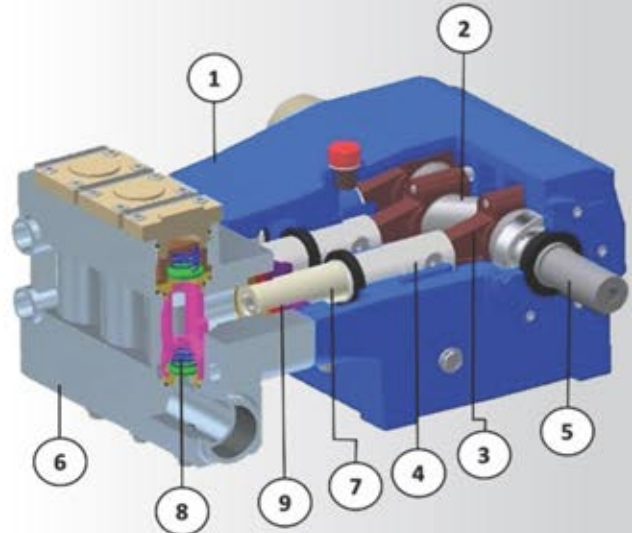
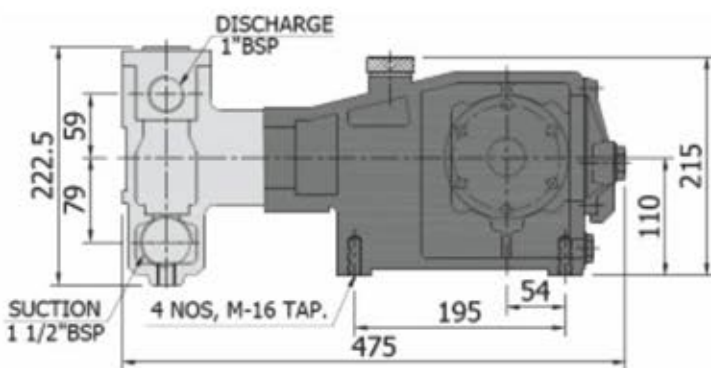
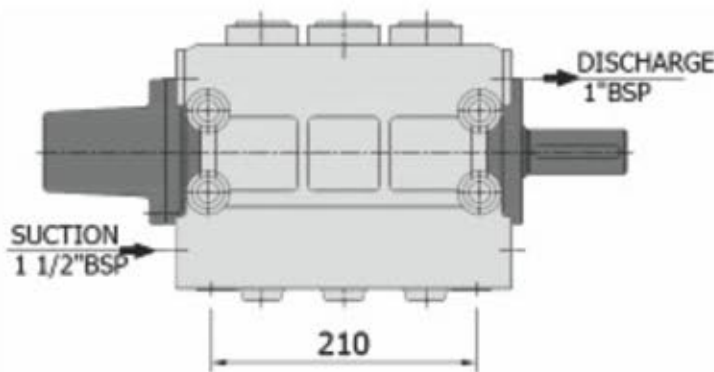

Fluid End

- 6 **Pump Head**
SG Iron : Pump Head is Made of SG Iron Casting.
- 7 **Plunger Ceramic Coated**
Primarily composed of ceramic coated. Surface roughness is extremely good i.e. <0.2 Ra.
- 8 **Complete Valve Internal (Valve Assembly)**
Stainless Steel : Valves made stainless steel for hardened & anti corrosion hard surface coated for long life. High volumetric efficiency valves operate at 95% efficiency plus.
- 9 **Plunger Seal**
Chevron Seal : "V" style strong and tightens under load packing for high compressive & tensile strength ensure effective sealing.

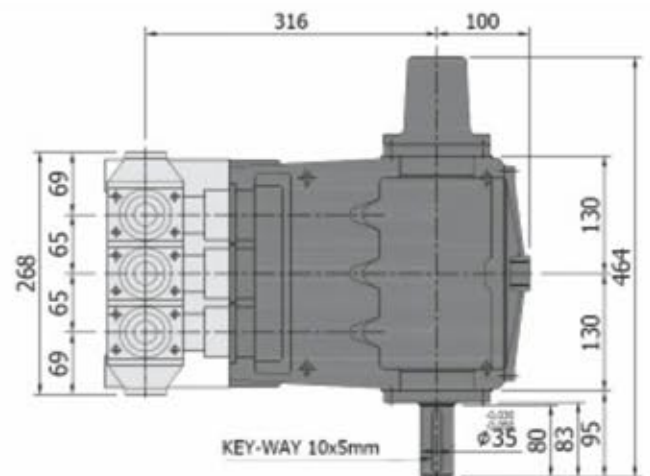

All Dimensions are in mm and Bare Pump Weight – 83 Kgs.

HIGH PRESSURE PLUNGER PUMP

VA Series

Salient Features

- Casting stainless steel pump head construction with high strength.
- Light in weight & heavy duty construction.
- Splash lubrication.
- Easy field maintenance.
- Both side mounting available.
- Pumps design suitable for inbuilt gear & belt drive.

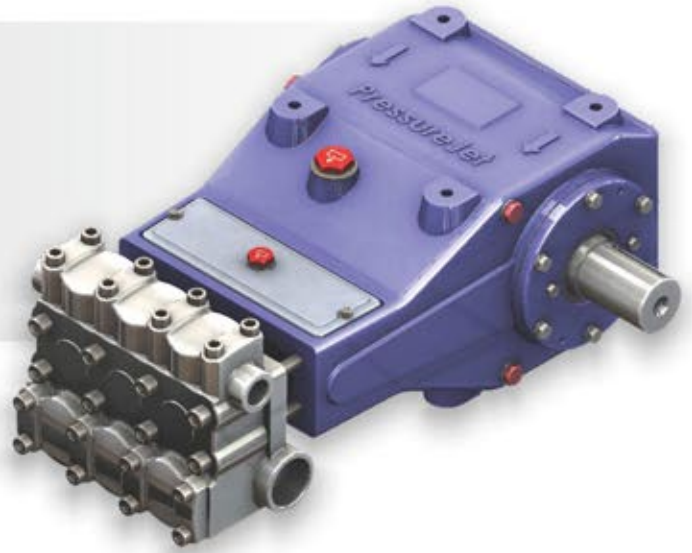

Bare Pump with Gear Box



Specification

- Plunger Stroke: 57 mm
- Max. plunger speed: 1.14 m/sec. @ 600 spm
- Plunger force: 23.5 kN (2400 kgf)
- Required Inlet Pressure: Flooded
- Oil Type: SAE – 80 W 90
- Oil capacity: 8 ltrs.
- Max. Liquid Temp.: 70 °C (158 °F)
- Discharge Connection: 1" BSPF
- Suction Connection: 2" BSPF
- Transmission Type: External Gear
- Dimensions: 716x501x264 (lxbxh) in mm

Model Selection Chart - VA Series

Model	Pump Speed (SPM)	Input RPM Reqd.	Flow Rate in LPM	Pressure in Bar (Min. Engine HP Required)		
VA40	500	1500	129	180 (72)	140 (56)	100 (40)
	604		138	200 (80)	140 (60)	100 (43)
	806		155	180 (87)	130 (62)	100 (48)
VA45	604		163	150 (76)	130 (65)	100 (50)
	806		217	170 (90)	140 (75)	100 (30)

Note : (1) Flow rates indicated are at 100% volumetric efficiency. Actual Flow rates will be > 90% approx.
(2) All models are suitable for 50 Hz and 60 Hz power specification.

HIGH PRESSURE PLUNGER PUMP

Material of Construction of Major Internal Parts

Power End

- 1 **Crank Case (Main Body)**
Grey Iron : Main body in grey iron casting FG-260 with Honed surface finish bore.
- 2 **External Helical Gear Box**
Alloy Steel : Helical gear is nitride hardened and precision ground for extremely long life and durability.
- 3 **Bearing**
Oversized for maximum life and load disbursement. Self-alignment roller bearing enables it to handle 26% more load than other pumps.
- 4 **Crankshaft**
Alloy steel : Crankshaft is made of nitrated, hardened and precision ground for extremely long life and durability
- 5 **Connecting Rod**
Alloy Steel : Forged steel connecting rods with antifriction bearings. Heavy pin area construction, for added load strength.
- 6 **Piston / Cross Head**
Grey Iron & Stainless Steel : Alloy steel casting piston & stainless steel piston rod are hardened & super finish surface.

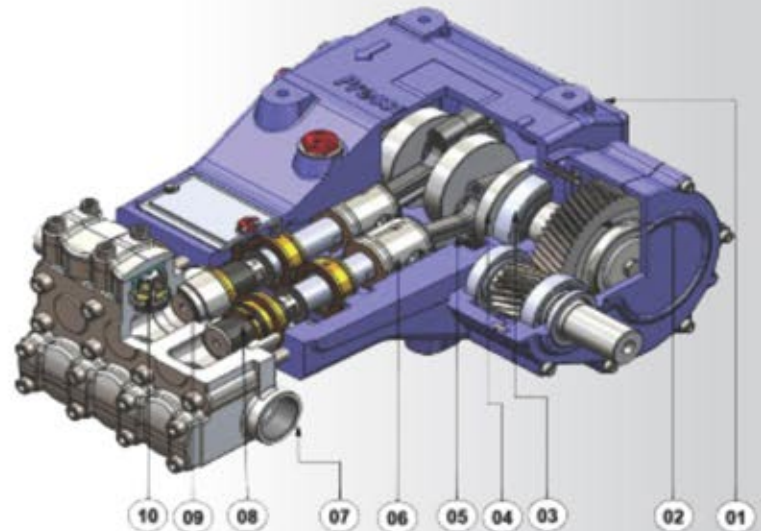

Fluid End

- 7 **Pump Head**
SG Iron : Pump Head is Made of SG Iron Casting.
- 8 **Plunger Ceramic Coated**
Primarily composed of ceramic coated on SS. Surface roughness is extremely good i.e. <0.2 Ra.
- 9 **Plunger Seal**
PTFE Aramide / GFO Aramide rope : Aramide fibre yarn packing with PTFE fibre face or carbonaceous aramide yarn packing with GFO fibre face for high compressive & tensile strength ensure effective sealing.
- 10 **Complete Valve Internal (Valve Assembly)**
Stainless Steel : Valves made of stainless steel for hardened & anti corrosion hard surface coated for long life. High volumetric efficiency valves operate at 95% plus efficiency.

VA Series Bare Pump Dimension

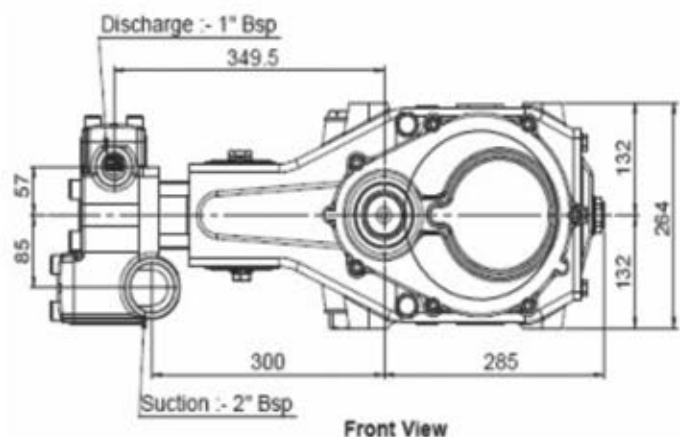
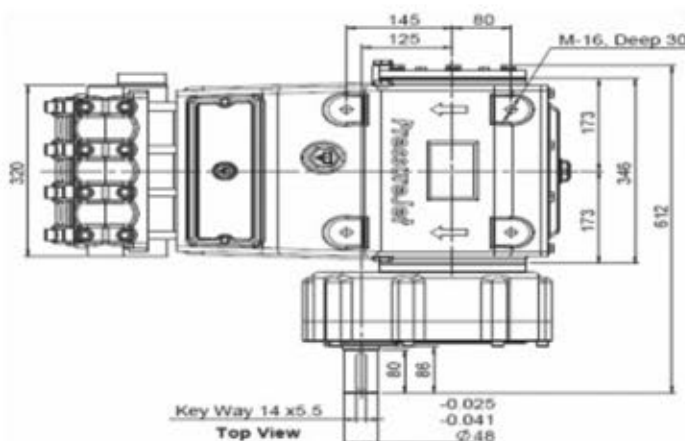

All Dimensions are in mm and Bare Pump Weight – 195 Kgs.

HIGH PRESSURE PLUNGER PUMP

KB Series

Salient Features

- KB Series Designed in built gear.
- Casting stainless steel pump head construction with high strength.
- Light in weight & heavy duty construction.
- Splash lubrication.
- Easy field maintenance.

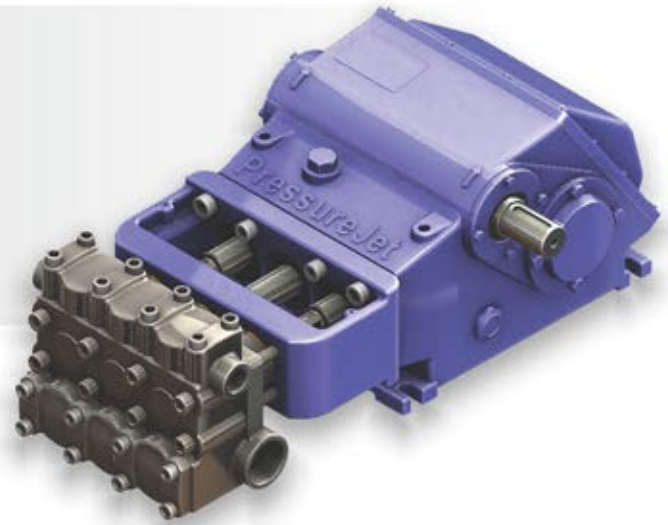

Specification

- Plunger Stroke: 75 mm
- Max. plunger speed: 1.32 m/sec. @ 600 spm
- Plunger force: 31.28 kN (3190 kgf)
- Inlet Pressure min./max.: 2-3 bar
- Oil Type: 80W 90
- Oil capacity: 8 ltrs.
- Max. Liquid Temp.: 70 °C (160°F)
- Discharge Connection: \varnothing G Hole (as per drawing)
- Suction Connection: 2" BSPF
- Transmission Type: Direct Couple (In-built gears)
- Dimensions: 825x442x303 (lxbxh) in mm

Model Selection Chart - KB Series

Model	Pump Speed (SPM)	Input RPM Reqd.	Flow Rate in LPM	Pressure in Bar (Min. Engine HP Required)		
KBD45	600	1500	200	200 (124)	150 (93)	100 (62)
KBD50			265	155 (127)	130 (107)	100 (82)

Note: (1) Flow rates indicated are at 100% volumetric efficiency. Actual Flow rates will be > 90% approx.
(2) All models are suitable for 50 Hz and 60 Hz power specification.

HIGH PRESSURE PLUNGER PUMP

Material of Construction of Major Internal Parts

Power End

- 1 **Crank Case (Main Body)**
Spheroidal Graphite Iron : Main body in spheroidal graphite Iron casting with honed surface finish bore.
- 2 **Crankshaft**
Alloy steel : Crankshaft is made of nitrated, hardened and precision ground for extremely long life and durability.
- 3 **Connecting Rod**
Alloy Steel : Forged steel connecting rods with antifriction bearings. Heavy pin area construction, for added load strength.
- 4 **Piston / Cross Head**
Grey Iron & Stainless Steel : Alloy steel casting piston & stainless steel piston rod are hardened & super finish surface.
- 5 **Pinion Shaft**
Alloy steel : Pinion shaft is nitride hardened and precision ground for extremely long life and durability.
- 6 **Helical Gear**
Alloy steel : Helical gear is nitride hardened and precision ground for extremely long life and durability.
- 7 **Bearing**
Oversized for maximum life and load disbursement. Self-alignment roller bearing enables it to handle 26% more load than other pumps.

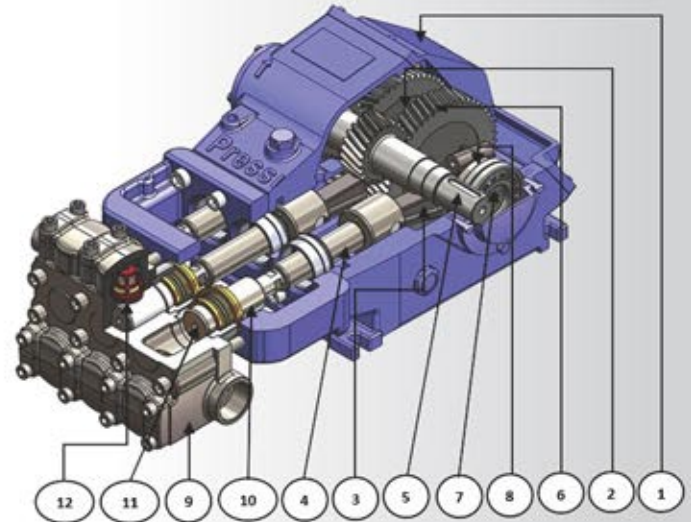

Fluid End

- 8 **White Metal Bearing**
Antifriction bearings for long life of crankshaft
- 9 **Pump Head**
SG Iron : Pump Head is Made of SG Iron Casting.
- 10 **Plunger Ceramic coated**
Primarily composed of ceramic coated on SS. Surface roughness is extremely good i.e. <0.2 Ra.
- 11 **Plunger Seal**
PTFE Aramide / GFO Aramide rope : Aramide fibre yarn packing with PTFE fibre face or carbonaceous aramide yarn packing with GFO fibre face for high compressive & tensile strength ensure effective sealing.
- 12 **Complete Valve Internal (Valve Assembly)**
Stainless Steel : Valves made of stainless steel for hardened & anti corrosion hard surface coated for long life. High volumetric efficiency valves operate at 95% plus efficiency.

KB Series Bare Pump Dimension

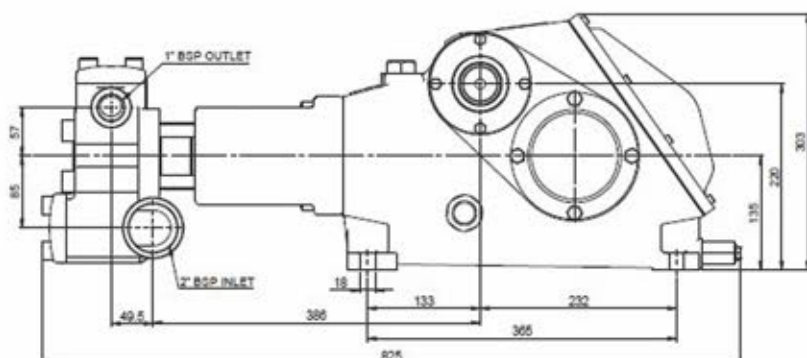
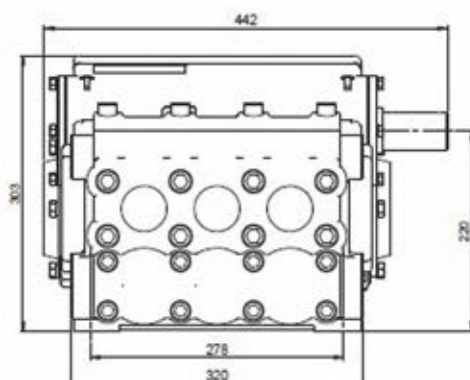
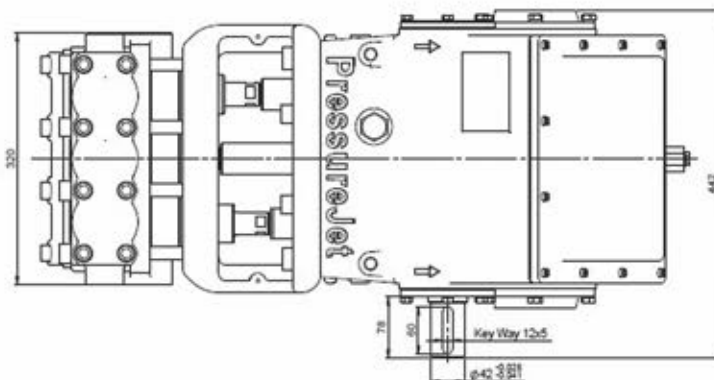

All Dimensions are in mm and Bare Pump Weight – 210 Kg

HIGH PRESSURE PLUNGER PUMP

KD Series

Salient Features

- KD Series Designed in built gear.
- Casting stainless steel pump head construction with high strength.
- Light in weight & heavy duty construction.
- Splash lubrication.
- Easy field maintenance.

Note: (1) Flow rates indicated are at 100% volumetric efficiency. Actual Flow rates will be > 90% approx.
(2) All models are suitable for 50 Hz and 60 Hz power specification.

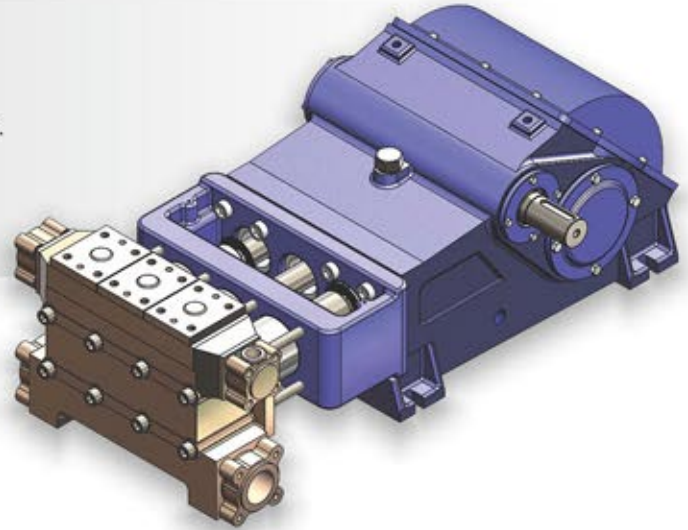

Specification

- Plunger Stroke: 105 mm
- Max. plunger speed: 1.52 m/sec. @ 500 spm
- Plunger force: 40 kN (4080 kgf)
- Inlet Pressure min./max.: 2-3 bar
- Oil Type: SAE – 80 W 90
- Oil capacity: 8 ltr.
- Max. Liquid Temp.: 70 °C (160 °F)
- Discharge Connection: ⌀ G Hole (as per drawing)
- Suction Connection: 3" BSPF
- Dimensions: 1044x531x365 (lxbxh) in mm

Model Selection Chart - KD Series

Model	Pump Speed (SPM)	Input RPM Reqd.	Flow Rate in LPM	Pressure in Bar (Min. Engine HP Required)		
				210 (244)	185 (216)	155 (180)
KDC55	500	1500	374	210 (244)	185 (216)	155 (180)
KDC60			445	180 (248)	155 (213)	130 (180)

HIGH PRESSURE PLUNGER PUMP

Material of Construction of Major Internal Parts

Power End

- 1 **Crank Case (Main Body)**
Spheroidal Graphite Iron : Main body in spheroidal graphite Iron casting with honned surface finish bore.
- 2 **Crankshaft**
Alloy steel : Crankshaft is made of nitrated, hardened and precision ground for extremely long life and durability.
- 3 **Connecting Rod**
Alloy Steel : Forged steel connecting rods with antifricition bearings. Heavy pin area construction, for added load strength.
- 4 **Piston / Cross Head**
Grey Iron & Stainless Steel : Alloy steel casting piston & stainless steel piston rod are hardened & super finish surface.
- 5 **Pinion Shaft**
Alloy steel : Pinion shaft is nitride hardened and precision ground for extremely long life and durability.
- 6 **Helical Gear**
Alloy steel : Helical gear is nitride hardened and precision ground for extremely long life and durability.
- 7 **Bearing**
Oversized for maximum life and load disbursement. Self-alignment roller bearing enables it to handle 26% more load than other pumps.

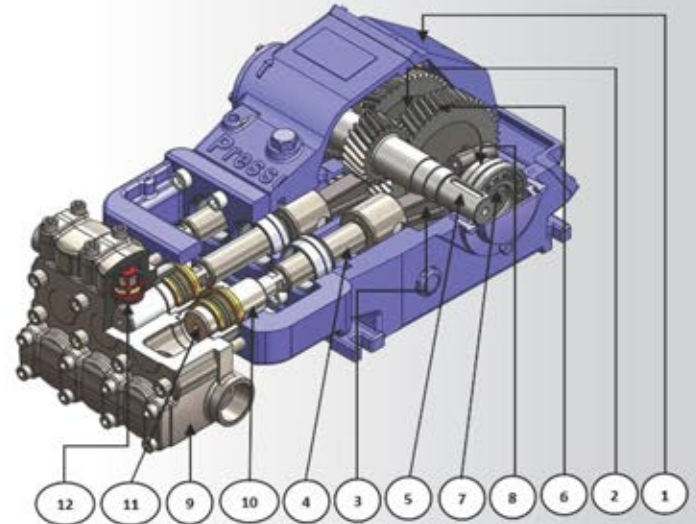

Fluid End

- 8 **White Metal Bearing**
Antifricition bearings for long life of crankshaft
- 9 **Pump Head**
SG Iron : Pump Head is Made of SG Iron Casting.
- 10 **Plunger Ceramic coated**
Primarily composed of ceramic coated on SS. Surface roughness is extremely good i.e. <math><0.2 \text{ Ra}</math>.
- 11 **Plunger Seal**
PTFE Aramide / GFO Aramide rope : Aramide fibre yarn packing with PTFE fibre face or carbonaceous aramide yarn packing with GFO fibre face for high compressive & tensile strength ensure effective sealing.
- 12 **Complete Valve Internal (Valve Assembly)**
Stainless Steel : Valves made of stainless steel for hardened & anti corrosion hard surface coated for long life. High volumetric efficiency valves operate at 95% plus efficiency.

KD Series Bare Pump Dimension

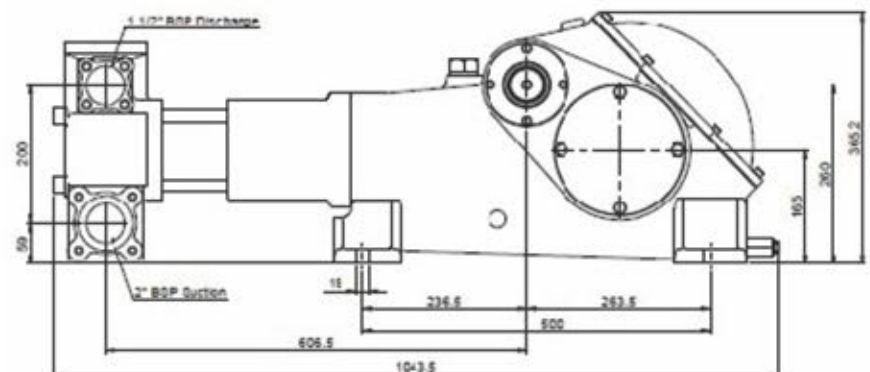
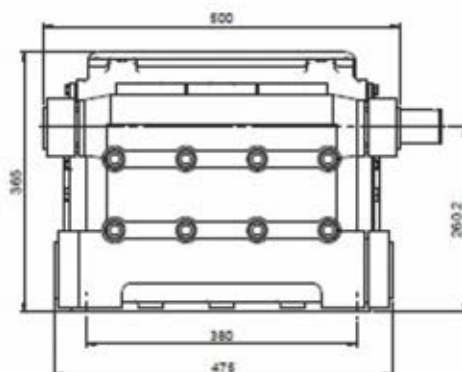
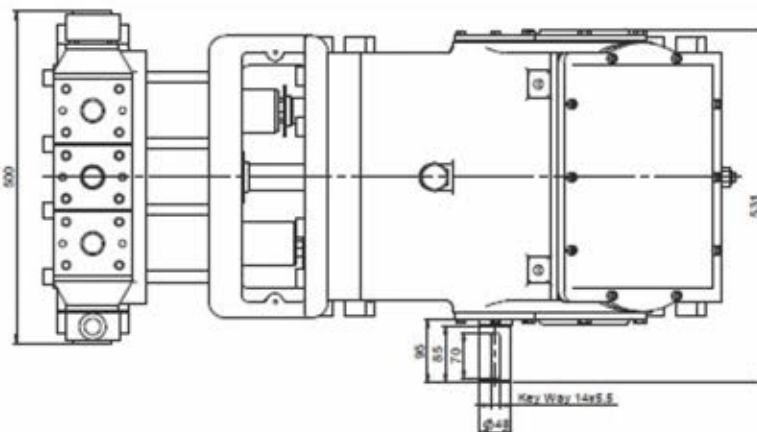

All Dimension are in mm and Bare Pump Weight – 340 Kg

Foam Gun



Model: RL – 24
 Max. Flow: 30 LPM
 Max. Pressure: 200 Bar
 Weight: 1370 gram
 Temp: 60° C

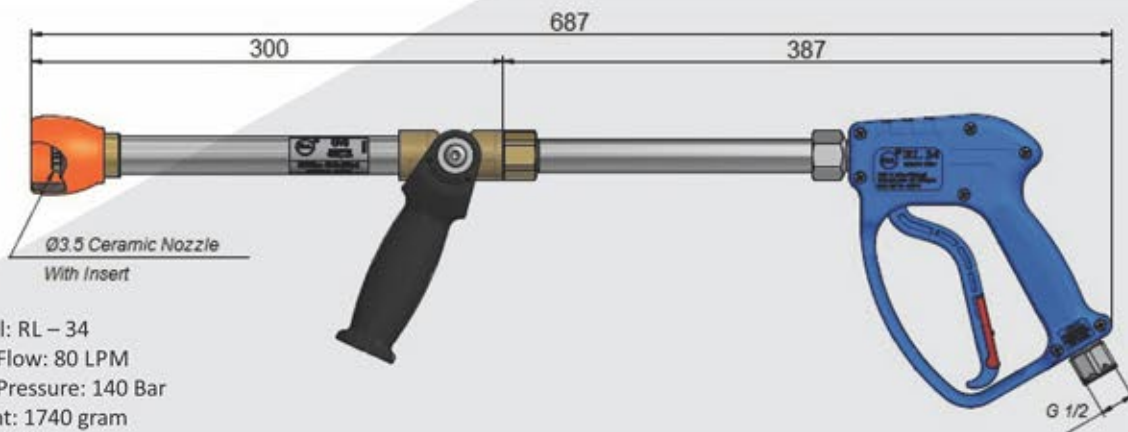

Model: RL – 34
 Max. Flow: 80 LPM
 Max. Pressure: 140 Bar
 Weight: 1740 gram
 Temp: 60° C

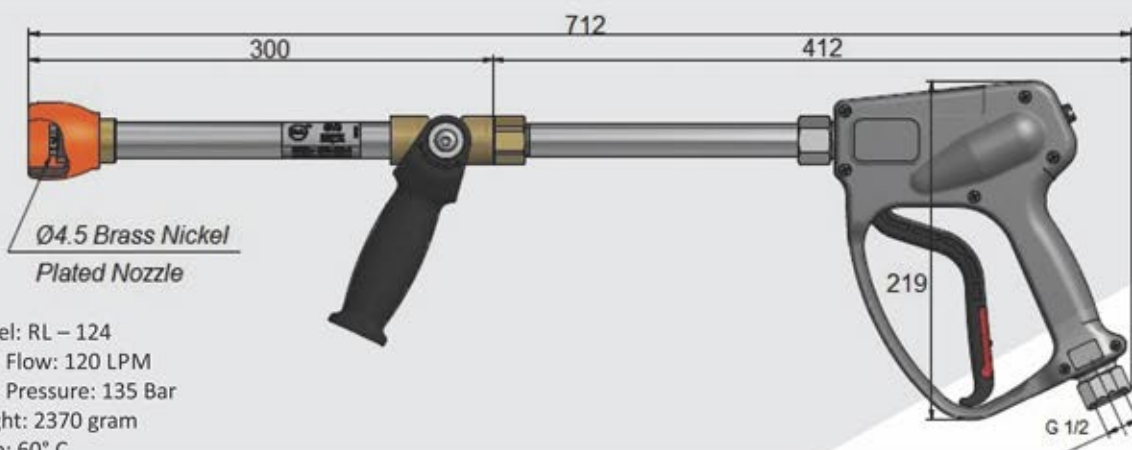

Model: RL – 124
 Max. Flow: 120 LPM
 Max. Pressure: 135 Bar
 Weight: 2370 gram
 Temp: 60° C

(All Dimensions are in MM)

Important Note : Owing to continuous R & D, any technical details & specifications mentioned in this catalogue are liable to change anytime. All rights reserved to PressureJet. For latest Information & more details, please visit our website. Our Website is fully informative, exhaustive and communicative. It is designed to provide maximum information in most precise form to help our valued customers to take a quick and right decision.

Contact :

PressureJet Systems Pvt. Ltd.

62/13, Phase-1, Vatva GIDC, Ahmedabad – 382 445, Gujarat, India.

Phone : +91-79-25830762/ 25835598 • M : 93750 22359 • E-mail : sales@pressurejet.com • URL : www.pressurejet.com