

Hydro Blasting Pumps & Systems

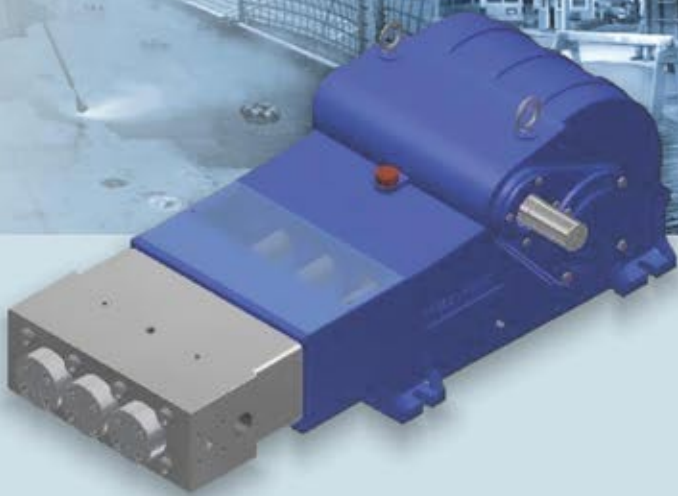

PressureJet[™]
EXPLORE THE WATER POWER

About Company

PressureJet Systems Pvt. Ltd. was established in 1996 in Ahmedabad, India. PressureJet (an ISO 9001:2008 certified company) is a leading manufacturer of High Pressure, Positive Displacement, Reciprocating Triplex Plunger Pumps, Systems and relevant accessories. These pumps are widely used for various applications like Granite & Marble Texturing, Wet Sand Blasting, Sewer Jetting, Hydro Blasting, Water Jet Cleaning, Hydro test, Descaling, Fire Fighting, Transfer & many more.

Today, PressureJet has a workforce of more than 70 dedicated people. We have 11000 Sq. ft. area in Asia's premier industrial estate in Ahmedabad. Out of which, 5000 Sq. ft. area has been allocated for manufacturing activities.



Our Quality

All components are quality checked in the controlled environment of the QC department. We have the most modern measurement equipment such as 3D CMM (Coordinate Measuring Machine), Surface Roughness Tester, Hardness Tester etc. All components are tracked by barcode system with oracle ERP.



3D modelling is an important aid in designing the technical aspects of engineering product. Simulation can really help in making the correct design decisions during the development stage.

At PressureJet, we are using all latest Design Softwares.

Machine Shop

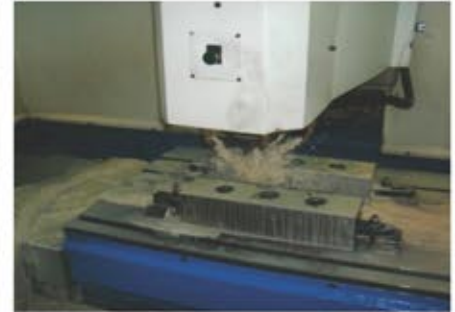

Our Ultra-modern machine shop enables us to manufacture an extremely wide range of components. We can be very flexible in our production planning, while maintaining a high standard of quality with fully automatic machining station. Computer controlled machining stations ensure constant dimensional accuracy.

Assembly & Testing



In this area, all components for the various pump units come together. Pumps and engine or motors are assembled on the skid frame, Accessories such as booster pump, Strainers, PRV, Safety Valve etc. are assembled.

PressureJet products are subject to stringent quality control. All pumps are tested at maximum load prior to dispatch for decided time period. All measurement taken during the testing are electronically stored in computer through fully Automatic Test Bench and then it can be printed. Test report is always provided with the pump.

Store / Service



A product is only as good as the service backing it. We have a dedicated team of technicians available for 24 X 7. We keep majority of spares Ex-stock to reduce down time.

Hydro Blasting Selection Graph

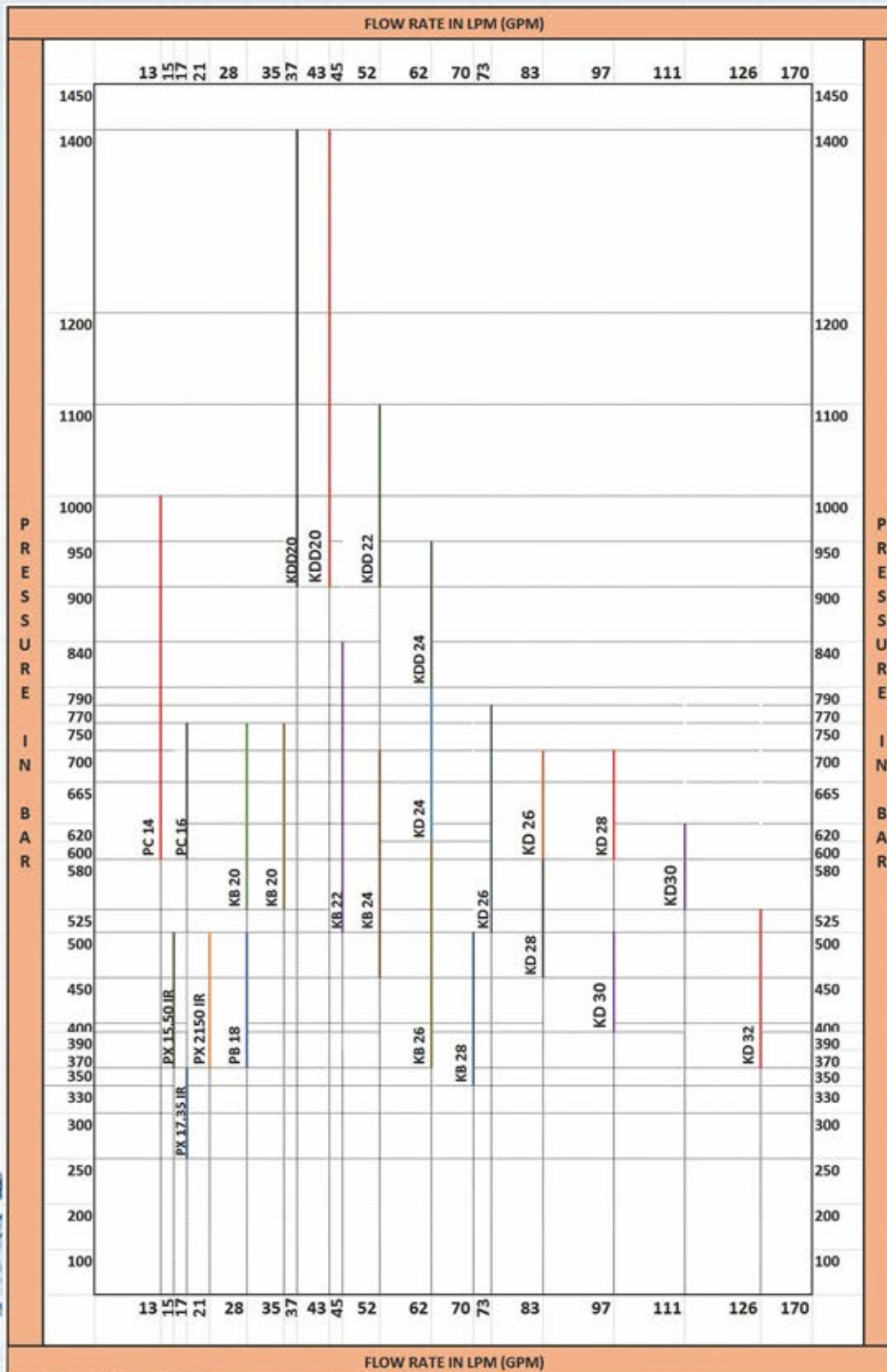

Hydro Blasting Selection Chart

Pump Selection Chart					
Pump Series	Model	Flow Rate in LPM (GPM)	Pressure in Bar (Required Motor HP)		
HW	PX 17.35 IR	17(4.5)	350 (15)		
	PX 15.50 IR	15(4.0)	500 (20)		
	PX 21.50 IR	21(5.5)	500 (30)		
P	PC 14	13(3.4)	1000 (40)	800 (30)	600 (25)
	PC 16	17(4.5)	750 (40)	600 (30)	
	PB 18	28 (7.39)	500 (40)		
KB	KB 20	28 (7.39)	750 (60)	620 (50)	
		35(9.25)	750 (75)	620 (60)	550 (50)
	KB 22	45(11.9)	840 (100)	620 (75)	500 (60)
	KB 24	52(13.7)	700 (100)	530 (75)	450 (60)
	KB 26	62(16.4)	600 (100)	450 (75)	370 (60)
	KB 28	70(18.5)	500 (100)	400 (75)	330 (60)
KD	KD 24	62(16.4)	790 (120)	655 (100)	450 (75)
	KD 26	73(19.3)	770 (150)	670 (120)	560 (100)
		83(21.9)	700 (150)		
	KD 28	84(22.2)	580 (120)	450 (100)	
		97(25.6)	700 (180)	600 (150)	
	KD 30	97(25.6)	500 (120)	390 (100)	
		111(29.3)	620 (180)	525 (150)	
KD 32	126(33.3)	525 (180)	450 (150)	350 (120)	
KDD	KDD 20	37 (9.77)	1400 (150)	1250 (120)	1000 (100)
		43(11.4)	1400(150)	1000 (120)	900 (100)
	KDD 22	52(13.7)	1100 (150)	900 (120)	
	KDD 24	62(16.4)	950 (150)		

Note : More than 80LPM Pumps are used for multigun external surface cleaning applications only and not for single gun applications.

HW Series



Bare Pump



Frame Mounted System



Trolley Mounted System

Specifications – HW Series

Sr. No.	Pump Model	Plunger Dia. (mm)	Stroke Length (mm)	Max. Thrust on Plunger (Kgs)	Inlet Connection Size (BSPF)	Outlet Connection Size (BSPF)	Required Suction Pressure	Oil Grade	Oil Capacity (Ltr)	Bare Pump Weight (Kg)
1	PX 15.50 IR		15	1272						
2	PX 17.35 IR	18	17	891	1/2"	3/8"	Flooded	SAE 10W-40	1.2	19.2
3	PX 21.50 IR		21	1272						

HW Series Model Selection Chart

Pump Model	Flow Rate in LPM (GPM)	Pressure in Bar (Required Motor HP)
PX 15.50 IR	15(4.0)	500 (20)
PX 17.35 IR	17(4.5)	350 (15)
PX 21.50 IR	21(5.5)	500 (30)

Note : (1) Flow rates indicated are at 100% volumetric efficiency. Actual flow rate will be $\geq 90\%$.

(2) All models are suitable for 50 Hz (1500RPM) and 60 Hz (1800 RPM) power specification.



Material of Construction of Major Internal Parts

- 1 Crank Case (Main Body) :**
Crank Case in High Strength Aluminum Pressure Die Casting. With fit led anti friction bush.
- 2 Crankshaft :**
Crankshaft is made of Forged Alloy Steel, with Hardened & Ground.
- 3 Bearing :**
Oversized for maximum life and load disbursement. Self-alignment roller bearing enables it to handle 26% more load than other pumps.
- 4 Connecting Rod :**
Forged Aluminum connecting rods with antifriction bearings. Heavy pin area construction, for added load strength.
- 5 Piston (Plunger Rod) :**
Stainless Steel Construction for hard surface coating and super finish.
- 6 Pump Head (Manifold Housing) :**
Pump head is made of High Strength Forged Brass.
- 7 Plunger :**
High Finish Solid Ceramic Plunger and Surface roughness is extremely good i.e. <0.25 Ra for less wear of Plunger seal.
- 8 Plunger Seal :**
Durable Fiber Impregnated Buna-n Seal packing (Make Parker, Germany) for high compressive & tensile strength ensures effective sealing.
- Complete Valve :**
- 9 Valves** made of Stainless Steel anti corrosion hard surface coated for long life. High volumetric efficiency, valves operate at more than 95% efficiency.

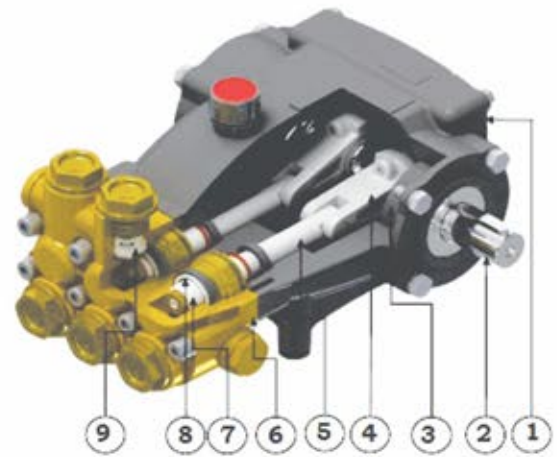

HW Series Bare Pump Dimensions (All Dimensions are in mm)

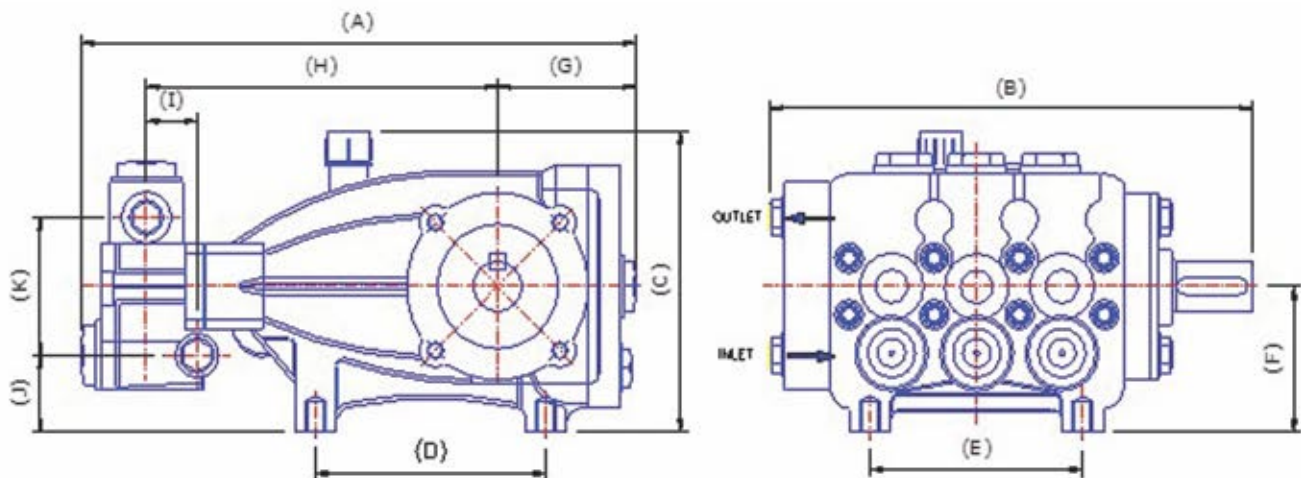

Model	A	B	C	D	E	F	G	H	I	J	K
PX 15.50 IR											
PX 17.35 IR	303.5	263	168.5	145	105	82	81.5	244.5	12	40	82
PX 21.50 IR											

P Series

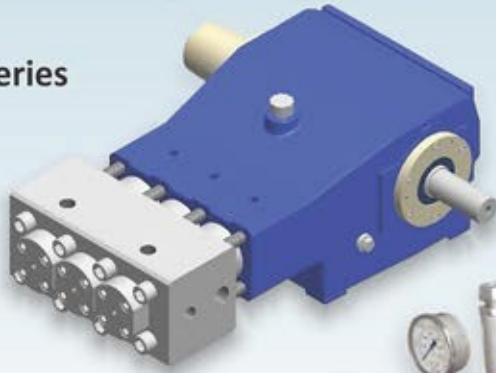

Bare Pump



Frame Mounted System



Trolley Mounted System

PB Bare Pump - Dimension

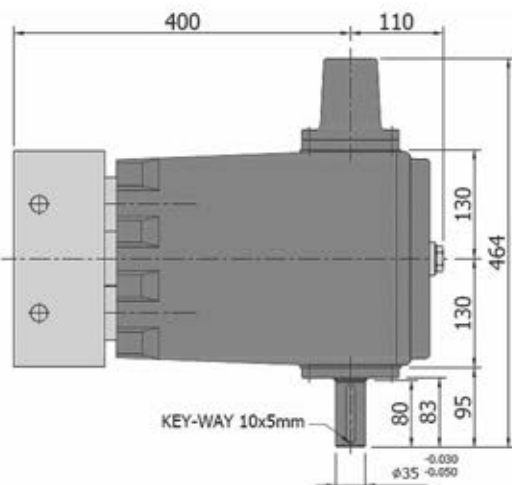
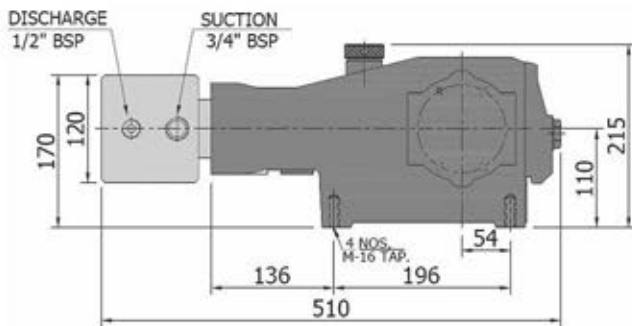
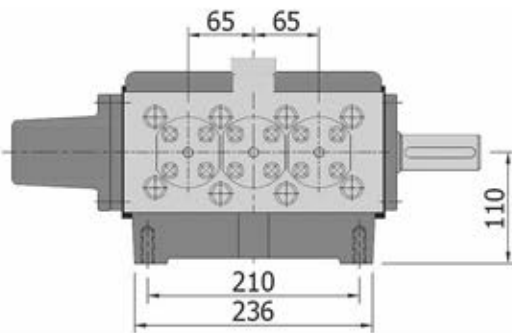

Specification

- Plunger Stroke: 40 mm
- Max. plunger speed: 1.26 m/sec. @ 950 spm
- Plunger force: 12.5 kN (1274 kgf)
- Inlet Pressure min./max.: 2-3 bar (Booster Pump flow require min. 1.5 times of rating flow)
- Oil Type: 15W 40, Oil capacity: 5 ltr.
- Max. Liquid Temp.: 70 °C (160°F)
- Discharge Connection: 1/2" BSPF
- Suction Connection: 3/4" BSPF
- Medium: Clean water
- Splash lubrication.
- Available direct couple 1000 rpm for 50Hz (Not 60Hz) or pulley – belts drives or gear box.

P Series Model Selection Chart

Pump Model	Flow Rate in LPM (GPM)	Pressure in Bar (Required Motor HP)		
		1000 (40)	800 (30)	600 (25)
PC 14	13(3.4)	1000 (40)	800 (30)	600 (25)
PC 16	17(4.5)	750 (40)	600 (30)	
PB 18	28(7.39)	500 (40)		

Note : (1) Flow rates indicated are at 100% volumetric efficiency. Actual flow rate will be $\geq 90\%$.
(2) All models are suitable for 50 Hz (1500RPM) and 60 Hz (1800 RPM) power specification.

Material of Construction of Major Internal Parts

Power End

- 1 **Main Body (Crank Case) :**
Grey Cast Iron : Main body in grey iron casting FG-260. With Honned surface finish bore.
- 2 **Crankshaft :**
Spheroidal Graphite Iron : Crankshaft is made of nitrated, hardened and tempered Spheroidal Graphite Iron casting.
- 3 **Connecting Rod :**
Alloy Steel : Forged steel connecting rods with antifriction bearings. Heavy pin area construction, for added load strength.
- 4 **Piston (Cross Head) :**
Alloy Steel : Alloy steel construction for hard surface coating and super finish.
- 5 **Bearing :**
Oversized for maximum life and load disbursement. Self-alignment roller bearing enables it to handle 26% more load than other pumps.

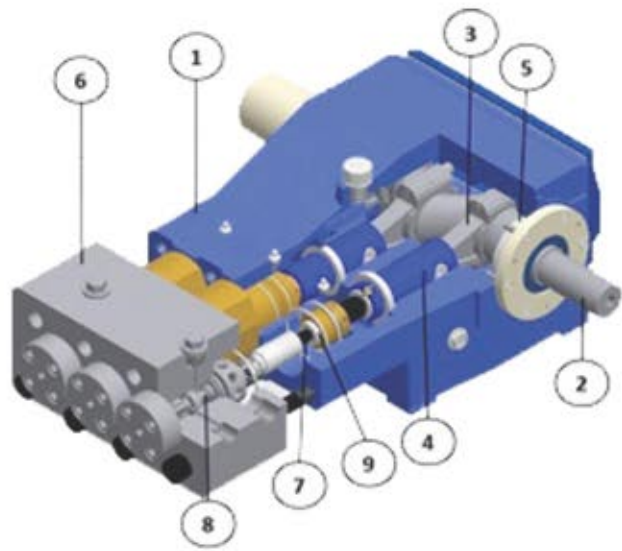

PC Bare Pump - Dimension

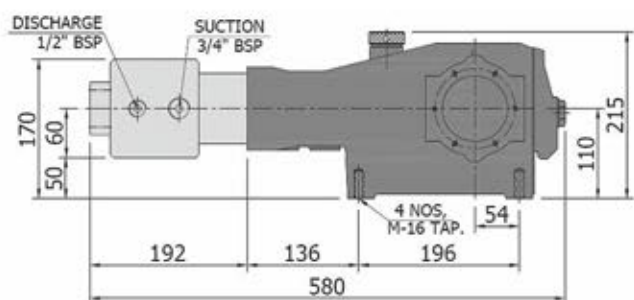
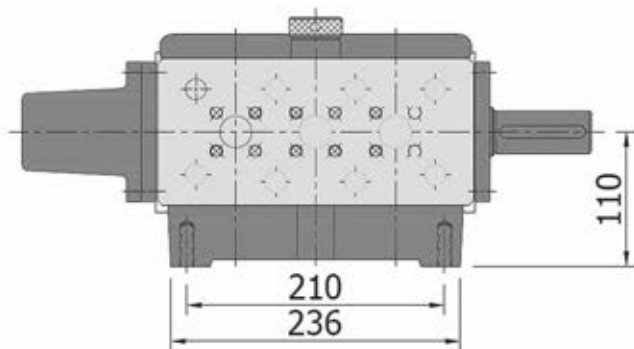

Fluid End

- 6 **Pump Head :**
Stainless Steel : Liquid end is made of high corrosion resistant forged SS304.
- 7 **Plunger (Ceramic / Tungsten coated) :**
Primarily composed of ceramic coated or Tungsten coated. Surface roughness is extremely good i.e. <0.2 Ra.
- 8 **Complete Valve :**
Stainless Steel : Valves made stainless steel for hardened & anti corrosion hard surface coated for long life. High volumetric efficiency valves operate at 95% efficiency plus.
- 9 **Plunger Seal :**
PTFE Aramide : "V" style strong and tightens under load or Aramide fiber yarn packing for high compressive & tensile strength ensure effective sealing.

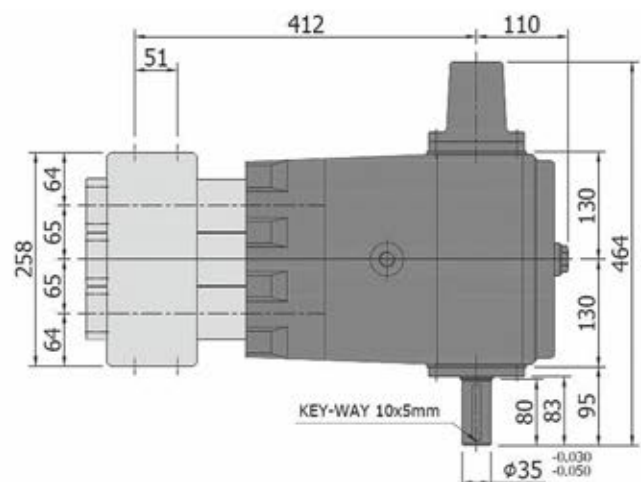

KB Series

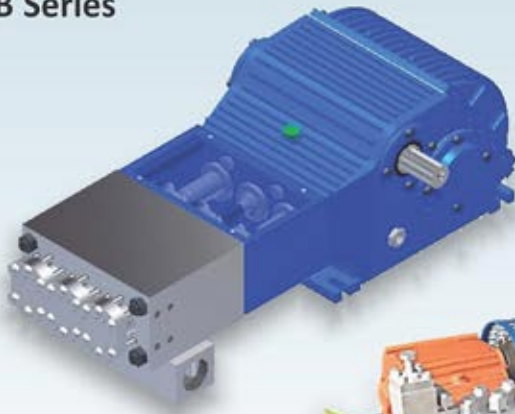

Bare Pump



Frame Mounted System



Trolley Mounted System

Specification

- Plunger Stroke: 75 mm
- Max. plunger speed: 1.32 m/sec. @ 530 spm
- Plunger force: 31.28 kN (3190 kgf)
- Inlet Pressure min./max.: 2-3 bar
(Booster Pump flow require min. 1.5 times of rating flow)
- Oil Type: 80W 90
- Oil capacity: 8 ltr.
- Max. Liquid Temp.: 70 °C (160°F)
- Discharge Connection: Ø G Hole (as per drawing)
- Suction Connection: 2" BSPF
- KB Series Designed in built gear.
- Splash lubrication/ forced feed lubrication

Note : (1) Flow rates indicated are at 100% volumetric efficiency. Actual flow rate will be $\geq 90\%$.

(2) All models are suitable for 50 Hz (1500RPM) and 60 Hz (1800 RPM) power specification.

KB Series Model Selection Chart

Pump Model	Flow Rate in LPM (GPM)	Pressure in Bar (Required Motor HP)		
		750 (60)	620 (50)	550 (50)
KB 20	28 (7.39)	750 (60)	620 (50)	
	35 (9.25)	750 (75)	620 (60)	550 (50)
KB 22	45 (11.9)	840 (100)	620 (75)	500 (60)
KB 24	52 (13.7)	700 (100)	530 (75)	450 (60)
KB 26	62 (16.4)	600 (100)	450 (75)	370 (60)
KB 28	70 (18.5)	500 (100)	400 (75)	330 (60)



Material of Construction of Major Internal Parts

Power End

- 1 **Main Body (Crank Case)**
Spheroidal Graphite: Main body in spheroidal graphite Iron casting with honned surface finish bore.
- 2 **Crankshaft**
Alloy steel: Crankshaft is made of nitrated, hardened and precision ground for extremely long life and durability.
- 3 **Connecting Rod**
Alloy Steel: Forged steel connecting rods with antifriction bearings. Heavy pin area construction, for added load strength.
- 4 **Piston (Cross Head)**
Grey Iron & Stainless Steel: Alloy steel casting piston & stainless steel piston rod are hardened & super finish surface.
- 5 **Pinion Shaft**
Alloy steel: Pinion shaft is nitride hardened and precision ground for extremely long life and durability.
- 6 **Helical Gear**
Alloy steel: Helical gear is nitride hardened and precision ground for extremely long life and durability.
- 7 **Bearing**
Oversized for maximum life and load disbursement. Self-alignment roller bearing enables it to handle 26% more load than other pumps.
- 8 **White Metal Bearing**
Antifriction bearings for long life of crankshaft

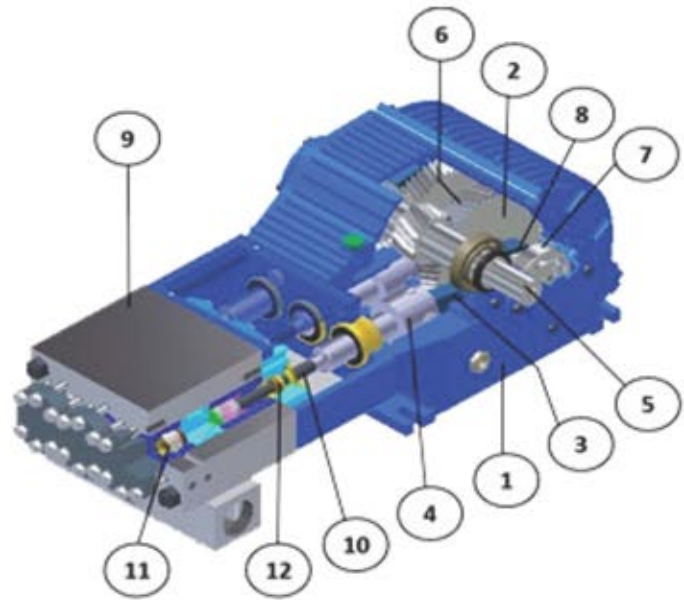

Fluid End

- 9 **Pump Head**
Stainless Steel: Liquid end is made of high corrosion resistant. Forged stainless steel.
- 10 **Plunger (Ceramic / Tungsten coated)**
Primarily composed of ceramic coated or Tungsten coated. Surface roughness is extremely good i.e. <0.2 Ra.
- 11 **Complete Valve**
Stainless Steel: Valves made stainless steel for hardened & anti corrosion hard surface coated for long life. High volumetric efficiency valves operate at 95% efficiency plus.
- 12 **Plunger Seal**
PTFE Aramide: Aramide fibre yarn packing with PTFE fibre face or carbonaceous aramide yarn packing with GFO fibre face for high compressive & tensile strength ensure effective sealing.

KB Bare Pump - Dimension

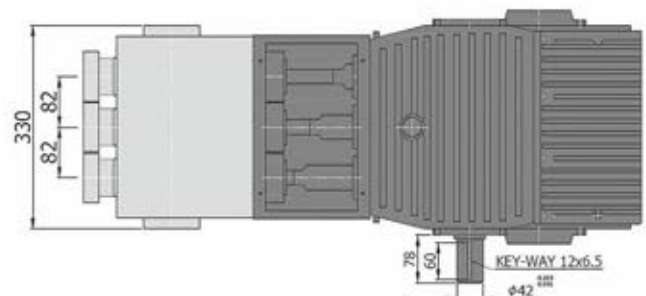
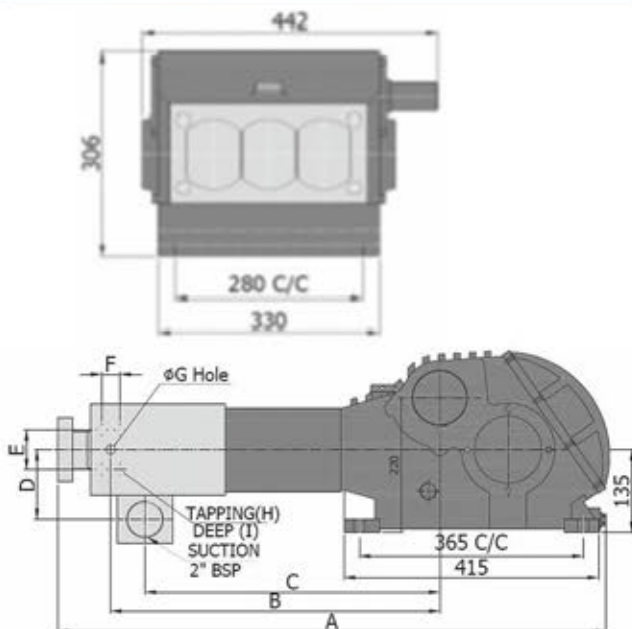

Dimensions	A	B	C	D	E	F	G	H	I
KB 20									
KB 22	895	537	481	114	65	30	∅ 15	M - 14	30
KB 24									
KB 26	802	397.5	485	204	30	65	∅ 20	M - 14	30
KB 28									

KD Series

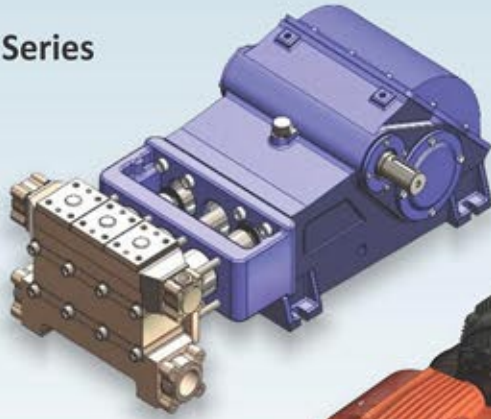

Bare Pump



Frame Mounted System



Trolley Mounted System

Type of systems – Complete systems available various type

- Stationary unit with diesel engine
- Stationary unit with electric motor
- Mobile unit with electric motor
- Mobile unit with diesel engine
- Road going trailer with electric motor
- All unit available in 4 side cover or canopy on request

Specification

- Plunger Stroke: 105 mm
- Max. plunger speed: 1.52 m/sec. @ 500 spm
- Plunger force: 40 kN (4080 kgf)
- Inlet Pressure min./max.: 2-3 bar
- Oil Type: SAE – 80 W 90
- Oil capacity: 8 ltr.
- Max. Liquid Temp.: 70 °C (160 °F)
- Discharge Connection: ⌀ G Hole (as per drawing)
- Suction Connection: 3" BSPF
- Dimensions: 1044x531x365 (lxbxh) in mm

KD Series Model Selection Chart

Pump Model	Flow Rate in LPM (GPM)	Pressure in Bar (Required Motor HP)		
KD 24	62(16.4)	790 (120)	655 (100)	450 (75)
KD 26	73(19.3)	770 (150)	670 (120)	560 (100)
	83(21.9)	700 (150)		
KD 28	84(22.2)	580 (120)	450 (100)	
	97(25.6)	700 (180)	600 (150)	
KD 30	97(25.6)	500 (120)	390 (100)	
	111(29.3)	620 (180)	525 (150)	
KD 32	126(33.3)	525 (180)	450 (150)	350 (120)



Note : (1) Flow rates indicated are at 100% volumetric efficiency. Actual flow rate will be ≥ 90%.
(2) All models are suitable for 50 Hz (1500RPM) and 60 Hz (1800 RPM) power specification.

Material of Construction of Major Internal Parts

Power End

- 1 **Crank Case (Main Body)**
Spheroidal Graphite Iron : Main body in spheroidal graphite Iron casting with honned surface finish bore.
- 2 **Crankshaft**
Alloy steel : Crankshaft is made of nitrated, hardened and precision ground for extremely long life and durability.
- 3 **Connecting Rod**
Alloy Steel : Forged steel connecting rods with antifriction bearings. Heavy pin area construction, for added load strength.
- 4 **Piston (Cross Head)**
Grey Iron & Stainless Steel : Alloy steel casting piston & stainless steel piston rod are hardened & super finish surface.
- 5 **Pinion Shaft**
Alloy steel : Pinion shaft is nitride hardened and precision ground for extremely long life and durability.
- 6 **Helical Gear**
Alloy steel : Helical gear is nitride hardened and precision ground for extremely long life and durability.
- 7 **Bearing**
Oversized for maximum life and load disbursement. Self-alignment roller bearing enables it to handle 26% more load than other pumps.
- 8 **White Metal Bearing**
Antifriction bearings for long life of crankshaft

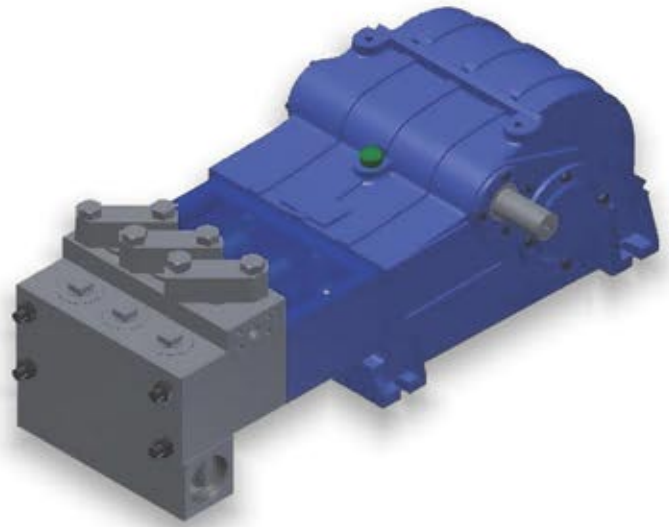

KD Bare Pump - Dimension

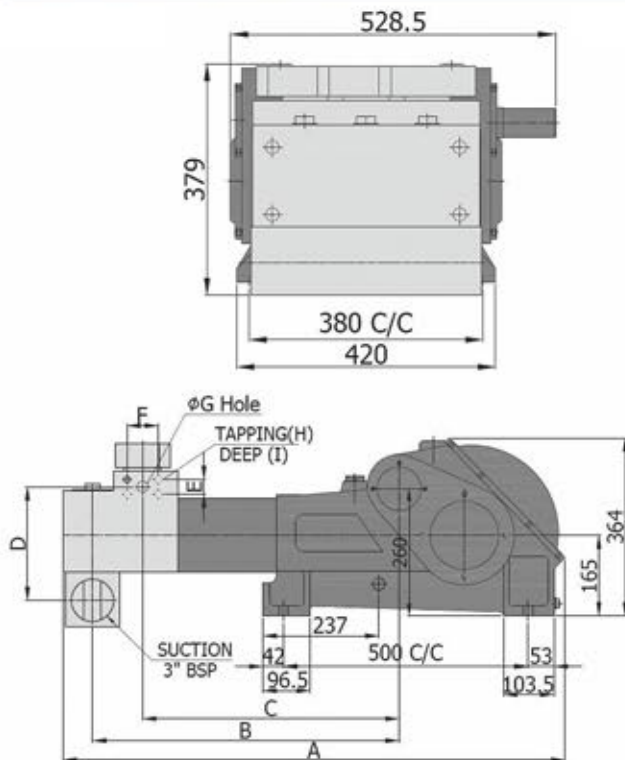

Fluid End

- 9 **Pump Head**
Stainless Steel : Liquid end is made of high corrosion resistant. Forged stainless steel.
- 10 **Plunger (Ceramic / Tungsten coated)**
Primarily composed of ceramic coated or Tungsten coated. Surface roughness is extremely good i.e. <0.2 Ra.
- 11 **Complete Valve**
Stainless Steel : Valves made stainless steel for hardened & anti corrosion hard surface coated for long life. High volumetric efficiency valves operate at 95% efficiency plus.
- 12 **Plunger Seal**
PTFE Aramide : Aramide fibre yarn packing with PTFE fibre face or carbonaceous aramide yarn packing with GFO fibre face for high compressive & tensile strength ensure effective sealing.

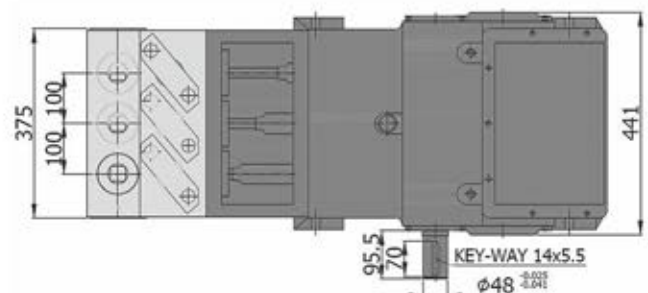

Dimensions	A	B	C	D	E	F	G	H	I
Valve	1026	627	524	232.5	30	64	Ø 22	M - 14	30

KDD Series



Bare Pump



Pic. with Ele. Motor on Trolley



Trolley Mounted System

Type of systems – Complete systems available various type

- Stationary unit with diesel engine
- Stationary unit with electric motor
- Mobile unit with electric motor
- Mobile unit with diesel engine
- Road going trailer with electric motor
- All unit available in 4 side cover or canopy on request

Specification

- Plunger Stroke: 95 mm
- Max. plunger speed: 1.58 m/sec. @ 500 spm
- Plunger force: 43 kN (4385 kgf)
- Inlet Pressure min./max.: 2-3 bar (Booster Pump flow require min. 1.5 times of rating flow)
- Oil Type: 80W 90, Oil capacity: 11 Ltr.
- Max. Liquid Temp.: 70 °C (160 °F)
- Discharge Connection: Ø 16 Hole (as per drawing)
- Suction Connection: 1 1/2" BSPF
- In -built Gear box.
- In line Suction / delivery Valve.
- Splash lubrication and also available force feed lubrication with oil cooler / filter on request.

KDD Series Model Selection Chart

Pump Model	Flow Rate in LPM (GPM)	Pressure in Bar (Required Motor HP)		
KDD 20	37 (9.77)	1400 (150)	1250 (120)	1000 (100)
	43 (11.4)	1400 (150)	1000 (120)	900 (100)
KDD 22	52 (13.7)	1100 (150)	900 (120)	
KDD 24	62 (16.4)	950 (150)		

Note : (1) Flow rates indicated are at 100% volumetric efficiency. Actual flow rate will be $\geq 90\%$.

(2) All models are suitable for 50 Hz (1500RPM) and 60 Hz (1800 RPM) power specification.



Material of Construction of Major Internal Parts

Power End

- 1 **Main Body (Crank Case)**
Spheroidal Graphite Iron : Main body in spheroidal graphite Iron casting with honned surface finish bore.
- 2 **Crankshaft**
Alloy steel : Crankshaft is made of nitrated, hardened and precision ground for extremely long life and durability.
- 3 **Connecting Rod**
Alloy Steel : Forged steel connecting rods with antifriction bearings. Heavy pin area construction, for added load strength.
- 4 **Piston (Cross Head)**
Grey Iron & Stainless Steel : Alloy steel casting piston & stainless steel piston rod are hardened & super finish surface.
- 5 **Pinion Shaft**
Alloy steel : Pinion shaft is nitride hardened and precision ground for extremely long life and durability.
- 6 **Helical Gear**
Alloy steel : Helical gear is nitride hardened and precision ground for extremely long life and durability.
- 7 **Bearing**
Oversized for maximum life and load disbursement. Self-alignment roller bearing enables it to handle 26% more load than other pumps.
- 8 **White Metal Bearing**
Antifriction bearings for long life of crankshaft.

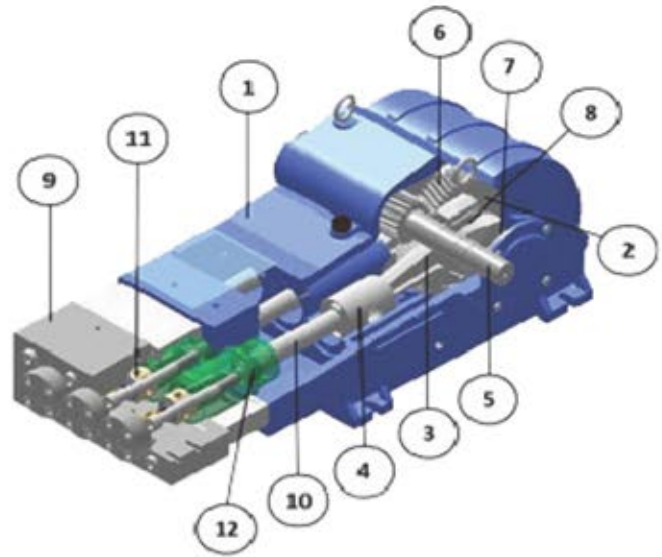

Fluid End

- 9 **Pump Head**
Stainless Steel : Liquid end is made of high corrosion resistant. Forged stainless steel.
- 10 **Plunger (Ceramic coated / Solid Ceramic)**
Primarily composed of Ceramic Coated or solid ceramic for long life of seal. Surface roughness is extremely good i.e. <0.2 Ra.
- 11 **Complete Valve**
Stainless Steel : Valves made stainless steel for hardened & anti corrosion hard surface coated for long life. High volumetric efficiency valves operate at 95% efficiency plus.
- 12 **Plunger Seal**
Special PTFE : High pressure seal & NBR low pressure sealing with cooling systems.

KDD Bare Pump - Dimension

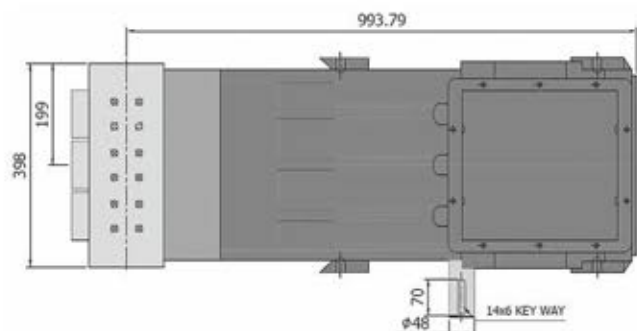
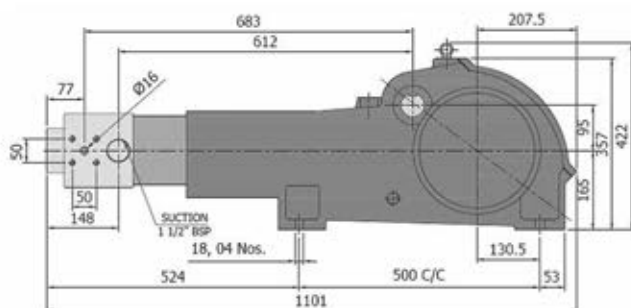
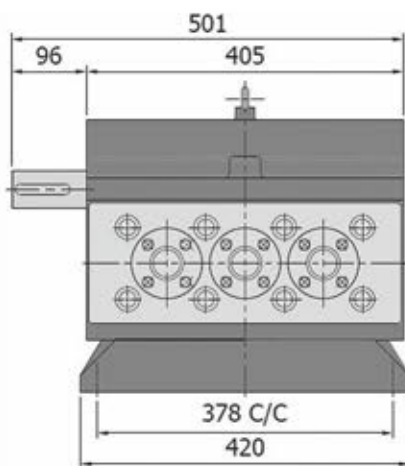

Various Types of Systems Applications



External Tube Bundle Cleaning



Internal Tube Cleaning



Ship Hull Cleaning



Concrete Removal



Vessel Cleaning



Surface Preparation



Tube Cleaning - Internal



Tube Bundle Cleaning

Accessories



Pressure Regulating Valve



Safety Valve



Trigger Operated Dump Gun

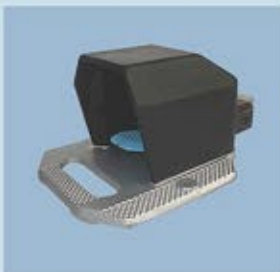

Foot Operated Dump valve



Barracuda-Nozzle



High Pressure Hose



High Pressure Flexible Lance

Contact :

PressureJet Systems Pvt. Ltd.

62/13, Phase-1, Vatva GIDC, Ahmedabad – 382 445. Gujarat, India

Phone : +91-79-25830762 / 25835598 • M : 93750 22359 • E-mail : sales@pressurejet.com • URL : www.pressurejet.com