

Kubota®

www.kubota.co.jp

Copyright © 2011–2013 by Kubota Corporation. All rights reserved

DC-68G
HARVESTING

ILLUSTRATED PARTS LIST

KUBOTA

MODEL DC-68G HARVESTING

COMBINE

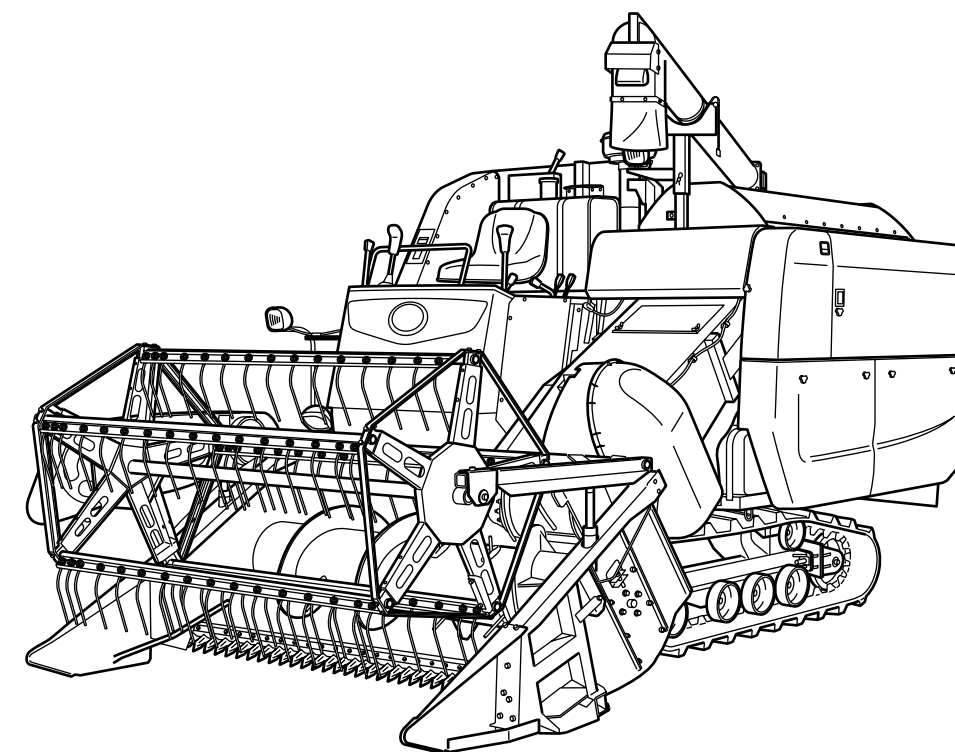

Kubota

97899-52030

AUG. 2013

NOTICE

This Parts List is for the following purposes.

1. When ordering parts, check with this Parts List to confirm the part number and the name of parts.
2. When making repairs, refer to the illustrations in this Parts List.
3. This Parts List is subject to change without notice.

KALPIS.No.		CFK1000017
BLOCK No.	LINE No.	A(1)
01	01 (ENG.)	1J881-15000 V2403-M-DI-TE-CS3T
	02	5T111-00000 DC-68G HARVESKING

DESIGN CHANGE No.
1G700-1811
5T111-0108

340·YF×KSI·0·KSI PRINTED in JAPAN

INSTRUCTIONS

①
010200 PISTON AND CRANKSHAFT

②
{B}

⑩ → S.No. ; A: ≤15000, B: 14000 to 15000

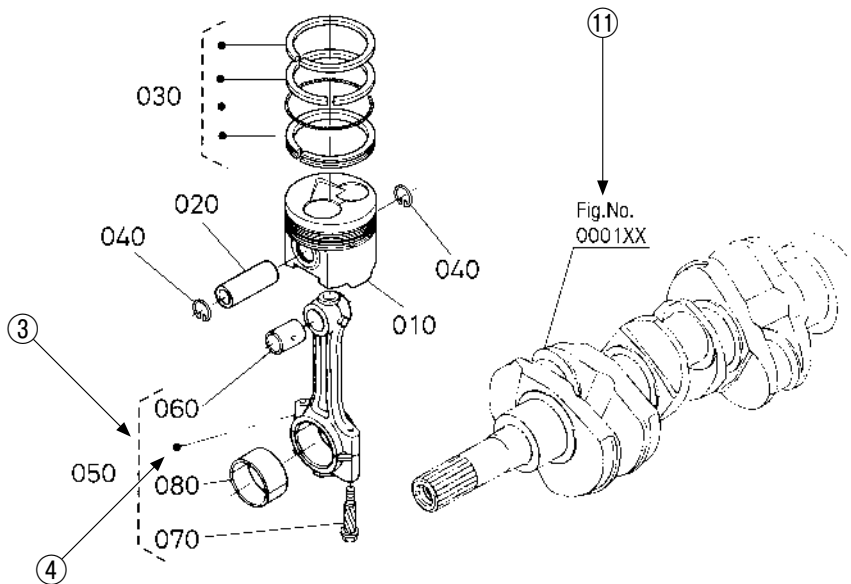

REF.No.	PART No.	PART NAME	Q'TY / S.No.		I.C.	REMARKS
			A	B		
010	15800-0000-0	PISTON	1 ≤15000	1 ≤15000		← (Example-1)
010	15800-0000-2	PISTON	1 ≥15001	1 ≥15001		←
020	15800-1000-0	PIN, PISTON	1 ≤15000	1 ≤15000		
020	15800-1000-2	PIN, PISTON	1 ≥15001	1 ≥15001	≠	← (Example-2)
030	15800-2000-0	ASSY PISTON RING	1 ≤15000	1 ≤15000		
030	15830-2000-0	ASSY PISTON RING	1 ≥15001	1 ≥15001	↔	← (Example-3)

- ① Fig. No. Represents No. corresponding to each group name.
- ② Specifications The types and destinations of sister models are indicated. These indications are given to (for sister models) tell their relevant pages in this book.
- ③ Components The components of an assembly are identified by a bracket of dotted lines.
- ④ Point Indicates that the parts is not sold independently.
The assembly (Ref.No.050) containing the part needs to be ordered.
- ⑤ REF. No. Reference numbers are assigned to parts in the illustration. The code number of a part in the illustration can be identified by referring to the same reference number in the parts list.
- ⑥ Model name The name of the basic model is indicated in this column. Other applicable models are indicated on the "REMARKS" column ⑨.
- ⑦ S. No. Indicates a group of serial numbers to which a design change is applied.
(serial No.)

Engine Serial No.

8 7 J 0001

8 7 K A001

Lower 4 digits in Numerals or Alphabetical letter (A to Z) and Numerals (start 0001 to max Z999).

5th digit Alphabetical letter (Month of manufacture).

Month	1	2	3	4	5	6	7	8	9	10	11	12
	A,B	C,D	E,F	G,H	J,K	L,M	N,P	Q,R	S,T	U,V	W,X	Y,Z

6th digit Numerals or Alphabetical letter (Year of manufacture).

Year	1998	1999	2000	01	02	03	04	05	06	07	08	09	10	11
	W	X	Y	1	2	3	4	5	6	7	8	9	A	B
Year	12	13	14	15	16	17	18	19	20	21	22	23	24	25
	C	D	E	F	G	H	J	K	L	M	N	P	R	S

7th digit Numerals or Alphabetical letter (The factory line identifying).

Identifying	1	2	3	4	5	6	7	8	A	B
-------------	---	---	---	---	---	---	---	---	---	---

- ⑧ I. C. Indicates the interchangeability of parts due to design change.
(interchangeability)
Example-1 ← indicates that a new part can replace an old part, but not vice versa.
15800-0000-0 is applicable to the first serial number to S. No. 15000.
15800-0000-2 is applicable to the first serial number and above.
Example-2 ≠ indicates that the new and old parts are not interchangeable.
15800-1000-0 is applicable to the first serial number to S. No. 15000.
15800-1000-2 is applicable to S. No. 15001 and above.
Example-3 ↔ indicates that the new and old parts are interchangeable. Both 15800-2000-0 and 15830-2000-0 are applicable to the first serial number and above.
- ⑨ REMARKS 1 In this column, enter other applicable model names, dimensions and other special items.
The following symbols and abbreviations are used throughout this book.
29* 12.00-15 ... Tire size sq.m ... m² sq.mm ... mm²
cu.m ... m³ cu.mm ... mm³ D ... Diameter L ... Length
W/G No. ... Whole goods number.
STD ... Standard / SET ... Set sale / T ... Teeth
OLD ... Old parts, old shapes or old models
NEW ... New parts, new shapes or new models
Y ... RAPESEED TYPE

- ⑩ REMARKS 2 The following expressions are used in NOTE for each group.
Machines' serial numbers are indicated as follows.
<=15000 Serial number below 15000.
>=15001 Serial number above 15001.
14000 to 15000 Serial number 14000 to 15000.
For some models, the above expressions may also be used REMARKS 1 ⑨.
- ⑪ Fig. No. Indicates the numbers of figures for the parts that are shown in virtual images.
(virtual images) A figure numbers with XX means that there are two or more figures depending on the sister models or the production lots.

SERIAL NUMBER

The model name, machine number and engine number of this product are described in their respective positions, as shown below. Note that their positions may be different depending on the specifications.

Check the specifications of the product.

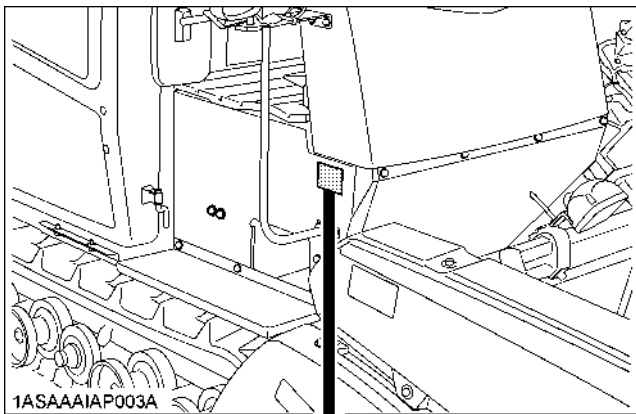

MAKE	KUBOTA
MODEL	DC-68G HARVESKING
SERIAL NO.	
ENGINE	V2403-M-DI-TE-CS3T
SERIAL NO.	
OUTPUT/SPEED	49.2 (67) KW (PS) /2700rpm
○ KUBOTA Corporation ○	

1ASAAARAP036A

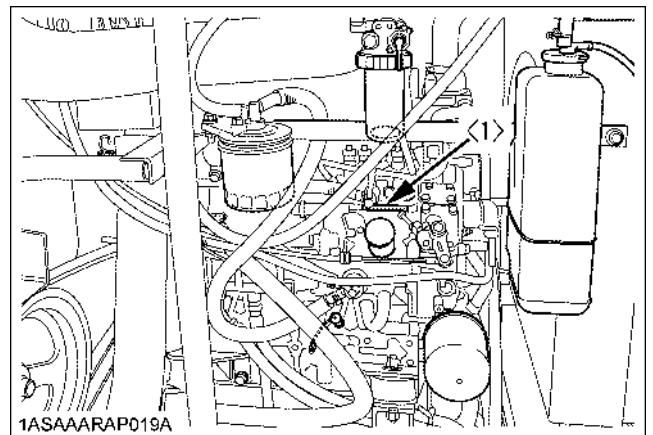

(1) Engine serial number

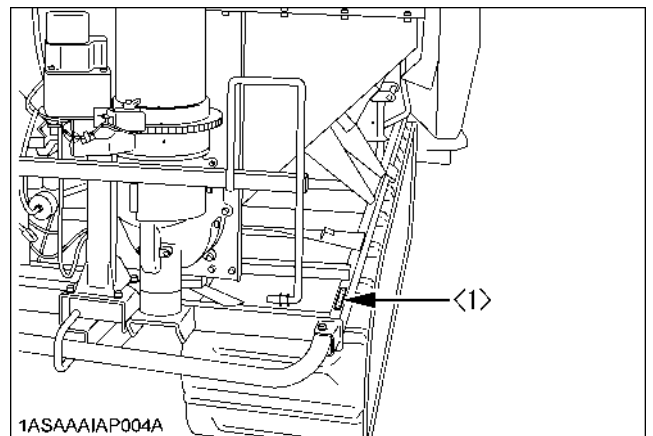

(1) Combine serial number

CONTENTS

[V2403-M-DI-TE-CS3T]	522800	BODY RELAY/HORN/SENSOR.....	45
000100	CRANKCASE	1	
000200	OIL PAN	2	
000300	CYLINDER HEAD	3	
000400	GEAR CASE	4	
000500	HEAD COVER.....	5	
000600	OIL FILTER	6	
000700	DIPSTICK AND GUIDE	7	
000800	OIL PUMP	8	
010000	MAIN BEARING CASE	9	
010100	CAMSHAFT AND IDLE GEAR SHAFT	10	
010200	PISTON AND CRANKSHAFT	11	
010300	FLYWHEEL	13	
010500	FUEL CAMSHAFT AND GOVERNOR SHAFT.....	14	
020000	IDLE APPARATUS.....	15	
020200	INJECTION PUMP	16	
020500	SPEED CONTROL PLATE	17	
020601	NOZZLE HOLDER	18	
020602	OVER FLOW PIPE.....	19	
021200	FORK LEVER(GOVERNOR)	20	
050000	WATER FLANGE AND THERMOSTAT.....	21	
050100	WATER PUMP	22	
050400	COOLER FAN	23	
060000	VALVE AND ROCKER ARM	24	
060100	INLET MANIFOLD.....	25	
060200	EXHAUST MANIFOLD	26	
[DC-68G HARVESKING]			
061200	MUFFLER	27	
[V2403-M-DI-TE-CS3T]			
061600	TURBO CHARGER.....	28	
[DC-68G HARVESKING]			
061800	AIR CLEANER.....	29	
061900	PRE-CLEANER	30	
[V2403-M-DI-TE-CS3T]			
062000	OIL PIPE (TURBO CHARGER)	31	
070200	OIL COOLER	32	
[DC-68G HARVESKING]			
130400	FUEL TANK.....	33	
132500	FUEL PIPE AND FUEL FILTER.....	34	
132600	FUEL FILTER [COMPONENT PARTS].....	35	
133000	SEPARATOR [COMPONENT PARTS].....	36	
150200	RADIATOR	37	
150300	WATER PIPE	38	
150500	RESERVE TANK.....	39	
501000	ALTERNATOR	40	
502000	ALTERNATOR [COMPONENT PARTS].....	41	
505000	STARTER.....	42	
506000	STARTER [COMPONENT PARTS]	43	
511000	BATTERY	44	
	523000	COCKPIT SWITCH	46
	531000	FRONT PANEL	47
	[DC-68G HARVESKING-THRESHING]		
	531400	SWITCH/SENSOR(THRESHING).....	48
	[DC-68G HARVESKING-GRAIN TANK]		
	531801	SWITCH(GRAIN TANK).....	49
	531802	RELAY/BACK BUZZER(GRAIN TANK).....	50
	531900	UNLOADER MOTOR	51
	[DC-68G HARVESKING]		
	541001	WORK LIGHT(BODY).....	52
	[DC-68G HARVESKING-REEL/FEEDER]		
	541002	WORK LIGHT(HARVEST)	53
	[DC-68G HARVESKING-THRESHING]		
	541003	WORK LIGHT(THRESHING)	54
	[DC-68G HARVESKING-GRAIN TANK]		
	541004	WORK LIGHT (GRAIN TANK)	55
	[DC-68G HARVESKING]		
	571000	WIRE HARNESS(BODY).....	56
	[DC-68G HARVESKING-REEL/FEEDER]		
	571700	WIRE HARNESS(HARVEST)	57
	[DC-68G HARVESKING-THRESHING]		
	572000	WIRE HARNESS(THRESHING).....	58
	[DC-68G HARVESKING-GRAIN TANK]		
	573000	WIRE HARNESS (GRAIN TANK)	59
	[DC-68G HARVESKING]		
	A40000	MAIN FRAME	60
	A40500	ENGINE BASE	61
	A40800	DECK	62
	A50000	OPERATION FRAME	63
	A50400	OPERATION PANEL.....	64
	A50800	SEAT	65
	A50900	TOOL BOX	67
	A51000	DUSTPROOF COVER 1	68
	A51100	DUSTPROOF COVER 2	69
	A51500	CANOPY	70
	A60000	COUNTER PULLEY.....	71
	A60500	TENSION(TRAVEL)	72
	B30000	TRANSMISSION CASE	73
	B31000	HST	74
	B31100	HST [COMPONENT PARTS] 1.....	75
	B31200	HST [COMPONENT PARTS] 2.....	76
	B31300	HST [COMPONENT PARTS] 3.....	77
	B31400	HST [COMPONENT PARTS] 4.....	78
	B31500	HST [COMPONENT PARTS] 5.....	79
	B31800	HST INPUT SHAFT.....	80
	B32000	TRANSMISSION CASE INSIDE 1	81
	B32400	TRANSMISSION CASE INSIDE 2	82
	B32800	TRANSMISSION CASE INSIDE 3	83
	B33000	TRANSMISSION CASE INSIDE 4	84

CONTENTS

B33200 BRAKE	85	F51000 HARVEST FRAME COVER	127
C10000 CRAWLER	86	F51500 REEL CENTER SHAFT	128
C10101 TRACK ROLLER LH	87	F52000 REEL ADJUSTMENT	129
C10102 TRACK ROLLER RH	88	F52500 TINE	130
C10301 TENSION FRAME LH	89	F53000 BLADE REAPING	131
C10302 TENSION FRAME RH	90	F53500 TENSION ARM	132
C10401 CRAWLER GUIDE LH	91	F54000 AUGER DRUM	133
C10402 CRAWLER GUIDE RH	92	F54500 AUGER DRUM SHAFT	135
C10501 DRIVE ROLLER LH	93	F55000 AUGER DRUM CHAIN	136
C10502 DRIVE ROLLER RH	94	F55500 FINGER SHAFT	138
D70000 HYDRAULIC TANK	95	F56000 DIVIDER LH	139
D70500 HYDRAULIC PUMP	96	F56500 DIVIDER RH	140
D70600 HYDRAULIC PUMP [COMPONENT PARTS]	97	F57000 BLADE REAPING DRIVE ARM	141
D70700 OIL DRAIN HOSE	98	F57500 BLADE REAPING DRIVE SHAFT	142
D71000 HYDRAULIC HOSE 1	99	F58000 HARVEST DRIVE SHAFT	143
D71100 HYDRAULIC HOSE 2	100	F58500 FEEDER FRAME	144
D71200 HYDRAULIC HOSE 3	101	F59000 FEEDER COVER	145
D71600 HYDRAULIC HOSE 4	102	F59500 FEEDER FAN COVER	146
D72000 REEL ELEVATOR CYLINDER	103	F60000 FEEDER DRUM	147
D72100 REEL ELEVATOR CYLINDER [COMPONENT PARTS]	104	F60500 FEEDER DRIVE CHAIN	148
D72300 HYDRAULIC UNIT (MISSION)	105	F61000 HARVEST DRIVE CHAIN	149
D72400 HYDRAULIC UNIT (MISSION) [COMPONENT PARTS]	106	F61500 FEEDER DRIVE SHAFT	150
D72800 CLUTCH CYLINDER	107	[DC-68G HARVESKING-THRESHING]	
D72900 CLUTCH CYLINDER [COMPONENT PARTS]	108	F62000 HARVEST TENSION ARM	151
D73000 HYDRAULIC UNIT(HARVEST)	109	F62500 HARVEST REVERSAL LEVER	152
D73100 HYDRAULIC UNIT (HARVEST) [COMPONENT PARTS]	110	H00101 THRESHING FRAME(UPPER)	153
D73500 HARVEST CYLINDER	111	H00102 THRESHING FRAME(LOWER)	154
D73600 HARVEST CYLINDER [COMPONENT PARTS]	112	H01000 WINNOWER PLATE	155
D73800 UNLOADER CYLINDER	113	H01100 WIND DIRECTION PLATE	156
D73900 UNLOADER CYLINDER [COMPONENT PARTS]	114	H01200 INLET PLATE	157
D74000 OIL COOLER	115	H01400 DUSTING COVER	158
E20000 ACCELERATOR LEVER	116	H01600 THRESHING BONNET	159
E20200 MAIN GEAR SHIFT LEVER	117	H01800 DUST CARRYING VALVE	160
E20400 MAIN GEAR SHIFT ROD	118	H21000 OPEN-CLOSE COVER	161
E20800 RANGE GEAR SHIFT LEVER	119	H21200 THRESHING COVER(FRONT/BACK)	162
E21000 STEERING	120	H21500 THRESHING COVER (SIDE)	163
E21200 BRAKE PEDAL	121	H22000 WINNOWER SHAFT	164
E21400 HARVEST CLUTCH LEVER	122	H22400 THRESHING CYLINDER TENSION ARM	166
E21600 HARVEST ELEVATOR ARM	123	H22600 THRESHING CYLINDER DRIVE CASE	167
E22000 THRESHING CLUTCH LEVER	124	H22700 THRESHING CYLINDER DRIVE SHAFT	168
[DC-68G HARVESKING-REEL/FEEDER]		H30600 THRESHING TENSION ARM	170
F50000 HARVEST FRAME	125	H40000 THRESHING CYLINDER SHAFT	171
F50500 REEL FRAME	126	H40200 THRESHING CYLINDER TOOTH	172
		H40300 CONCAVE	173
		H80401 ROCKING SHAFT LH	174
		H80402 ROCKING SHAFT RH	175
		H80700 ROCKING TENSION ARM	176
		H90300 GRAIN SIEVE	177
		H92001 SIEVE 1	178
		H92002 SIEVE 2	179

CONTENTS

H92100	SIEVE CASE CLOTH	180
J01000	FIRST HORIZONTAL AUGER SHAFT	181
J01100	FIRST BEVEL GEAR CASE	182
J01200	FIRST VERTICAL AUGER SHAFT	183
J01500	FIRST TENSION ARM	184
J01600	SECOND HORIZONTAL AUGER SHAFT ...	185
J01700	SECOND DRIVE CHAIN CASE	186
J01800	SECOND CASE	187
J01900	SECOND BEVEL GEAR CASE	188
J02000	SECOND VERTICAL AUGER SHAFT	189
[DC-68G HARVESKING-GRAIN TANK]		
K00000	GRAIN TANK GUIDE	190
K00100	GRAIN TANK	191
K00300	CLEANING PORT	192
K00600	TANK LOCK	193
K10100	TANK COVER REAR	194
K10500	TANK COVER UNDER	195
K18000	TANK DRIVE CASE	196
K20000	UNLOADER CASE 1	197
K20100	TANK SCREW SHAFT	198
K20200	EXHAUST SHUTTER	199
K20500	VERTICAL AUGER SHAFT	200
K20900	MOUNTING FRAME	201
K23000	UNLOADER CASE 2	202
K23400	TRANSMISSION SHAFT	203
K24000	UNLOADER CASE 3	204
K30000	UNLOADER	205
K30300	UNLOADER STAY	206
K31500	TANK DRIVE	207
K31700	TANK CLUTCH	208
[V2403-M-DI-TE-CS3T]		
N10000	LABEL (ENGINE)	209
[DC-68G HARVESKING]		
N10500	LABEL(BODY)	210
[DC-68G HARVESKING-REEL/FEEDER]		
N11000	LABEL(HARVEST)	211
[DC-68G HARVESKING-THRESHING]		
N11500	LABEL(THRESHING)	212
[DC-68G HARVESKING-GRAIN TANK]		
N12500	LABEL (GRAIN TANK)	213
[DC-68G HARVESKING]		
R10000	ACCESSORIES 1	214
R10100	ACCESSORIES 2	215
■	NUMERICAL INDEX	216

SECTION CONTENTS

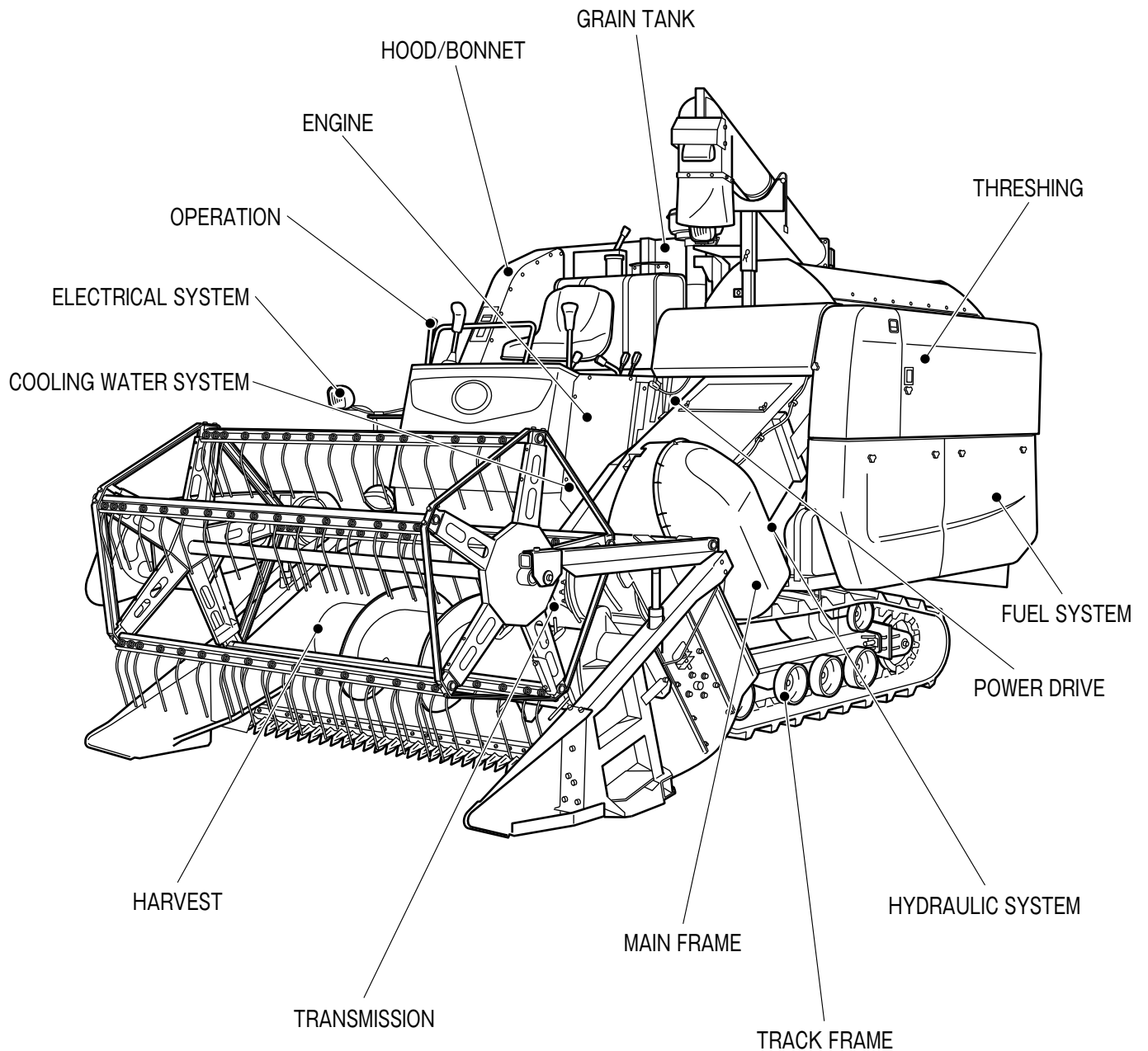



LABELS

ACCESSORIES

[How to read contents with illustrations]

Illustration example

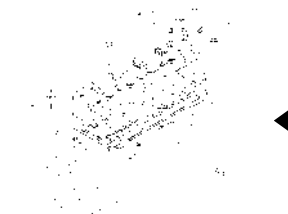
ENGINE ← STEP1			
Fig.No. 000100 CRANKCASE 	Fig.No. 000200 OIL PAN 	Fig.No. 000300 CYLINDER HEAD 	← STEP2 ← STEP3 ← STEP4
Fig.No. 000500 HEAD COVER	Fig.No. 010000 MAIN BEARING CASE	Fig.No. 010100 CAMSHAFT AND IDLE GEAR SHAFT	Fig.No. 010200 PISTON AND CRANKSHAFT

STEP1: This indicates the items listed in SECTION CONTENTS.

STEP2: These indicate the figure number given in the text.

(Fig. No...000300)

STEP3: This indicates the group name in the text.



STEP4: This indicates the illustrations of the group in the text.

How to retrieve:

Look at SECTION CONTENTS to select an item you are looking for. In STEP1, find the same item. In STEP4, find the part you are searching. In STEP2 and STEP3, refer to the page of the group and retrieve the part number.

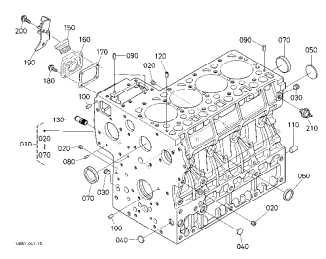
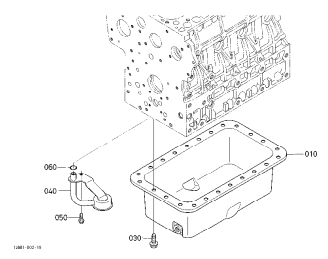
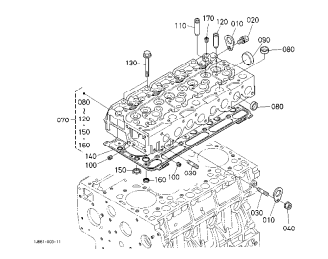
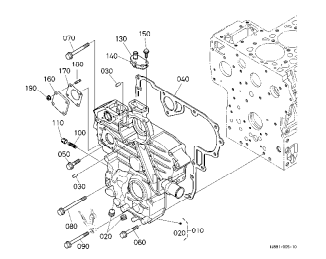
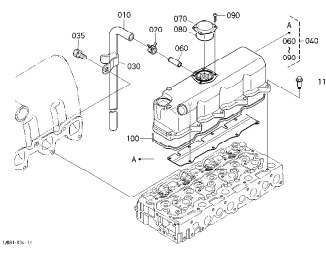
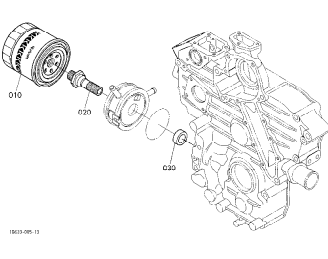
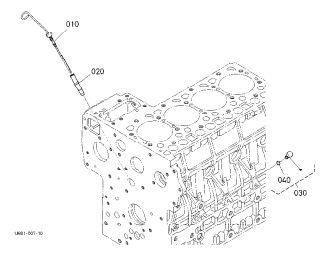
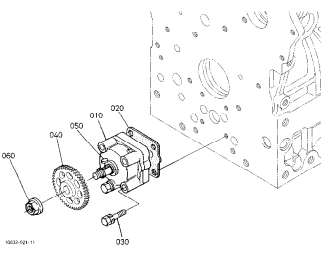
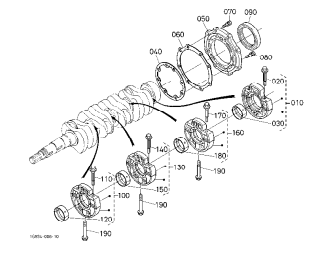
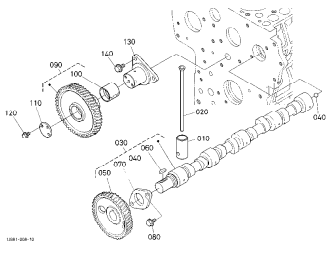
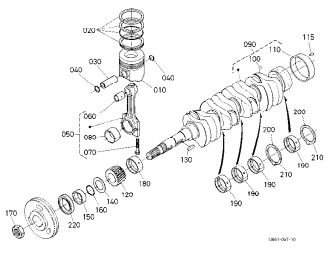
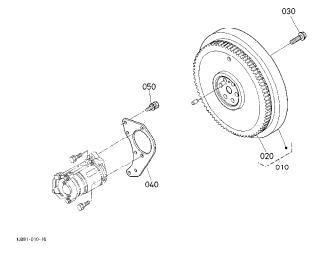
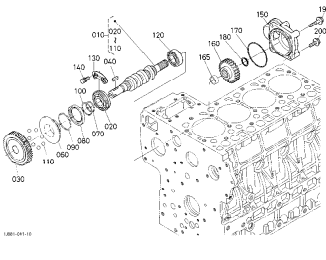
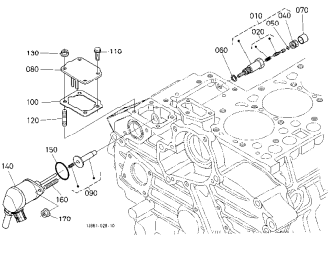
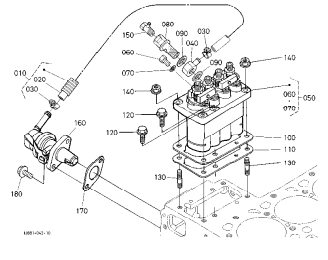
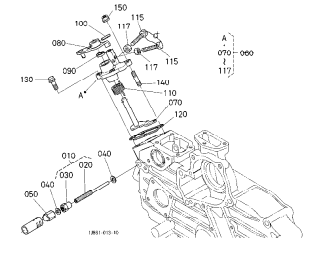
ENGINE

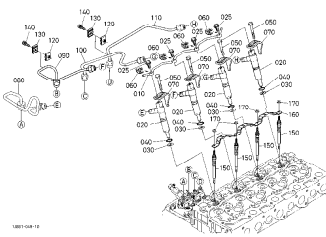
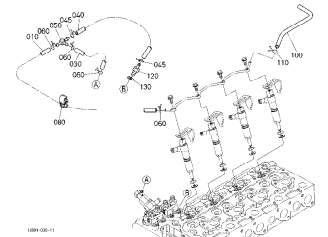
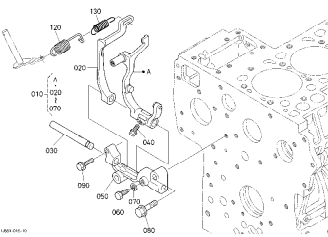
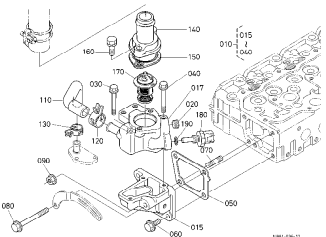
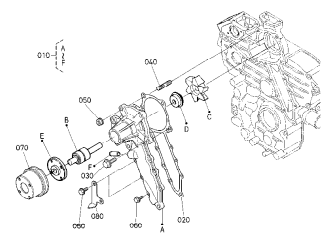
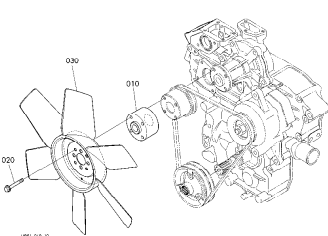
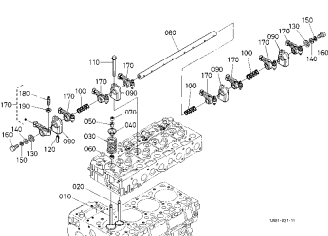
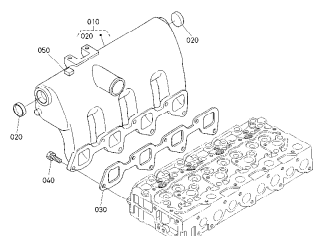
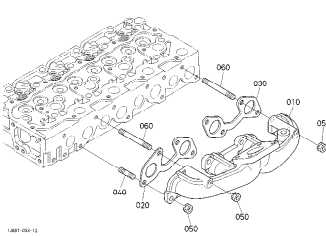
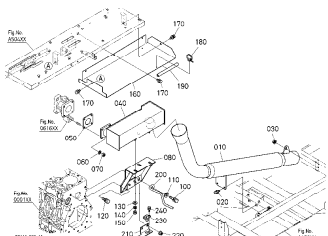
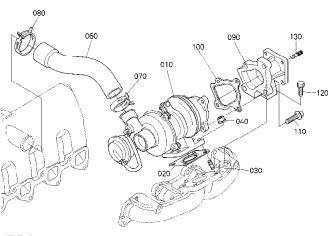
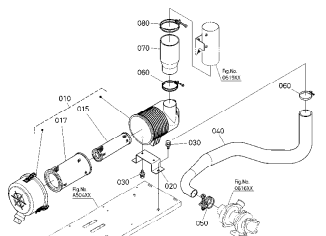
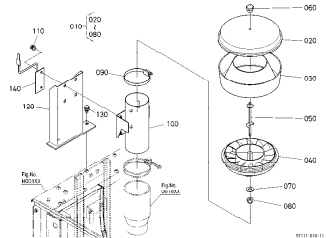
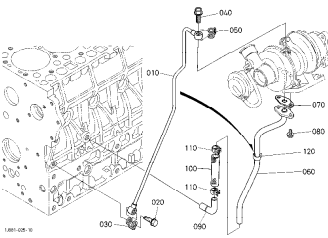
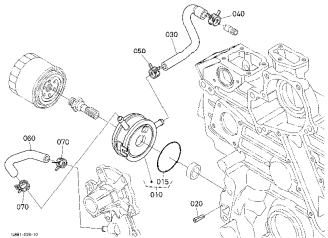
<p>Fig.No. 000100</p> <p>CRANKCASE</p> 	<p>Fig.No. 000200</p> <p>OIL PAN</p> 	<p>Fig.No. 000300</p> <p>CYLINDER HEAD</p> 	<p>Fig.No. 000400</p> <p>GEAR CASE</p> 
<p>Fig.No. 000500</p> <p>HEAD COVER</p> 	<p>Fig.No. 000600</p> <p>OIL FILTER</p> 	<p>Fig.No. 000700</p> <p>DIPSTICK AND GUIDE</p> 	<p>Fig.No. 000800</p> <p>OIL PUMP</p> 
<p>Fig.No. 010000</p> <p>MAIN BEARING CASE</p> 	<p>Fig.No. 010100</p> <p>CAMSHAFT AND IDLE GEAR SHAFT</p> 	<p>Fig.No. 010200</p> <p>PISTON AND CRANKSHAFT</p> 	<p>Fig.No. 010300</p> <p>FLYWHEEL</p> 
<p>Fig.No. 010500</p> <p>FUEL CAMSHAFT AND GOVERNOR SHAFT</p> 	<p>Fig.No. 020000</p> <p>IDLE APPARATUS</p> 	<p>Fig.No. 020200</p> <p>INJECTION PUMP</p> 	<p>Fig.No. 020500</p> <p>SPEED CONTROL PLATE</p> 

<p>Fig.No. 020601</p> <p>NOZZLE HOLDER</p> 	<p>Fig.No. 020602</p> <p>OVER FLOW PIPE</p> 	<p>Fig.No. 021200</p> <p>FORK LEVER(GOVERNOR)</p> 	<p>Fig.No. 050000</p> <p>WATER FLANGE AND THERMOSTAT</p> 
<p>Fig.No. 050100</p> <p>WATER PUMP</p> 	<p>Fig.No. 050400</p> <p>COOLER FAN</p> 	<p>Fig.No. 060000</p> <p>VALVE AND ROCKER ARM</p> 	<p>Fig.No. 060100</p> <p>INLET MANIFOLD</p> 
<p>Fig.No. 060200</p> <p>EXHAUST MANIFOLD</p> 	<p>Fig.No. 061200</p> <p>MUFFLER</p> 	<p>Fig.No. 061600</p> <p>TURBO CHARGER</p> 	<p>Fig.No. 061800</p> <p>AIR CLEANER</p> 
<p>Fig.No. 061900</p> <p>PRE-CLEANER</p> 	<p>Fig.No. 062000</p> <p>OIL PIPE (TURBO CHARGER)</p> 	<p>Fig.No. 070200</p> <p>OIL COOLER</p> 	<p>Fig.No. 070200</p> <p>OIL COOLER</p> 

FUEL SYSTEM

Fig.No. 130400

FUEL TANK

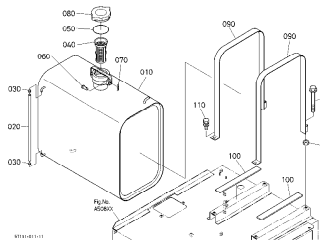

Fig.No. 132500

FUEL PIPE AND FUEL FILTER

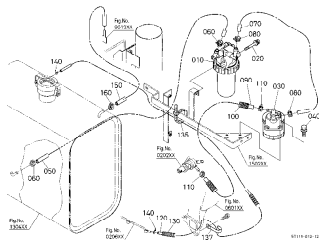

Fig.No. 132600

FUEL FILTER [COMPONENT PARTS]

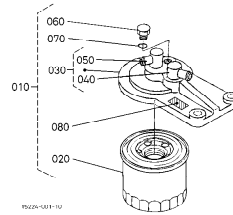
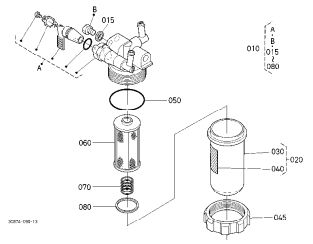

Fig.No. 133000

SEPARATOR [COMPONENT PARTS]



COOLING WATER SYSTEM

Fig.No. 150200

RADIATOR

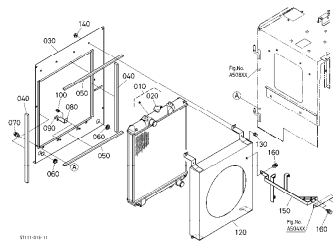

Fig.No. 150300

WATER PIPE

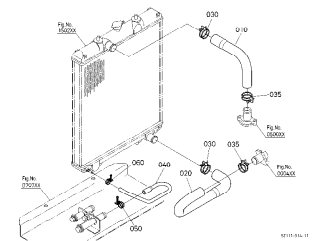
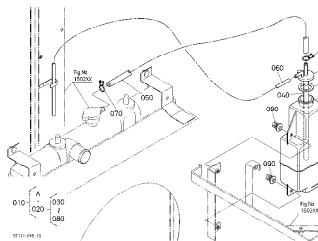

Fig.No. 150500

RESERVE TANK



ELECTRICAL SYSTEM

Fig.No. 501000

ALTERNATOR

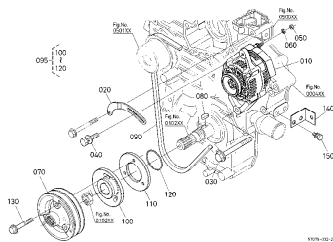

Fig.No. 502000

ALTERNATOR [COMPONENT PARTS]

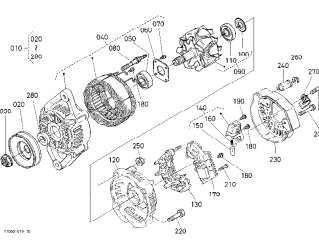

Fig.No. 505000

STARTER

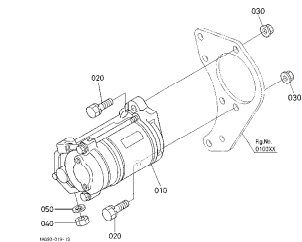

Fig.No. 506000

STARTER [COMPONENT PARTS]

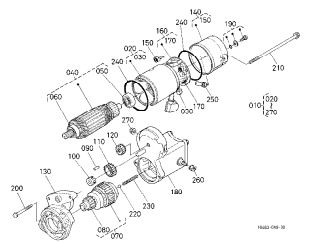

Fig.No. 511000

BATTERY

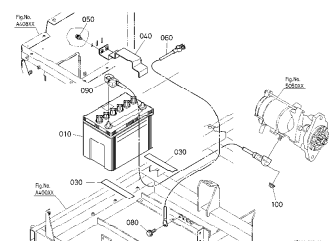

Fig.No. 522800

BODY RELAY/HORN/SENSOR

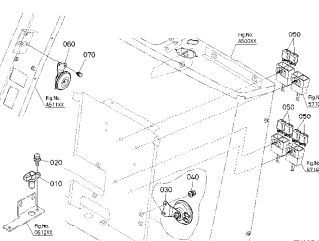

Fig.No. 523000

COCKPIT SWITCH

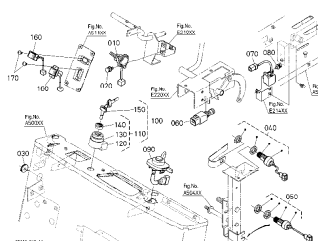

Fig.No. 531000

FRONT PANEL

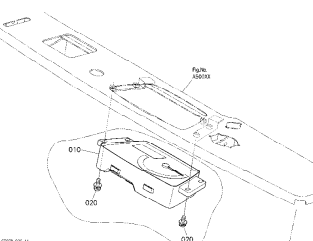



Fig.No. 531400
SWITCH/SENSOR(THRESHING)

Fig. No. 531400

Fig.No. 531801
SWITCH(GRAIN TANK)

Fig. No. 531801

Fig.No. 531802
RELAY/BACK BUZZER(GRAIN TANK)

Fig. No. 531802

Fig.No. 531900
UNLOADER MOTOR

Fig. No. 531900

Fig.No. 541001
WORK LIGHT(BODY)

Fig. No. 541001

Fig.No. 541002
WORK LIGHT(HARVEST)

Fig. No. 541002

Fig.No. 541003
WORK LIGHT(THRESHING)

Fig. No. 541003

Fig.No. 541004
WORK LIGHT (GRAIN TANK)

Fig. No. 541004

Fig.No. 571000
WIRE HARNESS(BODY)

Fig. No. 571000

Fig.No. 571700
WIRE HARNESS(HARVEST)

Fig. No. 571700

Fig.No. 572000
WIRE HARNESS(THRESHING)

Fig. No. 572000

Fig.No. 573000
WIRE HARNESS (GRAIN TANK)

Fig. No. 573000

MAIN FRAME

Fig.No. A40000
MAIN FRAME

Fig. No. A40000

Fig.No. A40500
ENGINE BASE

Fig. No. A40500

Fig.No. A40800
DECK

Fig. No. A40800

HOOD/BONNET

<p>Fig.No. A50000</p> <p>OPERATION FRAME</p>	<p>Fig.No. A50400</p> <p>OPERATION PANEL</p>	<p>Fig.No. A50800</p> <p>SEAT</p>	<p>Fig.No. A50900</p> <p>TOOL BOX</p>
---	---	--	--

<p>Fig.No. A51000</p> <p>DUSTPROOF COVER 1</p>	<p>Fig.No. A51100</p> <p>DUSTPROOF COVER 2</p>	<p>Fig.No. A51500</p> <p>CANOPY</p>	
---	---	--	--

POWER DRIVE

<p>Fig.No. A60000</p> <p>COUNTER PULLEY</p>	<p>Fig.No. A60500</p> <p>TENSION (TRAVEL)</p>		
--	--	--	--

TRANSMISSION

<p>Fig.No. B30000</p> <p>TRANSMISSION CASE</p>	<p>Fig.No. B31000</p> <p>HST</p>	<p>Fig.No. B31100</p> <p>HST [COMPONENT PARTS] 1</p>	<p>Fig.No. B31200</p> <p>HST [COMPONENT PARTS] 2</p>
---	---	---	---



Fig.No. B31300
HST [COMPONENT PARTS] 3

Fig.No. B31400
HST [COMPONENT PARTS] 4

Fig.No. B31500
HST [COMPONENT PARTS] 5

Fig.No. B31800
HST INPUT SHAFT

Fig.No. B32000
TRANSMISSION CASE INSIDE 1

Fig.No. B32400
TRANSMISSION CASE INSIDE 2

Fig.No. B32800
TRANSMISSION CASE INSIDE 3

Fig.No. B33000
TRANSMISSION CASE INSIDE 4

Fig.No. B33200
BRAKE

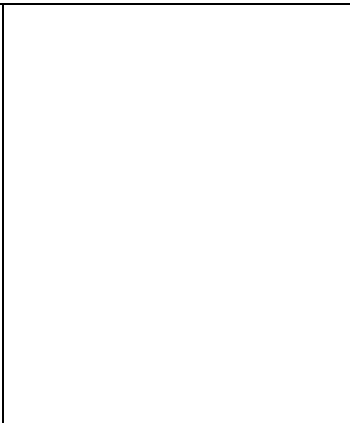
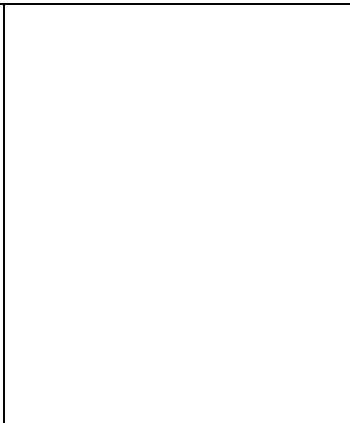
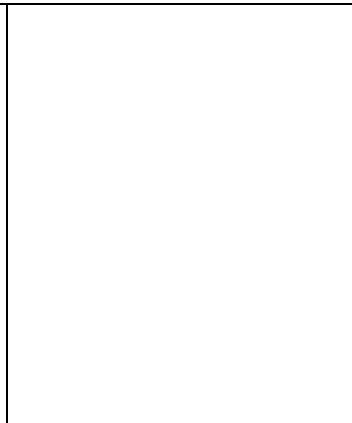

TRACK FRAME

Fig.No. C10000
CRAWLER

Fig.No. C10101
TRACK ROLLER LH

Fig.No. C10102
TRACK ROLLER RH

Fig.No. C10301
TENSION FRAME LH

<p>Fig.No. C10302</p> <p>TENSION FRAME RH</p>	<p>Fig.No. C10401</p> <p>CRAWLER GUIDE LH</p>	<p>Fig.No. C10402</p> <p>CRAWLER GUIDE RH</p>	<p>Fig.No. C10501</p> <p>DRIVE ROLLER LH</p>
--	--	--	---

<p>Fig.No. C10502</p> <p>DRIVE ROLLER RH</p>			
---	--	--	--

HYDRAULIC SYSTEM

<p>Fig.No. D70000</p> <p>HYDRAULIC TANK</p>	<p>Fig.No. D70500</p> <p>HYDRAULIC PUMP</p>	<p>Fig.No. D70600</p> <p>HYDRAULIC PUMP [COMPONENT PARTS]</p>	<p>Fig.No. D70700</p> <p>OIL DRAIN HOSE</p>
--	--	--	--

<p>Fig.No. D71000</p> <p>HYDRAULIC HOSE 1</p>	<p>Fig.No. D71100</p> <p>HYDRAULIC HOSE 2</p>	<p>Fig.No. D71200</p> <p>HYDRAULIC HOSE 3</p>	<p>Fig.No. D71600</p> <p>HYDRAULIC HOSE 4</p>
--	--	--	--

OPERATION

Fig.No. **E20000**

ACCELERATOR LEVER

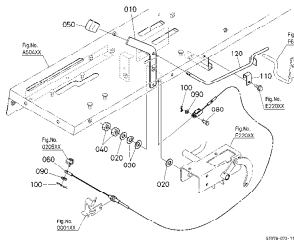

Fig.No. **E20200**

MAIN GEAR SHIFT LEVER

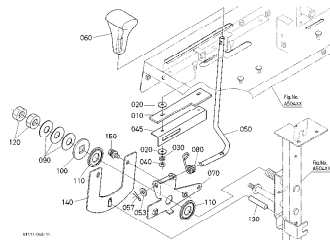

Fig.No. **E20400**

MAIN GEAR SHIFT ROD

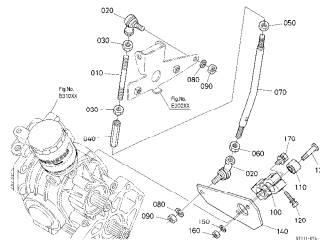

Fig.No. **E20800**

RANGE GEAR SHIFT LEVER

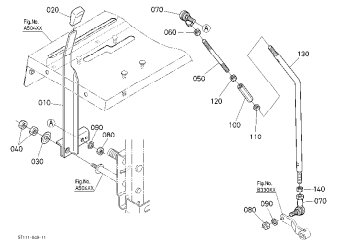

Fig.No. **E21000**

STEERING

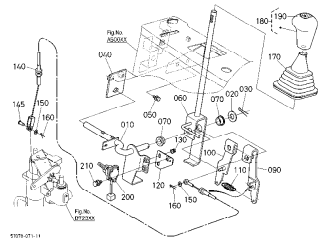

Fig.No. **E21200**

BRAKE PEDAL

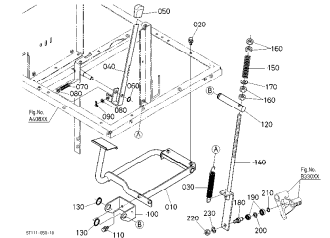

Fig.No. **E21400**

HARVEST CLUTCH LEVER

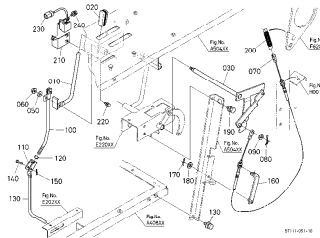

Fig.No. **E21600**

HARVEST ELEVATOR ARM

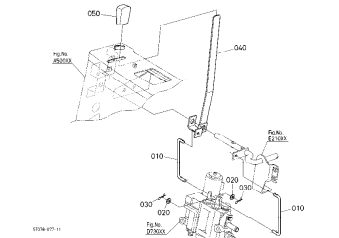
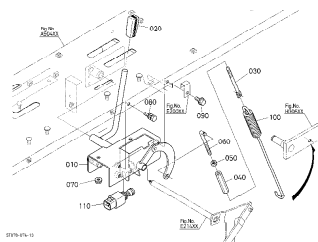

Fig.No. **E22000**

THRASHING CLUTCH LEVER



HARVEST

Fig.No. **F50000**

HARVEST FRAME

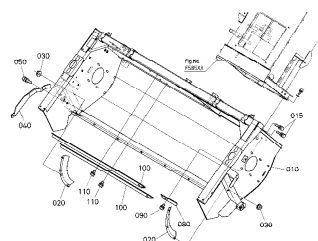

Fig.No. **F50500**

REEL FRAME

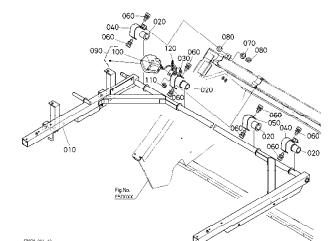

Fig.No. **F51000**

HARVEST FRAME COVER

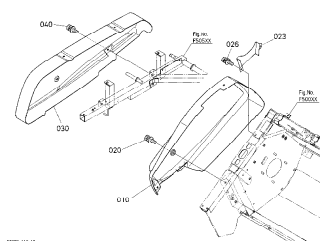

Fig.No. **F51500**

REEL CENTER SHAFT

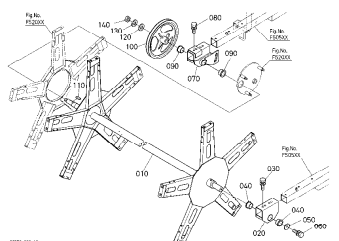

Fig.No. F52000
REEL ADJUSTMENT

Fig.No. F52500
TINE

Fig.No. F53000
BLADE REAPING

Fig.No. F53500
TENSION ARM

Fig.No. F54000
AUGER DRUM

Fig.No. F54500
AUGER DRUM SHAFT

Fig.No. F55000
AUGER DRUM CHAIN

Fig.No. F55500
FINGER SHAFT

Fig.No. F56000
DIVIDER LH

Fig.No. F56500
DIVIDER RH

Fig.No. F57000
BLADE REAPING DRIVE ARM

Fig.No. F57500
BLADE REAPING DRIVE SHAFT

Fig.No. F58000
HARVEST DRIVE SHAFT

Fig.No. F58500
FEEDER FRAME

Fig.No. F59000
FEEDER COVER

Fig.No. F59500
FEEDER FAN COVER

<p>Fig.No. F60000</p> <p>FEEDER DRUM</p>	<p>Fig.No. F60500</p> <p>FEEDER DRIVE CHAIN</p>	<p>Fig.No. F61000</p> <p>HARVEST DRIVE CHAIN</p>	<p>Fig.No. F61500</p> <p>FEEDER DRIVE SHAFT</p>
--	---	--	---

THRESHING

<p>Fig.No. F62000</p> <p>HARVEST TENSION ARM</p>	<p>Fig.No. F62500</p> <p>HARVEST REVERSAL LEVER</p>	<p>Fig.No. H00101</p> <p>THRESHING FRAME(UPPER)</p>	<p>Fig.No. H00102</p> <p>THRESHING FRAME(LOWER)</p>
--	---	---	---

<p>Fig.No. H01000</p> <p>WINNOWER PLATE</p>	<p>Fig.No. H01100</p> <p>WIND DIRECTION PLATE</p>	<p>Fig.No. H01200</p> <p>INLET PLATE</p>	<p>Fig.No. H01400</p> <p>DUSTING COVER</p>
---	---	--	--

<p>Fig.No. H01600</p> <p>THRESHING BONNET</p>	<p>Fig.No. H01800</p> <p>DUST CARRYING VALVE</p>	<p>Fig.No. H21000</p> <p>OPEN-CLOSE COVER</p>	<p>Fig.No. H21200</p> <p>THRESHING COVER(FRONT/BACK)</p>
---	--	---	--

<p>Fig.No. H21500</p> <p>THRESHING COVER (SIDE)</p> 	<p>Fig.No. H22000</p> <p>WINNOWER SHAFT</p> 	<p>Fig.No. H22400</p> <p>THRESHING CYLINDER TENSION ARM</p> 	<p>Fig.No. H22600</p> <p>THRESHING CYLINDER DRIVE CASE</p> 
<p>Fig.No. H22700</p> <p>THRESHING CYLINDER DRIVE SHAFT</p> 	<p>Fig.No. H30600</p> <p>THRESHING TENSION ARM</p> 	<p>Fig.No. H40000</p> <p>THRESHING CYLINDER SHAFT</p> 	<p>Fig.No. H40200</p> <p>THRESHING CYLINDER TOOTH</p> 
<p>Fig.No. H40300</p> <p>CONCAVE</p> 	<p>Fig.No. H80401</p> <p>ROCKING SHAFT LH</p> 	<p>Fig.No. H80402</p> <p>ROCKING SHAFT RH</p> 	<p>Fig.No. H80700</p> <p>ROCKING TENSION ARM</p> 
<p>Fig.No. H90300</p> <p>GRAIN SIEVE</p> 	<p>Fig.No. H92001</p> <p>SIEVE 1</p> 	<p>Fig.No. H92002</p> <p>SIEVE 2</p> 	<p>Fig.No. H92100</p> <p>SIEVE CASE CLOTH</p> 



Fig.No. J01000
FIRST HORIZONTAL AUGER SHAFT

Fig.No. J01100
FIRST BEVEL GEAR CASE

Fig.No. J01200
FIRST VERTICAL AUGER SHAFT

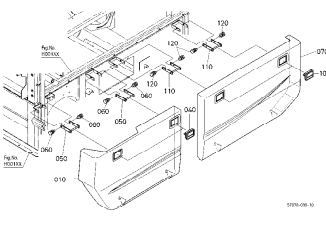
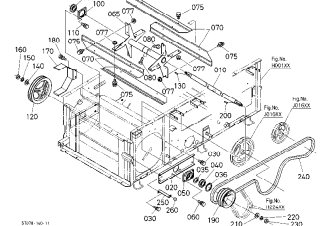
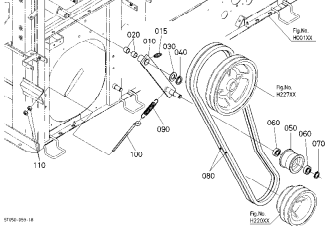
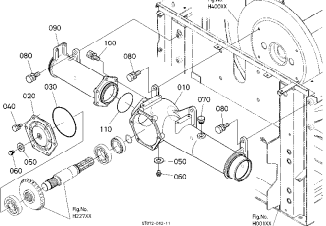
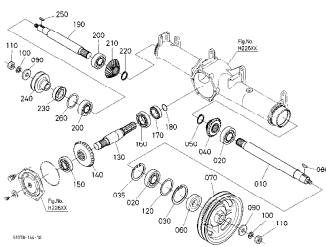
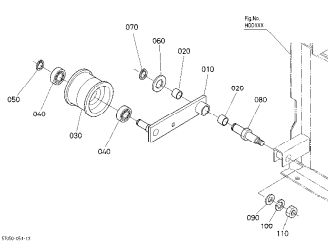
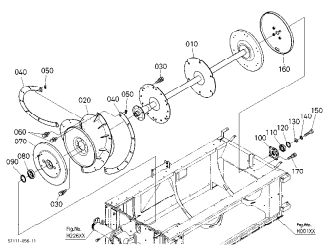
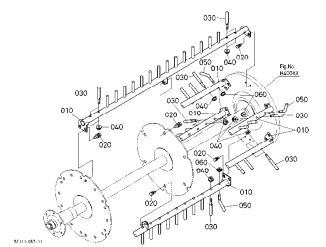
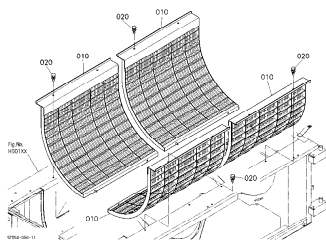
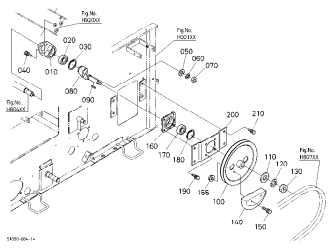
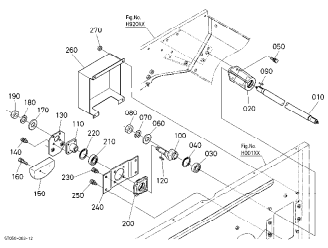
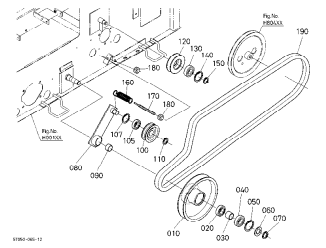
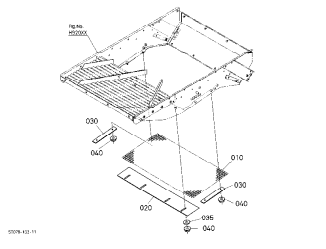
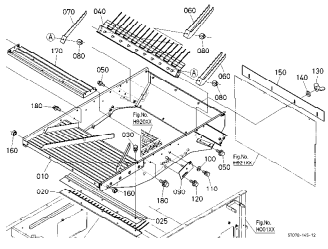
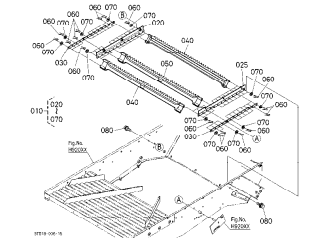
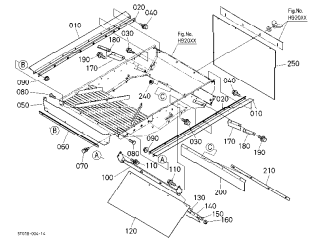
Fig.No. J01500
FIRST TENSION ARM

Fig.No. J01600
SECOND HORIZONTAL AUGER SHAFT

Fig.No. J01700
SECOND DRIVE CHAIN CASE

Fig.No. J01800
SECOND CASE

Fig.No. J01900
SECOND BEVEL GEAR CASE

Fig.No. J02000
SECOND VERTICAL AUGER SHAFT

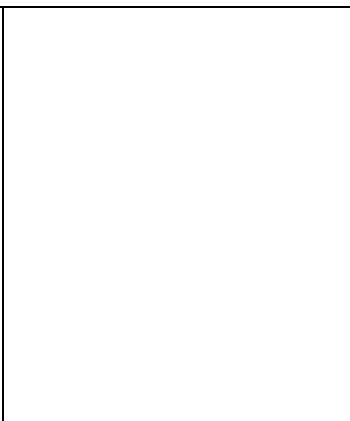
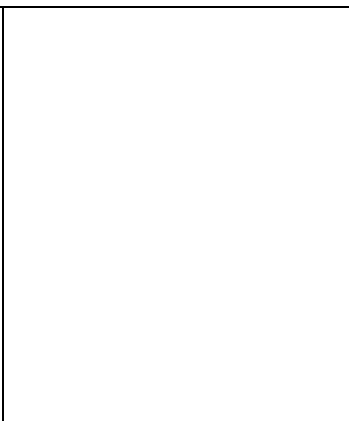
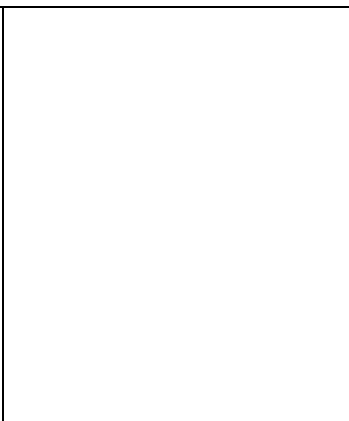

GRAIN TANK

Fig.No. K00000
GRAIN TANK GUIDE

Fig.No. K00100
GRAIN TANK

Fig.No. K00300
CLEANING PORT

Fig.No. K00600
TANK LOCK

<p>Fig.No. K10100</p> <p>TANK COVER REAR</p>	<p>Fig.No. K10500</p> <p>TANK COVER UNDER</p>	<p>Fig.No. K18000</p> <p>TANK DRIVE CASE</p>	<p>Fig.No. K20000</p> <p>UNLOADER CASE 1</p>
<p>Fig.No. K20100</p> <p>TANK SCREW SHAFT</p>	<p>Fig.No. K20200</p> <p>EXHAUST SHUTTER</p>	<p>Fig.No. K20500</p> <p>VERTICAL AUGER SHAFT</p>	<p>Fig.No. K20900</p> <p>MOUNTING FRAME</p>
<p>Fig.No. K23000</p> <p>UNLOADER CASE 2</p>	<p>Fig.No. K23400</p> <p>TRANSMISSION SHAFT</p>	<p>Fig.No. K24000</p> <p>UNLOADER CASE 3</p>	<p>Fig.No. K30000</p> <p>UNLOADER</p>
<p>Fig.No. K30300</p> <p>UNLOADER STAY</p>	<p>Fig.No. K31500</p> <p>TANK DRIVE</p>	<p>Fig.No. K31700</p> <p>TANK CLUTCH</p>	<p>Fig.No. K31700</p> <p>TANK CLUTCH</p>

LABELS

<p>Fig.No. N10000</p> <p>LABEL (ENGINE)</p>	<p>Fig.No. N10500</p> <p>LABEL(BODY)</p>	<p>Fig.No. N11000</p> <p>LABEL(HARVEST)</p>
--	---	--

010200 PISTON AND CRANKSHAFT

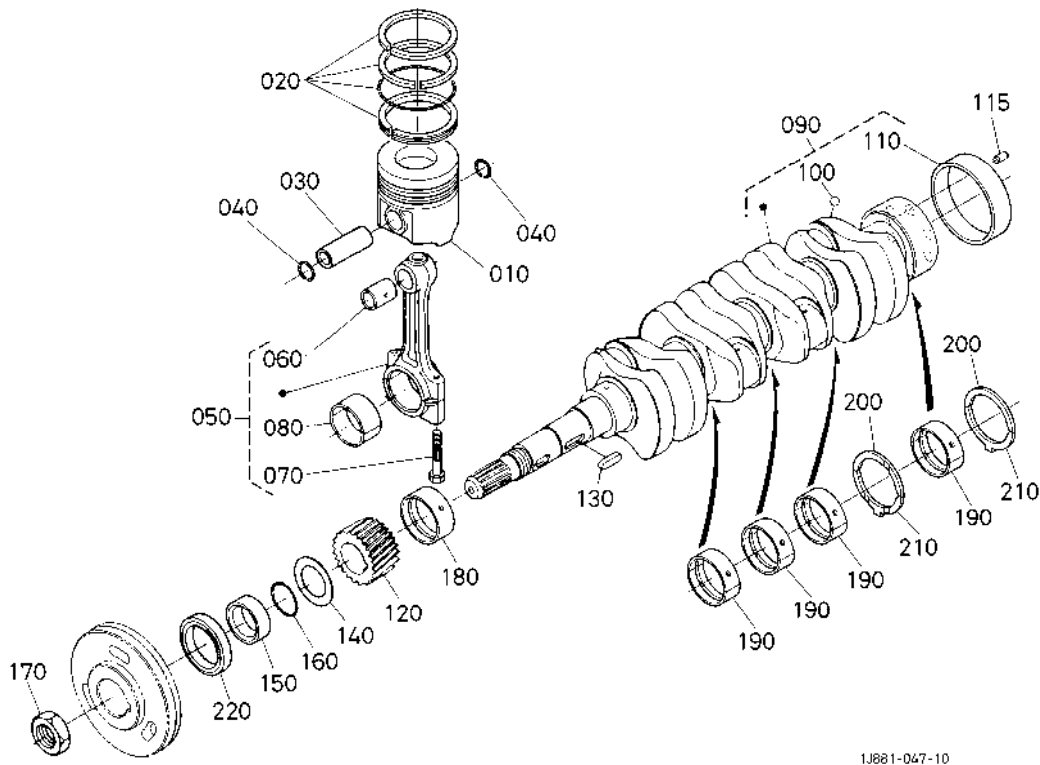

A:V2403-M-DI-TE-CS3T

REF.No.	PART No.	PART NAME	Q'TY/S.No.	I.C.	REMARKS
			A		
010	1J881-2111-0	PISTON	4		(H05)STD
010	1J881-2190-0	PISTON	4		(H05)+0.25mm
020	1J881-2105-0	ASSY PISTON RING	4		STD
020	1J881-2109-0	ASSY PISTON RING	4		+0.25mm
030	1J864-2131-0	PISTON PIN	4		
040	1J864-2133-0	CIR-CLIP,INTERNAL	8		
050	1J881-2201-2	ROD,CONNECTING,ASSY	4		
060	1G924-2198-0	BUSHING(PIN,PISTON)	4		
070	1J864-2214-0	BOLT,CONNECTING ROD	8		
080	1J864-2231-0	METAL,CRANKPIN	4		STD/SET
080	1J864-2297-0	METAL,CRANKPIN	4		-0.20mm/SET
080	1J864-2298-0	METAL,CRANKPIN	4		-0.40mm/SET
090	1J881-2301-0	COMP,CRANKSHAFT	1		
100	07715-00401	BALL 1/4	4		
110	1J864-2328-2	BUSH,CRANKSHAFT	1		
115	1A021-2319-2	PIN,STRAIGHT	1		
120	1J881-2411-0	GEAR,CRANKSHAFT	1		
130	05712-00730	FEATHER KEY	1		
140	1J864-2331-0	SLINGER,OIL(CRANKSHA	1		
150	1J864-2325-0	COLLAR(CRANKSHAFT)	1		
160	04811-10300	O RING	1		
170	15221-2336-0	NUT(CRANKSHAFT)	1		
180	1A091-2347-2	METAL,CRANKSHAFT	1		STD
180	1A091-2391-0	METAL(CRANKSHAFT)	1		-0.20mm
180	1A091-2392-0	METAL(CRANKSHAFT)	1		-0.40mm
190	1J864-2348-0	METAL,CRANKSHAFT	4		STD/SET
190	1J864-2393-0	METAL,CRANKSHAFT	4		-0.20mm/SET
190	1J864-2394-0	METAL,CRANKSHAFT	4		-0.40mm/SET
200	1J864-2353-0	METAL,SIDE	2		STD
200	1J864-2395-0	METAL,SIDE	2		+0.20mm

↔ Interchangeable; ≠ not Interchangeable; ← new for old; → old for new

061200 MUFFLER

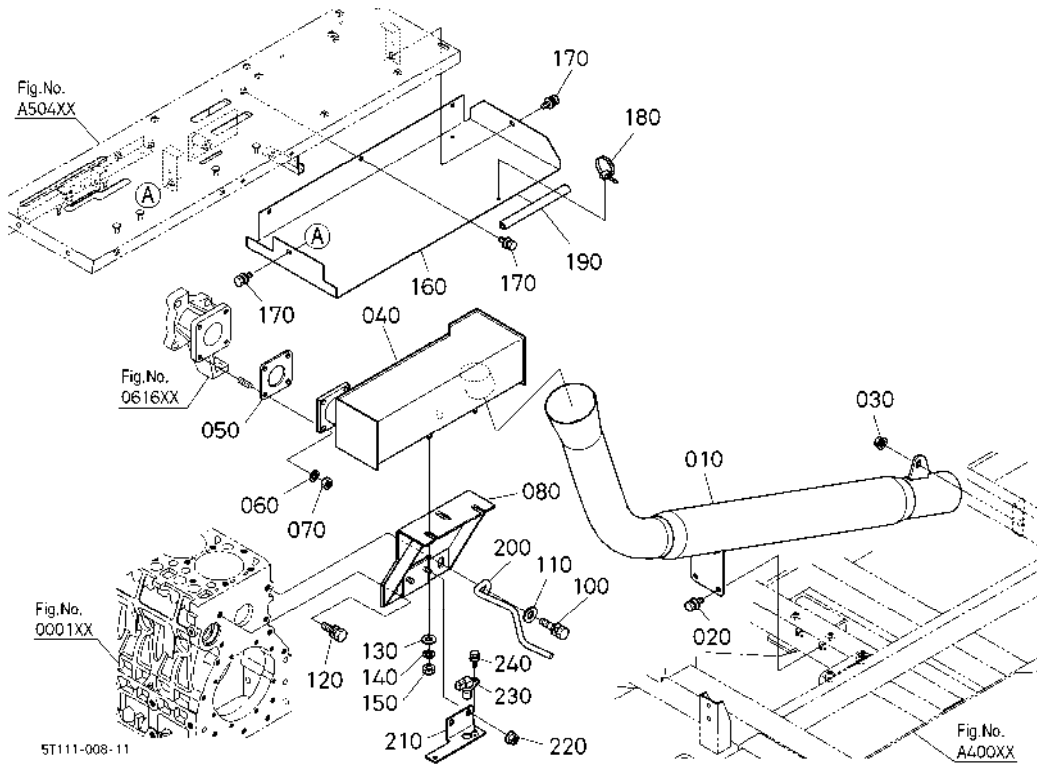

A:DC-68G HARVESKING

REF.No.	PART No.	PART NAME	Q'TY/S.No.	I.C.	REMARKS
			A		
010	5T078-2136-2	PIPE,EXHAUST	1		
020	01125-50820	BOLT,W SEMS	2		
030	02121-50080	NUT	1		
040	5T078-2656-3	COMP.MUFFLER	1		
050	T0070-1642-0	GASKET(MUFFLER)	1		
060	04512-50080	WASHER,SPRING LOCK	4		
070	02114-50080	HEX.NUT	4		
080	5T078-2659-0	STAY,MUFFLER	1		
090	---	BLANK	-		
100	01133-51240	BOLT,SEMS	1		
110	04015-50120	WASHER,PLAIN	1		
120	01135-51230	BOLT,W SEMS	1		
130	04015-50080	WASHER,PLAIN	3		
140	04512-50080	WASHER,SPRING LOCK	3		
150	02114-50080	HEX.NUT	3		
160	5T072-2666-4	COVER,HEAT PROOF	1		
170	01125-50820	BOLT,W SEMS	5		
180	44366-6897-0	BAND,CORD	1		
190	5T072-2116-0	TRIM	1		
200	5T078-1218-0	RETAINER,COUNTER	1		
210	5T078-1112-0	STAY,SENSOR	1		
220	02121-50080	NUT	2		
230	T1060-3227-0	SENSOR(REVOLUTION)	1		
240	01025-50620	BOLT	1		

↔ Interchangeable; ≠ not Interchangeable; ← new for old; → old for new

502000 ALTERNATOR [COMPONENT PARTS]

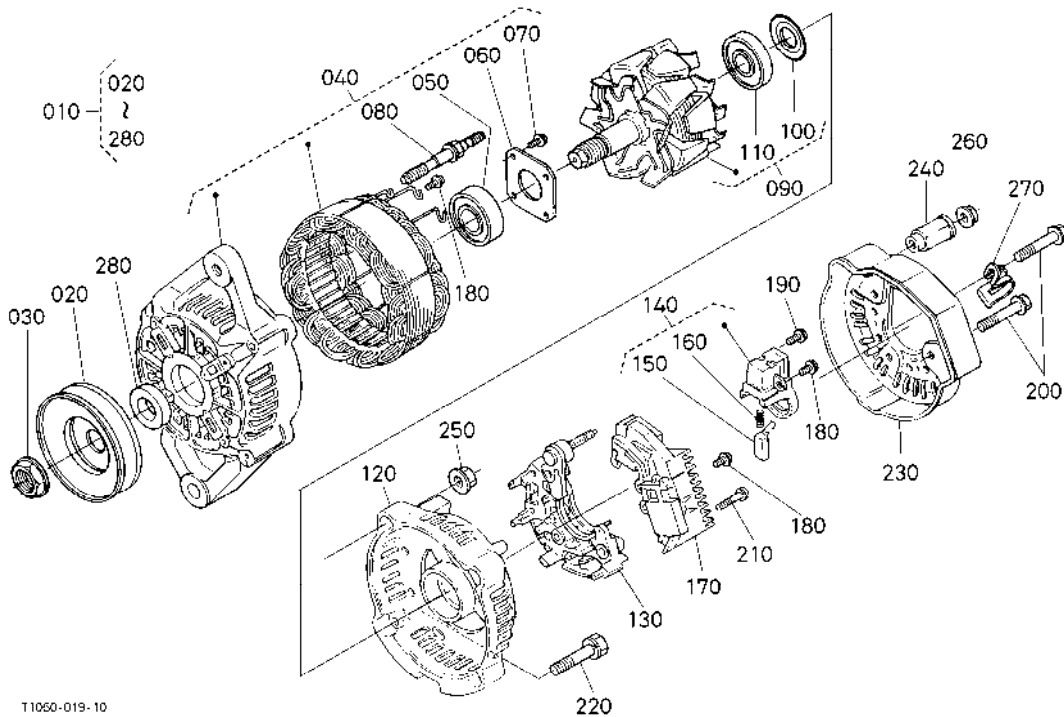

T1060-019-10

A:DC-68G HARVESKING

REF.No.	PART No.	PART NAME	Q'TY/S.No.	I.C.	REMARKS
			A		
010	5H669-4250-0	ASSY ALTERNATOR	1		60A
020	5H730-4251-0	PULLEY,ALTERNATOR	1		
030	15881-9201-0	NUT	1		
040	1K411-6402-0	ASSY FRAME,DRIVE END	1		
050	16652-6478-0	BRG,BALL	1		
060	15881-6471-0	PLATE(RETAINER)	1		
070	15881-9301-0	SCREW,RD HD	4		
080	15881-6426-0	BOLT(THROUGH)	2		
090	TA043-6404-0	ROTOR	1		
100	15881-6480-0	COVER(BEARING)	1		
110	16652-6477-0	BRG,BALL	1		
120	T1065-1561-0	FRAME,END(REAR)	1		
130	T1275-1563-0	HOLDER	1		
140	16652-6431-0	HOLDER(BRUSH)	1		
150	15881-6409-0	BRUSH	2		
160	15881-6433-0	SPRING(BRUSH)	2		
170	1K531-6460-2	ASSY REGULATOR	1		
180	15881-9303-0	SCREW,RD HD	6		
190	15881-9304-0	SCREW,RD HD	1		
200	15881-9104-0	BOLT	3		
210	15881-9302-0	SCREW,RD HD	2		
220	15881-9105-0	BOLT	2		
230	T1065-1566-0	COVER(END REAR)	1		
240	16241-6490-0	BUSHING(INSULATION)	1		
250	15881-9202-0	NUT	2		
260	14182-9203-0	NUT	1		
270	17369-6757-0	CLAMP,CORD	1		
280	15881-6415-0	COLLAR	1		

↔ Interchangeable; ≠ not Interchangeable; ← new for old; → old for new

506000 STARTER [COMPONENT PARTS]

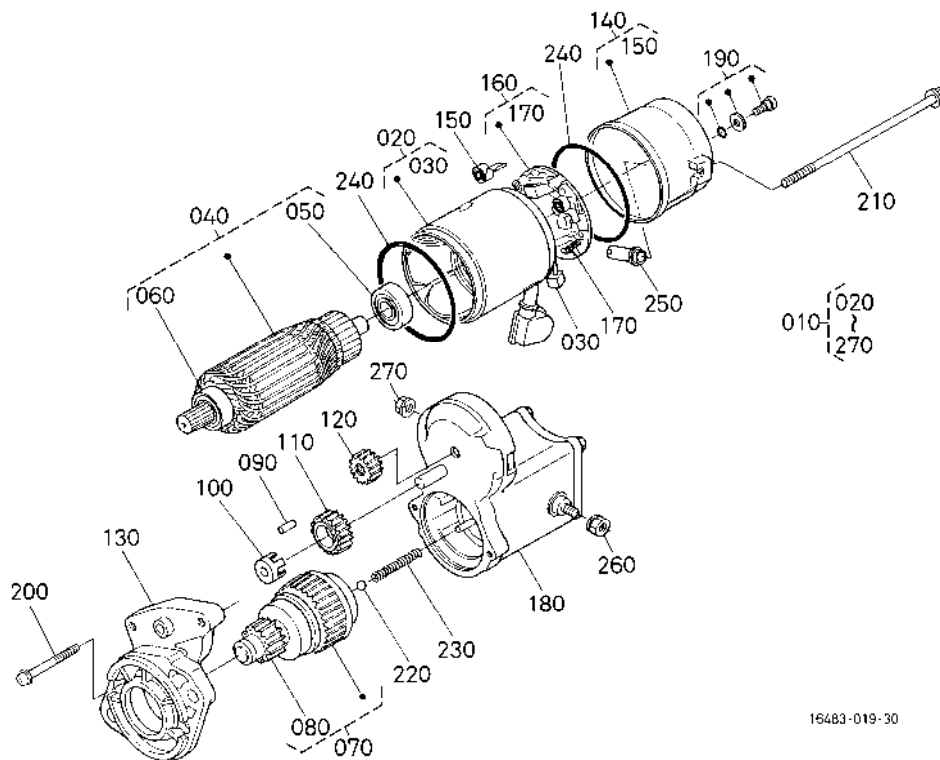

16483-019-30

A:DC-68G HARVESKING

REF.No.	PART No.	PART NAME	Q'TY/S.No.	I.C.	REMARKS
			A		
010	17123-6301-6	ASSY STARTER	1		
020	17123-6308-0	YOKE	1		
030	15425-6340-0	BRUSH,KIT	2		
040	17123-6307-0	ARMATURE	1		
050	17123-6350-0	BEARING	1		
060	11460-6350-0	BEARING	1		
070	17123-6304-0	CLUTCH(OVER RUNNING)	1		
080	17311-6328-0	GEAR(PINION)	1		
090	19212-6310-0	ROLLER	5		
100	11460-6311-0	RETAINER	1		
110	11460-6327-0	GEAR	1		
120	17123-6326-0	GEAR	1		
130	17123-6303-0	FRAME(DRIVE END)	1		
140	17123-6320-0	FRAME,END	1		
150	15425-6339-0	SPRING(BRUSH)	4		
160	17123-6338-0	HOLDER(BRUSH)	1		
170	17123-6314-0	SPRING	4		
180	17123-6302-4	ASSY SWITCH,MAGNETIC	1		
190	17123-9331-0	SCREW,PAN HD	2		
200	17123-9332-0	SCREW,PAN HD	2		
210	17123-6332-0	BOLT(THROUGH)	2		
220	19212-9713-0	BALL	1		
230	11460-6312-0	SPRING	1		
240	15511-9666-0	O-RING	2		
250	16285-6357-0	PIPE(DRAIN)	1		
260	13963-9201-0	NUT(HEXAGON)	1		
270	16285-9201-0	NUT(HEXAGON)	1		

↔ Interchangeable; ≠ not Interchangeable; ← new for old; → old for new

A50000 OPERATION FRAME

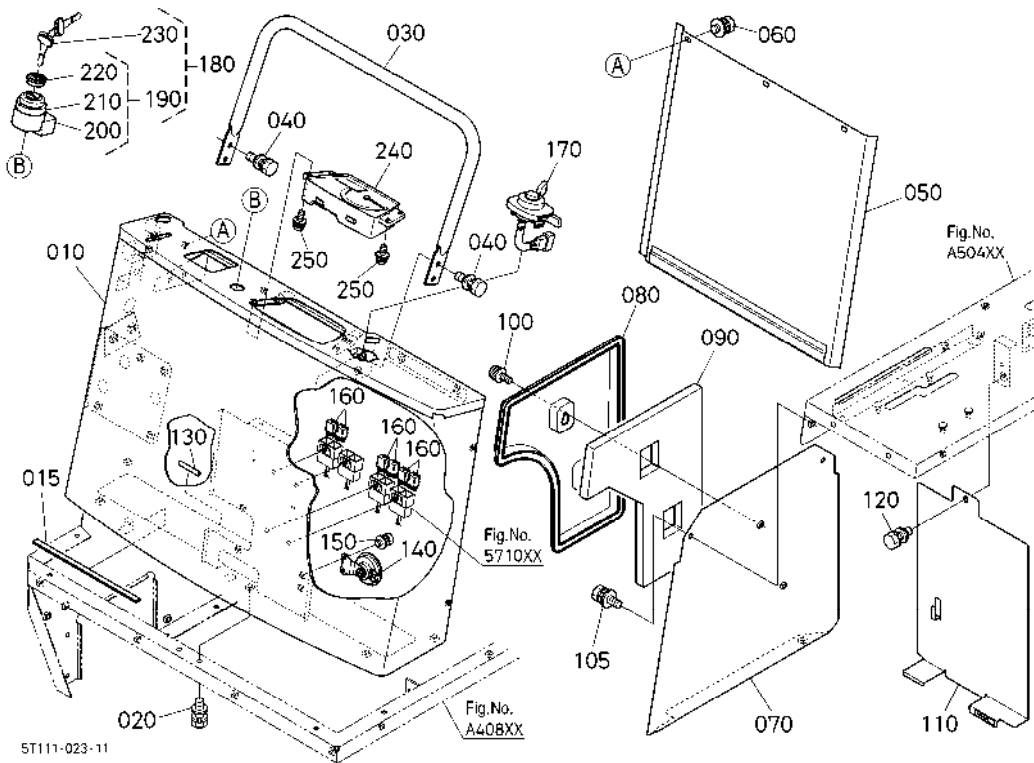

A:DC-68G HARVESKING

REF.No.	PART No.	PART NAME	Q'TY/S.No.	I.C.	REMARKS
			A		
010	5T078-3111-5	FRAME(OPERATION)	1		
015	5H601-2119-0	TRIM	1		
020	01125-50820	BOLT,W SEMS	5		
030	5T072-3134-0	HANDRAIL	1		
040	01125-50820	BOLT,W SEMS	4		
050	5T078-3137-0	COVER,FRAME	1		
060	01025-50612	BOLT	3		
070	5T078-3332-0	COVER,FRAME SIDE	1		
080	5T078-3391-0	COVER	1		
090	5T078-3392-0	SEAL	1		
100	53415-4128-0	PLASTIC BOLT	2		
105	01125-50816	BOLT,W SEMS	2		
110	5T078-3336-3	COVER(HEAT PROOF FR)	1		
120	01125-50816	BOLT,W SEMS	1		
130	5T072-3548-0	TRIM	1		
140	5T072-4251-0	HORN	1		
150	01025-50612	BOLT	2		
160	5H583-4125-0	RELAY	6		
170	5T057-4224-2	SWITCH,COMBINATION	1		
180	5T056-4202-2	SWITCH,STARTER,ASSY	1		
190	5T056-4222-2	SWITCH,STARTER	1		
200	5T056-4242-0	SWITCH,STARTER	1		
210	5T056-4225-0	SEAL,DUST	1		
220	5T056-4227-0	CAP	1		
230	15248-6370-0	KEY,ASSY	1		2P/SET
240	5T111-4121-0	METER,ASSY(IN)	1		
250	03034-50520	SCREW,W SEMS(PAN HEA	4		

↔ Interchangeable; ≠ not Interchangeable; ← new for old; → old for new

A50800 SEAT

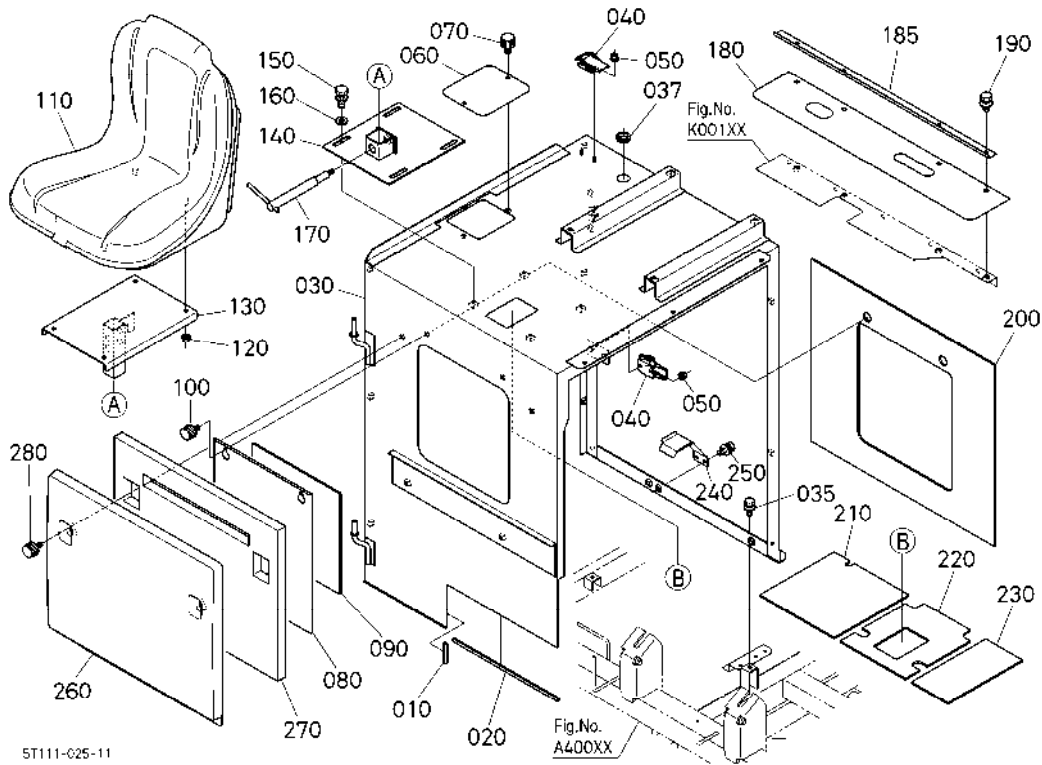

A:DC-68G HARVESKING

REF.No.	PART No.	PART NAME	Q'TY/S.No.	I.C.	REMARKS
			A		
010	5T072-3548-0	TRIM	1		
020	5T072-3549-0	TRIM	1		
030	5T111-3541-3	FRAME(SEAT)	1		
035	01125-50820	BOLT,W SEMS	5		
037	58218-1155-0	GROMMET	1		
040	5T078-7878-0	CLAMP(CATCH)	2		
050	02021-50060	NUT	4		
060	5T072-3542-0	COVER	1		
070	53415-4128-0	PLASTIC BOLT	2		
080	5T078-3543-0	COVER,SEAT FRAME	1		
090	5T078-3751-0	INSULATION,HEAT	1		
100	53415-4128-0	PLASTIC BOLT	2		
110	5H492-3539-0	SEAT	1		
120	02121-50080	NUT	4		
130	5T078-3561-2	STAY(1,SEAT)	1		
140	5T078-3562-2	STAY(2,SEAT)	1		
150	01133-51020	BOLT,SEMS	4		
160	04015-50100	WASHER,PLAIN	4		
170	5T078-3563-0	BOLT,JAKI	1		
180	5T111-3544-2	SEAT(DUST PROOF)	1		
185	5T111-3545-2	STAY(SEAT,DUST)	1		
190	01125-50816	BOLT,W SEMS	4		
200	5T078-3752-0	HEAT INSULATOR(FR)	1		
210	5T078-3755-2	HEAT INSULATOR(DN 3)	1		
220	5T078-3756-0	INSULATION,HEAT	1		
230	5T078-3757-0	INSULATION,HEAT	1		
240	5T072-3546-0	PLATE	1		
250	01125-50820	BOLT,W SEMS	2		
260	5T078-3591-0	COVER	1		
270	5T078-3592-0	SEAL	1		

↔ Interchangeable; ≠ not Interchangeable; ← new for old; → old for new

B32800 TRANSMISSION CASE INSIDE 3

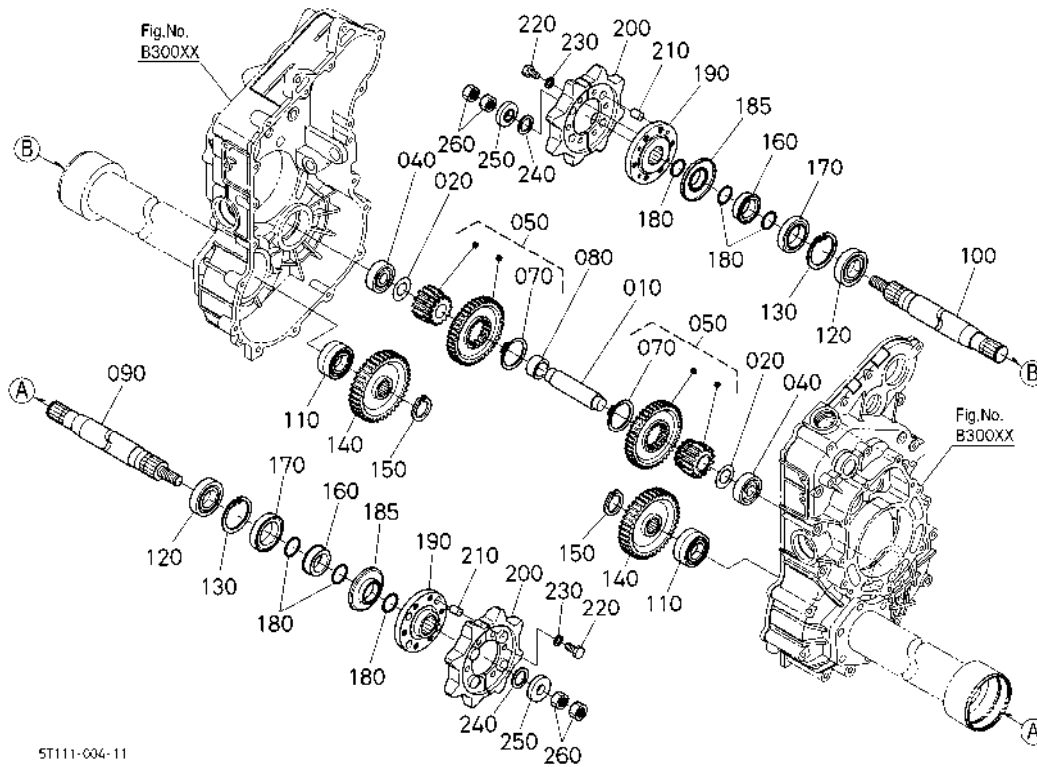

5T111-004-11

A:DC-68G HARVESKING

REF.No.	PART No.	PART NAME	Q'TY/S.No.	I.C.	REMARKS
			A		
010	52270-1621-3	SHAFT, IDLE	1		
020	52270-1623-0	COLLAR, COUNTER SHAFT	2		
030	----	BLANK	-		
040	5H672-1629-0	BEARING, ROLLER	2		
050	5H861-1624-0	GEAR, ASSY	2		14-43T
060	----	BLANK	-		
070	04612-00680	CIR-CLIP, EXTERNAL	2		
080	52200-1628-0	COLLAR	1		
090	5T110-1641-0	AXLE	1		
100	5T110-1642-2	AXLE(543.8)	1		
110	5H658-1632-0	BEARING	2		
120	08141-06209	BEARING, BALL	2		
130	04611-00850	CIR-CLIP, INTERNAL	2		
140	5H658-1643-2	GEAR	2		34T
150	04612-00400	CIR-CLIP, EXTERNAL	2		
160	5T110-1645-0	COLLAR(AxLE)	2		
170	TD250-2756-0	SEAL, OIL	2		
180	04817-06450	O RING	6		
185	5T110-1643-0	COVER(AxLE)	2		
190	5T110-1646-0	BOSS(DRIVE ROLLER)	2		
200	5H601-1645-5	ROLLER, DRIVE	2		
210	3F290-6397-0	PIN, STRAIGHT	8		
220	5H601-1648-0	BOLT	12		
230	04512-50140	WASHER, SPRING LOCK	12		
240	5H801-1649-0	PACKING (17-26)	2		
250	5H801-1647-0	WASHER, PLAIN	2		
260	5H801-1648-0	NUT	4		

↔ Interchangeable; ≠ not Interchangeable; ← new for old; → old for new

B33200 BRAKE

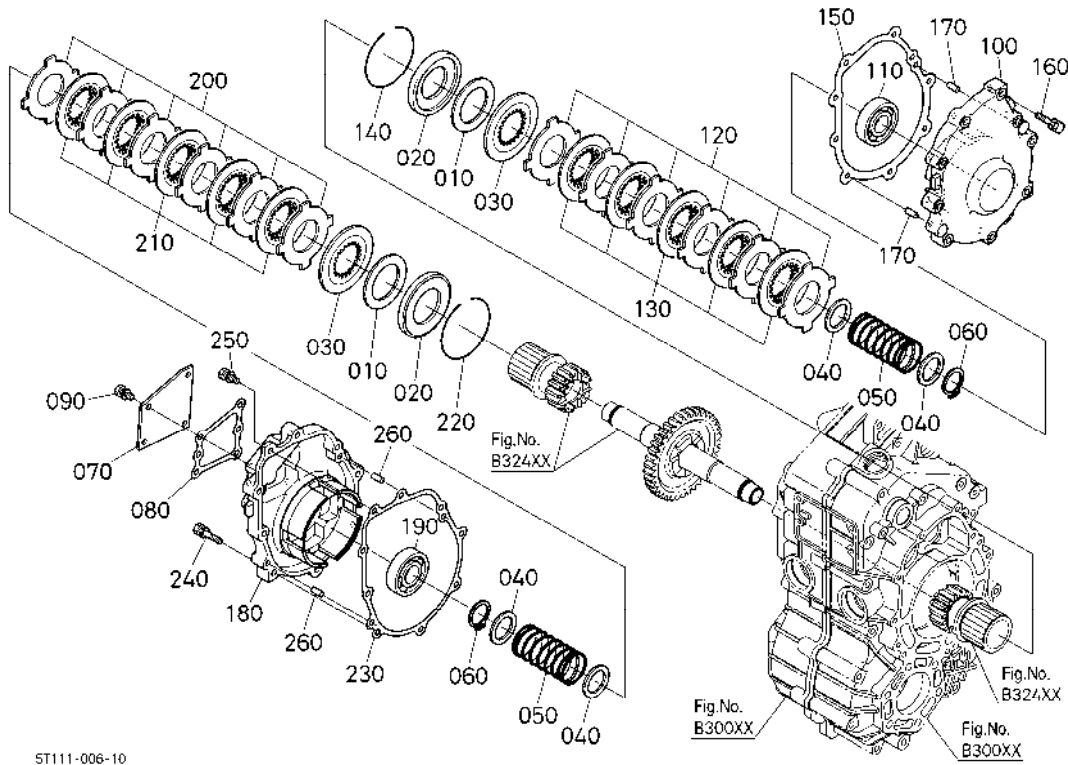

ST111-006-10

A:DC-68G HARVESKING

REF.No.	PART No.	PART NAME	Q'TY/S.No.	I.C.	REMARKS
			A		
010	5H844-1766-0	SPRING,PLATE	2		
020	5H844-1771-0	COLLAR	2		
030	5T070-1753-0	DISK,FRICTION	2		
040	5H852-1767-0	COLLAR	4		
050	5H852-1768-0	SPRING	2		
060	15451-9539-0	CIRCLIP,EXT	2		
070	5T110-1681-0	COVER(BRAKE)	1		
080	5T110-1682-0	GASKET	1		
090	01123-50820	BOLT,SEMS	4		
100	5T070-1663-0	CASE,BRAKE LH	1		
110	5T070-1635-0	BRNG,BALL(TM3/28)	1		
120	5T070-1743-0	PLATE(SEPARATOR)	6		
130	5T070-1744-0	DISK,FRICTION	5		
140	5T070-1755-0	STOPPER(PLATE)	1		
150	52270-1822-2	GASKET,CASE	1		
160	01123-50840	BOLT,SEMS	9		
170	05012-00818	PIN,STRAIGHT	2		
180	5T070-1664-0	CASE,BRAKE RH	1		
190	5T070-1635-0	BRNG,BALL(TM3/28)	1		
200	5T070-1743-0	PLATE(SEPARATOR)	6		
210	5T070-1744-0	DISK,FRICTION	5		
220	5T070-1755-0	STOPPER(PLATE)	1		
230	52270-1832-4	GASKET,CASE	1		
240	01123-50840	BOLT,SEMS	8		
250	01123-50825	BOLT,SEMS	1		
260	05012-00818	PIN,STRAIGHT	2		

↔ Interchangeable; ≠ not Interchangeable; ← new for old; → old for new

C10101 TRACK ROLLER LH

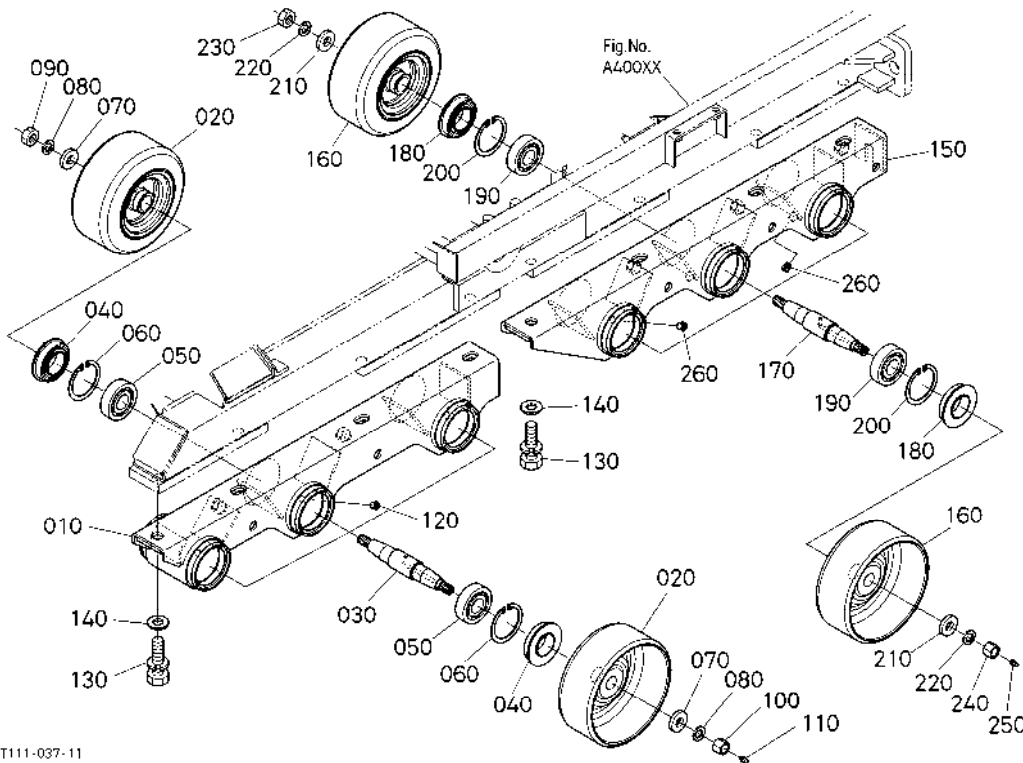

5T111-037-11

A:DC-68G HARVESKING

REF.No.	PART No.	PART NAME	Q'TY/S.No.	I.C.	REMARKS
			A		
010	5T111-2211-2	FRAME(TRACK,FRONT,L)	1		
020	5T111-2313-2	ROLLER(180W)	6		
030	5T111-2312-0	SHAFT(TRACK ROLLER)	3		
040	52200-2314-2	SEAL,OIL	6		
050	08101-06305	BEARING,BALL	6		
060	04611-00620	CIR-CLIP,INTERNAL	6		
070	5H601-2423-2	WASHER,PLAIN	6		
080	04512-50140	WASHER,SPRING LOCK	6		
090	02176-50140	HEX,NUT	3		
100	3F250-2736-0	NUT	3		
110	06613-10675	NIPPLE,GREASE	3		
120	T2050-8473-0	BLEEDER	3		
130	5T111-2314-0	BOLT	16		
140	04011-50160	WASHER,PLAIN	16		
150	5T111-2212-2	FRAME(TRACK,REAR,L)	1		
160	5T111-2313-2	ROLLER(180W)	6		
170	5T111-2312-0	SHAFT(TRACK ROLLER)	3		
180	52200-2314-2	SEAL,OIL	6		
190	08101-06305	BEARING,BALL	6		
200	04611-00620	CIR-CLIP,INTERNAL	6		
210	5H601-2423-2	WASHER,PLAIN	6		
220	04512-50140	WASHER,SPRING LOCK	6		
230	02176-50140	HEX,NUT	3		
240	3F250-2736-0	NUT	3		
250	06613-10675	NIPPLE,GREASE	3		
260	T2050-8473-0	BLEEDER	3		

↔ Interchangeable; ≠ not Interchangeable; ← new for old; → old for new

C10301 TENSION FRAME LH

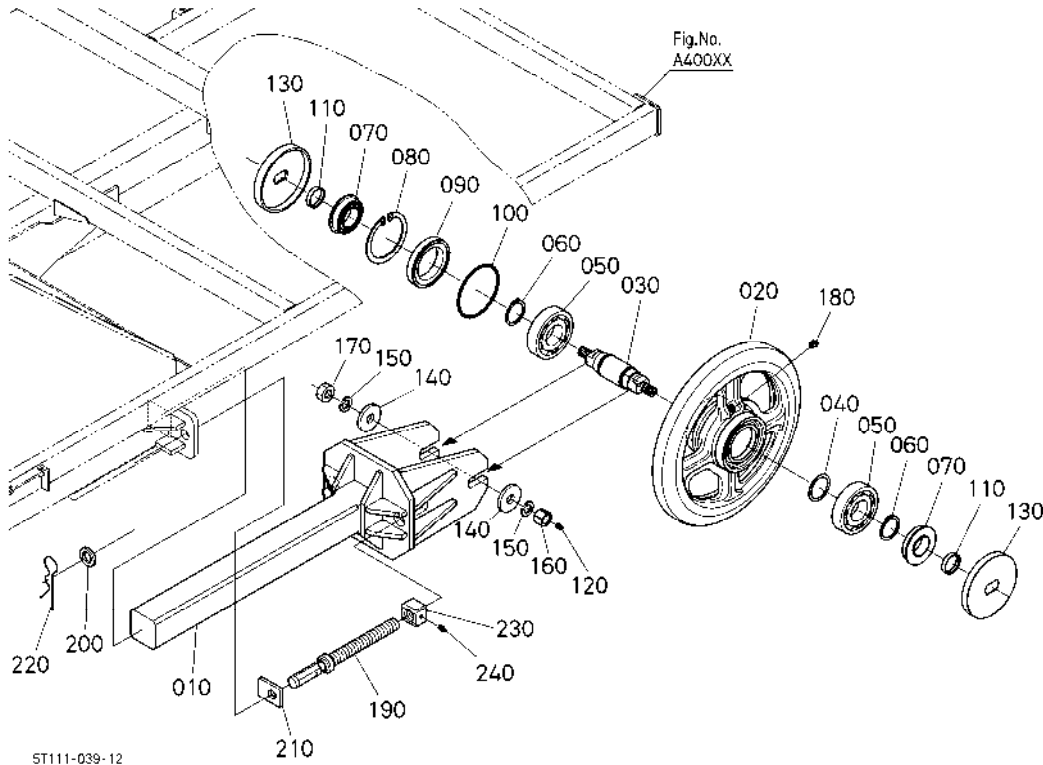

A:DC-68G HARVESKING

REF.No.	PART No.	PART NAME	Q'TY/S.No.	I.C.	REMARKS
			A		
010	5T111-2384-4	FRAME(TENSION)	1		
020	5T110-2388-2	ROLLER(340W)	1		
030	5T111-2385-3	SHAFT(REAR WHEEL)	1		
040	5T111-2396-0	COLLAR,THRUST	1		
050	08101-06308	BEARING,BALL	2		
060	04612-00400	CIR-CLIP,EXTERNAL	2		
070	52200-2314-2	SEAL,OIL	2		
080	04611-00900	CIR-CLIP,INTERNAL	1		
090	5T111-2386-0	COLLAR	1		
100	04810-50900	O RING	1		
110	5T111-2399-0	COLLAR,REAR WHEEL	2		
120	06613-10675	NIPPLE,GREASE	1		
130	5T111-2395-2	COVER(REAR WHEEL)	2		
140	51601-6218-0	WASHER,PLAIN	2		
150	04512-50160	WASHER,SPRING LOCK	2		
160	TC432-4939-0	HEX.NUT	1		
170	02174-50160	HEX.NUT	1		
180	T2050-8473-0	BLEEDER	1		
190	5T057-2215-0	BOLT,TENSION	1		
200	5T072-2995-0	WASHER	1		
210	5T111-2325-0	STOPPER	1		
220	05515-51600	PIN,SNAP	1		
230	5T111-2394-0	NUT(REAR WHEEL)	1		
240	06613-10675	NIPPLE,GREASE	1		

↔ Interchangeable; ≠ not Interchangeable; ← new for old; → old for new

C10302 TENSION FRAME RH

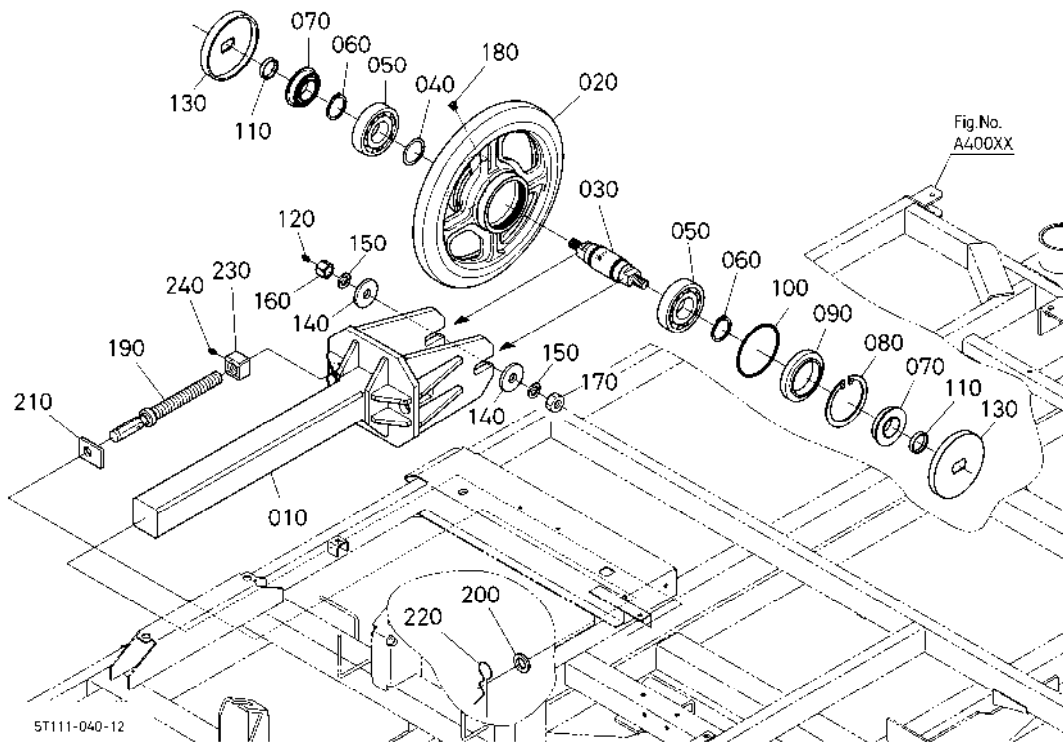

A:DC-68G HARVESKING

REF.No.	PART No.	PART NAME	Q'TY/S.No.	I.C.	REMARKS
			A		
010	5T111-2384-4	FRAME(TENSION)	1		
020	5T110-2388-2	ROLLER(340W)	1		
030	5T111-2385-3	SHAFT(REAR WHEEL)	1		
040	5T111-2396-0	COLLAR,THRUST	1		
050	08101-06308	BEARING,BALL	2		
060	04612-00400	CIR-CLIP,EXTERNAL	2		
070	52200-2314-2	SEAL,OIL	2		
080	04611-00900	CIR-CLIP,INTERNAL	1		
090	5T111-2386-0	COLLAR	1		
100	04810-50900	O RING	1		
110	5T111-2399-0	COLLAR,REAR WHEEL	2		
120	06613-10675	NIPPLE,GREASE	1		
130	5T111-2395-2	COVER(REAR WHEEL)	2		
140	51601-6218-0	WASHER,PLAIN	2		
150	04512-50160	WASHER,SPRING LOCK	2		
160	TC432-4939-0	HEX.NUT	1		
170	02174-50160	HEX.NUT	1		
180	T2050-8473-0	BLEEDER	1		
190	5T057-2215-0	BOLT,TENSION	1		
200	5T072-2995-0	WASHER	1		
210	5T111-2325-0	STOPPER	1		
220	05515-51600	PIN,SNAP	1		
230	5T111-2394-0	NUT(REAR WHEEL)	1		
240	06613-10675	NIPPLE,GREASE	1		

↔ Interchangeable; ≠ not Interchangeable; ← new for old; → old for new

D73100 HYDRAULIC UNIT(HARVEST) [COMPONENT PARTS]

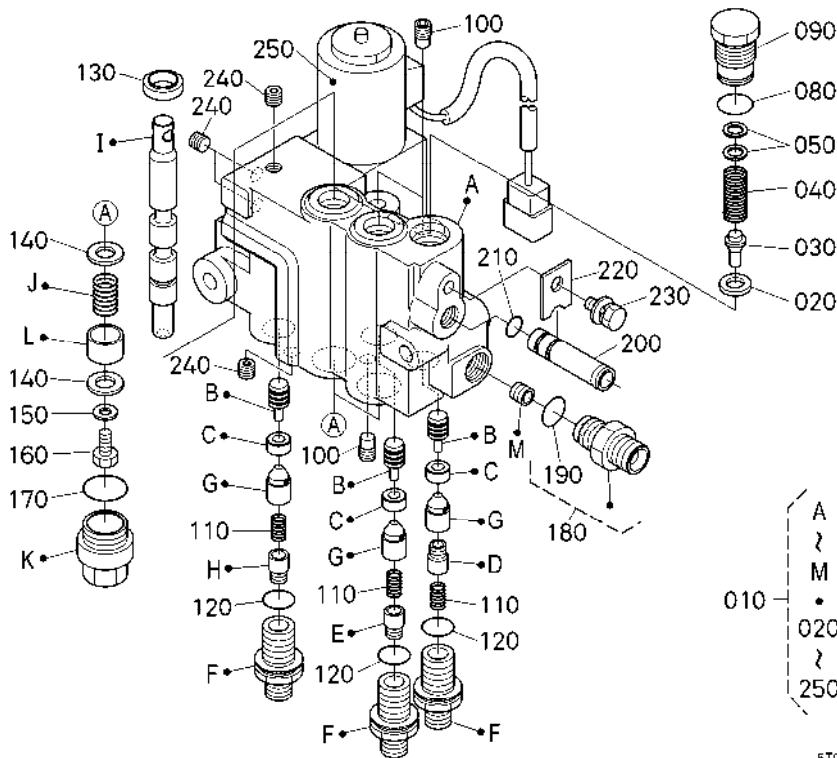

5T078-130-11

A:DC-68G HARVESKING

REF.No.	PART No.	PART NAME	Q'TY/S.No.	I.C.	REMARKS
			A		
010	YW600-0010-0	HYDRAULIC UNIT	1		
020	31351-3793-0	SEAT(RELIEF VALVE)	1		
030	YT450-0022-0	POPPET(RELIEF)	1		
040	31351-3792-0	SPRING(RELIEF)	1		
050	31351-3795-0	SHIM	2	0.4mm	
050	31351-3796-0	SHIM	2	0.2mm	
050	31351-3797-0	SHIM	2	0.1mm	
060	----	BLANK	-		
070	----	BLANK	-		
080	04817-05160	O RING	1		
090	YW226-0112-0	PLUG	1		
100	YT107-0048-0	PLUG	3		
110	YT082-5111-0	SPRING,CHECK	3		
120	04817-00160	O RING	3		
130	YW077-0061-0	SEAL,DUST	2		
140	04011-50100	WASHER,PLAIN	4		
150	04013-50060	WASHER, PLAIN	2		
160	01053-50612	HEX.BOLT	2		
170	04817-00220	O RING	2		
180	MR002-3031-0	JOINT,PIPE	1		
190	04817-00140	O RING	1		
200	YW315-0071-0	JOINT,T-PIPE	1		
210	04811-10090	O RING	1		
220	YW315-0072-0	STAY,DRAIN	1		
230	01025-50616	BOLT	1		
240	YT104-2101-0	PLUG	4		
250	YW226-0510-0	ASSY VALVE,SOLENOID	1		

↔ Interchangeable; ≠ not Interchangeable; ← new for old; → old for new

E21200 BRAKE PEDAL

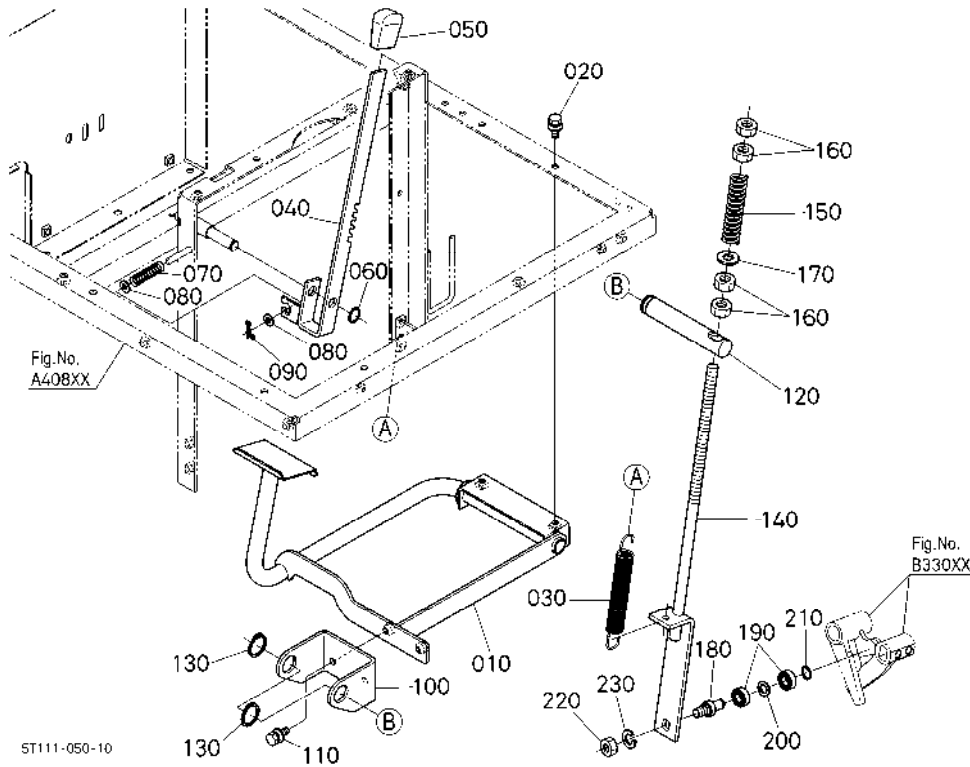

A:DC-68G HARVESKING

REF.No.	PART No.	PART NAME	Q'TY/S.No.	I.C.	REMARKS
			A		
010	5T078-3181-3	PEDAL,BRAKE	1		
020	01125-50820	BOLT,W SEMS	2		
030	5T078-3183-0	SPRING	1		
040	5T078-3185-2	LEVER(PEDAL LOCK)	1		
050	5T072-3128-0	GRIP	1		
060	04612-00140	CIR-CLIP	1		
070	70244-5638-0	SPRING	1		
080	04013-50080	WASHER,PLAIN	2		
090	TC402-3412-0	PIN,SNAP	1		
100	5T111-3184-0	STAY(BRAKE)	1		
110	01125-50820	BOLT,W SEMS	2		
120	5T078-3182-0	PIN,BRAKE	1		
130	04612-00250	CIR-CLIP,EXTERNAL	2		
140	5T078-3188-0	ROD(BRAKE)	1		
150	5T078-3189-0	SPRING	1		
160	02174-50140	HEX.NUT	4		
170	04011-50140	WASHER,PLAIN	1		
180	5T078-3186-0	SHAFT,BRAKE	1		
190	08141-06001	BALL BEARING	2		
200	5T078-3191-0	WASHER	1		
210	04612-00120	CIR-CLIP EXTERNAL	1		
220	02174-50120	HEX.NUT	1		
230	04512-50120	WASHER,SPRING LOCK	1		

↔ Interchangeable; ≠ not Interchangeable; ← new for old; → old for new

E21400 HARVEST CLUTCH LEVER

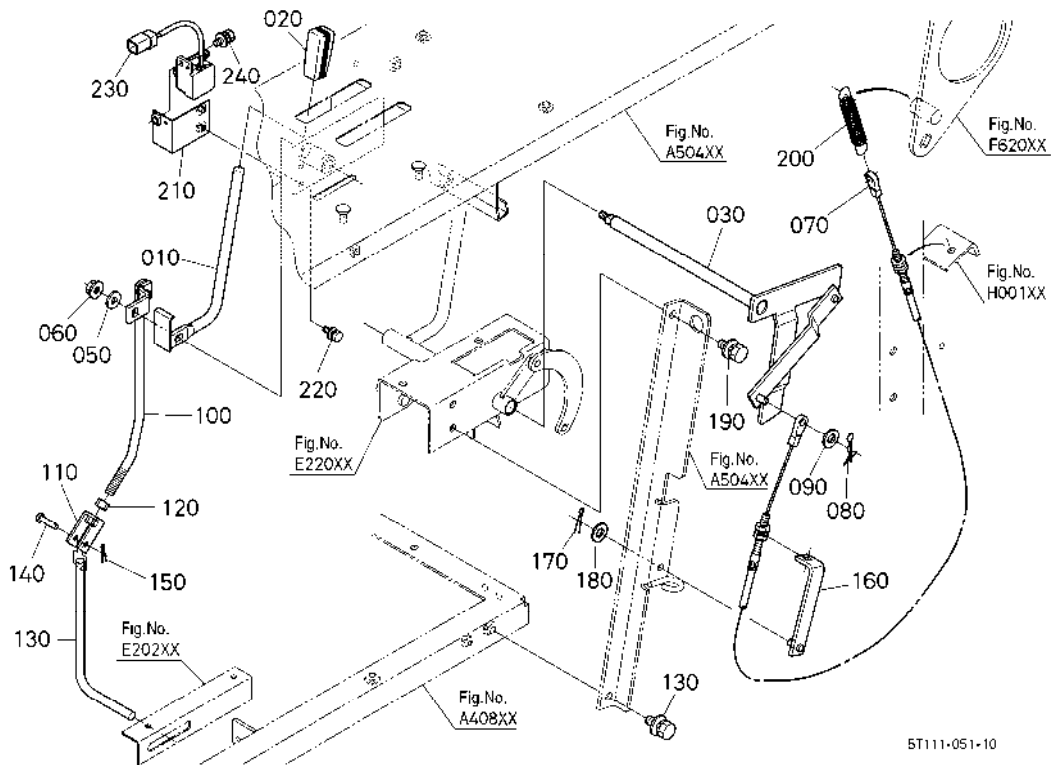

5T111-051-10

A:DC-68G HARVESKING

REF.No.	PART No.	PART NAME	Q'TY/S.No.	I.C.	REMARKS
			A		
010	5T078-3251-0	LEVER	1		
020	55611-3145-0	GRIP,LEVER	1		
030	5T111-3253-0	ROD(HARVE.FULCRUM)	1		
040	---	BLANK	1		
050	04015-50080	WASHER,PLAIN	1		
060	02751-50080	NUT,FLANGE	1		
070	5T070-3254-3	CABLE,CUTTER CRUTCH	1		
080	TC402-3412-0	PIN,SNAP	1		
090	04013-50080	WASHER,PLAIN	1		
100	5T111-3255-0	ROD	1		
110	5T111-3258-0	END,ROD(CHECK)	1		
120	02118-50100	HEX.NUT	1		
130	5T111-3256-0	ROD	1		
140	05122-50625	PIN,JOINT	1		
150	05511-51615	PIN,SPLIT	1		
160	5T072-3236-0	ARM,REAPER CLUTCH	1		
170	05511-50215	PIN,SPLIT	1		
180	04013-50080	WASHER,PLAIN	1		
190	01125-50820	BOLT,W SEMS	2		
200	5T072-3322-0	SPRING,HARVEST	1		
210	5T078-3259-0	STAY(FAN SW)	1		
220	01025-50616	BOLT	2		
230	5G127-7127-0	SWITCH	1		
240	01025-50616	BOLT	1		

↔ Interchangeable; ≠ not Interchangeable; ← new for old; → old for new

F53000 BLADE REAPING

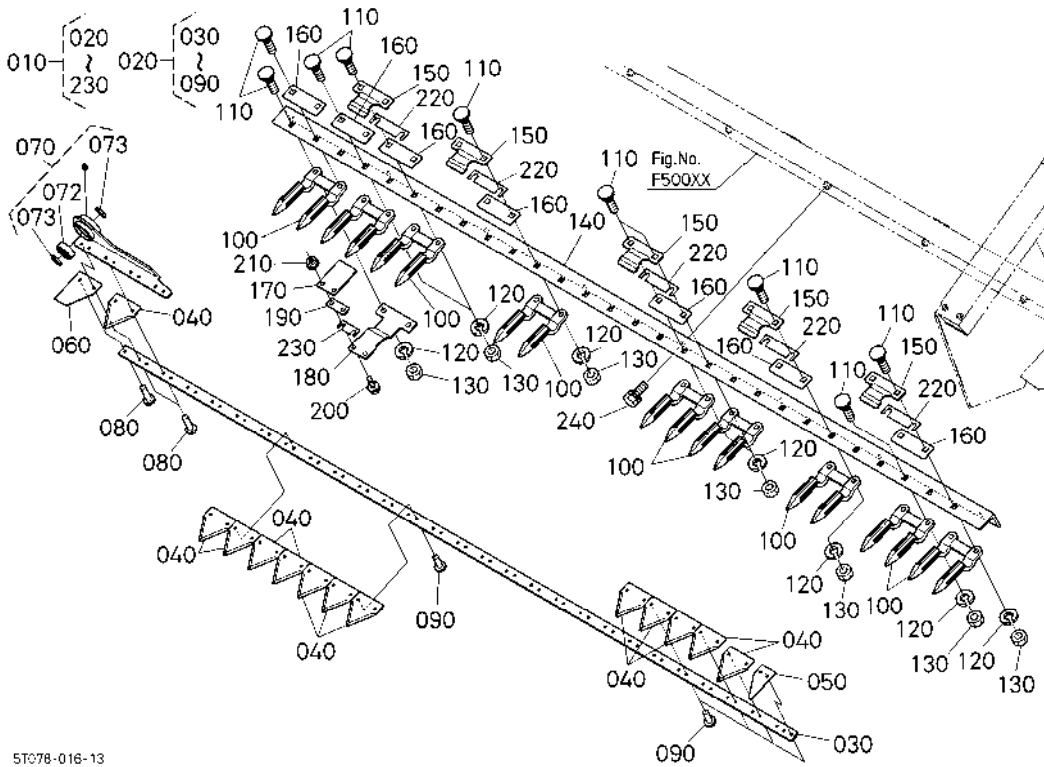

5T078-016-13

A:DC-68G HARVESKING-REEL/FEEDER

REF.No.	PART No.	PART NAME	Q'TY/S.No.	I.C.	REMARKS
			A		
010	5T079-5130-0	BLADE,REAPING,ASSY	1		
020	5T079-5131-0	BLADE,REAPING,COMP	1		
030	5T078-5132-0	KNIFE BAR	1		
040	5T072-5133-0	CUTTING BLADE	26		
050	5T072-5134-0	PLATE	1		
060	5T072-5135-0	PLATE	1		
070	5T072-5136-0	HEAD,KNIFE	1		
072	08141-06302	BEARING,BALL	1		
073	04611-00420	CIR-CLIP,INTERNAL	2		
080	5T072-5137-0	RIVET	8		
090	5T072-5138-0	RIVET	48		
100	5T072-5141-0	GUARD,KNIFE	14		
110	5T072-5142-0	BOLT,SQ.NECK	28		
120	04512-50100	WASHER,SPRING LOCK	28		
130	02114-50100	HEX.NUT	28		
140	5T078-5143-0	BASE	1		
150	5T072-5144-0	CLIP,KNIFE	5		
160	5T072-5145-0	GUIDE,SLIDE	7		
170	5T072-5146-0	KNIFE CLIP,RH	1		
180	5T072-5147-0	SUPPORT	1		
190	5T072-5148-0	SPACER	1		
200	01754-50825	BOLT,FLANGE	2		
210	02751-50080	NUT,FLANGE	2		
220	5T072-5149-0	SHIM	5		
230	5T072-5151-0	SPACER	1		
240	01133-51025	BOLT,SEMS	8		

↔ Interchangeable; ≠ not Interchangeable; ← new for old; → old for new

F54000 AUGER DRUM

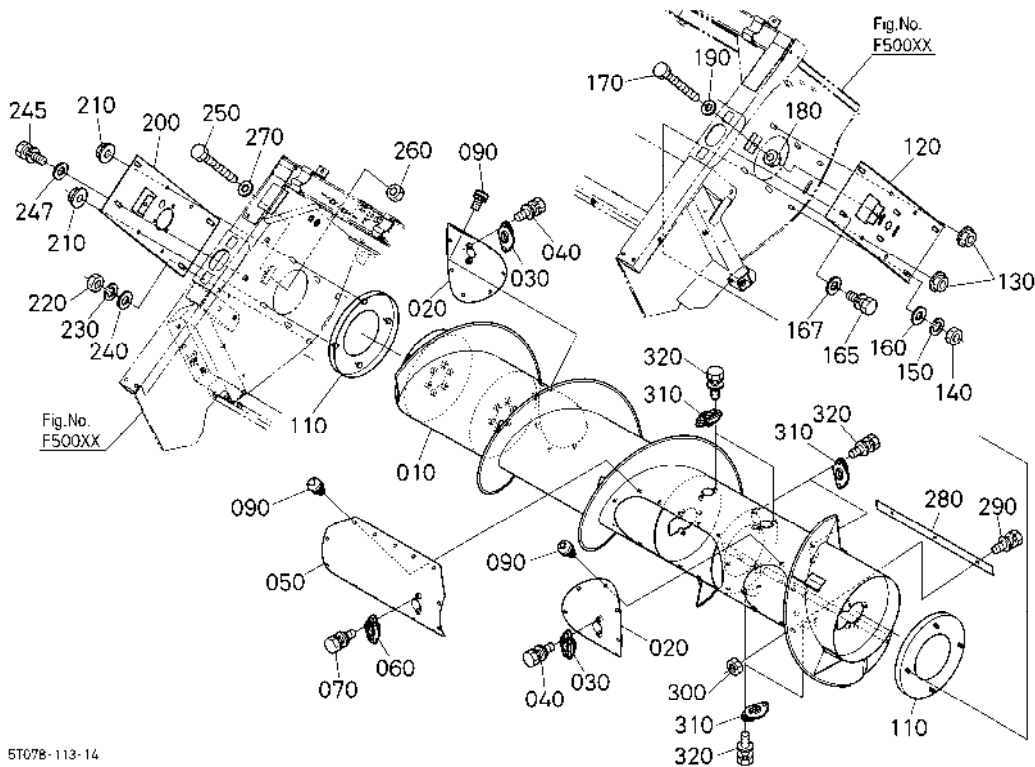

5T078-113-14

A:DC-68G HARVESKING-REEL/FEEDER

REF.No.	PART No.	PART NAME	Q'TY/S.No.	I.C.	REMARKS
			A		
010	5T078-5211-4	DRUM,AUGER	1		
020	5T072-5212-3	COVER,DRUM	2		
030	5T072-5245-0	GUIDE	2		
040	01125-50820	BOLT,W SEMS	4		
050	5T072-5214-4	COVER,DRUM 2	1		
060	5T072-5245-0	GUIDE	1		
070	01125-50820	BOLT,W SEMS	2		
080	----	BLANK	-		
090	5T072-5219-2	SCREW,RD MACH.(CROSS	30		
100	----	BLANK	-		
110	5T072-5215-0	GUIDE,DRUM	2		
120	5T072-5216-0	STAY,DRUM LH	1		
130	02131-50100	NUT	4		
140	02118-50100	HEX.NUT	2		
150	04512-50100	WASHER,SPRING LOCK	2		
160	04015-50100	WASHER,PLAIN	2		
165	01133-51020	BOLT,SEMS	2		
167	04015-50100	WASHER,PLAIN	2		
170	01155-50855	HEX.BOLT	1		
180	02114-50080	HEX.NUT	1		
190	04013-50080	WASHER,PLAIN	1		
200	5T072-5217-0	STAY,DRUM RH	1		
210	02131-50100	NUT	4		
220	02118-50100	HEX.NUT	2		
230	04512-50100	WASHER,SPRING LOCK	2		
240	04015-50100	WASHER,PLAIN	2		
245	01133-51020	BOLT,SEMS	2		
247	04015-50100	WASHER,PLAIN	2		
250	01155-50855	HEX.BOLT	1		
260	02114-50080	HEX.NUT	1		

↔ Interchangeable; ≠ not Interchangeable; ← new for old; → old for new

F54500 AUGER DRUM SHAFT

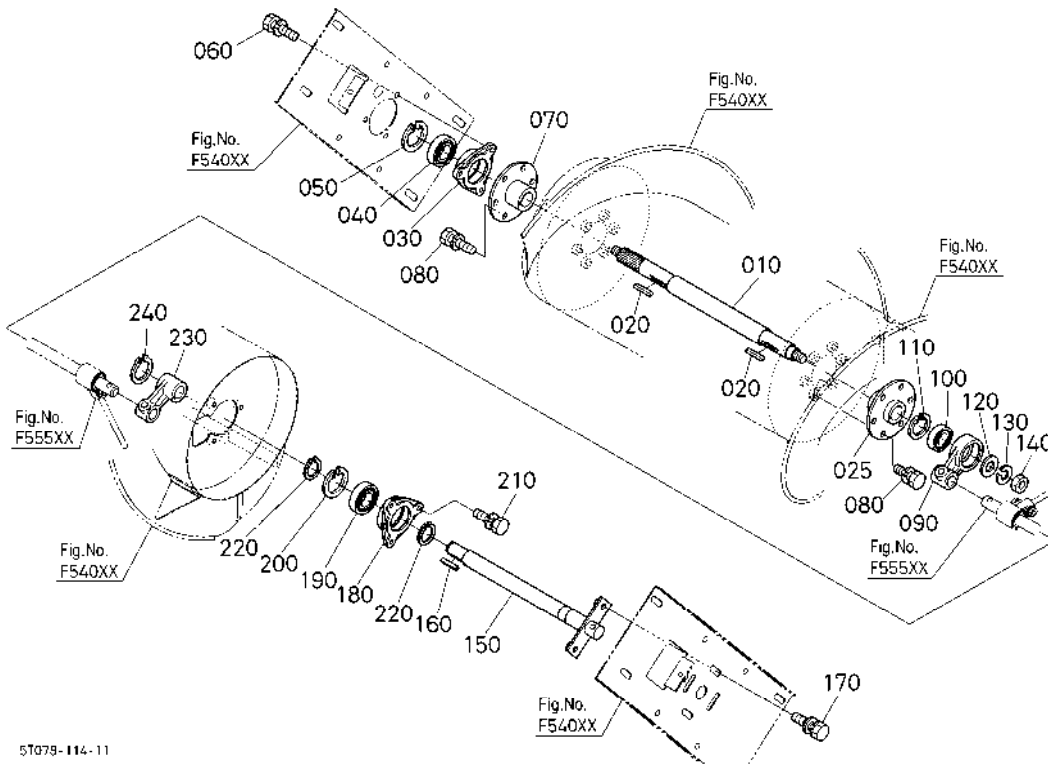

5T079-114-11

A:DC-68G HARVESKING-REEL/FEEDER

REF.No.	PART No.	PART NAME	Q'TY/S.No.	I.C.	REMARKS
			A		
010	5T072-5221-0	SAHFT,AUGER DRIVE	1		
020	5T072-5229-0	KEY,WOODRUFF	2		
025	5T072-5224-0	BOSS,DRUM DRIVE	1		
030	5T072-5222-0	BRACKET,SHAFT	1		
040	08141-06206	BEARING,BALL	1		
050	04611-00620	CIR-CLIP,INTERNAL	1		
060	01123-51020	BOLT,SEMS	3		
070	5T072-5224-0	BOSS,DRUM DRIVE	1		
080	01133-51020	BOLT,SEMS	12		
090	5T072-5225-0	BRACKET,CRANK	1		
100	08141-06205	BEARING,BALL	1		
110	04611-00520	CIR-CLIP,INTERNAL	1		
120	04011-50180	WASHER,PLAIN	1		
130	04512-50180	WASHER,SPRING LOCK	1		
140	02172-50180	HEX.NUT	1		
150	5T078-5231-0	SHAFT,FIXING	1		
160	05712-00735	KEY,FEATHER	1		
170	01135-51025	BOLT,W SEMS	4		
180	5T072-5232-0	BRACKET,SHAFT	1		
190	08141-06206	BEARING,BALL	1		
200	04611-00620	CIR-CLIP,INTERNAL	1		
210	01123-50825	BOLT,SEMS	3		
220	04612-00300	CIR-CLIP,EXTERNAL	2		
230	5T072-5234-0	BRACKET,CRANK	1		
240	04612-00250	CIR-CLIP,EXTERNAL	1		

↔ Interchangeable; ≠ not Interchangeable; ← new for old; → old for new

F55000 AUGER DRUM CHAIN

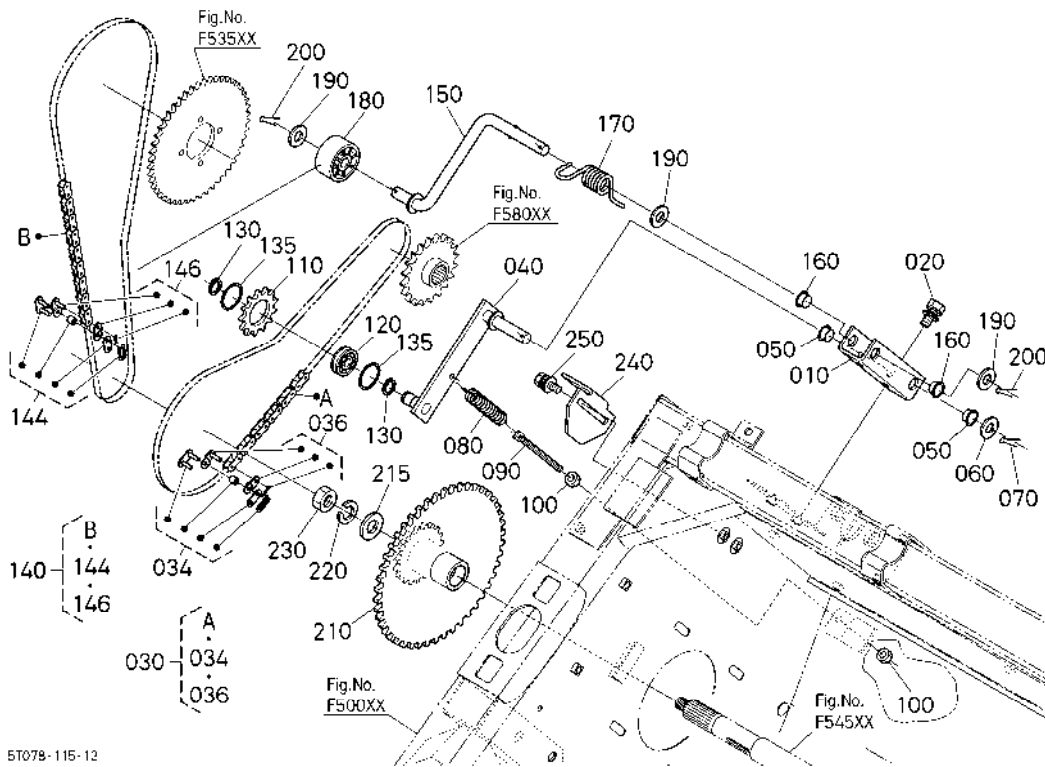

5T078-115-12

A:DC-68G HARVESKING-REEL/FEEDER

REF.No.	PART No.	PART NAME	Q'TY/S.No.	I.C.	REMARKS
			A		
010	5T072-4921-0	BASE,TENSION	1		
020	01135-51020	BOLT,W SEMS	2		
030	5T077-4930-0	ASSY CHAIN,AUGER	1		
034	5T051-4645-0	HOLDER,CHAIN	1		
036	5T051-4931-0	JOINT,CHAIN OFF SET	1		
040	5T072-4933-0	TENSION ARM,AUGER	1		
050	T2050-2416-0	BUSH	2		
060	04011-50160	WASHER,PLAIN	1		
070	05511-50430	PIN,SPLIT	1		
080	5T072-4642-0	SPRING	1		
090	5T072-1635-0	BOLT,TENSION	1		
100	02114-50080	HEX.NUT	2		
110	5T072-4636-0	SPROCKET,TENSION	1		
120	5T070-4637-0	BEARING	1		
130	04612-00170	CIR-CLIP,EXTERNAL	2		
135	5T070-4638-0	CIR CLIP	2		
140	5T077-4940-0	ASSY CHAIN,COUNTER	1		
144	5T051-4941-0	HOLDER,CHAIN	1		
146	5T051-4942-0	JOINT,CHAIN OFF SET	1		
150	5T072-4943-0	ARM,TENSION	1		
160	T2050-2416-0	BUSH	2		
170	5T072-4944-0	SPRING,COUNTER	1		
180	5T072-4935-0	ROLLER,TENSION	1		
190	04011-50160	WASHER,PLAIN	3		
200	05511-50430	PIN,SPLIT	2		
210	5T078-5228-0	SPROCKET	1		46-19T
215	04013-50180	WASHER,PLAIN	1		
220	04512-50180	WASHER,SPRING LOCK	1		
230	02172-50180	HEX.NUT	1		
240	5T072-4945-0	STOPPER	1		

↔ Interchangeable; ≠ not Interchangeable; ← new for old; → old for new

F61000 HARVEST DRIVE CHAIN

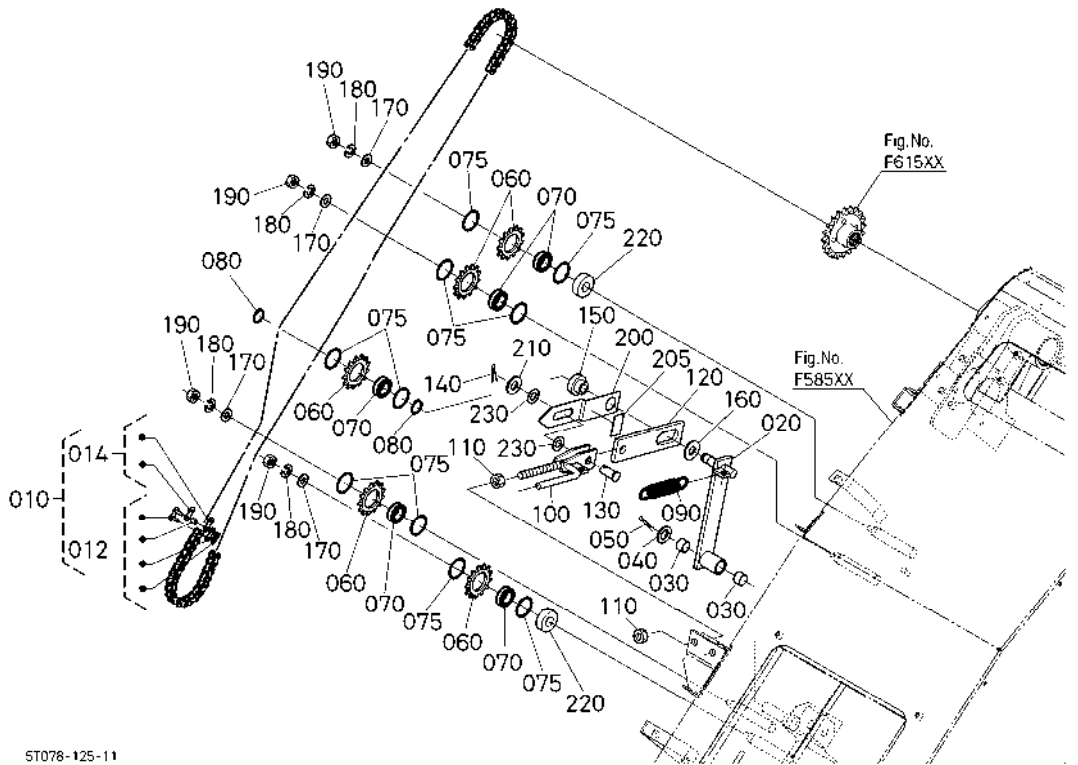

ST078-125-11

A:DC-68G HARVESKING-REEL/FEEDER

REF.No.	PART No.	PART NAME	Q'TY/S.No.	I.C.	REMARKS
			A		
010	5T051-4640-0	ASSY CHAIN	1		
012	5T051-4645-0	HOLDER,CHAIN	2		
014	5T051-4646-0	CHAIN,ROLLER LINK	1		
020	5T078-5631-0	ARM,TENSION	1		
030	5T057-1085-0	BUSH	2		
040	04011-50200	WASHER,PLAIN	1		
050	05511-50435	PIN,SPLIT	1		
060	5T072-4636-0	SPROCKET,TENSION	5		
070	5T070-4637-0	BEARING	5		
075	5T070-4638-0	CIR CLIP	10		
080	04612-00170	CIR-CLIP,EXTERNAL	2		
090	5T078-4642-0	SPRING,TENSION	1		
100	5T078-5632-0	BOLT,TENSION	1		
110	02174-50140	HEX.NUT	2		
120	5T078-5633-0	INTERLOCKER	1		
130	05122-51645	PIN,JOINT	1		
140	05511-50430	PIN,SPLIT	1		
150	5T078-5634-0	COLLAR	1		
160	5T078-5635-0	SPACER	1		
170	04013-50100	WASHER,PLAIN	4		
180	04512-50100	WASHER,SPRING LOCK	4		
190	02118-50100	HEX.NUT	4		
200	5T078-5636-0	GAUGE,TENSION	1		
205	5T078-5637-0	RUBBER,GAUGE	1		
210	04011-50160	WASHER,PLAIN	1		
220	5T078-4638-0	ROLLER CAP	2		
230	5T078-5638-0	CUSHION,GAUGE	2		

↔ Interchangeable; ≠ not Interchangeable; ← new for old; → old for new

F61500 FEEDER DRIVE SHAFT

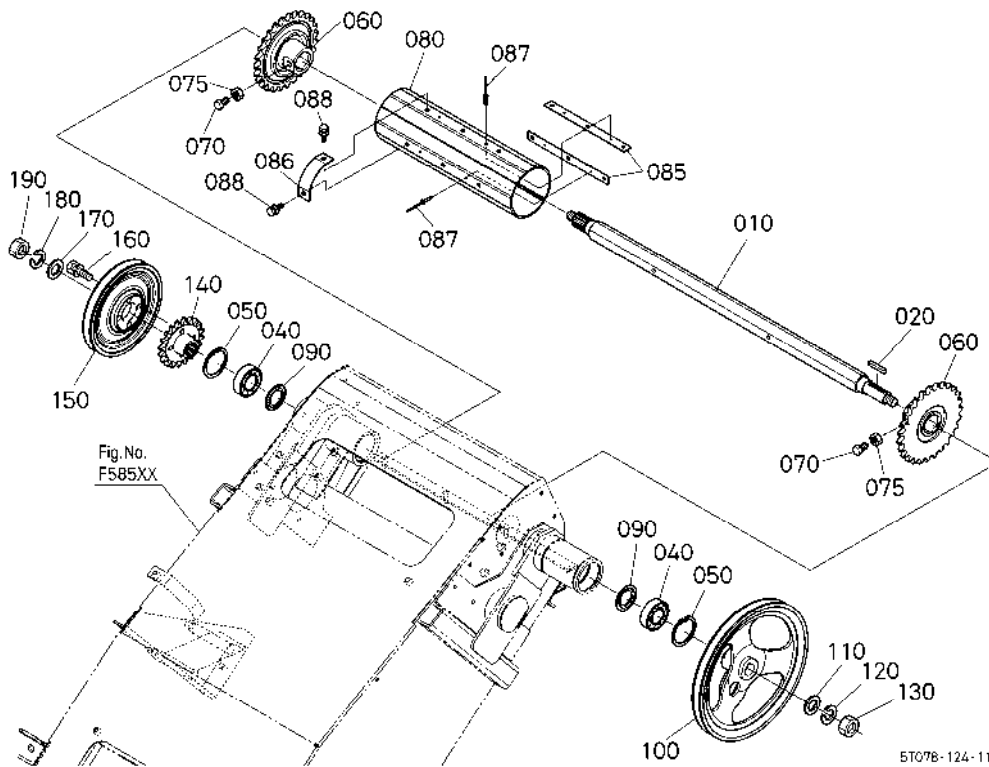

A:DC-68G HARVESKING-REEL/FEEDER

REF.No.	PART No.	PART NAME	Q'TY/S.No.	I.C.	REMARKS
			A		
010	5T078-4611-4	SHAFT(FEEDER)	1		
020	05712-00745	KEY,FEATHER	1		
030	---	BLANK	1		
040	08141-06206	BEARING,BALL	2		
050	04611-00620	CIR-CLIP,INTERNAL	2		
060	5T078-4612-3	SPROCKET 27	2		
070	5T078-4613-0	SCREW,SPROCKET	2		
075	02072-50120	NUT	2		
080	5T091-4661-0	COVER,FEEDER-SHAFT	1		
085	5T078-4624-0	PLATE,NUT	2		
086	5T078-4625-0	STAY(COVER)	3		
087	5T078-4626-0	RIVET	4		
088	01025-50620	BOLT	6		
090	5T078-4617-2	COVER,DUSTPROOF	2		
100	5T078-4621-2	PULLEY,V300	1		
110	04011-50180	WASHER,PLAIN	1		
120	04512-50180	WASHER,SPRING LOCK	1		
130	02172-50180	HEX.NUT	1		
140	5T078-5621-0	SPROCKET	1		
150	5T078-5623-0	PULLEY,V	1		
160	01133-51035	BOLT,SEMS	4		
170	04011-50180	WASHER,PLAIN	1		
180	04512-50180	WASHER,SPRING LOCK	1		
190	02172-50180	HEX.NUT	1		

↔ Interchangeable; ≠ not Interchangeable; ← new for old; → old for new

H00101 THRESHING FRAME(UPPER)

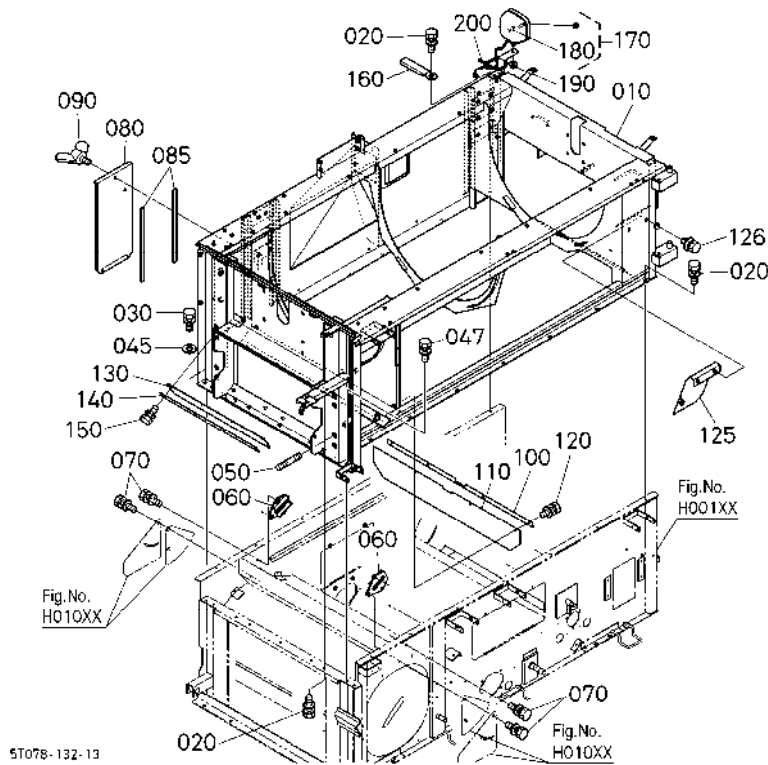

A:DC-68G HARVESKING-THRESHING

REF.No.	PART No.	PART NAME	Q'TY/S.No.	I.C.	REMARKS
			A		
010	5T078-6102-2	FRAME,COMP(UPPER)	1		
020	01125-50820	BOLT,W SEMS	19		
030	01138-51030	BOLT,SEMS	2		
040	---	BLANK	-		
045	04013-50100	WASHER,PLAIN	2		
047	01135-51025	BOLT,W SEMS	2		
050	01517-51640	BOLT,STUD	2		
060	5T078-6951-0	GUIDE(SIEVE)	2		
070	01125-50820	BOLT,W SEMS	6		
080	5T072-6193-0	COVER(RH,SIDE)	1		
085	5T072-6194-0	SEAL(COVER,RH)	2		
090	01811-50812	BOLT,WING	1		
100	5T072-6213-0	RETAINER(SEAL,FRT FR	1		
110	5T057-6214-0	CLOTH,FRAME FRONT	1		
120	01025-50616	BOLT	4		
125	5T078-6221-0	PLATE(THROWER)	1		
126	01125-50820	BOLT,W SEMS	3		
130	5T072-6387-0	CLOTH	1		
140	5T072-6388-0	RETAINER(SEAL,FEEDER	1		
150	01025-50620	BOLT	4		
160	5H400-2591-0	CLAMP,CORD	1		
170	5H484-3138-2	ASSY LAMP,ELECTRIC	1		
180	5H484-3139-2	BULB	1	55W	
190	02121-50080	NUT	1		
200	5T072-4126-0	CORD(BAND)	1		

↔ Interchangeable; ≠ not Interchangeable; ← new for old; → old for new

H01600 THRESHING BONNET

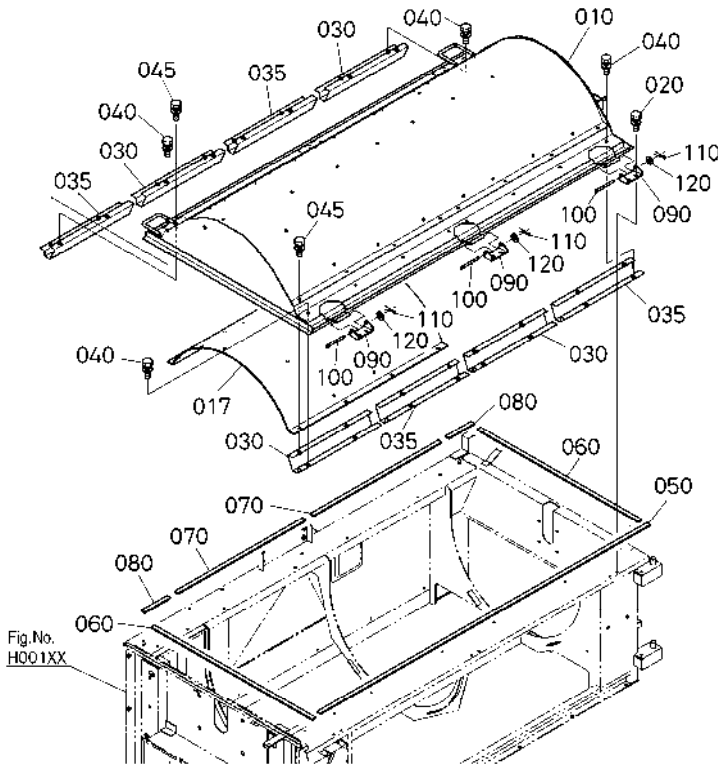

A:DC-68G HARVESKING-THRESHING

REF.No.	PART No.	PART NAME	Q'TY/S.No.	I.C.	REMARKS
			A		
010	5T078-6411-0	COVER,T-CYL.	1		
017	5T078-6414-0	PLATE	1		
020	01125-50820	BOLT,W SEMS	6		
030	5T078-6412-0	PLATE(BONNET)	4		
035	5T078-6415-0	PLATE(BONNET)	4		
040	01125-50820	BOLT,W SEMS	24		
045	01125-50820	BOLT,W SEMS	8		
050	5T078-6416-0	SEAL	1		
060	5T072-6417-0	SPONGE,BONNET	2		
070	5T078-6426-0	SPONGE,BONNET	2		
080	5T072-6427-0	SPONGE,BONNET	2		
090	5T072-6415-0	STAY(BONNET)	3		
100	5T072-6425-0	PIN(JOINT,8×L90)	3		
110	05511-50215	PIN,SPLIT	3		
120	04013-50080	WASHER,PLAIN	3		

↔ Interchangeable; ≠ not Interchangeable; ← new for old; → old for new

H01800 DUST CARRYING VALVE

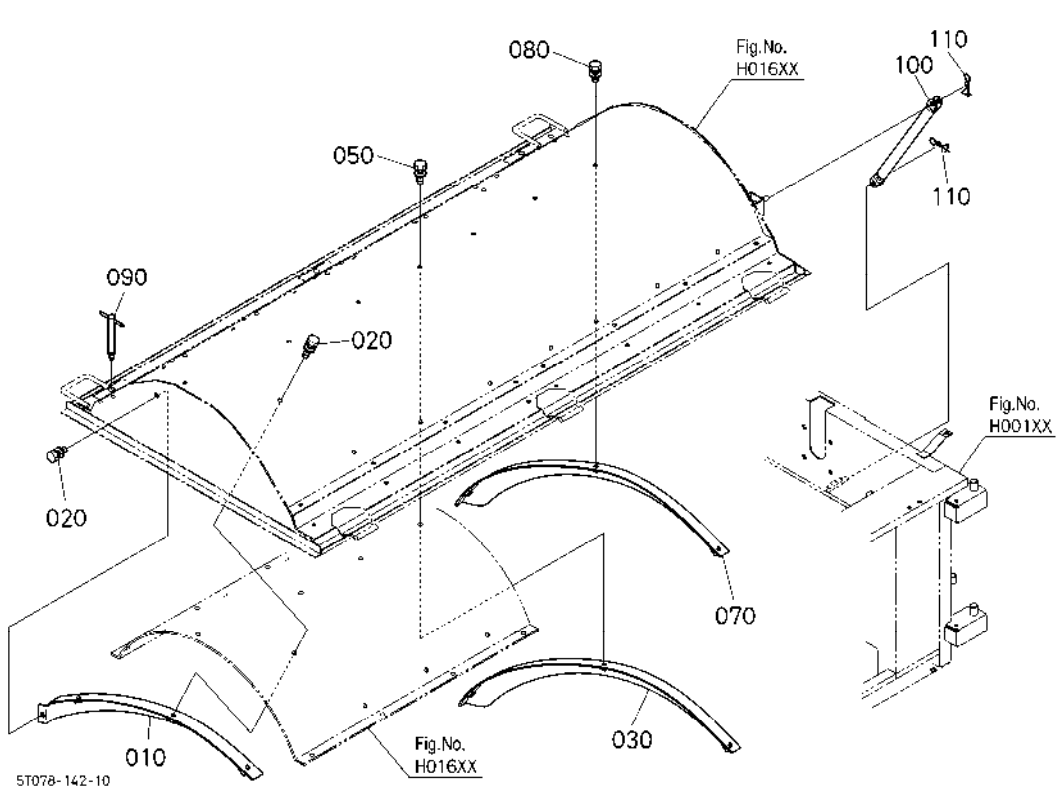

A:DC-68G HARVESKING-THRESHING

REF.No.	PART No.	PART NAME	Q'TY/S.No.	I.C.	REMARKS
			A		
010	5T072-6421-0	PLATE	1		
020	01125-50820	BOLT,W SEMS	4		
030	5T072-6422-0	PLATE	3		
040	----	BLANK	-		
050	01125-50820	BOLT,W SEMS	9		
060	----	BLANK	-		
070	5T072-6423-0	PLATE	3		
080	01125-50820	BOLT,W SEMS	9		
090	5T072-6418-2	BOLT(JACK)	3		
100	5T051-6420-0	DAMPER,GAS	1		
110	5T072-6429-0	SNAP PIN	2		

↔ Interchangeable; ≠ not interchangeable; ← new for old; → old for new

H21000 OPEN-CLOSE COVER

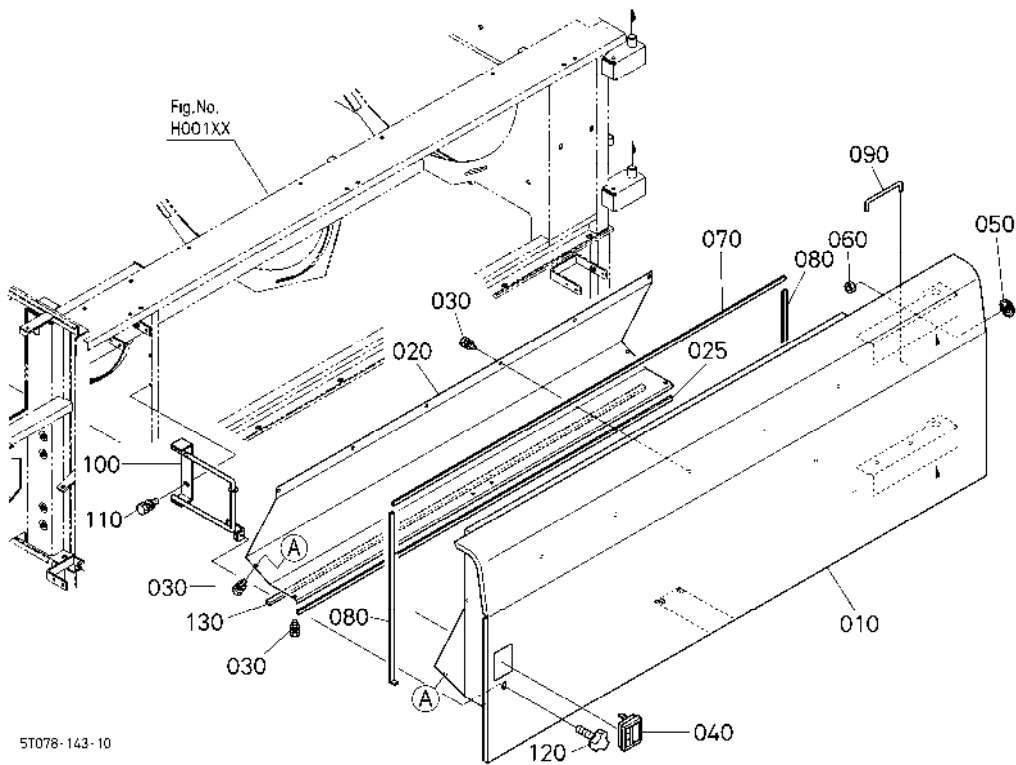

A:DC-68G HARVESKING-THRESHING

REF.No.	PART No.	PART NAME	Q'TY/S.No.	I.C.	REMARKS
			A		
010	5T078-7211-0	COVER(OPEN-CLOSE)	1		
020	5T078-7212-0	PLATE(COVER)	1		
025	5T078-7219-0	SEAL(COVER)	1		
030	01025-50616	BOLT	12		
040	5T072-6136-0	ASSY HANDLE	1		
050	5T072-7214-0	REFLECTOR	1		
060	02021-50050	NUT	1		
070	5T078-7215-0	SEAL(42)	1		
080	5T072-7216-0	SEAL(42)	2		
090	5T078-7213-0	ROD(OPEN)	1		
100	5T072-7217-0	STAY,COVER OPEN	1		
110	01125-50820	BOLT,W SEMS	2		
120	01820-50815	BOLT,KNOB	1		
130	5T078-7219-0	SEAL(COVER)	1		

↔ Interchangeable; ≠ not Interchangeable; ← new for old; → old for new

H21200 THRESHING COVER(FRONT/BACK)

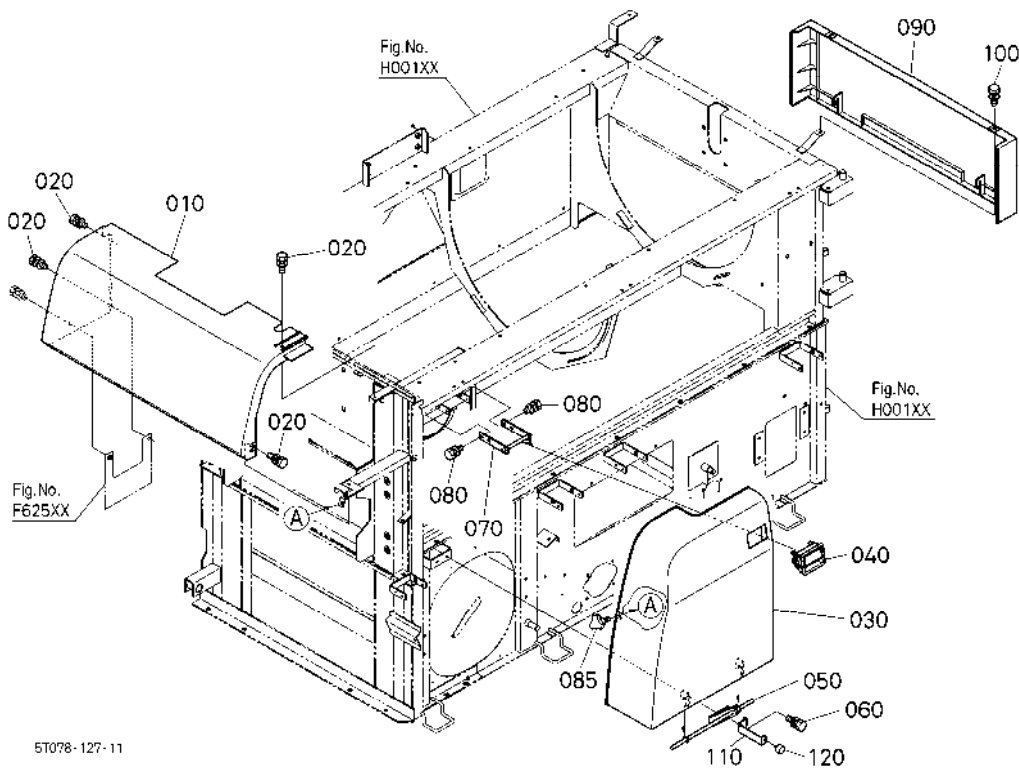

A:DC-68G HARVESKING-THRESHING

REF.No.	PART No.	PART NAME	Q'TY/S.No.	I.C.	REMARKS
			A		
010	5T072-7221-2	COVER(FRT,1)	1		
020	01127-50820	BOLT,W SEMS(LARGE WA	4		
030	5T072-7222-2	COVER(FRT,2)	1		
040	5T072-6136-0	ASSY HANDLE	1		
050	5T072-7223-0	STAY,COVER UPPER	1		
060	01125-50825	BOLT,W SEMS	2		
070	5T072-7225-0	STAY,COVER SIDE	1		
080	01025-50616	BOLT	2		
085	01820-50615	BOLT,KNOB	1		
090	5T072-7241-2	COVER(REAR)	1		
100	01127-50820	BOLT,W SEMS(LARGE WA	2		
110	5T078-7235-0	PLATE	1		
120	5T051-5919-0	CUSHION	1		

↔ Interchangeable; ≠ not Interchangeable; ← new for old; → old for new

H22000 WINNOWER SHAFT

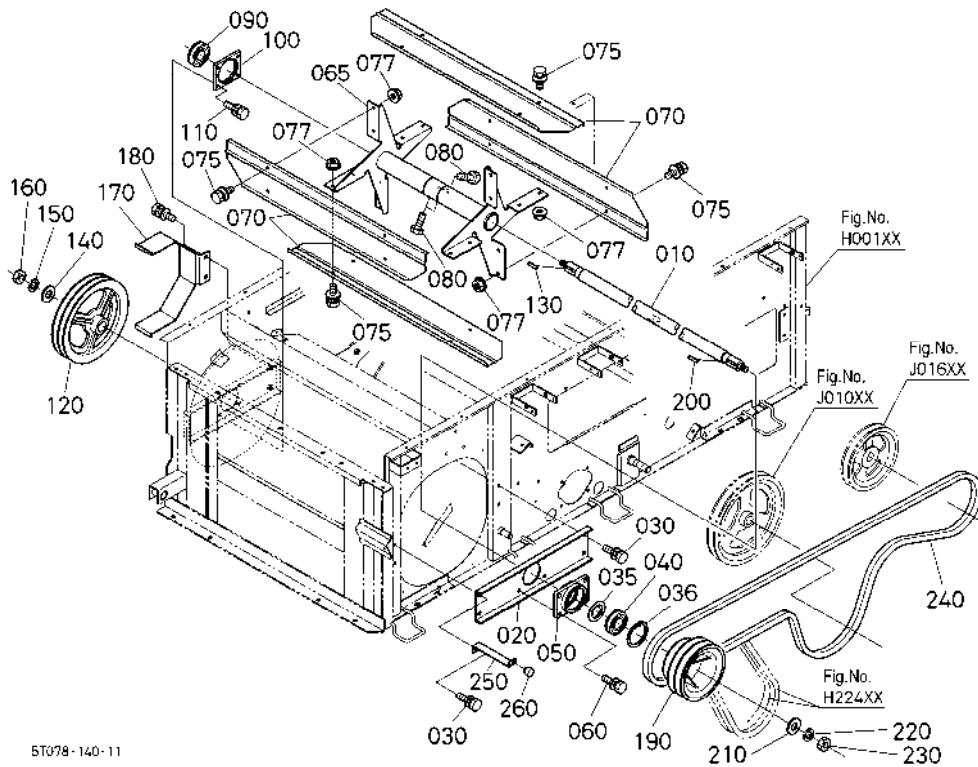

5T078-140-11

A:DC-68G HARVESKING-THRESHING

REF.No.	PART No.	PART NAME	Q'TY/S.No.	I.C.	REMARKS
			A		
010	5T078-6611-0	SHAFT(FAN)	1		
020	5T078-6613-2	PLATE(FAN)	1		
030	01133-51020	BOLT,SEMS	4		
035	5T078-6634-0	COVER,DUST	1		
036	04611-00720	CIR-CLIP,INTERNAL	1		
040	5T076-6624-0	BEARING	1		
050	5T078-6615-2	HOLDER(BEARING,1)	1		
060	01133-51030	BOLT,SEMS	4		
065	5T078-6623-0	ARM(WINNOWER)	1		
070	5T072-6619-0	BLADE(FAN)	4		
075	01127-50820	BOLT,W SEMS(LARGE WA	16		
077	02751-50080	NUT,FLANGE	16		
080	01173-51020	HEX.BOLT	4		
090	5T050-6621-0	BEARING	1		
100	5T078-6622-0	HOLDER	1		
110	01133-51020	BOLT,SEMS	4		
120	5T078-6631-0	V PULLEY	1		
130	05712-00735	KEY,FEATHER	1		
140	5T072-6519-0	WASHER,PLAIN	1		
150	04512-50160	WASHER,SPRING LOCK	1		
160	02174-50160	HEX.NUT	1		
170	5T078-6632-0	GUIDE(THRESHER,INLET	1		
180	01125-50820	BOLT,W SEMS	2		
190	5T078-6633-2	V-PULLEY(C2*177-B136)	1		
200	05712-00735	KEY,FEATHER	1		
210	5T072-6519-0	WASHER,PLAIN	1		
220	04512-50160	WASHER,SPRING LOCK	1		
230	02174-50160	HEX.NUT	1		
240	5T078-6635-0	V BELT,THRESHER	1		
250	5T078-7236-0	PLATE	1		

↔ Interchangeable; ≠ not Interchangeable; ← new for old; → old for new

H22700 THRESHING CYLINDER DRIVE SHAFT

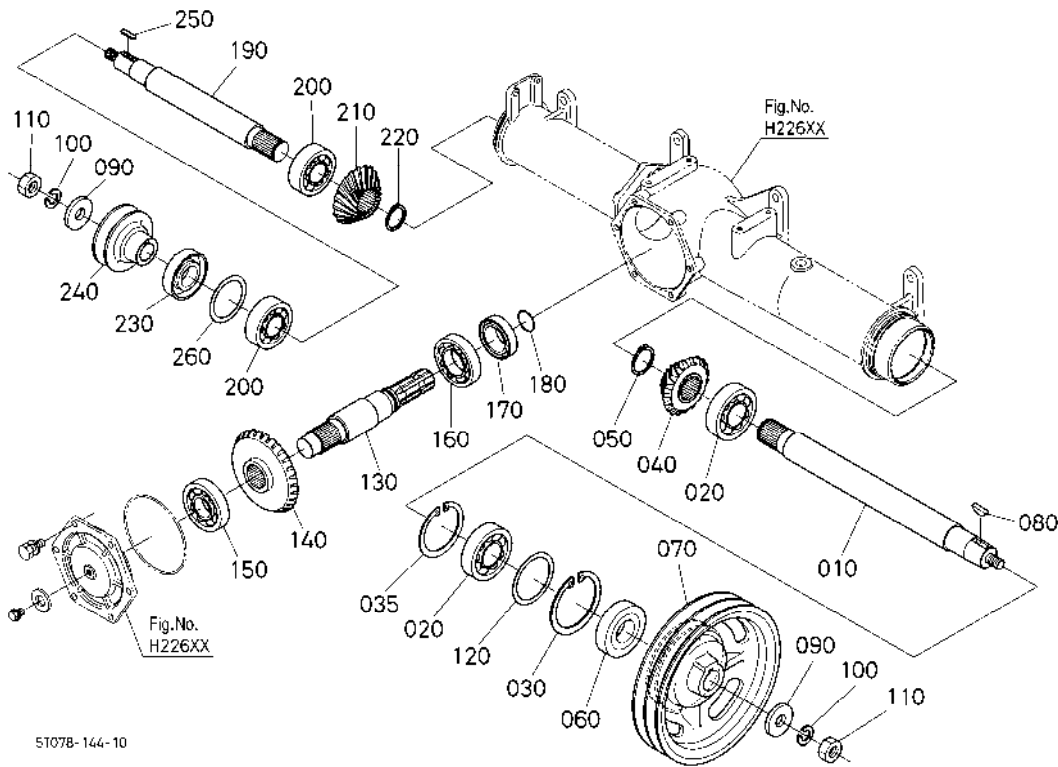

5T078-144-10

A:DC-68G HARVESKING-THRESHING

REF.No.	PART No.	PART NAME	Q'TY/S.No.	I.C.	REMARKS
			A		
010	5T072-6515-0	SHAFT	1		
020	08101-06308	BEARING,BALL	2		
030	04611-00900	CIR-CLIP,INTERNAL	1		
035	04611-00800	CIR-CLIP,INTERNAL	1		
040	5T071-6521-0	BEVEL GEAR	1	19T	
050	04612-00400	CIR-CLIP,EXTERNAL	1		
060	5T073-1071-0	SEAL,OIL	1		
070	5T078-6517-0	V PULLEY	1		
080	5T072-6518-0	KEY,WOODRUFF	1		
090	5T072-6519-0	WASHER,PLAIN	2		
100	04512-50160	WASHER,SPRING LOCK	2		
110	02174-50160	HEX.NUT	2		
120	5T072-6527-0	SHIM	1	1.0mm	
120	5T072-6528-0	SHIM	1	0.1mm	
120	5T072-6529-0	SHIM	1	0.2mm	
120	5T078-6529-0	SHIM	1	0.2mm	
120	5T051-9127-2	SHIM	1	0.1mm	
130	5T072-6536-0	SHAFT	1		
140	5T071-6522-0	GEAR,BEVEL	1	29T	
150	08101-06307	BEARING,BALL	1		
160	08101-06209	BEARING,BALL	1		
170	09500-45689	SEAL,OIL	1		
180	04816-50350	O RING	1		
190	5T072-5642-0	SHAFT	1		
200	08101-06307	BEARING,BALL	2		
210	5T071-6523-0	GEAR,BEVEL R	1	19T	
220	04612-00350	CIR-CLIP,EXTERNAL	1		
230	09503-58011	SEAL,OIL	1		
240	5T078-5643-0	PULLEY,V	1		
250	05712-00730	FEATHER KEY	1		

↔ Interchangeable; ≠ not Interchangeable; ← new for old; → old for new

H80402 ROCKING SHAFT RH

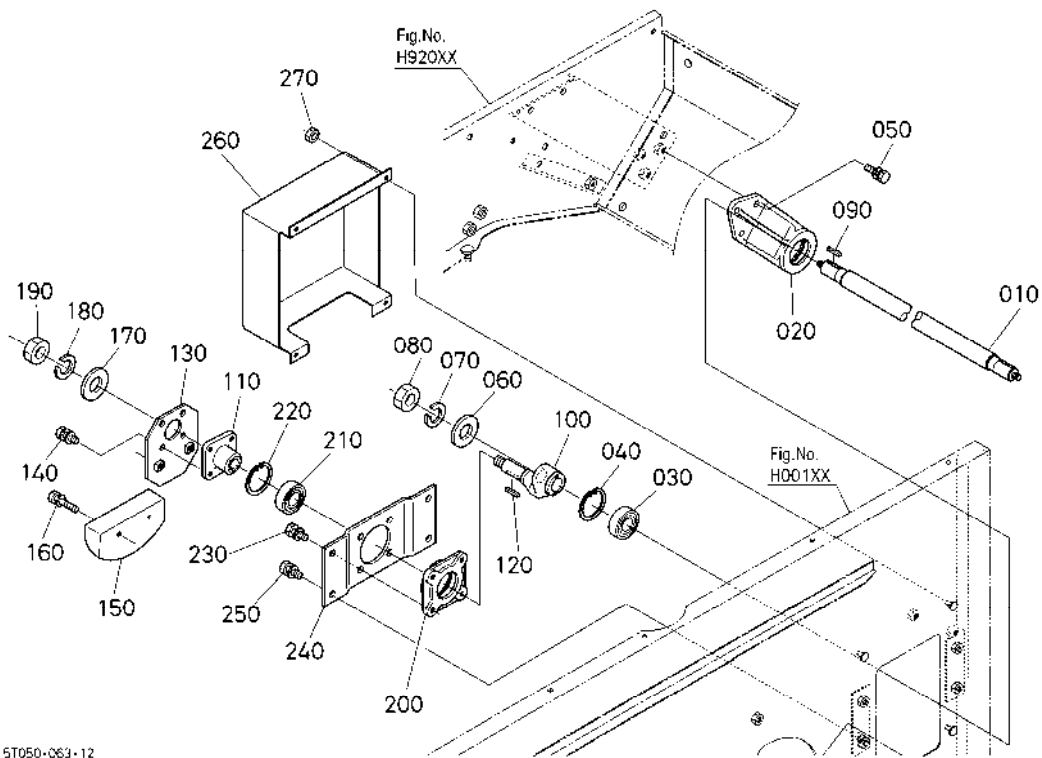

5T050-063-12

A:DC-68G HARVESKING-THRESHING

REF.No.	PART No.	PART NAME	Q'TY/S.No.	I.C.	REMARKS
			A		
010	5T072-6911-0	SHAFT(SHAKE)	1		
020	5T072-6919-0	ARM(SHAKING)	1		
030	08141-06204	BEARING,BALL	1		
040	04611-00470	CIR-CLIP,INTERNAL	1		
050	01123-50825	BOLT,SEMS	3		
060	04015-50080	WASHER,PLAIN	1		
070	04512-50080	WASHER,SPRING LOCK	1		
080	02114-50080	HEX.NUT	1		
090	05712-00525	FEATHER KEY	2		
100	5T051-6912-0	SHAFT,ROCKING	1		
110	5T072-6916-0	BOSS,ROCKING PULLEY	1		
120	05712-00525	FEATHER KEY	1		
130	5T072-6917-0	PLATE(WEIGHT)	1		
140	01125-50820	BOLT,W SEMS	4		
150	5T072-6918-0	WEIGHT(SIEVE BALANCE	1		
160	01123-50845	BOLT,SEMS	2		
170	04013-50120	WASHER,PLAIN	1		
180	04512-50120	WASHER,SPRING LOCK	1		
190	02174-50120	HEX.NUT	1		
200	5T072-6915-0	CASE,BEARING	1		
210	08141-06303	BEARING,BALL	1		
220	04611-00470	CIR-CLIP,INTERNAL	1		
230	01123-50820	BOLT,SEMS	4		
240	5T072-6941-0	PLATE(SHAKING)	1		
250	01123-50820	BOLT,SEMS	4		
260	5T078-7243-0	COVER(SHAKING,RH)	1		
270	02021-50060	NUT	4		

↔ Interchangeable; ≠ not Interchangeable; ← new for old; → old for new

H92100 SIEVE CASE CLOTH

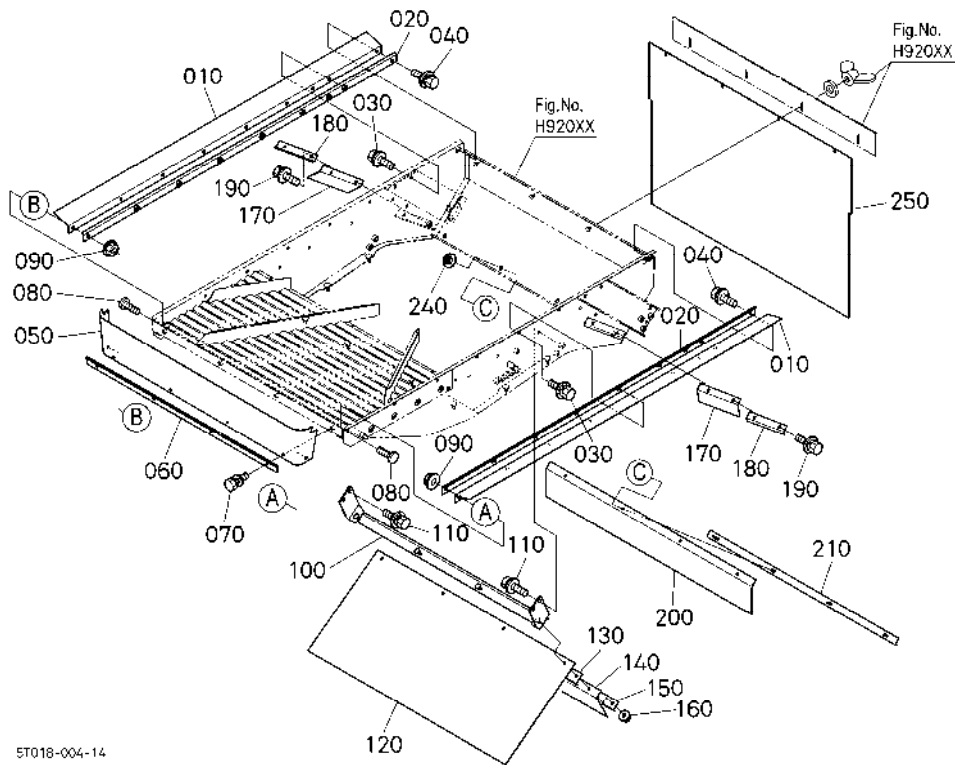

A:DC-68G HARVESKING-THRESHING

REF.No.	PART No.	PART NAME	Q'TY/S.No.	I.C.	REMARKS
			A		
010	5T078-7124-0	CLOTH,SIEVE CASE	2		
020	5T078-7125-0	PLATE,SIEVE	2		
030	01125-50820	BOLT,W SEMS	16		
040	01125-50820	BOLT,W SEMS	2		
050	5T072-7122-0	CLOTH,SIEVE CASE FR.	1		
060	5T072-7114-0	RETAINER(SIEVE,CLOTH	1		
070	01025-50616	BOLT	4		
080	01952-00825	BOLT,WELD	2		
090	02121-50080	NUT	2		
100	5T078-7126-3	PLATE(1ST)	1		
110	01125-50820	BOLT,W SEMS	4		
120	5T078-7127-0	CLOTH	1		
130	5T072-7167-0	RETAINER(SIEVE,CLOTH	1		
140	5T072-7169-0	CLOTH,FRONT	1		
150	5T072-7168-0	RETAINER(SIEVE,CLOTH	1		
160	5T072-7181-0	NUT,FLANGE	4		
170	5T078-7154-0	CLOTH,SIEVE CASE	2		
180	5T078-7155-0	PLATE,SIEVE	2		
190	01125-50820	BOLT,W SEMS	2		
200	5T078-7132-0	CLOTH,SIEVE CASE	1		
210	5T078-7115-0	RETAINER,SIEVE CLOTH	1		
220	---	BLANK	-		
230	---	BLANK	-		
240	5T072-7181-0	NUT,FLANGE	4		
250	5T078-7144-0	CLOTH(SHAFT,SHAKING)	1		

↔ Interchangeable; ≠ not Interchangeable; ← new for old; → old for new

J01000 FIRST HORIZONTAL AUGER SHAFT

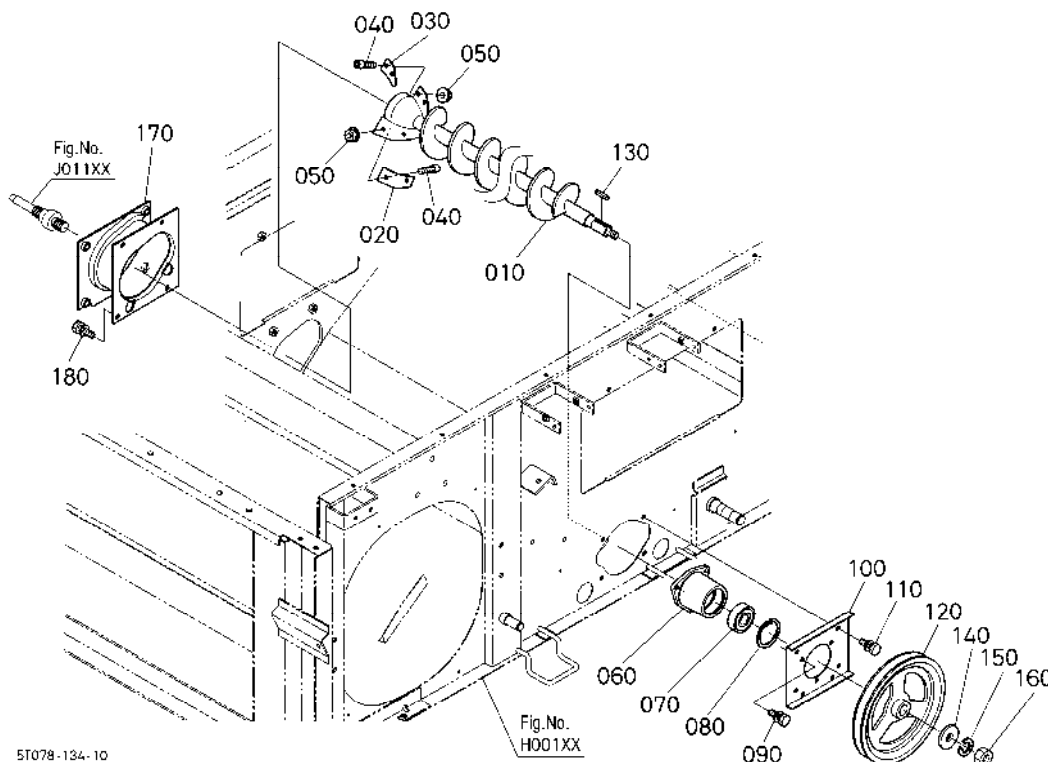

5T078-134-10

A:DC-68G HARVESKING-THRESHING

REF.No.	PART No.	PART NAME	Q'TY/S.No.	I.C.	REMARKS
			A		
010	5T078-6711-0	SHAFT,SCREW	1		
020	5T078-6713-0	TOOTH(BLADE,1)	1		
030	5T078-6714-0	TOOTH(BLADE,3)	1		
040	5T072-6728-0	SCREW,HEX SOC. CAP	4		
050	02761-50060	NUT,FLANGE	4		
060	5T072-6813-0	CASE,BEARING(SCREW)	1		
070	5H484-8634-0	BEARING	1		
080	04611-00520	CIR-CLIP,INTERNAL	1		
090	01123-50816	BOLT,SEMS	3		
100	5T078-6715-0	PLATE	1		
110	01123-50816	BOLT,SEMS	4		
120	5T072-6718-0	V PULLEY	1		
130	05712-00530	FEATHER KEY	1		
140	5T072-6722-0	WASHER(FAN)	1		
150	04512-50120	WASHER,SPRING LOCK	1		
160	02174-50120	HEX.NUT	1		
170	5T078-6721-0	HOOD	1		
180	01123-50816	BOLT,SEMS	4		

↔ Interchangeable; ≠ not interchangeable; ← new for old; → old for new

J01100 FIRST BEVEL GEAR CASE

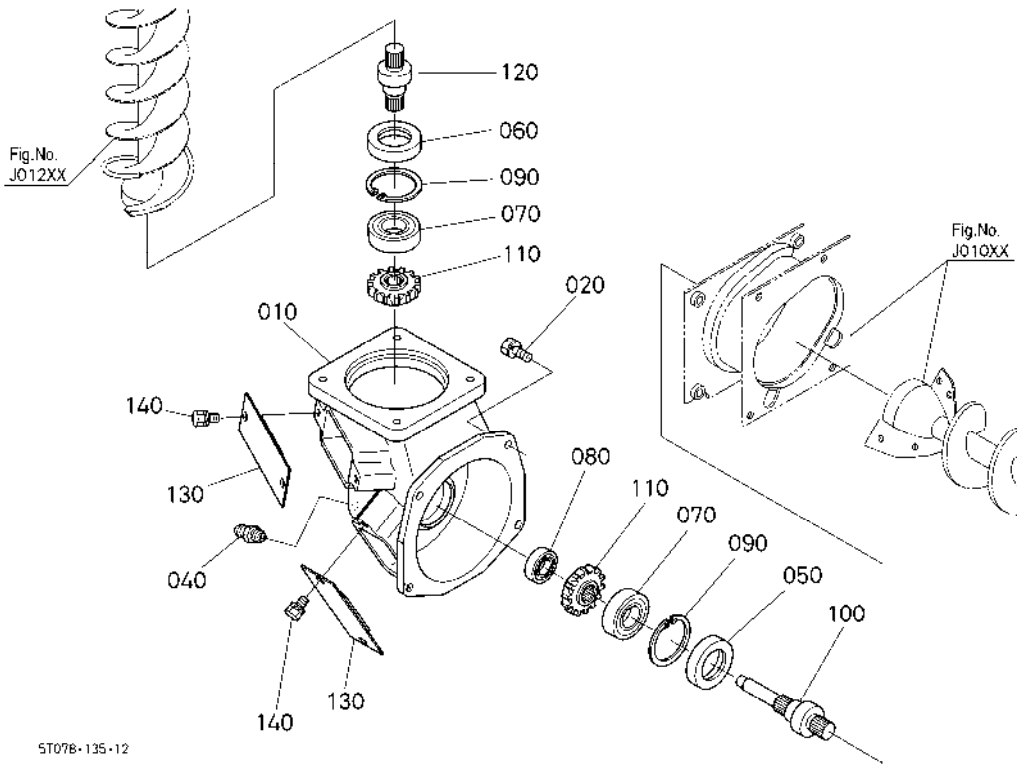

5T078-135-12

A:DC-68G HARVESKING-THRESHING

REF.No.	PART No.	PART NAME	Q'TY/S.No.	I.C.	REMARKS
			A		
010	5K190-5122-0	CASE,BEVEL GEAR	1		
020	01123-50825	BOLT,SEMS	4		
030	---	BLANK	-		
040	06613-10675	NIPPLE,GREASE	1		
050	09500-30528	SEAL,OIL	1		
060	09500-26528	SEAL,OIL	1		
070	5H484-8634-0	BEARING	2		
080	08141-06001	BALL BEARING	1		
090	04611-00520	CIR-CLIP,INTERNAL	2		
100	5T078-6723-0	SHAFT,VERTICAL BEVEL	1		
110	5T051-6724-0	GEAR	2	14T	
120	5T078-6729-0	SHAFT,VERTICAL BEVEL	1		
130	5T072-6725-0	PLATE	2		
140	01125-50816	BOLT,W SEMS	4		

↔ Interchangeable; ≠ not Interchangeable; ← new for old; → old for new

J02000 SECOND VERTICAL AUGER SHAFT

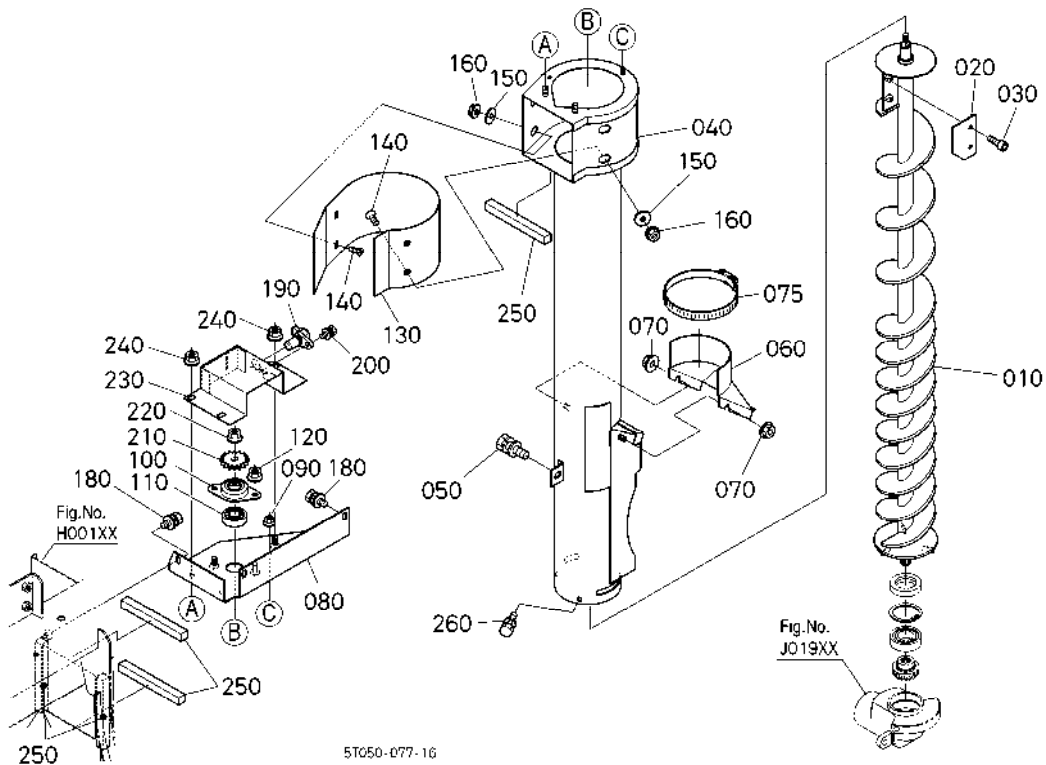

A:DC-68G HARVESKING-THRESHING

REF.No.	PART No.	PART NAME	Q'TY/S.No.	I.C.	REMARKS
			A		
010	5T078-6851-0	SHAFT,SCREW	1		
020	5T072-6862-0	BLADE	1		
030	5T072-6728-0	SCREW,HEX SOC. CAP	2		
040	5T078-6852-0	CASE,VERTICAL SCREW	1		
050	01125-50820	BOLT,W SEMS	1		
060	5T072-6858-0	COVER,VERTICAL CASE	1		
070	02121-50080	NUT	2		
075	5T072-9136-0	CLAMP,HOSE	1		
080	5T078-6853-3	PLATE(2ND,V)	1		
090	02021-50060	NUT	2		
100	5T072-6867-0	HOLDER(BEARING)	1		
110	08141-06203	BEARING,BALL	1		
120	02121-50080	NUT	2		
130	5T072-6865-0	LINER	1		
140	03016-50616	SCREW,FLAT HEAD(PHIL	4		
150	04015-50060	WASHER,PLAIN	4		
160	02021-50060	NUT	4		
170	----	BLANK	-		
180	01125-50820	BOLT,W SEMS	3		
190	T1060-3227-0	SENSOR(REVOLUTION)	1		
200	01025-50616	BOLT	1		
210	5T057-6868-0	GEAR,SENSOR	1		
220	02121-50080	NUT	1		
230	5T072-6869-0	COVER,SENSOR	1		
240	02121-50080	NUT	3		
250	5T072-6863-0	GASKET	5		
260	01123-50816	BOLT,SEMS	3		

↔ Interchangeable; ≠ not Interchangeable; ← new for old; → old for new

K00100 GRAIN TANK

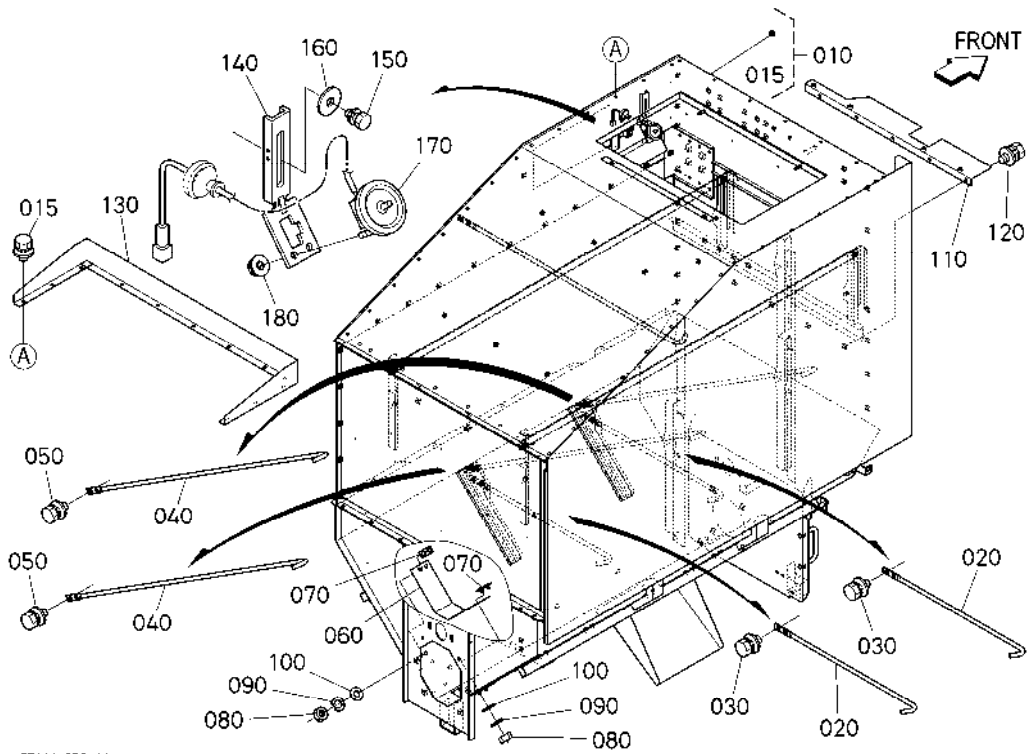

5T111-059-11

A:DC-68G HARVESKING-GRAIN TANK

REF.No.	PART No.	PART NAME	Q'TY/S.No.		I.C.	REMARKS
			A			
010	5T111-7810-0	ASSY TANK	1			
015	01125-50816	BOLT,W SEMS	89			
020	5T111-7815-2	ROD(SIDE UNDER TANK)	2			
030	01125-50816	BOLT,W SEMS	4			
040	5T111-7816-0	ROD	2			
050	01125-50816	BOLT,W SEMS	4			
060	5T072-7848-0	PLATE	1			
070	5T072-7849-0	HOLDER(LINER)	2			
080	02114-50080	HEX.NUT	4			
090	04512-50080	WASHER,SPRING LOCK	4			
100	04013-50080	WASHER,PLAIN	4			
110	5T111-7833-2	GUIDE,CANVAS	1			
120	01125-50816	BOLT,W SEMS	5			
130	5T111-7831-0	GUIDE,TANK	1			
140	5T051-7625-0	STAY,GRAIN SENSOR	1			
150	01023-50612	BOLT,SEMS	1			
160	04015-50060	WASHER,PLAIN	1			
170	5G250-1137-0	SENSOR,GRAIN	1			
180	02761-50050	NUT,FLANGE	2			

↔ Interchangeable; ≠ not Interchangeable; ← new for old; → old for new

K00300 CLEANING PORT

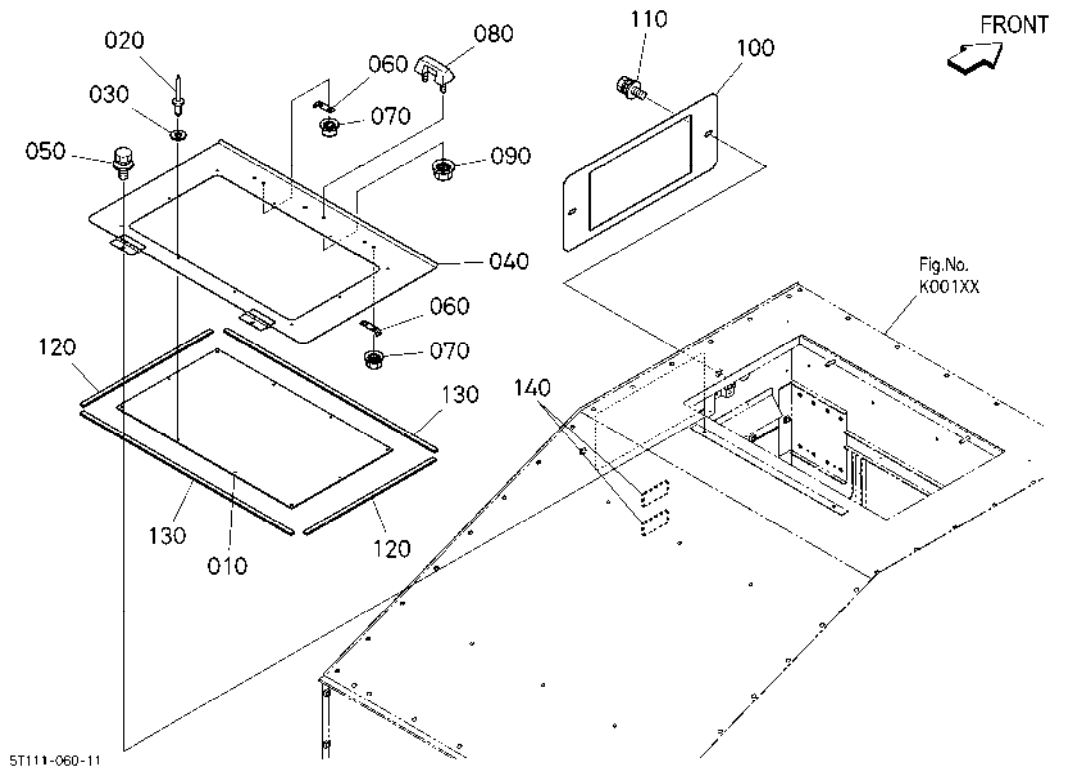

A:DC-68G HARVESKING-GRAIN TANK

REF.No.	PART No.	PART NAME	Q'TY/S.No.	I.C.	REMARKS
			A		
010	5T072-7868-0	WINDOW,TANK	1		
020	5T072-7889-2	RIVET(4X10)	10		
030	04013-50040	WASHER,PLAIN	10		
040	5T072-7869-2	COVER,TANK TOP	1		
050	01025-50616	BOLT	2		
060	5G200-1149-0	CLAMP	2		
070	02763-50080	NUT,FLANGE	4		
080	53721-5318-0	HANDLE,HOPPER COVER	1		
090	02021-50060	NUT	2		
100	5T072-7875-2	PLATE,GUIDE DELIVERY	1		
110	01125-50816	BOLT,W SEMS	2		
120	5T072-8125-0	SEAL,TANK UPPER	2		
130	5T072-8126-0	SEAL,TANK UPPER	2		
140	5T072-1214-2	RUBBER,PRESSURE-OIL	2		

↔ Interchangeable; ≠ not Interchangeable; ← new for old; → old for new

K00600 TANK LOCK

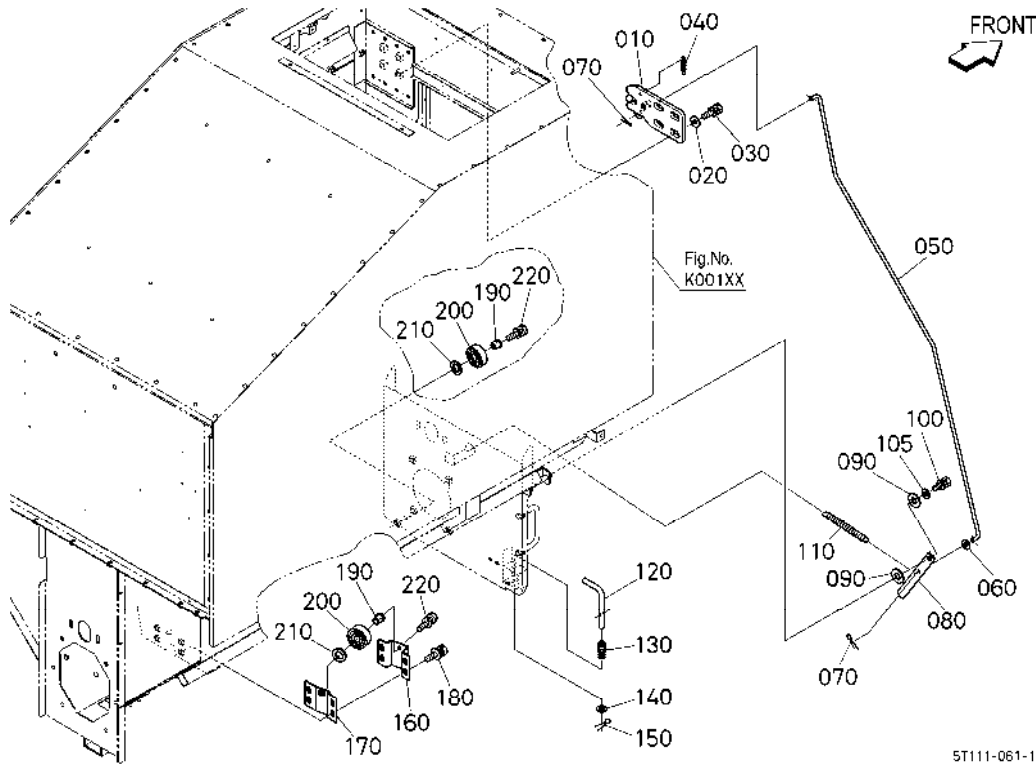

5T111-061-11

A:DC-68G HARVESKING-GRAIN TANK

REF.No.	PART No.	PART NAME	Q'TY/S.No.	I.C.	REMARKS
			A		
010	5T072-7825-2	CLAMP,TANK	1		
020	5T072-7878-0	WASHER,PLAIN	4		
030	01133-51235	BOLT,SEMS	4		
040	5T072-7879-0	SPRING	1		
050	5T078-7827-0	ROD	1		
060	04013-50080	WASHER,PLAIN	1		
070	05511-50215	PIN,SPLIT	2		
080	5T072-7828-2	LEVER,TANK OPEN	1		
090	04013-50120	WASHER,PLAIN	2		
100	01023-50616	BOLT,SEMS	1		
105	04015-50060	WASHER,PLAIN	1		
110	5T072-7822-0	SPRING	1		
120	5T072-7887-0	PIN,TANK FRONT	1		
130	5G046-1128-0	SPRING	1		
140	04013-50120	WASHER,PLAIN	1		
150	05511-50425	PIN,SPLIT	1		
160	5T072-7711-0	SUPPORT	1		
170	5T072-7712-0	SUPPORT	1		
180	01125-50820	BOLT,W SEMS	4		
190	5T072-7713-0	SHAFT	2		
200	08141-06203	BEARING,BALL	2		
210	04011-50160	WASHER,PLAIN	2		
220	01133-51040	BOLT,SEMS	2		

↔ Interchangeable; ≠ not Interchangeable; ← new for old; → old for new

K10100 TANK COVER REAR

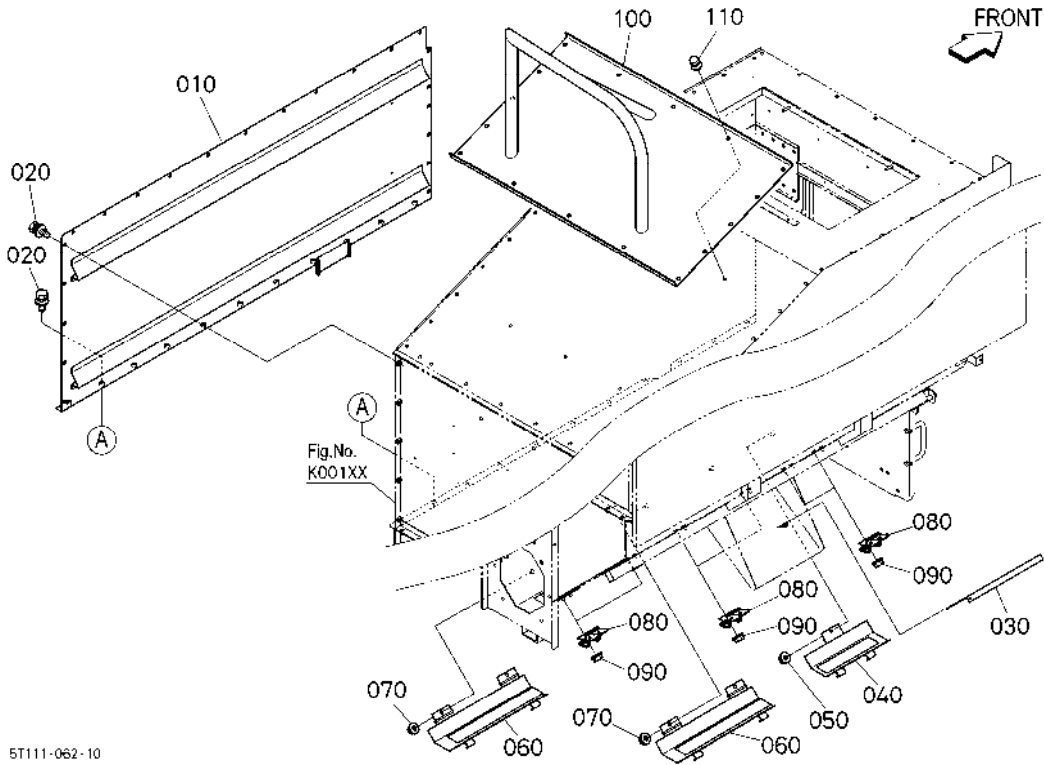

5T111-062-10

A:DC-68G HARVESKING-GRAIN TANK

REF.No.	PART No.	PART NAME	Q'TY/S.No.	I.C.	REMARKS
			A		
010	5T111-7821-0	PLATE,SIDE	1		
020	01125-50816	BOLT,W SEMS	33		
030	5T072-7872-0	SHUTTER	1		
040	5T078-7961-0	COVER	1		
050	02021-50060	NUT	1		
060	5T078-7962-0	COVER	2		
070	02021-50060	NUT	4		
080	5T078-7878-0	CLAMP(CATCH)	6		
090	02021-50060	NUT	12		
100	5T111-7822-0	GUARD(UNLOADER)	1		
110	01125-50816	BOLT,W SEMS	6		

↔ Interchangeable; ⚡ not interchangeable; ← new for old; → old for new

K10500 TANK COVER UNDER

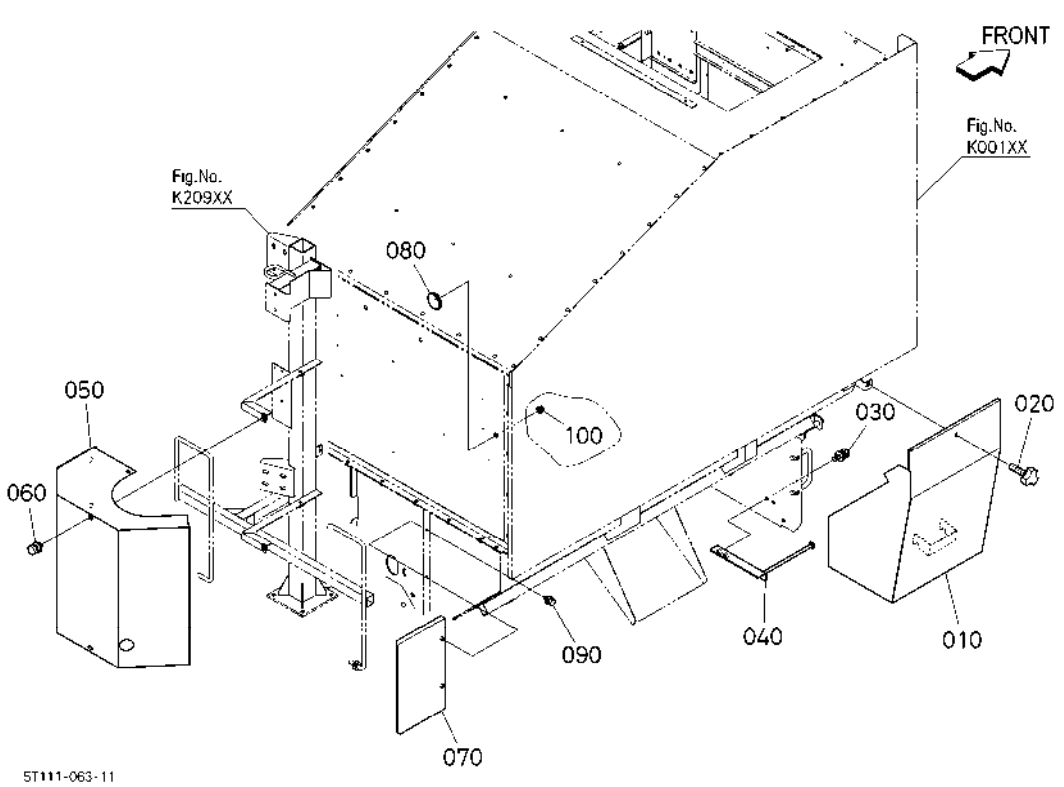

A:DC-68G HARVESKING-GRAIN TANK

REF.No.	PART No.	PART NAME	Q'TY/S.No.	I.C.	REMARKS
			A		
010	5T111-7963-0	COVER,TANK RH LOWER	1		
020	01820-50815	BOLT,KNOB	1		
030	01125-50816	BOLT,W SEMS	2		
040	5T111-7915-0	STAY,SIDE COVER	1		
050	5T111-7977-0	COVER	1		
060	01125-50816	BOLT,W SEMS	5		
070	5T111-7978-0	COVER	1		
080	5T072-7214-0	REFLECTOR	1		
090	01025-50616	BOLT	2		
100	02021-50050	NUT	1		

↔ Interchangeable; ≠ not interchangeable; ← new for old; → old for new

K18000 TANK DRIVE CASE

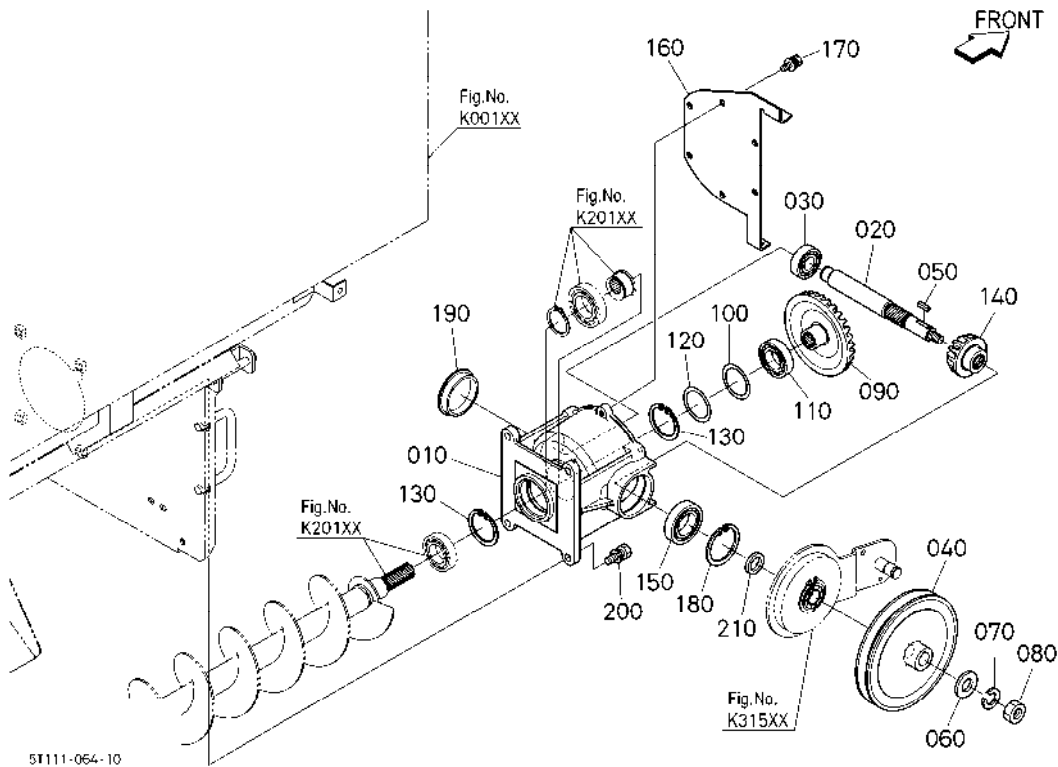

5T111-064-10

A:DC-68G HARVESKING-GRAIN TANK

REF.No.	PART No.	PART NAME	Q'TY/S.No.	I.C.	REMARKS
			A		
010	5T072-7831-0	CASE,GEAR	1		
020	5T072-7832-0	SHAFT	1		
030	08141-06204	BEARING,BALL	1		
040	5T072-7996-0	PULLEY,V	1		
050	05712-00525	FEATHER KEY	1		
060	04015-50120	WASHER,PLAIN	1		
070	04512-50120	WASHER,SPRING LOCK	1		
080	02174-50120	HEX,NUT	1		
090	5T055-7833-0	GEAR,BEVEL	1		31T
100	5T072-7966-0	SHIM	1		0.2mm
110	08141-06006	BEARING,BALL	1		
120	5T072-7967-0	SHIM	1		0.3mm
130	04611-00550	SAFETY RING IN ASSY	2		
140	5T055-7834-0	GEAR,BEVEL	1		14T
150	08141-06007	BEARING,BALL	1		
160	5T072-7845-0	PLATE,GEAR CASE	1		
170	01125-50816	BOLT,W SEMS	6		
180	04611-00620	CIR-CLIP,INTERNAL	1		
190	50727-4361-2	PLUG	1		
200	01133-51030	BOLT,SEMS	4		
210	5T072-7836-0	COLLAR	1		

↔ Interchangeable; ≠ not interchangeable; ← new for old; → old for new

K20000 UNLOADER CASE 1

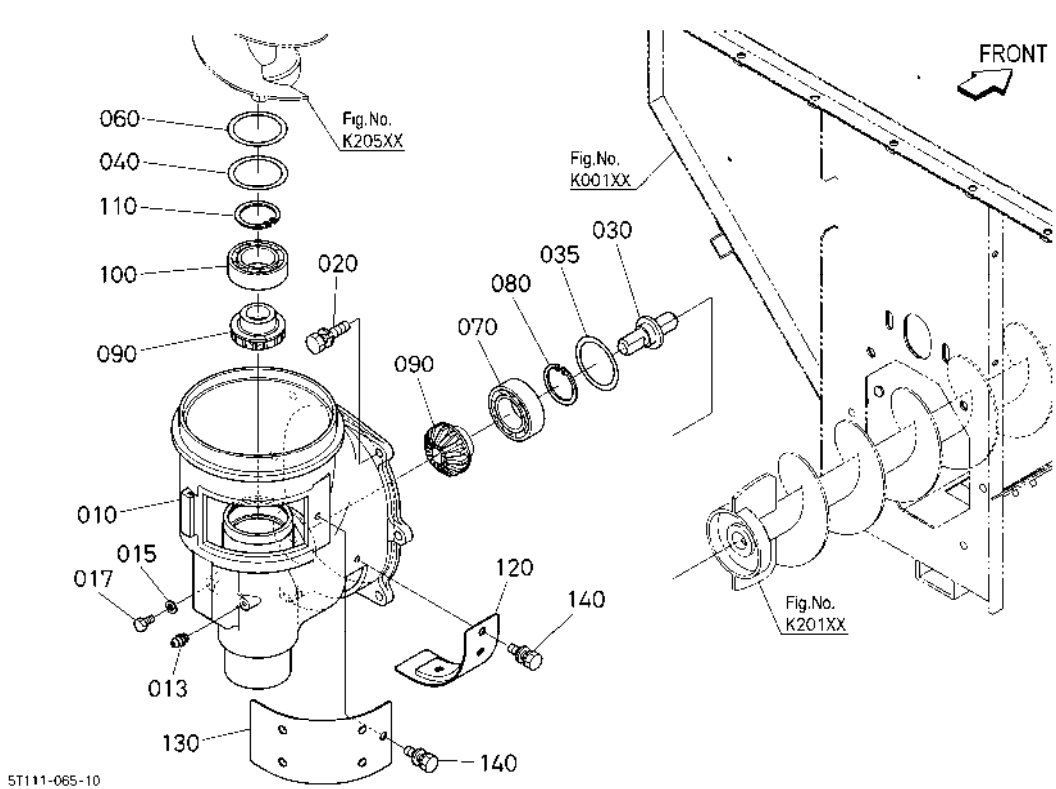

A:DC-68G HARVESKING-GRAIN TANK

REF.No.	PART No.	PART NAME	Q'TY/S.No.	I.C.	REMARKS
			A		
010	5T072-7851-5	CASE,1 UNLOADER	1		
013	06613-10675	NIPPLE,GREASE	1		
015	04711-00060	PACKING	1		
017	01053-50610	HEX.BOLT	1		
020	01133-51030	BOLT,SEMS	6		
030	5T072-7843-0	SHAFT	1		
035	5T072-7965-0	SHIM	1	0.5mm	
040	5T072-7968-0	SHIM	1	0.2mm	
050	---	BLANK	-		
060	5T072-7969-0	SHIM	1	0.3mm	
070	08141-06008	BEARING,BALL	1		
080	04611-00680	CIR-CLIP,INTERNAL	1		
090	5G230-2265-0	GEAR,BEVEL	2	15T	
100	08141-06008	BEARING,BALL	1		
110	04611-00680	CIR-CLIP,INTERNAL	1		
120	5T072-7855-0	COVER,CLEANING HOLE	1		
130	5T072-7857-0	COVER,CLEANING HOLE	1		
140	01125-50816	BOLT,W SEMS	2		

↔ Interchangeable; ≠ not interchangeable; ← new for old; → old for new

K20200 EXHAUST SHUTTER

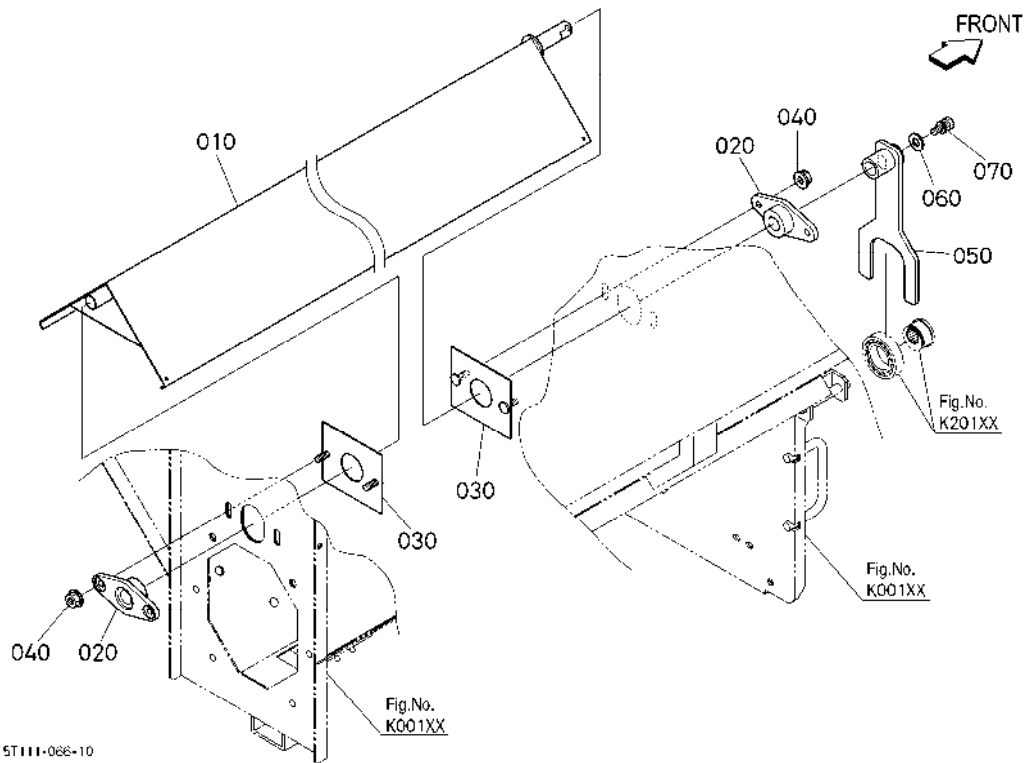

A:DC-68G HARVESKING-GRAIN TANK

REF.No.	PART No.	PART NAME	Q'TY/S.No.	I.C.	REMARKS
			A		
010	5T078-7824-0	GRIP,SHUTTER	1		
020	5T055-7829-0	HOLDER,SHUTTER	2		
030	5T072-7847-0	PLATE,SHUTTER	2		
040	02121-50080	NUT	4		
050	5T072-7846-0	ARM,SHUTTER	1		
060	04015-50080	WASHER,PLAIN	1		
070	01123-50816	BOLT,SEMS	1		

↔ Interchangeable; ≠ not Interchangeable; ← new for old; → old for new

K20900 MOUNTING FRAME

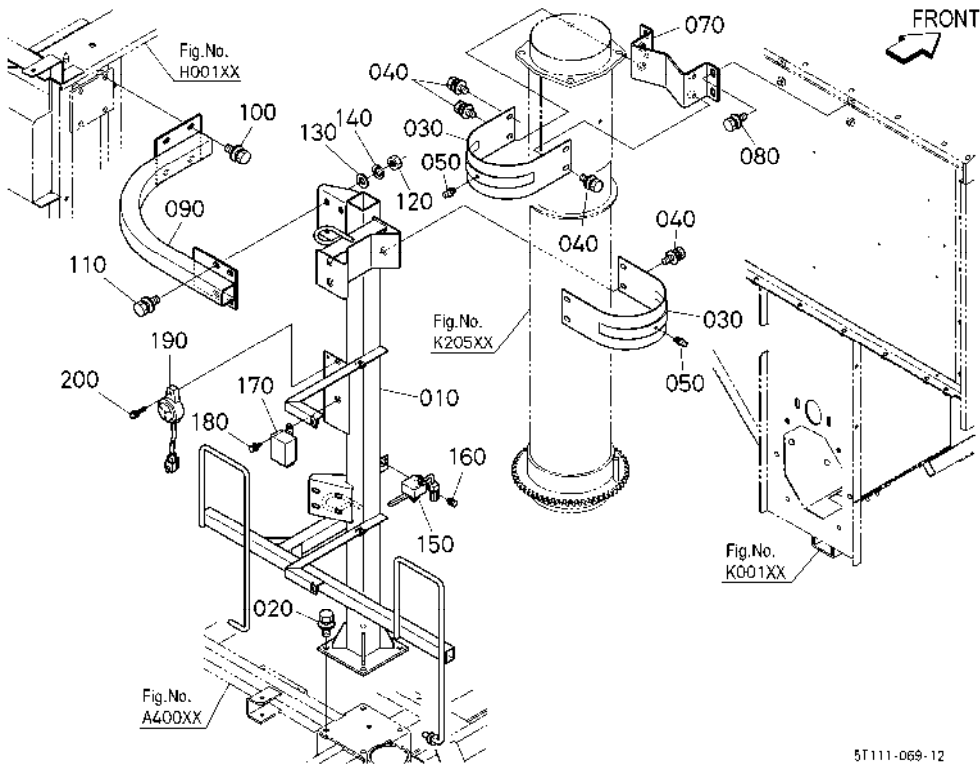

5T111-069-12

A:DC-68G HARVESKING-GRAIN TANK

REF.No.	PART No.	PART NAME	Q'TY/S.No.	I.C.	REMARKS
			A		
010	5T111-7911-0	FRAME REAR, TANK	1		
020	01135-51025	BOLT, W SEMS	4		
030	5T072-7913-0	HOLDER, UNLOADER PIPE	2		
040	01127-50820	BOLT, W SEMS(LARGE WA	8		
050	06613-10675	NIPPLE, GREASE	2		
060	----	BLANK	-		
070	5T072-7914-2	HOLDER, PIPE	1		
080	01135-51020	BOLT, W SEMS	4		
090	5T078-7916-4	BEAM, THRESH CONNECT	1		
100	01135-51025	BOLT, W SEMS	4		
110	01135-51025	BOLT, W SEMS	4		
120	02118-50100	HEX. NUT	4		
130	04013-50100	WASHER, PLAIN	4		
140	04512-50100	WASHER, SPRING LOCK	4		
150	5G127-7126-0	SWITCH	1		
160	01025-50616	BOLT	1		
170	5T055-8193-2	COMP, RELAY	1		
180	01025-50620	BOLT	1		
190	5T057-4228-0	BUZZER, BACK	1		
200	03034-50525	SCREW, W SEMS(PAN HEA	1		

↔ Interchangeable; ≠ not Interchangeable; ← new for old; → old for new

K23000 UNLOADER CASE 2

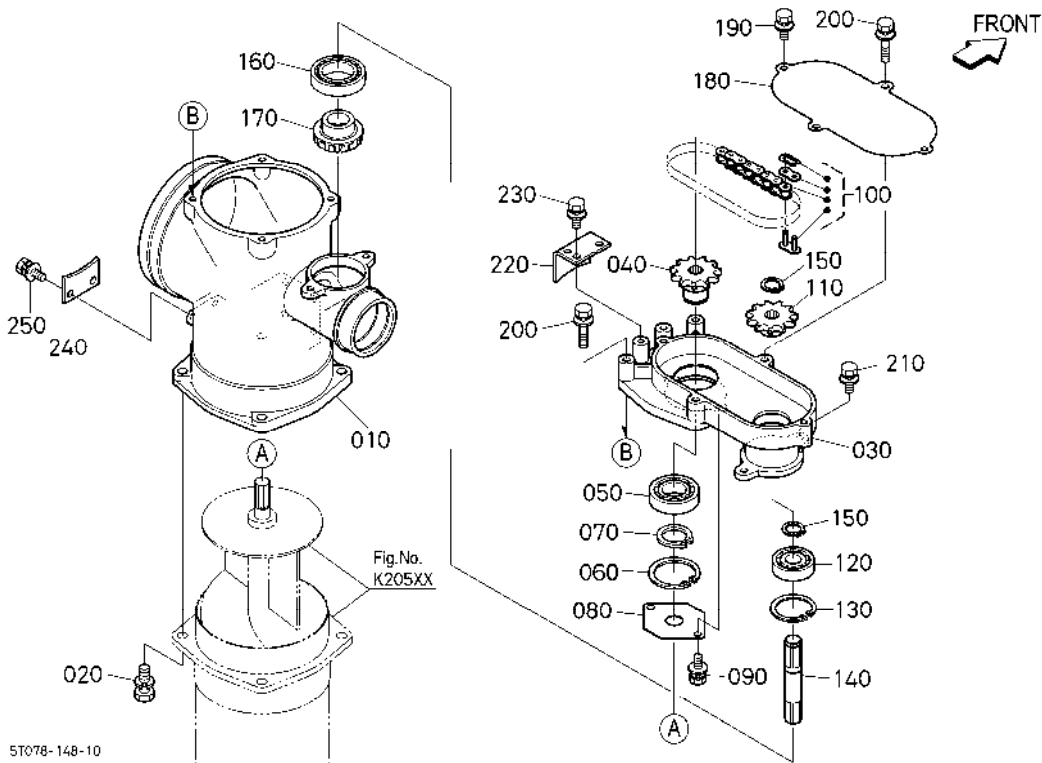

A:DC-68G HARVESKING-GRAIN TANK

REF.No.	PART No.	PART NAME	Q'TY/S.No.	I.C.	REMARKS
			A		
010	5T072-7921-2	CASE,UNLOADER 2	1		
020	01123-51230	BOLT,SEMS	4		
030	5T072-8171-0	CASE,CHAIN	1		
040	5T055-8172-2	SPROCKET,11T,1	1		
050	08141-06206	BEARING,BALL	1		
060	04611-00620	CIR-CLIP,INTERNAL	1		
070	04612-00300	CIR-CLIP,EXTERNAL	1		
080	5T072-7923-0	COVER	1		
090	01125-50816	BOLT,W SEMS	2		
100	5T070-8173-0	CHAIN,LINK	1		
110	5T055-8174-2	SPROCKET	1		
120	08141-06304	BEARING,BALL	1		
130	04611-00520	CIR-CLIP,INTERNAL	1		
140	5T055-8177-0	SHAFT	1		
150	04612-00200	CIR-CLIP,EXTERNAL	2		
160	08141-06008	BEARING,BALL	1		
170	5T070-7924-0	GEAR,BEVEL	1		
180	5T072-8176-0	COVER	1		
190	01125-50816	BOLT,W SEMS	2		
200	01125-50855	BOLT,W SEMS	4		
210	01125-50820	BOLT,W SEMS	2		
220	5T072-7925-0	PLATE,STOPPER	1		
230	01125-50816	BOLT,W SEMS	2		
240	5T072-7933-0	PLATE,STOPPER	1		
250	01125-50816	BOLT,W SEMS	2		

↔ Interchangeable; ≠ not Interchangeable; ← new for old; → old for new

K23400 TRANSMISSION SHAFT

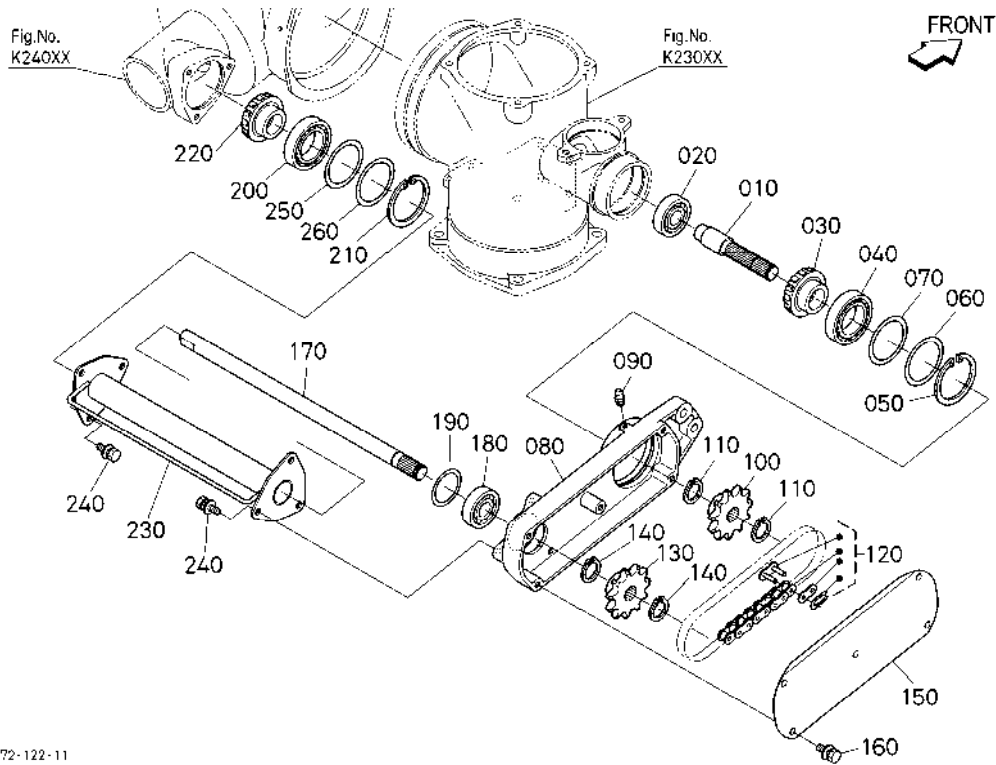

5T072-122-11

A:DC-68G HARVESKING-GRAIN TANK

REF.No.	PART No.	PART NAME	Q'TY/S.No.	I.C.	REMARKS
			A		
010	5T055-8175-0	SHAFT	1		
020	08141-06304	BEARING,BALL	1		
030	5T070-7924-0	GEAR,BEVEL	1	25T	
040	08141-06008	BEARING,BALL	1		
050	04611-00680	CIR-CLIP,INTERNAL	1		
060	5T072-7968-0	SHIM	1	0.2mm	
070	5T072-7969-0	SHIM	1	0.3mm	
080	5T072-8178-2	CASE,CHAIN 2	1		
090	06613-10675	NIPPLE,GREASE	1		
100	5T055-8174-2	SPROCKET	1		
110	04612-00200	CIR-CLIP,EXTERNAL	2		
120	5T055-8179-0	CHAIN,LINK	1		
130	5T055-8174-2	SPROCKET	1		
140	04612-00200	CIR-CLIP,EXTERNAL	2		
150	5T072-8181-2	COVER,CHAIN-CASE 2	1		
160	01125-50820	BOLT,W SEMS	5		
170	5T055-8182-2	SHAFT,DRIVE,3	1		
180	08141-06304	BEARING,BALL	1		
190	5T072-8186-0	SHIM	1		
200	08141-06008	BEARING,BALL	1		
210	04611-00680	CIR-CLIP,INTERNAL	1		
220	5G230-2265-0	GEAR,BEVEL	1	15T	
230	5T071-8183-3	PIPE,DRIVE,3	1		
240	01125-50820	BOLT,W SEMS	6		
250	5T072-7968-0	SHIM	1	0.2mm	
260	5T072-7969-0	SHIM	1	0.3mm	

↔ Interchangeable; ≠ not interchangeable; ← new for old; → old for new

K24000 UNLOADER CASE 3

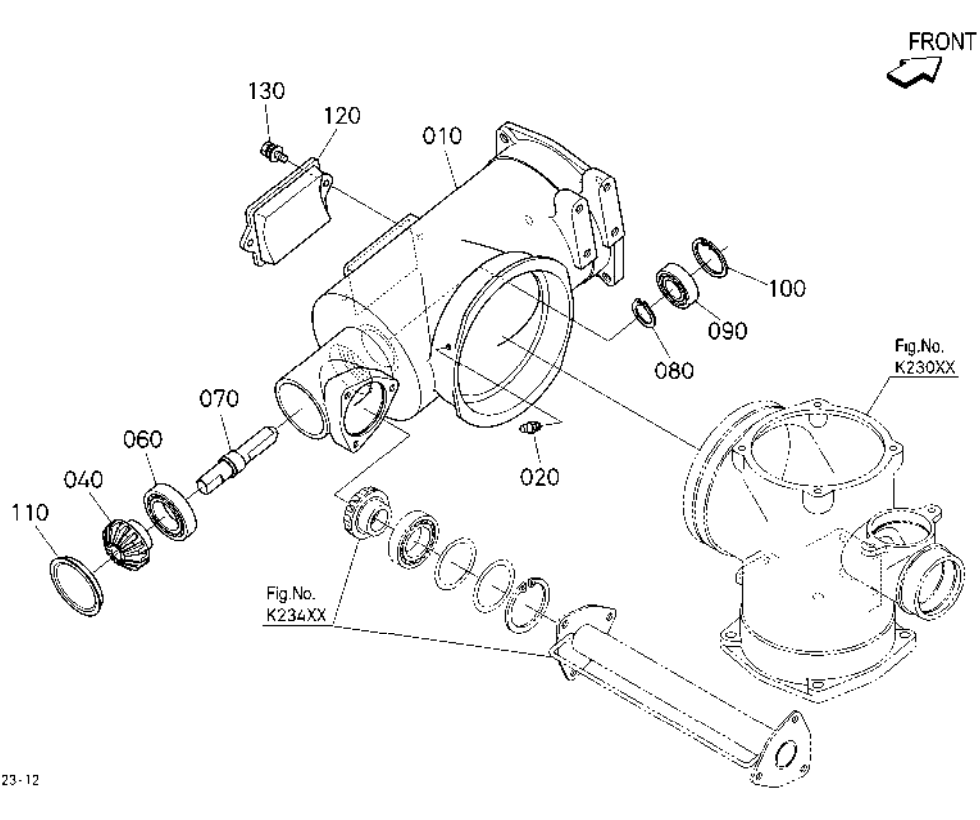

5T072-123-12

A:DC-68G HARVESKING-GRAIN TANK

REF.No.	PART No.	PART NAME	Q'TY/S.No.	I.C.	REMARKS
			A		
010	5T072-7931-2	CASE, UNLOADER 3	1		
020	06613-10675	NIPPLE, GREASE	1		
030	---	BLANK	-		
040	5G230-2265-0	GEAR, BEVEL	1	15T	
050	---	BLANK	-		
060	08141-06008	BEARING, BALL	1		
070	5T055-8184-0	SHAFT	1		
080	04612-00250	CIR-CLIP, EXTERNAL	1		
090	08141-06205	BEARING, BALL	1		
100	04611-00520	CIR-CLIP, INTERNAL	1		
110	7C765-5126-0	CAP	1		
120	5T072-7861-2	COVER, CLEANING HOLE	1		
130	01125-50816	BOLT, W SEMS	2		

↔ Interchangeable; ≠ not Interchangeable; ← new for old; → old for new

K30000 UNLOADER

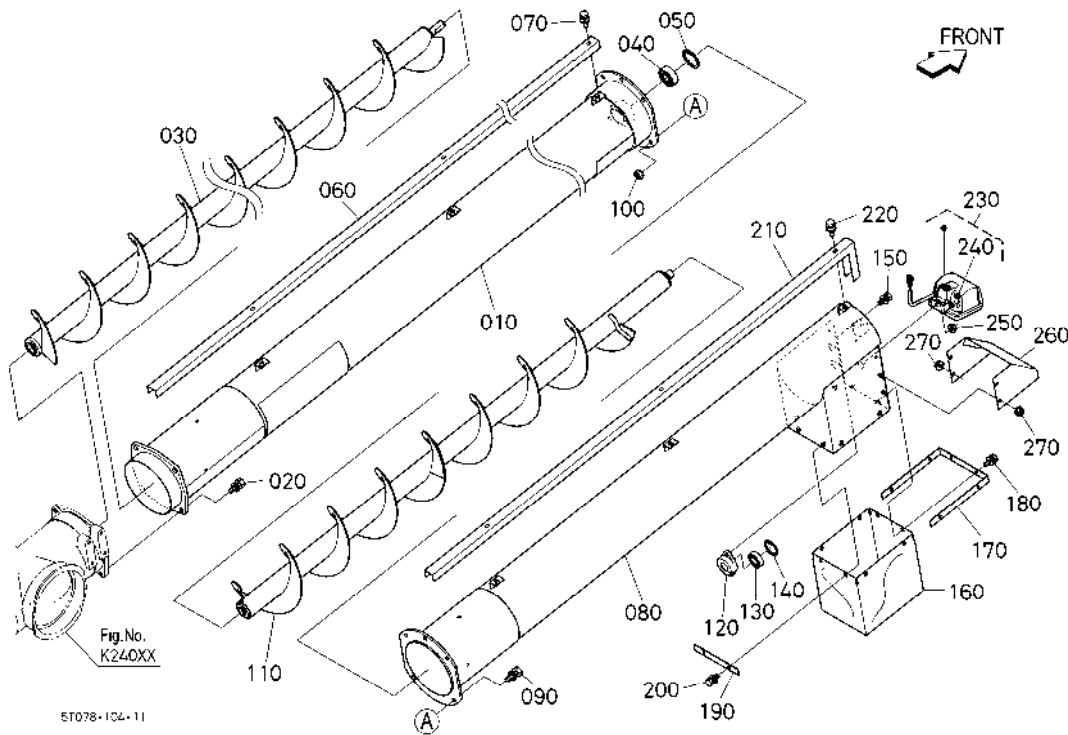

5T078-104-11

A:DC-68G HARVESKING-GRAIN TANK

REF.No.	PART No.	PART NAME	Q'TY/S.No.	I.C.	REMARKS
			A		
010	5T072-7934-0	PIPE,UNROADER	1		
020	01123-51230	BOLT,SEMS	4		
030	5T072-7932-0	SHAFT,SCREW	1		
040	08141-06004	BEARING,BALL	1		
050	04611-00420	CIR-CLIP,INTERNAL	1		
060	5T072-7939-0	COVER	1		
070	01025-50612	BOLT	3		
080	5T078-7943-0	PIPE,UNROADER	1		
090	01133-51030	BOLT,SEMS	5		
100	02118-50100	HEX.NUT	5		
110	5T078-7941-0	SHAFT,SCREW	1		
120	5T072-7945-0	HOLDER,BEARING	1		
130	08141-06004	BEARING,BALL	1		
140	04611-00420	CIR-CLIP,INTERNAL	1		
150	01125-50816	BOLT,W SEMS	2		
160	5T078-7946-0	BOOT,UNLOADER	1		
170	5T072-7947-0	CLAMP,BOOT	1		
180	01025-50616	BOLT	6		
190	5T072-7948-0	CLAMP,BOOT	1		
200	01025-50616	BOLT	2		
210	5T078-7949-0	COVER	1		
220	01025-50612	BOLT	3		
230	5T071-3138-2	ASSY LIGHT,WORKING	1		
240	5H484-3139-2	BULB	1	55W	
250	02751-50080	NUT,FLANGE	1		
260	5T072-7954-2	COVER,UNROADER LIGHT	1		
270	02751-50080	NUT,FLANGE	4		

↔ Interchangeable; ≠ not Interchangeable; ← new for old; → old for new

K30300 UNLOADER STAY

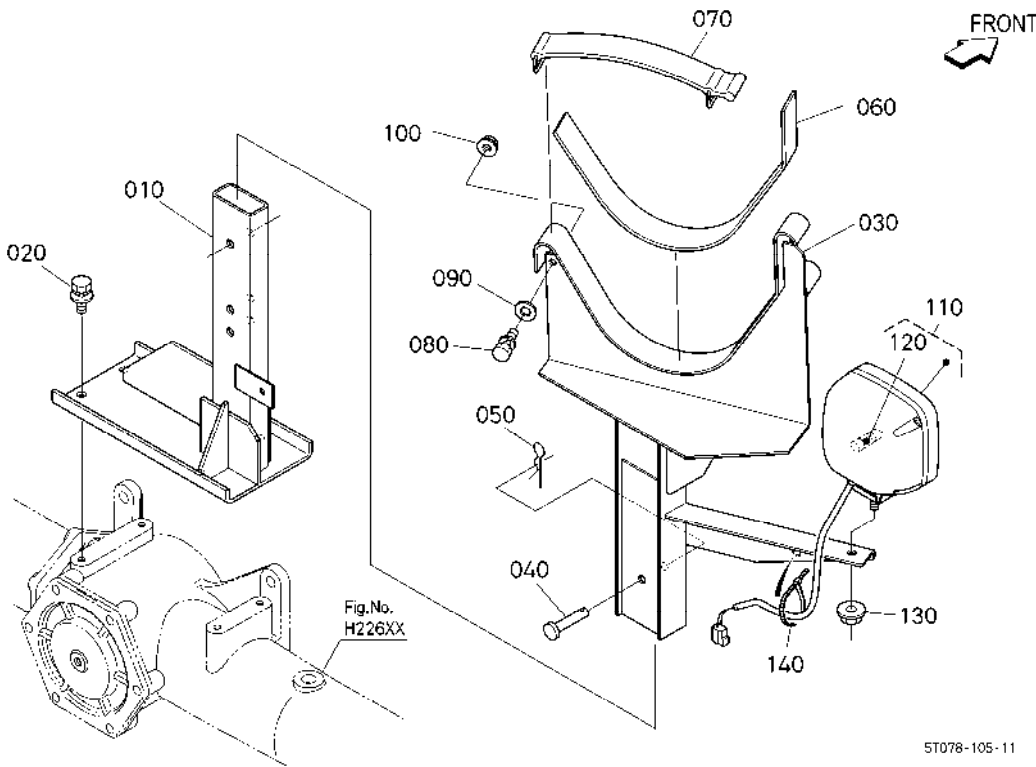

A:DC-68G HARVESKING-GRAIN TANK

REF.No.	PART No.	PART NAME	Q'TY/S.No.	I.C.	REMARKS
			A		
010	5T078-7971-0	STAY	1		
020	01125-50820	BOLT,W SEMS	4		
030	5T078-7972-0	STAY,PIPE	1		
040	05122-50845	PIN JOINT	1		
050	05515-50800	PIN,SNAP	1		
060	5T072-7974-0	CUSHION	1		
070	5T072-7975-0	BAND	1		
080	01023-50616	BOLT,SEMS	1		
090	04015-50060	WASHER,PLAIN	2		
100	02761-50060	NUT,FLANGE	1		
110	5H484-3138-2	ASSY LAMP,ELECTRIC	1		
120	5H484-3139-2	BULB	1	55W	
130	02121-50080	NUT	1		
140	TC402-6838-0	BAND,CORD	1		

↔ Interchangeable; ≠ not interchangeable; ← new for old; → old for new

K31500 TANK DRIVE

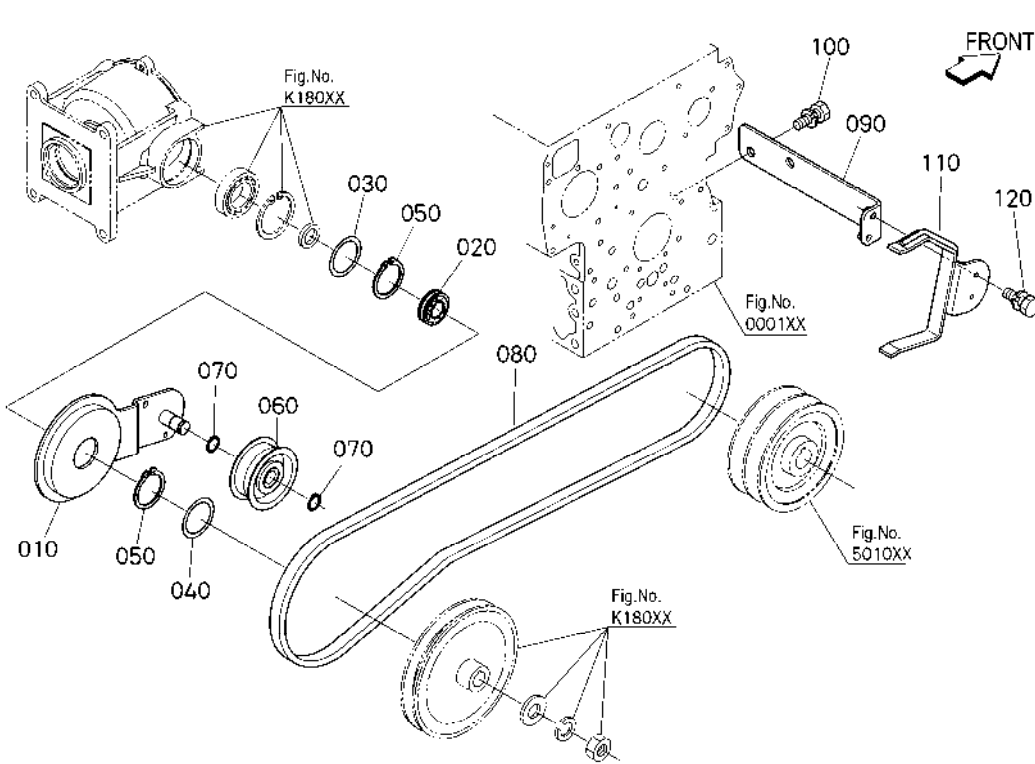

5T078-106-10

A:DC-68G HARVESKING-GRAIN TANK

REF.No.	PART No.	PART NAME	Q'TY/S.No.	I.C.	REMARKS
			A		
010	5T072-8113-0	ARM,TENSION	1		
020	5G072-1119-0	BEARING	1		
030	5T072-7966-0	SHIM	1	0.2mm	
040	5T072-7967-0	SHIM	1	0.3mm	
050	04612-00420	CIR-CLIP,EXTERNAL	2		
060	5G200-2232-0	PULLEY,TENSION	1		
070	04612-00170	CIR-CLIP,EXTERNAL	2		
080	5T072-8117-0	BELT,V	1		
090	5T078-8121-0	RETAINER,CLUTCH	1		
100	01133-51225	BOLT,SEMS	2		
110	5T078-8123-0	RETAINER,CLUTCH	1		
120	01125-50820	BOLT,W SEMS	2		

↔ Interchangeable; ≠ not Interchangeable; ← new for old; → old for new

K31700 TANK CLUTCH

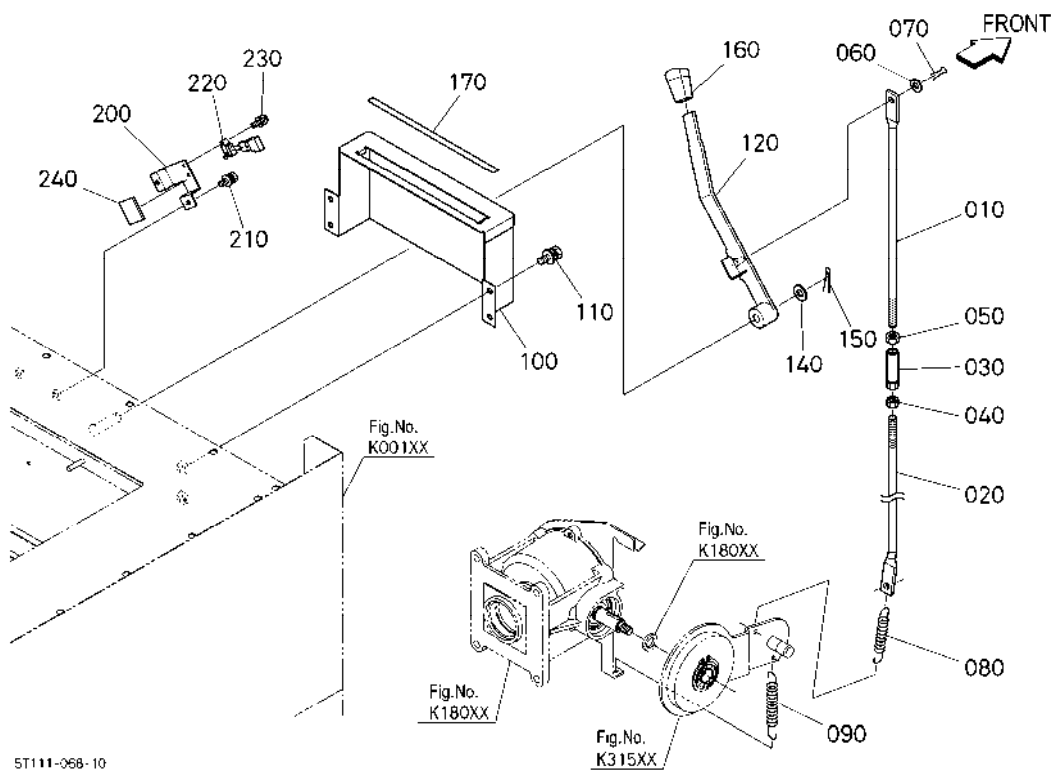

A:DC-68G HARVESKING-GRAIN TANK

REF.No.	PART No.	PART NAME	Q'TY/S.No.	I.C.	REMARKS
			A		
010	5T111-8138-0	ROD	1		
020	5T111-8139-0	ROD	1		
030	5T072-8141-2	TURNBuckle(M10-70)	1		
040	TC403-2899-0	NUT	1		
050	02118-50100	HEX.NUT	1		
060	04013-50080	WASHER,PLAIN	1		
070	05511-50215	PIN,SPLIT	1		
080	5T072-8116-0	SPRING,TENSION	1		
090	5T072-8118-2	SPRING,TENS.(RETURN)	1		
100	5T072-8134-0	GUIDE	1		
110	01125-50816	BOLT,W SEMS	4		
120	5T072-8136-2	LEVER,TANK CLUTCH	1		
130	----	BLANK	-		
140	04011-50120	WASHER,PLAIN	1		
150	05511-50430	PIN,SPLIT	1		
160	5T072-3128-0	GRIP	1		
170	5T072-4386-0	LABEL	1		
180	----	BLANK	-		
190	----	BLANK	-		
200	5T072-8135-0	PLATE,SWITCH	1		
210	01025-50616	BOLT	2		
220	PL501-6885-0	SWITCH	1		
230	03024-50416	SCREW,SEMS(PAN HEAD)	1		
240	5T111-8136-0	RUBBER	1		

↔ Interchangeable; ≠ not Interchangeable; ← new for old; → old for new

N10000 LABEL (ENGINE)

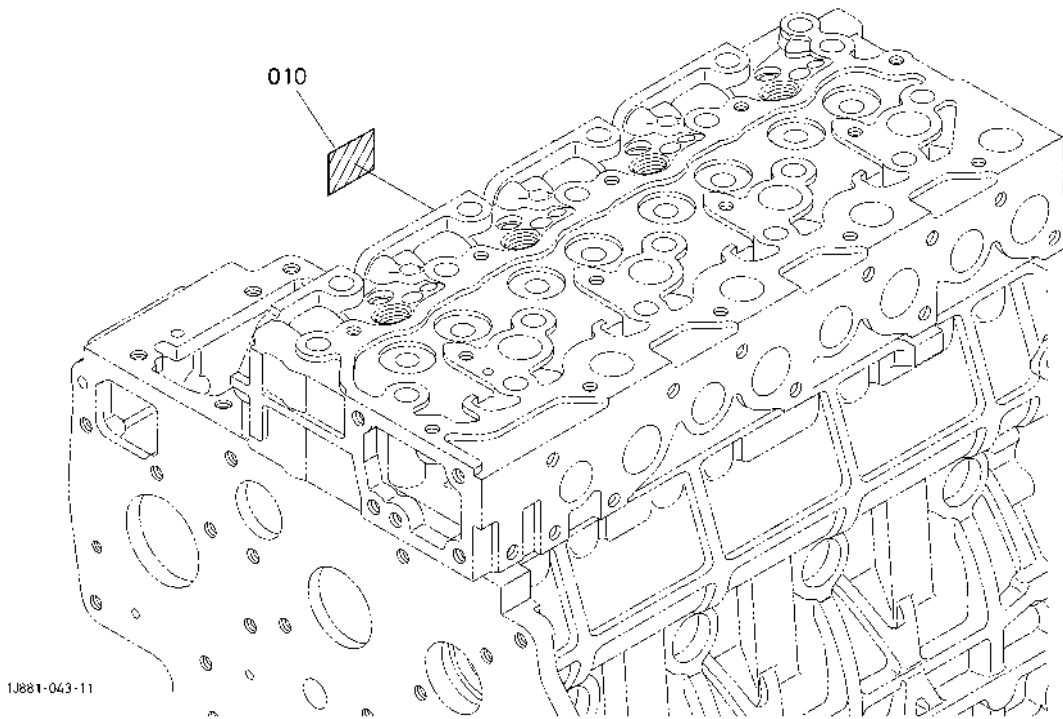

1J881-043-11

A:V2403-M-DI-TE-CS3T

REF.No.	PART No.	PART NAME	Q'TY/S.No.	I.C.	REMARKS
			A 1		
010	1J873-8721-0	LABEL,PUMP	1		

↔ Interchangeable; ≠ not Interchangeable; ← new for old; → old for new

N10500 LABEL(BODY)

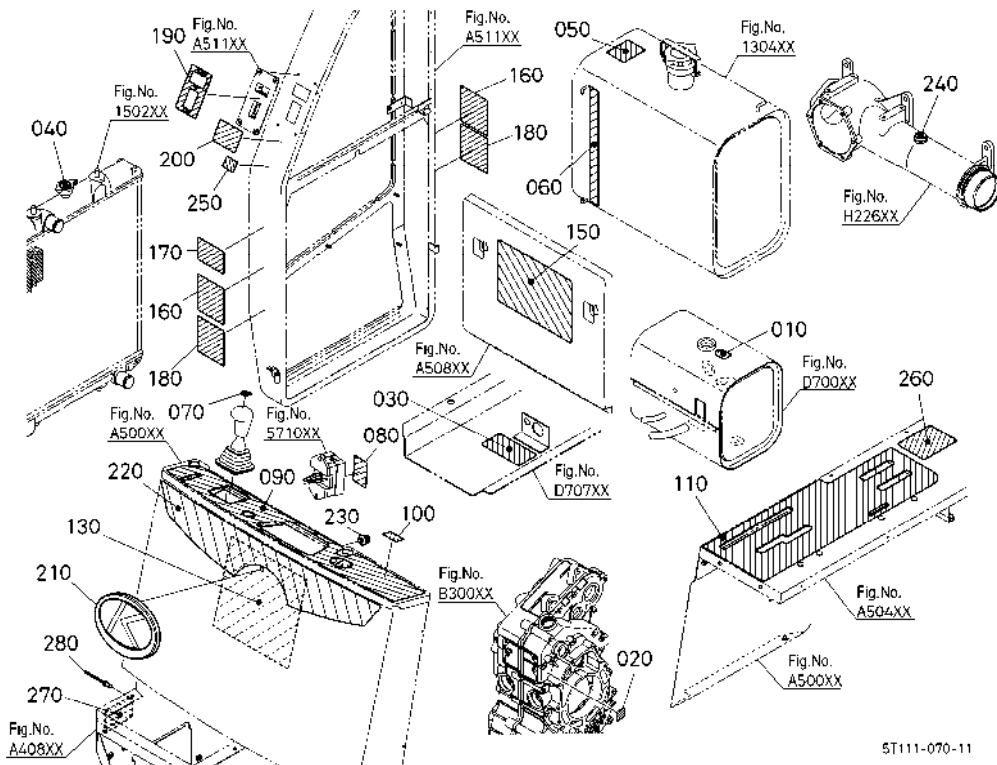

5T111-070-11

A:DC-68G HARVESKING

REF.No.	PART No.	PART NAME	Q'TY/S.No.	I.C.	REMARKS
			A		
010	5T111-4394-0	LABEL(UDT)	1		
020	5T111-4395-2	LABEL(UDT OIL,TM)	1		
030	5T111-4393-0	LABEL	1		
040	5T019-4322-0	LABEL,CAUTION	1		
050	5T019-4326-0	LABEL	1		
060	5T051-4327-0	LABEL,FUEL GAUGE	1		
070	5T051-3117-0	LABEL	1		
080	5T078-4333-2	LABEL,FUSE	1		
090	5T078-4337-2	LABEL,STARTER	1		
100	5T019-4338-0	LABEL,CAUTION	1		
110	5T111-4334-2	LABEL,CHANGE CLUTCH	1		
120	---	BLANK	-		
130	5T111-4342-0	LABEL,CAUTION	1		
140	---	BLANK	-		
150	5T111-4421-0	LABEL(GREASE)	1		
160	5T019-4343-0	LABEL,CAUTION	2		
170	5T019-4344-0	LABEL,CAUTION	1		
180	5T019-4348-0	LABEL,CAUTION	2		
190	5T072-4385-0	LABEL,UNLOADER	1		
200	5T019-4387-0	LABEL,CAUTION	1		
210	5T072-4371-0	MARK, K EMBLEM	1		
220	5T051-4371-2	MARK,FRONT	1		
230	03034-50406	SCREW,W SEMS(PAN HEA	3		
240	5T111-4396-2	LABEL(GEAR OIL 2.3)	1		
250	5T019-4395-0	LABEL,CAUTION	1		
260	5T019-4426-0	LABEL,AIR CLEANER	1		
270	---	NAME PLATE	1		
280	5T072-7889-2	RIVET(4X10)	4		

↔ Interchangeable; ≠ not Interchangeable; ← new for old; → old for new

N11000 LABEL(HARVEST)

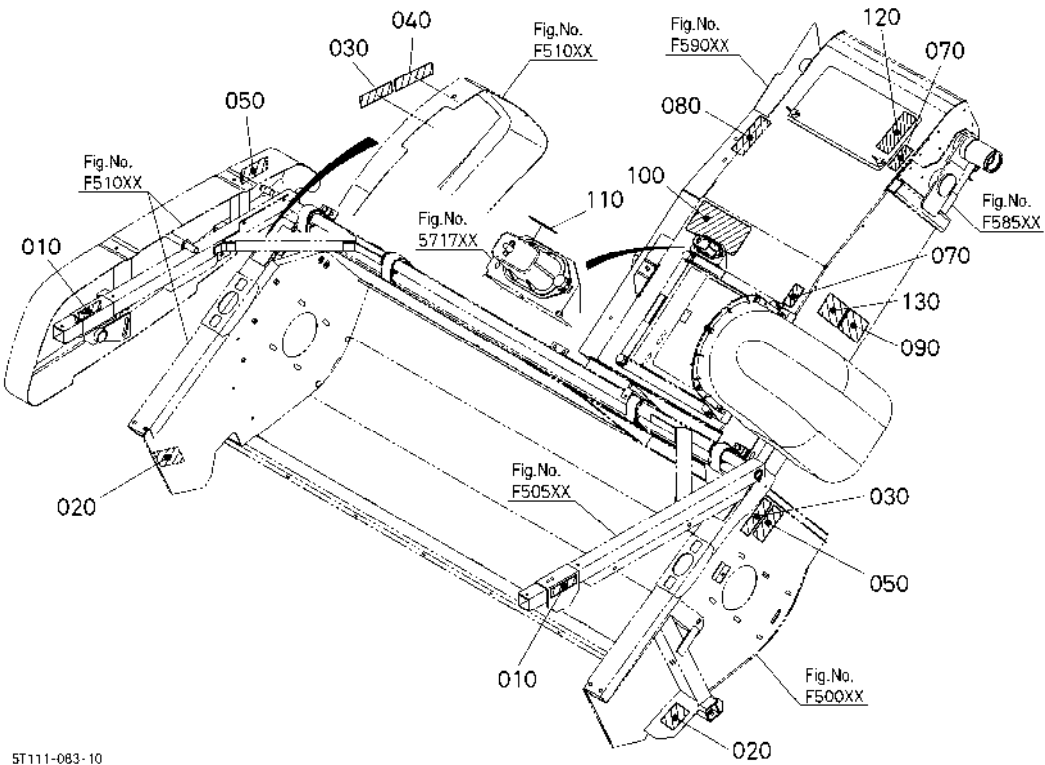

5T111-083-10

A:DC-68G HARVESKING-REEL/FEEDER

REF.No.	PART No.	PART NAME	Q'TY/S.No.	I.C.	REMARKS
			A		
010	5T111-4352-0	LABEL(CAUTION,REEL)	2		
020	5T111-4353-0	LABEL(CAUTION,BLADE,	2		
030	5T111-4354-0	LABEL(HARVEST, CLOGG	2		
040	5T111-4368-0	LABEL(CAUTION)	1		
050	5T111-4355-0	LABEL(WARNING)	2		
060	----	BLANK	-		
070	5T019-4361-0	LABEL,CAUTION	2		
080	5T111-4368-0	LABEL(CAUTION)	1		
090	5T019-4351-0	LABEL	1		
100	5T111-4414-0	LABEL,CAUTIONBREAKER	1		
110	5T078-4413-0	LABEL	1		
120	5T111-4441-0	LABEL(COVER CHECK)	1		
130	5T111-4442-0	LABEL(CHAIN,ADJUST)	1		

↔ Interchangeable; ≠ not Interchangeable; ← new for old; → old for new

N11500 LABEL(THRESHING)

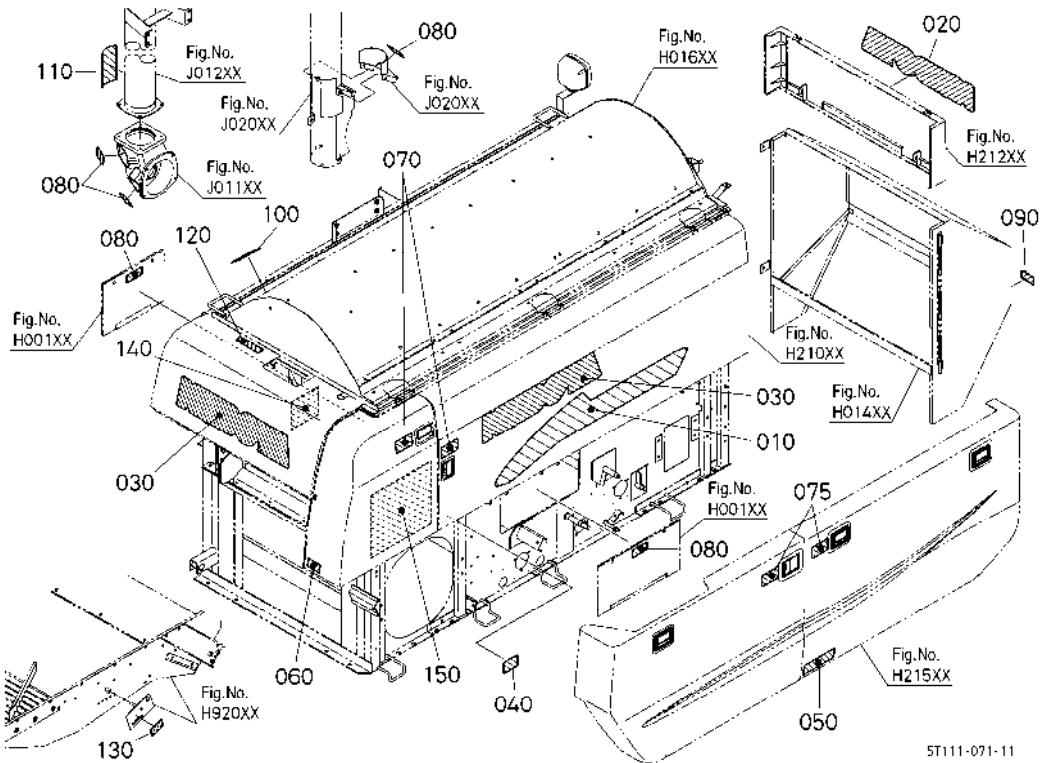

5T111-071-11

A:DC-68G HARVESKING-THRESHING

REF.No.	PART No.	PART NAME	Q'TY/S.No.	I.C.	REMARKS
			A		
010	5T111-4373-3	MARK(D,DC-68G)	1		
020	5T072-4375-2	MARK D,KUBOTA RED	1		
030	5T072-4388-2	MARK,D KUBOTA WHITE	2		
040	5T019-4382-0	LABEL	1		
050	5T111-4368-0	LABEL(CAUTION)	1		
060	5T111-4362-0	LABEL,CAUTION	1		
070	5T111-4366-0	LABEL,LOCK HANDLE	2		
075	5T111-4367-0	LABEL,LOCK HANDLE B	2		
080	5T019-4361-0	LABEL,CAUTION	5		
090	5T019-4365-0	LABEL,CAUTION	1		
100	5T019-4364-0	LABEL	1		
110	5T019-4363-0	LABEL	1		
120	5T111-4369-0	LABEL,CAUTION	1		
130	5T019-4397-0	LABEL	1		
140	5T019-4425-0	LABEL(WATER SEPARATO	1		
150	5T111-4427-0	LABEL(BELT,MAINTENANCE)	1		

↔ Interchangeable; ≠ not Interchangeable; ← new for old; → old for new

N12500 LABEL (GRAIN TANK)

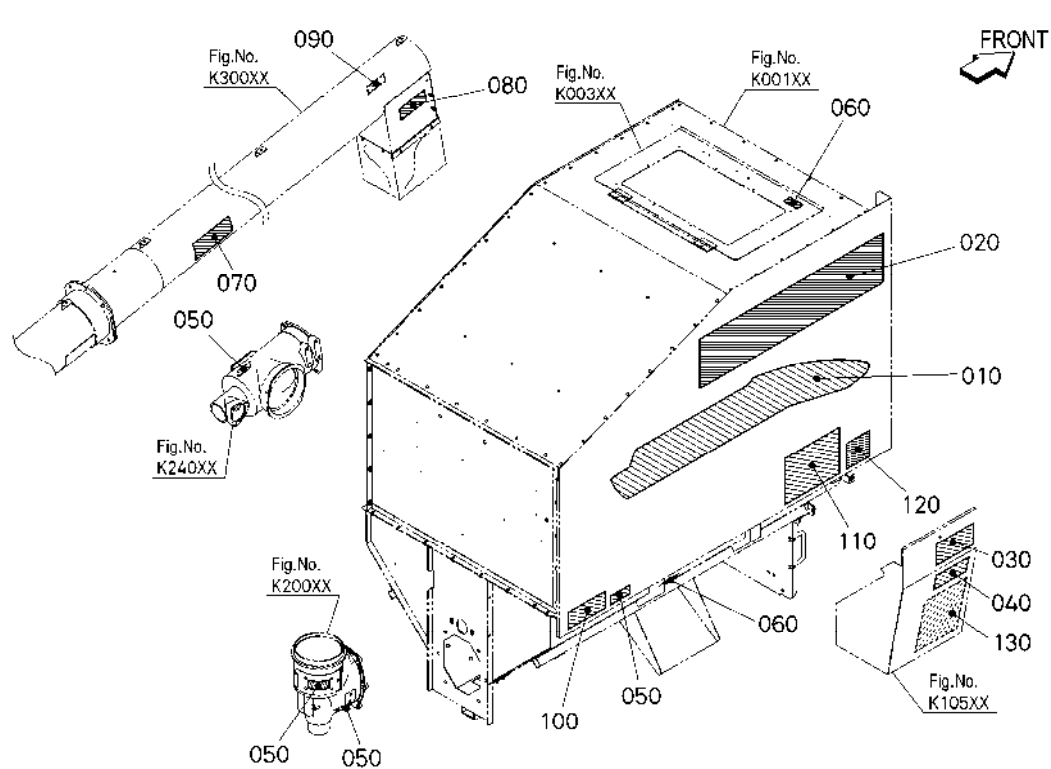

5T111-072-11

A:DC-68G HARVESKING-GRAIN TANK

REF.No.	PART No.	PART NAME	Q'TY/S.No.	I.C.	REMARKS
			A		
010	5T111-4383-3	MARK(G,DC-68G)	1		
020	5T072-4384-0	MARK,KUBOTA	1		
030	5T111-4387-2	LABEL(TANK)	1		
040	5T111-4368-0	LABEL(CAUTION)	1		
050	5T019-4361-0	LABEL,CAUTION	4		
060	5T111-4362-0	LABEL,CAUTION	2		
070	5T019-4389-0	LABEL,UNLOADER	1		
080	5T019-4393-0	LABEL,CAUTION	1		
090	5T019-4394-0	LABEL	1		
100	5T019-4388-0	LABEL	1		
110	5T111-4423-0	LABEL(OVER HEAT)	1		
120	5T019-4428-0	LABEL(WATER)	1		
130	5T111-4424-0	LABEL(OIL,MAINTENANCE)	1		

↔ Interchangeable; ≠ not interchangeable; ← new for old; → old for new

R10000 ACCESSORIES 1

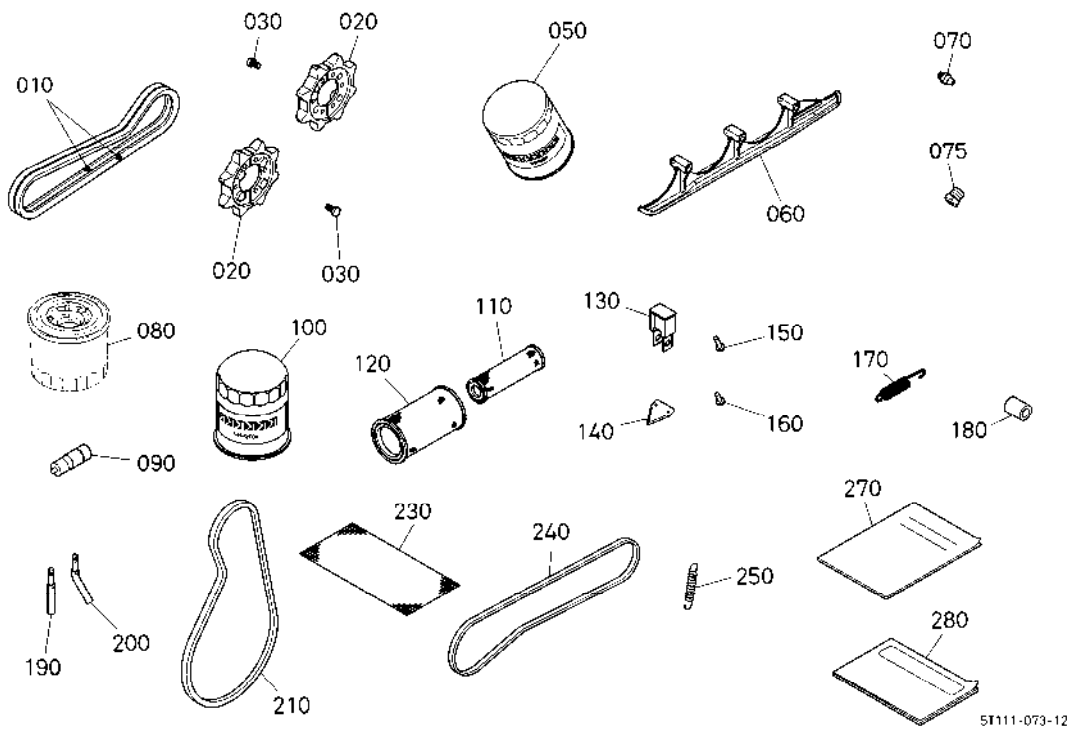

5T111-073-12

A:DC-68G HARVESKING

REF.No.	PART No.	PART NAME	Q'TY/S.No.	I.C.	REMARKS
			A		
010	5T111-1142-0	BELT,V	2		
020	5T070-1645-5	ROLLER,DRIVE	2		
030	5H601-1648-0	BOLT	6		
040	---	BLANK	-		
050	HHK70-1407-0	FILTER(OIL)	1		
060	5T110-2342-2	GUIDE(CRAWLER REAR)	1		
070	06613-10675	NIPPLE,GREASE	20		
075	T2050-8473-0	BLEEDER	5		
080	15221-4317-0	ELEMENT,FILTER	1		
090	5H484-3139-2	BULB	2	55W	
100	HH164-3243-0	FILTER(CARTRIDGE,OIL)	1		
110	5T057-2612-0	ASSY ELEMENT,INNER	1		
120	5T057-2611-0	ASSY ELEMENT,OUTER	1		
130	5T079-4250-0	FUSE	1		
140	5T072-5133-0	CUTTING BLADE	10		
150	5T072-5137-0	RIVET	4		
160	5T072-5138-0	RIVET	8		
170	5T072-5466-2	SPRING,REEL	1		
180	5T072-5544-2	ROLLER,REEL	4		
190	5T072-6324-0	TOOTH THRESHING,STR.	3		
200	5T072-6325-0	TOOTH THRESING	3		
210	5T078-6465-0	BELT,V	2		
220	---	BLANK	-		
230	5T057-7152-0	NET,GRAIN SIEVE	1		
240	5T072-8117-0	BELT,V	1		
250	5T072-8116-0	SPRING,TENSION	1		
260	---	BLANK	-		
270	5T111-8511-0	MANUAL,OP	1		
280	5T111-8512-0	LIST,PARTS(DC-68G-IN2)	1		

↔ Interchangeable; ≠ not interchangeable; ← new for old; → old for new

R10100 ACCESSORIES 2

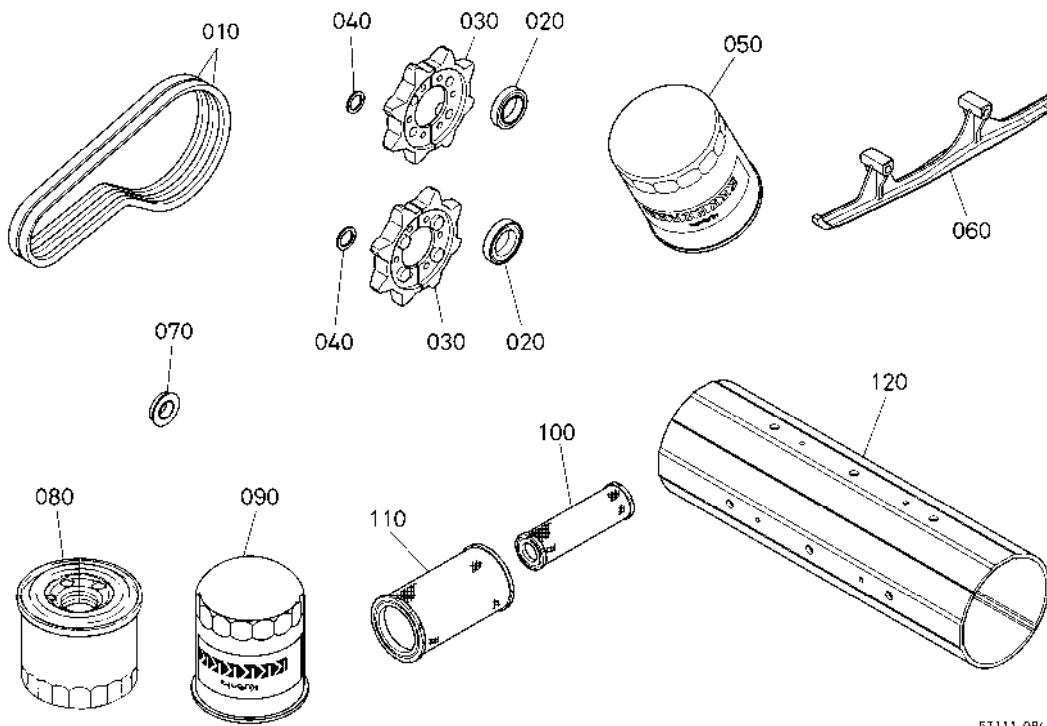

5T111-084-10

A:DC-68G HARVESKING

REF.No.	PART No.	PART NAME	Q'TY/S.No.	I.C.	REMARKS
			A		
010	5T078-1157-0	V BELT,COUNTER	2		
020	TD250-2756-0	SEAL,OIL	2		
030	5T070-1645-5	ROLLER,DRIVE	2		
040	5H801-1649-0	PACKING (17-26)	2		
050	HHK70-1407-0	FILTER(OIL)	1		
060	5T110-2341-0	GUIDE,CRAWLER FRONT	2		
070	52200-2314-2	SEAL,OIL	8		
080	15221-4317-0	ELEMENT,FILTER	1		
090	HH164-3243-0	FILTER(CARTRIDGE,OIL)	1		
100	5T057-2612-0	ASSY ELEMENT,INNER	1		
110	5T057-2611-0	ASSY ELEMENT,OUTER	1		
120	5T091-4661-0	COVER,FEEDER-SHAFT	1		

↔ Interchangeable; ≠ not Interchangeable; ← new for old; → old for new

NUMERICAL INDEX

PART No.	PAGE	REF.No.	PART No.	PAGE	REF.No.	PART No.	PAGE	REF.No.	PART No.	PAGE	REF.No.
HH164-3243-0	6	010	TD250-2756-0	83	170	01025-50616	154	120	01123-50825	182	020
	214	100		215	020		156	020		183	140
	215	090	YR484-1517-0	106	080		156	040	01123-50828	9	080
HHK70-1407-0	79	090	YR700-0315-0	106	090		161	030	01123-50840	73	060
	214	050	YT011-0019-0	108	030		162	080		85	160
	215	050	YT011-0020-0	108	040		163	060		85	240
K7001-3962-0	77	040	YT082-5111-0	110	110		163	120	01123-50845	174	150
K7561-1118-0	77	080	YT102-5131-0	106	100		178	030		175	160
	78	180	YT104-2101-0	110	240		180	070	01123-50860	129	110
MR002-3031-0	110	180	YT107-0048-0	110	100		189	200		130	050
PG001-6218-0	152	060	YT232-0072-0	108	050	01025-50616	192	050	01123-50895	73	050
PL501-6885-0	49	050	YT450-0022-0	110	030		195	090	01123-51020	135	060
	208	220	YT637-0012-0	108	060		200	070	01123-51025	113	040
PP501-7529-0	97	050	YT637-0013-0	108	070		201	160		113	100
PR005-9532-0	62	045	YT637-0014-0	108	080		205	180	01123-51030	80	160
T0070-1642-0	27	050	YT637-0015-0	108	090		205	200	01123-51230	202	020
T1060-3037-0	44	080	YT637-0016-0	108	100		208	210		205	020
	56	130	YT665-0013-0	106	110	01025-50620	27	240	01123-51235	60	110
T1060-3227-0	27	230	YT680-1019-0	106	120		45	020	01123-51240	141	020
	45	010	YW030-0010-0	105	010		46	020	01125-50816	60	030
T1060-3227-0	48	010	YW030-0010-0	106	010	01025-50620	50	020	01125-50816	63	105
	189	190	YW077-0061-0	110	130		120	210		63	120
T1065-1561-0	41	120	YW226-0112-0	110	090		146	150		65	190
T1065-1566-0	41	230	YW226-0510-0	110	250		150	088		145	070
T1275-1563-0	41	130	YW315-0071-0	110	200		153	150		145	090
T1850-3901-0	1	210	YW315-0072-0	110	220		201	180		158	020
T2050-2416-0	136	050	YW599-0010-0	107	010	01027-50616	39	090		182	140
	136	160		108	010		64	140		187	040
T2050-8473-0	87	120	YW600-0010-0	109	010	01053-50610	197	017		191	015
	87	260		110	010	01053-50612	110	160		191	030
T2050-8473-0	88	120	01023-50612	45	070	01123-50801	73	040	01125-50816	191	050
	88	260		59	040	01123-50814	14	140		191	120
	89	180		69	150	01123-50816	3	020		192	110
	90	180		146	130		40	150		194	020
	93	110		191	150		105	050		194	110
	94	110	01023-50616	62	170		181	090		195	030
	214	075		105	070		181	110		195	060
TA043-6404-0	41	090		186	150		181	180		196	170
TC220-5840-0	75	080		193	100		185	070		197	140
	76	070		206	080		189	260		202	090
TC402-3411-0	116	100	01023-50630	118	120	01123-50816	199	070	01125-50816	202	190
	123	030	01023-50650	8	030	01123-50820	80	150		202	230
TC402-3412-0	121	090	01025-50612	37	100		85	090		202	250
	122	080		37	130		107	020		204	130
	144	130		45	040		108	020		205	150
TC402-6838-0	52	060		63	060		132	050		208	110
	53	040		63	150		174	190	01125-50820	27	020
	126	120		120	130		174	210		27	170
	206	140		205	070		175	230		29	030
TC402-7425-0	22	070		205	220		175	250		30	110
TC403-2899-0	118	050	01025-50616	46	080	01123-50822	5	035	01125-50820	30	130
	119	110		48	020		25	040		33	110
	208	040		49	020	01123-50825	9	070		37	070
TC420-5897-0	77	070		49	040		51	080		37	160
TC422-8863-0	39	080		57	070		85	250		44	050
TC422-8864-4	39	030		64	130		135	210		51	020
TC422-8865-0	39	040		110	230		138	160		52	020
TC422-8868-0	39	070		122	220		144	150		62	020
TC432-4939-0	89	160		122	240		174	040		62	040
	90	160		153	120		175	050		62	060

NUMERICAL INDEX

PART No.	PAGE	REF.No.	PART No.	PAGE	REF.No.	PART No.	PAGE	REF.No.	PART No.	PAGE	REF.No.
01125-50820	62	080	01125-50820	178	050	01133-51030	167	100	01754-50620	17	130
	62	100		178	120		196	200	01754-50625	20	090
	62	130		178	180		197	020	01754-50655	23	020
	63	020		179	080		205	090	01754-50660	21	030
	63	040		180	030	01133-51035	150	160	01754-50665	21	040
	64	020		180	040		171	170	01754-50800	97	040
	64	050		180	110	01133-51040	193	220	01754-50812	2	050
	64	170		180	190	01133-51075	139	030		73	100
	65	035		183	150		140	050	01754-50816	10	080
	65	250		189	050	01133-51225	207	100		10	140
01125-50820	67	040	01125-50820	189	180	01133-51230	143	060	01754-50816	124	090
	70	170		193	180	01133-51235	147	040	01754-50820	14	200
	70	190		200	050		147	080		16	120
	72	165		202	210		193	030		21	060
	72	180		203	160	01133-51240	27	100	01754-50825	22	030
	98	100		203	240		167	080		131	200
	98	110		206	020	01133-51640	129	030	01754-50830	20	080
	109	030		207	120		144	020	01754-50835	21	160
	111	050	01125-50825	125	015		144	070	01754-50840	14	190
	115	030		162	060	01135-51020	136	020		96	140
01125-50820	117	150	01125-50825	188	100	01135-51020	201	080	01754-50855	24	110
	120	050	01125-50830	34	040	01135-51025	125	050		40	130
	121	020	01125-50835	64	090		126	060	01754-50865	33	120
	121	110	01125-50850	109	040		135	170		95	100
	122	190	01125-50855	202	200		153	047	01754-50875	21	080
	124	080	01125-50860	190	020		171	030	01754-51040	78	110
	125	090	01125-50865	34	020		172	020		78	190
	125	110		109	050		201	020		80	020
	127	026	01127-50816	151	027		201	100	01754-51055	78	120
	130	065		178	110		201	110	01754-51240	73	160
01125-50820	130	080	01127-50820	64	030	01135-51030	142	110	01774-51020	13	050
	130	110		64	070		154	020	01774-51070	40	030
	133	040		118	170	01135-51040	113	130	01774-51225	61	050
	133	070		127	020	01135-51230	27	120	01811-50812	153	090
	134	290		127	040		60	130		154	050
	134	320		137	250	01138-51030	153	030		154	070
	139	060		158	040	01153-50812	24	160		154	090
	139	090		162	020	01153-50816	72	105	01811-50815	145	020
	139	110		162	100	01155-50840	138	190	01820-50615	69	110
	140	020		164	075	01155-50855	133	170		162	085
01125-50820	140	100	01127-50820	201	040	01155-50855	133	250	01820-50815	161	120
	144	110	01127-50830	40	040	01173-51020	148	130		195	020
	144	170	01128-50820	84	180		164	080	01952-00616	187	070
	152	030	01133-51020	65	150	01173-51635	171	150	01952-00825	180	080
	152	100		128	060	01175-51055	138	020	02012-50060	148	060
	153	020		133	165		138	060		148	100
	153	070		133	245	01311-10812	143	100	02014-50060	117	040
	153	126		135	080	01513-50822	96	130		148	070
	157	020		139	020		146	030		148	110
	157	050		140	040	01517-51640	153	050	02021-50050	161	060
01125-50820	159	020	01133-51020	164	030	01518-50822	22	040	02021-50050	195	100
	159	040		164	110	01754-50610	10	120	02021-50060	56	100
	159	045	01133-51025	28	120	01754-50612	31	080		65	050
	160	020		71	020	01754-50616	1	180		175	270
	160	050		128	030		15	110		183	120
	160	080		128	080		16	180		187	090
	161	110		131	240		20	040		189	090
	164	180		167	040		22	060		189	160
	173	020	01133-51030	42	020	01754-50620	1	200		192	090
	175	140		164	060		4	150		194	050

NUMERICAL INDEX

PART No.	PAGE	REF.No.	PART No.	PAGE	REF.No.	PART No.	PAGE	REF.No.	PART No.	PAGE	REF.No.
02021-50060	194	070	02121-50080	177	040	02751-50080	37	140	04011-50180	128	120
	194	090		180	090		52	050		135	120
02054-50050	146	080		183	050		55	030		150	110
02056-50060	17	117		183	080		55	050		150	170
	40	050		186	020		64	060	04011-50200	113	070
02072-50120	150	075		189	070		122	060		132	090
02114-50080	27	070		189	120		124	070		132	150
	27	150		189	220		131	210		149	040
	33	130		189	240		164	077	04011-50220	166	030
	42	040		199	040		205	250		170	060
02114-50080	95	120	02121-50080	206	130	02751-50080	205	270	04012-50060	179	070
	124	050	02131-50100	133	130	02761-50040	18	170	04013-50040	192	030
	133	180		133	210	02761-50050	59	070	04013-50050	146	060
	133	260		172	040		191	180		146	100
	136	100		172	060	02761-50060	181	050	04013-50060	69	070
	166	110	02156-50080	96	150		206	100		110	150
	174	070		118	160	02763-50080	174	155		116	090
	175	080	02172-50140	52	100		192	070		120	150
	176	180		116	040	02771-50100	42	030		123	020
	184	090	02172-50180	128	140		51	160		146	170
02114-50080	191	080	02172-50180	135	140	02771-50100	147	070	04013-50080	24	140
02114-50100	131	130		136	230	02810-50060	155	040		30	070
02116-50100	107	040		150	130		155	080		70	080
02118-50100	118	030		150	190		178	130		84	190
	118	060	02174-50120	121	220	02810-50080	187	020		95	110
	118	090		174	130	03004-50614	69	080		105	090
	119	040		175	190	03016-50616	183	100		121	080
	119	060		181	160		187	060		122	090
	119	080		185	120		189	140		122	180
	119	120		196	080	03017-50816	152	120		133	190
02118-50100	119	140	02174-50140	121	160	03024-50310	57	040	04013-50080	134	270
	122	120		141	110	03024-50416	49	060		138	200
	126	080		149	110		208	230		152	130
	129	080	02174-50160	89	170	03024-50512	146	050		155	020
	132	130		90	170	03024-50520	18	140		155	060
	133	140		164	160	03034-50310	46	170		159	120
	133	220		164	230		69	130		191	100
	138	040		168	110	03034-50406	210	230		193	060
	138	080		170	110	03034-50520	47	020		208	060
	148	030	02174-50200	117	120		63	250	04013-50100	113	045
02118-50100	149	190	02176-50120	61	100	03034-50525	50	040	04013-50100	139	040
	201	120		72	140		201	200		140	060
	205	100		74	050	03034-50620	56	150		149	170
	208	050	02176-50140	87	090	03054-50510	5	090		153	045
02121-50080	27	030		87	230	03614-50410	68	070		201	130
	27	220		88	090	04011-50100	110	140	04013-50120	60	100
	44	100		88	230	04011-50120	117	053		174	110
	53	030		93	080		208	140		175	170
	54	030		94	080	04011-50140	120	020		193	090
	64	100	02552-50060	146	160		121	170		193	140
02121-50080	65	120	02552-50080	30	080	04011-50140	184	030	04013-50140	52	080
	68	050	02751-50060	4	190	04011-50160	72	040		116	020
	103	100		15	130		87	140	04013-50180	136	215
	125	030		15	170		88	140	04015-50060	59	050
	126	110		17	150		129	040		117	020
	130	120		60	060		136	060		178	140
	134	300		60	080		136	190		183	110
	138	210	02751-50080	16	140		149	210		187	080
	145	050		21	090		170	090		189	150
	153	190		22	050		193	210		191	160

NUMERICAL INDEX

PART No.	PAGE	REF.No.	PART No.	PAGE	REF.No.	PART No.	PAGE	REF.No.	PART No.	PAGE	REF.No.
04015-50060	193	105	04512-50140	88	220	04611-00620	135	050	04612-00400	89	060
	206	090		93	070		135	200		90	060
04015-50080	27	130		94	070		138	150		142	020
	72	100		141	100		150	050		168	050
	111	040	04512-50160	89	150		186	060	04612-00420	207	050
	122	050		90	150		196	180	04612-00500	171	090
	174	050		144	080		202	060	04612-00680	83	070
	175	060		164	150	04611-00680	197	080	04612-01000	152	070
	177	035		164	220		197	110	04711-00060	197	015
	199	060		168	100		203	050	04717-00810	73	110
04015-50100	65	160	04512-50160	170	100	04611-00680	203	210	04717-01000	80	100
	129	060		171	140	04611-00720	78	040		98	070
	133	160	04512-50180	128	130		78	090		167	050
	133	167		135	130		164	036	04717-01200	73	090
	133	240		136	220	04611-00800	142	050		95	050
	133	247		150	120		168	035	04724-00140	15	060
04015-50120	27	110		150	180		171	120	04810-00600	114	090
	61	080	04611-00170	79	060	04611-00850	83	130	04810-50900	89	100
	147	050	04611-00220	97	060	04611-00900	89	080		90	100
	196	060	04611-00350	75	110		90	080	04811-00710	33	050
04015-50160	144	030	04611-00350	76	100	04611-00900	168	030	04811-06630	74	020
	171	130		142	080	04612-00100	106	020		78	150
04512-50050	146	090		151	060	04612-00120	121	210	04811-10090	110	210
04512-50060	20	070		176	107	04612-00140	121	060	04811-10300	11	160
	40	060		184	057	04612-00150	151	030		95	080
	117	030	04611-00360	78	170		152	050	04811-10500	96	120
04512-50080	24	150	04611-00420	131	073		176	110	04811-10850	14	170
	27	060		141	040		176	150	04811-50650	78	030
	27	140		176	140		184	040		78	080
	42	050		186	080		184	060	04811-50900	167	110
04512-50080	96	160	04611-00420	205	050	04612-00160	72	050	04811-51350	167	030
	118	150		205	140	04612-00170	136	130	04814-00060	15	050
	174	060	04611-00450	78	060		149	080	04814-00150	18	040
	175	070	04611-00470	80	050		166	070	04814-00160	2	060
	191	090		84	140		170	050	04814-06310	15	150
04512-50100	118	080		174	030		207	070	04815-50650	73	150
	119	090		174	180	04612-00200	132	030	04816-00070	148	080
	126	070		175	040		176	070		148	120
	129	070		175	220		202	150	04816-50300	74	120
	131	120		176	050		203	110	04816-50350	168	180
04512-50100	133	150	04611-00470	186	120	04612-00200	203	140	04817-00090	7	040
	133	230		188	050	04612-00220	166	040	04817-00100	21	190
	138	030		188	090		170	070		75	045
	138	070	04611-00520	75	040	04612-00250	14	180		106	030
	148	020		76	040		75	120	04817-00110	77	100
	149	180		135	110		96	050		96	090
	201	140		181	080		121	130		106	040
04512-50120	61	090		182	090		135	240	04817-00120	79	070
	72	130		185	060		138	130		84	060
	74	040		202	130		143	040	04817-00140	96	070
04512-50120	121	230	04611-00520	204	100	04612-00250	186	110	04817-00140	96	110
	174	120	04611-00550	196	130		204	080		110	190
	175	180	04611-00620	81	060	04612-00280	81	130	04817-00160	106	050
	181	150		82	030	04612-00300	135	220		110	120
	185	110		87	060		186	050	04817-00180	77	140
	196	070		87	200		202	070	04817-00200	106	060
04512-50140	83	230		88	060	04612-00320	51	120	04817-00220	110	170
	87	080		88	200	04612-00350	168	220	04817-05160	110	080
	87	220		93	050		198	050	04817-06450	83	180
	88	080		94	050	04612-00400	83	150	04817-50300	80	180

NUMERICAL INDEX

PART No.	PAGE	REF.No.	PART No.	PAGE	REF.No.	PART No.	PAGE	REF.No.	PART No.	PAGE	REF.No.
04817-50300	...	95...030	05712-00535	...	80...130	08101-06305	...	93...040	08511-01510	...	184...020
04817-50550	...	112...050	05712-00720	...	10...060			94...040	08511-01620	...	72...030
05012-00408	...	1...080			40...080	08101-06307	...	168...150	09230-20426	...	141...060
05012-00410	...	97...030	05712-00730	...	11...130			168...200	09318-88085	...	33...030
05012-00609	...	1...090			168...250	08101-06308	...	89...050	09318-88150	...	5...020
05012-00612	...	1...100	05712-00735	...	135...160			90...050	09318-88200	...	31...110
		4...030			138...100			168...020	09318-89016	...	38...060
05012-00818	...	73...070			164...130	08141-06001	...	121...190	09318-89020	...	38...050
		85...170			164...200			182...080	09318-89045	...	38...035
		85...260	05712-00740	...	128...110	08141-06004	...	176...020	09318-89050	...	38...030
05012-01018	...	1...110	05712-00745	...	150...020	08141-06004	...	205...040	09318-89055	...	29...050
05122-50614	...	33...060	06111-52023	...	103...015			205...130	09318-89087	...	29...090
		116...080			103...080	08141-06005	...	186...100	09318-89115	...	29...080
		120...145			105...020			188...080	09500-25428	...	186...070
05122-50625	...	122...140			107...070	08141-06006	...	196...110	09500-25477	...	80...070
05122-50845	...	206...040			111...060			198...020	09500-26528	...	182...060
05122-51240	...	103...040	06112-53033	...	96...060	08141-06007	...	196...150	09500-30478	...	188...020
05122-51645	...	149...130	06114-52023	...	107...050			198...040	09500-30528	...	182...050
05411-00414	...	17...100	06311-25020	...	77...090	08141-06008	...	197...070	09500-45689	...	168...170
		77...050	06311-25040	...	77...130			197...100	09503-58011	...	168...230
05411-00528	...	24...120	06331-35010	...	80...090	08141-06008	...	202...160	09661-40030	...	19...040
05411-00620	...	32...020	06331-35012	...	73...080			203...040	09661-40140	...	19...030
05411-00625	...	84...090	06331-45010	...	98...080			203...200	09661-40150	...	19...100
05511-50215	...	70...090			167...060			204...060	09661-40300	...	19...010
		105...100	06331-45012	...	95...040	08141-06202	...	142...070	09661-70220	...	16...020
		122...170	06611-15010	...	144...060			170...040	11460-6311-0	...	43...100
		159...110	06613-10675	...	72...070	08141-06203	...	166...060	11460-6312-0	...	43...230
		193...070			87...110			170...040	11460-6327-0	...	43...110
		208...070			87...250			183...070	11460-6350-0	...	43...060
05511-50425	...	193...150			88...110			189...110	12101-2362-0	...	80...110
								193...200			
05511-50430	...	117...057	06613-10675	...	88...250	08141-06204	...	80...040	13961-8421-0	...	80...140
		120...030			89...120			132...020	13963-9201-0	...	43...260
		136...070			89...240			147...030	14182-9203-0	...	41...260
		136...200			90...120			174...020	14301-4275-0	...	16...030
		149...140			90...240			175...030	14911-4275-0	...	34...060
		208...150			93...100			176...040			34...080
05511-50435	...	132...100			94...100			188...040			34...110
		132...160			166...015			196...030			34...160
		149...050			182...040	08141-06205	...	135...100	14971-4275-0	...	34...140
05511-50440	...	70...140			184...015			204...090	15021-1424-0	...	24...190
05511-50535	...	113...080	06613-10675	...	197...013	08141-06206	...	135...040	15101-3358-0	...	98...020
05511-50550	...	113...120			200...040			135...190	15108-4329-0	...	35...070
05511-51612	...	120...160			201...050			138...140	15108-4361-0	...	35...040
05511-51615	...	122...150			203...090			142...100	15108-4378-0	...	35...050
		179...060			204...020			143...070	15221-1398-0	...	24...050
05515-50800	...	206...050			214...070			150...040	15221-2336-0	...	11...170
05515-51200	...	103...050	06616-35010	...	111...030			202...050	15221-4317-0	...	35...020
05515-51600	...	89...220	07715-00401	...	10...040	08141-06208	...	142...040			214...080
		90...220			11...100			08141-06209			215...080
		103...030	07715-00403	...	14...110	08141-06302	...	131...072	15221-5623-0	...	20...050
05525-50600	...	33...070	07715-01605	...	84...030	08141-06302	...	141...030	15221-6641-0	...	20...060
05525-51200	...	70...210	07715-03205	...	14...090	08141-06303	...	174...170	15224-4301-0	...	34...030
05712-00410	...	8...050	08101-06204	...	84...130			175...210			35...010
05712-00525	...	14...040	08101-06206	...	81...040	08141-06304	...	202...120	15224-4320-0	...	35...030
		174...090			186...040			203...020	15224-8776-0	...	35...080
		175...090	08101-06209	...	168...160			203...180	15248-6370-0	...	46...150
		175...120	08101-06305	...	87...050	08141-06305	...	143...030			63...230
		185...090			87...190			08143-06300	15261-9601-0	...	3...100
		196...050			88...050	08241-05205	...	76...020	15331-5135-0	...	16...060
05712-00530	...	181...130			88...190			96...040	15331-9666-0	...	16...070

NUMERICAL INDEX

PART No.	PAGE	REF.No.	PART No.	PAGE	REF.No.	PART No.	PAGE	REF.No.	PART No.	PAGE	REF.No.
15425-6339-0	43	150	19202-1658-0	75	020	1J860-3314-0	1	150	1J864-2437-0	10	110
15425-6340-0	43	030	19212-6310-0	43	090	1J860-3352-0	31	120	1J864-2516-0	13	030
15434-3326-0	98	010	19212-9713-0	43	220	1J860-9665-0	16	090	1J864-3311-0	1	160
15449-7415-0	23	010	19222-4328-0	35	060	1J864-0175-0	3	010	1J864-3365-0	1	120
15451-9539-0	85	060	1A021-2319-2	11	115	1J864-0337-0	3	080	1J864-3366-0	19	130
15461-7411-0	23	030	1A021-5416-0	15	010	1J864-0338-0	1	060	1J864-3515-0	8	020
15511-9666-0	43	240	1A021-5613-3	20	020	1J864-0339-0	1	070	1J864-3568-0	8	060
15521-9602-0	1	020	1A021-6001-7	15	140	1J864-0345-0	3	130	1J864-3642-0	7	020
	79	020	1A021-7301-2	21	170	1J864-0349-0	3	090	1J864-3655-2	7	030
15521-9603-0	1	030	1A021-9602-0	21	020	1J864-0414-0	12	220	1J864-3693-0	4	110
15841-9151-0	15	120	1A091-0436-2	9	040	1J864-0430-0	4	050	1J864-3695-0	4	100
15841-9602-0	3	170	1A091-1235-0	26	020	1J864-0446-0	9	090	1J864-4201-0	16	010
15881-6409-0	41	150	1A091-1236-0	26	030	1J864-0454-0	9	020	1J864-4241-0	16	040
15881-6415-0	41	280	1A091-2347-2	11	180		9	110	1J864-5132-0	16	080
15881-6426-0	41	080	1A091-2391-0	11	180		9	140	1J864-5166-0	1	170
15881-6433-0	41	160	1A091-2392-0	11	180		9	170	1J864-5214-0	16	170
15881-6471-0	41	060	1A228-7409-0	40	095	1J864-0456-0	9	190	1J864-5344-0	18	050
15881-6480-0	41	100	1A228-7428-0	40	070	1J864-0475-0	4	070	1J864-5345-0	18	070
15881-9104-0	41	200	1A228-7429-0	40	100	1J864-0481-0	9	050	1J864-5362-0	18	030
15881-9105-0	41	220	1A228-7469-0	40	120	1J864-0482-0	9	060	1J864-5373-0	18	100
15881-9201-0	41	030	1A228-7493-0	40	110	1J864-0485-0	4	090	1J864-5385-0	18	120
15881-9202-0	41	250	1A301-0102-0	1	010	1J864-1311-0	24	010	1J864-5386-0	18	130
15881-9301-0	41	070	1C010-1356-0	3	120	1J864-1312-0	24	020	1J864-5412-0	17	020
15881-9302-0	41	210	1E013-3501-3	8	010	1J864-1315-0	24	060	1J864-5427-0	15	070
15881-9303-0	41	180	1G292-7411-0	146	110	1J864-1324-0	24	030	1J864-5435-0	17	010
15881-9304-0	41	190	1G311-4310-0	36	020	1J864-1333-0	24	040	1J864-5545-0	14	060
15951-3311-3	74	110	1G311-4325-0	36	080	1J864-1361-0	3	160	1J864-5547-0	14	070
16221-7327-0	21	150	1G311-4334-0	36	015	1J864-1362-0	3	150	1J864-5569-0	14	080
16241-6490-0	41	240	1G311-4338-0	36	060	1J864-1403-3	24	170	1J864-5574-0	14	100
16241-9602-0	4	020	1G311-4357-0	36	050	1J864-1423-0	24	180	1J864-5602-0	17	070
16271-9616-0	1	050	1G311-4358-0	36	030	1J864-1431-0	24	100	1J864-5641-0	20	120
16285-6357-0	43	250	1G311-4359-0	36	045	1J864-1435-0	24	090	1J864-5642-0	20	130
16285-9201-0	43	270	1G311-4393-0	36	070	1J864-1443-0	24	130	1J864-5660-0	15	090
16652-6431-0	41	140	1G311-8746-0	36	040	1J864-1462-0	17	050	1J864-5721-0	15	100
16652-6477-0	41	110	1G410-4335-0	34	010	1J864-1555-0	10	010		17	120
16652-6478-0	41	050		36	010	1J864-1627-0	10	070	1J864-5739-0	17	115
17111-9701-0	40	090	1G461-6382-0	13	020	1J864-1651-0	10	050	1J864-5792-0	17	110
17123-6301-6	42	010	1G701-0413-0	4	040	1J864-2131-0	11	030	1J864-5798-0	17	090
	43	010	1G778-5454-0	15	080	1J864-2133-0	11	040	1J864-7292-0	21	050
17123-6302-4	43	180	1G790-0331-2	3	140	1J864-2214-0	11	070	1J864-7332-0	4	130
17123-6303-0	43	130	1G790-0360-2	3	140	1J864-2231-0	11	080	1J864-7333-0	4	140
17123-6304-0	43	070	1G790-0361-2	3	140	1J864-2297-0	11	080	1J864-7334-0	5	060
17123-6307-0	43	040	1G790-0362-2	3	140	1J864-2298-0	11	080	1J864-7336-0	21	130
17123-6308-0	43	020	1G790-0363-2	3	140	1J864-2325-0	11	150		32	040
17123-6314-0	43	170	1G790-5216-2	16	100	1J864-2328-2	11	110	1J864-8813-0	4	170
17123-6320-0	43	140	1G852-6551-2	18	150	1J864-2331-0	11	140	1J864-9103-2	4	060
17123-6326-0	43	120	1G896-1328-0	24	070	1J864-2348-0	9	030	1J864-9152-2	4	180
17123-6332-0	43	210	1G896-1358-0	3	110		9	120		15	160
17123-6338-0	43	160	1G896-3566-0	8	040		9	150		17	140
17123-6350-0	43	050	1G896-3701-2	32	010		9	180	1J864-9153-2	3	030
17123-9331-0	43	190	1G896-3707-2	32	015	1J864-2348-0	11	190	1J864-9153-2	21	070
17123-9332-0	43	200	1G896-5220-0	16	110	1J864-2353-0	11	200	1J864-9154-2	16	130
17214-7202-0	37	020	1G911-1452-3	5	100	1J864-2354-0	12	210	1J864-9155-0	26	040
17311-6328-0	43	080	1G911-5410-0	15	020	1J864-2393-0	11	190	1J864-9201-0	3	040
17369-6757-0	41	270	1G911-5615-0	20	030	1J864-2394-0	11	190		26	050
17391-9616-0	1	040	1G911-9201-0	15	040	1J864-2395-0	11	200		28	040
17539-5203-0	16	160	1G921-1619-0	14	165	1J864-2396-0	12	200	1J864-9581-0	18	025
19077-5209-2	16	100	1G924-2198-0	11	060	1J864-2397-0	12	210	1J864-9673-0	18	060
19077-5211-3	16	100	1J550-5387-0	19	080	1J864-2398-0	12	210	1J872-1182-0	25	030
19077-5212-3	16	100	1J860-2498-2	10	100	1J864-2401-2	10	090	1J872-1426-0	24	080

NUMERICAL INDEX

PART No.	PAGE	REF.No.	PART No.	PAGE	REF.No.	PART No.	PAGE	REF.No.	PART No.	PAGE	REF.No.
1J872-1601-2	10	030	1J881-2301-0	11	090	52200-1628-0	83	080	58600-2523-0	101	060
1J872-4250-0	18	010	1J881-2411-0	11	120	52200-1714-0	84	070		101	080
1J872-5374-0	18	110	1J881-2425-0	10	130	52200-1748-0	107	030		101	100
1J872-9102-0	5	110	1J881-3304-0	31	010	52200-2314-2	87	040		101	120
1J872-9201-0	17	030	1J881-3305-0	31	060		87	180	59700-1148-0	72	110
1J872-9665-0	17	040	1J881-3323-0	31	090		88	040	59700-1555-0	81	080
1J873-0150-0	2	010	1J881-3324-0	31	100		88	180	59700-2625-0	29	060
1J873-0462-0	13	040	1J881-3367-0	31	070		89	070	59700-2766-0	74	090
1J873-0512-0	5	070	1J881-3641-2	7	010		90	070	59700-2767-0	74	100
1J873-0543-0	5	080	1J881-3708-0	6	020		93	030	59800-2813-0	107	060
1J873-0551-0	5	010	1J881-3709-0	6	030	52200-2314-2	94	030	5G046-1128-0	193	130
1J873-0558-0	5	030	1J881-3715-0	32	030		215	070	5G072-1119-0	207	020
1J873-1172-0	2	120	1J881-3716-2	32	060	52200-2516-0	61	060	5G127-7126-0	49	010
1J873-1607-0	14	150	1J881-5101-0	16	050	52200-2676-0	33	080		201	150
1J873-2501-0	13	010	1J881-5115-0	14	030	52270-1514-0	74	070	5G127-7127-0	46	070
1J873-2565-0	22	080	1J881-5136-0	19	120	52270-1534-0	73	120		49	030
1J873-3211-0	2	040	1J881-5175-0	14	020	52270-1621-3	83	010		122	230
1J873-4236-0	19	050	1J881-5300-0	18	020	52270-1623-0	83	020		200	060
1J873-4275-0	19	045	1J881-5371-0	18	080	52270-1713-2	84	050	5G200-1149-0	192	060
	19	060	1J881-5372-0	18	090	52270-1733-0	84	110	5G200-2232-0	207	060
1J873-4275-0	19	110	1J881-5605-0	20	010	52270-1734-0	84	150	5G230-2265-0	197	090
1J873-5700-2	17	060	1J881-6442-2	40	020	52270-1737-0	84	120		203	220
1J873-5715-2	17	080	1J881-7303-0	22	010	52270-1822-2	85	150		204	040
1J873-5748-0	1	190	1J881-7334-0	1	130	52270-1832-4	85	230	5G250-1137-0	59	060
1J873-6057-0	16	150	1J881-7336-0	32	050	52300-7517-0	118	020		191	170
1J873-6556-0	18	160		32	070		119	070	5H215-2579-0	56	120
1J873-7270-0	21	010	1J881-9102-0	28	110	52500-3275-3	124	030		102	030
1J873-7281-0	21	015	1J881-9149-0	26	060	52600-2738-0	95	060	5H400-2591-0	34	137
1J873-7291-0	21	017	1J881-9154-0	28	130	52600-3145-0	117	090		153	160
1J873-7326-0	21	140	1J881-9579-0	31	020	52807-1102-0	75	030	5H400-2675-0	33	040
1J873-7334-2	21	110	1J881-9580-0	31	040	52807-1102-0	76	030	5H400-3294-0	118	100
1J873-7343-0	22	020	1J881-9626-0	25	020	52807-1116-0	77	025	5H400-3296-0	118	130
1J873-8334-0	4	160	1J881-9665-0	31	030	52807-1118-3	78	100	5H470-2710-5	96	010
1J873-8721-0	209	010	1J881-9666-0	31	050	53415-4128-0	63	100		97	010
1J873-9101-0	2	030	1J881-9730-0	14	120		65	070	5H484-3138-2	52	030
1J873-9102-2	4	080	1J883-9154-0	28	030		65	100		53	010
1J881-0304-0	3	070	1K411-6402-0	41	040		66	280		54	010
1J881-0402-0	4	010	1K531-6460-2	41	170		67	030		126	090
1J881-0704-0	9	100	31351-3792-0	110	040		68	020		153	170
1J881-0705-0	9	130	31351-3793-0	110	020		68	090		206	110
1J881-0706-0	9	160	31351-3795-0	110	050	53415-4128-0	68	140	5H484-3139-2	52	040
1J881-0709-0	9	010	31351-3796-0	110	050		68	180		53	020
1J881-1164-0	28	060	31351-3797-0	110	050		69	100		54	020
1J881-1172-0	28	070	34260-3688-0	52	090	53721-5318-0	192	080		55	020
1J881-1173-0	28	080		116	030	53821-2219-0	143	090		126	100
1J881-1177-0	25	010	35890-4129-0	82	020	54513-1427-0	73	035		153	180
1J881-1231-0	26	010	37410-1432-0	81	050	54617-1212-0	74	060		205	240
1J881-1232-0	28	090	3F250-2736-0	87	100		80	170		206	120
1J881-1450-0	5	040		87	240		95	020		214	090
1J881-1511-0	10	020		88	100	54721-3461-0	74	080	5H484-8632-0	176	130
1J881-1602-2	14	010	3F250-2736-0	88	240	55417-5252-0	141	050	5H484-8634-0	181	070
1J881-1632-0	14	130		93	090	55511-2118-3	61	070		182	070
1J881-1701-0	28	010		94	090	55571-3145-0	124	040		185	050
1J881-1710-0	28	020	3F290-6397-0	83	210	55611-3145-0	122	020	5H486-4288-0	46	060
1J881-1711-0	28	100	41071-4114-0	78	160	55611-3146-0	124	020		124	110
1J881-2105-0	11	020	44366-6897-0	27	180	56511-1141-0	80	060	5H491-2520-0	37	010
1J881-2109-0	11	020	50727-4361-2	196	190	58218-1155-0	37	060	5H492-3539-0	65	110
1J881-2111-0	11	010	51601-6218-0	89	140		65	037	5H540-4591-0	51	030
1J881-2190-0	11	010		90	140	58600-2523-0	101	020		103	110
1J881-2201-2	11	050	52000-3143-0	117	110		101	040	5H583-4125-0	45	050

NUMERICAL INDEX

PART No.	PAGE	REF.No.	PART No.	PAGE	REF.No.	PART No.	PAGE	REF.No.	PART No.	PAGE	REF.No.
5H583-4125-0	63	160	5T019-4348-0	210	180	5T051-5919-0	165	260	5T057-2612-0	214	110
5H592-4972-0	151	070	5T019-4351-0	211	090	5T051-6420-0	160	100		215	100
	176	105	5T019-4361-0	211	070	5T051-6525-0	169	260	5T057-2755-0	112	040
	184	055		212	080	5T051-6526-0	169	260	5T057-2759-0	112	030
5H601-1225-0	72	060		213	050	5T051-6724-0	182	110	5T057-2763-0	112	060
5H601-1645-5	83	200	5T019-4363-0	212	110	5T051-6814-0	186	030	5T057-2764-0	112	070
5H601-1648-0	83	220	5T019-4364-0	212	100	5T051-6861-0	186	130	5T057-3256-0	118	110
	214	030	5T019-4365-0	212	090	5T051-6912-0	174	080	5T057-4211-0	46	010
5H601-1713-0	84	040	5T019-4382-0	212	040		175	100		120	200
5H601-1731-2	84	100	5T019-4387-0	210	200	5T051-6914-0	174	100	5T057-4223-0	46	040
5H601-2119-0	63	015	5T019-4388-0	213	100	5T051-7625-0	59	030	5T057-4223-0	46	050
5H601-2423-2	87	070	5T019-4389-0	213	070		191	140		64	180
	87	210	5T019-4393-0	213	080	5T051-9127-2	168	120		64	190
	88	070	5T019-4394-0	213	090	5T054-7885-0	51	040	5T057-4224-2	46	090
	88	210	5T019-4395-0	210	250	5T054-7886-0	51	050		63	170
	93	060	5T019-4397-0	212	130	5T054-7887-0	51	060	5T057-4228-0	50	030
	94	060	5T019-4425-0	212	140	5T054-7888-0	51	070		201	190
5H601-4194-0	21	180	5T019-4426-0	210	260	5T054-7952-0	114	080	5T057-5421-0	103	010
5H630-1011-0	75	050	5T019-4428-0	213	120	5T055-7829-0	199	020		104	010
5H630-1012-2	75	070	5T050-3956-2	73	037	5T055-7833-0	196	090	5T057-6214-0	153	110
5H630-1051-0	76	060	5T050-4650-3	148	040	5T055-7834-0	196	140	5T057-6868-0	189	210
5H630-1070-2	77	020	5T050-4651-3	148	050	5T055-7842-0	198	030	5T057-7152-0	214	230
5H630-1072-2	77	060	5T050-4652-3	148	090	5T055-8128-0	113	025	5T070-1511-0	73	010
5H630-1080-0	77	110	5T050-5926-0	146	040	5T055-8129-0	113	020	5T070-1512-2	73	020
5H630-1090-3	78	130	5T050-5943-0	57	020	5T055-8141-0	114	020	5T070-1513-0	73	030
5H630-1095-0	79	030	5T050-6621-0	164	090	5T055-8142-0	114	030	5T070-1543-0	81	020
5H632-1538-0	80	080	5T051-1051-0	171	080	5T055-8143-0	114	040	5T070-1612-2	82	090
5H632-2713-0	96	030	5T051-1052-0	171	110	5T055-8144-0	114	050	5T070-1616-0	82	110
5H632-3253-0	116	060	5T051-1216-0	95	070	5T055-8145-0	114	060	5T070-1617-0	82	120
5H658-1632-0	83	110	5T051-2545-0	29	070	5T055-8146-0	114	070	5T070-1635-0	85	110
5H658-1643-2	83	140	5T051-2572-2	33	090	5T055-8172-2	202	040	5T070-1635-0	85	190
5H663-1537-3	80	030	5T051-2620-0	30	010	5T055-8174-2	202	110	5T070-1645-5	214	020
5H669-4250-0	40	010	5T051-2621-0	30	020		203	100		215	030
	41	010	5T051-2622-0	30	030		203	130	5T070-1663-0	85	100
5H672-1629-0	83	040	5T051-2623-0	30	040	5T055-8175-0	203	010	5T070-1664-0	85	180
5H730-4251-0	41	020	5T051-2624-0	30	050	5T055-8177-0	202	140	5T070-1743-0	85	120
5H746-1148-0	72	090	5T051-2625-0	30	060	5T055-8179-0	203	120		85	200
5H746-2712-0	97	020	5T051-2626-2	30	090	5T055-8182-2	203	170	5T070-1744-0	85	130
5H801-1549-0	74	030	5T051-2673-2	33	100	5T055-8184-0	204	070		85	210
5H801-1551-0	81	010	5T051-2676-0	33	020	5T055-8193-2	50	010	5T070-1753-0	85	030
5H801-1647-0	83	250	5T051-2712-0	96	100	5T055-8193-2	201	170	5T070-1755-0	85	140
5H801-1648-0	83	260	5T051-3117-0	120	190	5T056-4202-2	46	100		85	220
5H801-1649-0	83	240		210	070		63	180	5T070-3152-0	120	140
	215	040	5T051-3118-0	120	180	5T056-4222-2	46	110	5T070-3254-3	122	070
5H844-1766-0	85	010	5T051-3226-0	117	010		63	190	5T070-4637-0	136	120
5H844-1771-0	85	020	5T051-3232-0	117	060	5T056-4225-0	46	130		149	070
5H852-1618-0	82	100	5T051-4327-0	210	060		63	210	5T070-4638-0	136	135
5H852-1767-0	85	040	5T051-4371-2	210	220	5T056-4227-0	46	140		149	075
5H852-1768-0	85	050	5T051-4640-0	149	010		63	220	5T070-7530-0	46	160
5H861-1624-0	83	050	5T051-4645-0	136	034	5T056-4242-0	46	120		69	120
5K101-3157-0	188	070	5T051-4645-0	149	012	5T056-4242-0	63	200	5T070-7924-0	202	170
5K101-3159-0	186	090	5T051-4646-0	149	014	5T057-1085-0	149	030		203	030
5K101-3169-0	188	060	5T051-4931-0	136	036	5T057-1088-0	144	050	5T070-8173-0	202	100
5K190-5122-0	182	010	5T051-4941-0	136	144	5T057-2215-0	89	190	5T071-3138-2	55	010
5T019-2671-0	33	010	5T051-4942-0	136	146		90	190		205	230
5T019-4322-0	210	040	5T051-5433-0	104	020	5T057-2610-2	29	010	5T071-5111-0	142	010
5T019-4326-0	210	050	5T051-5434-0	104	030	5T057-2611-0	29	017	5T071-6521-0	168	040
5T019-4338-0	210	100	5T051-5435-0	104	040		214	120	5T071-6522-0	168	140
5T019-4343-0	210	160	5T051-5614-0	116	110		215	110	5T071-6523-0	168	210
5T019-4344-0	210	170	5T051-5919-0	162	120	5T057-2612-0	29	015	5T071-7951-0	113	010

NUMERICAL INDEX

PART No.	PAGE	REF.No.	PART No.	PAGE	REF.No.	PART No.	PAGE	REF.No.	PART No.	PAGE	REF.No.
5T071-7951-0	114	010	5T072-3555-0	69	040	5T072-5116-0	142	090	5T072-5522-0	128	040
5T071-7955-0	113	090	5T072-3556-0	69	050	5T072-5121-0	141	010		128	090
5T071-7956-0	113	110	5T072-4113-0	44	030	5T072-5125-0	141	070	5T072-5523-0	128	050
5T071-8183-3	203	230	5T072-4114-2	44	040	5T072-5126-0	141	080	5T072-5535-0	128	100
5T072-1141-3	72	010	5T072-4115-0	44	090	5T072-5127-0	141	090	5T072-5541-0	129	010
5T072-1144-0	72	080	5T072-4116-0	44	060	5T072-5133-0	131	040	5T072-5543-0	129	020
5T072-1149-0	72	120	5T072-4126-0	34	135		214	140	5T072-5544-2	129	050
5T072-1151-0	72	150		54	040	5T072-5134-0	131	050		214	180
5T072-1152-0	72	160		56	140	5T072-5135-0	131	060	5T072-5553-0	129	090
5T072-1213-3	95	130		60	040	5T072-5136-0	131	070		130	030
5T072-1214-2	95	140	5T072-4126-0	60	090	5T072-5137-0	131	080	5T072-5554-2	129	100
	192	140		99	020		214	150		130	040
5T072-1635-0	136	090		101	045	5T072-5138-0	131	090	5T072-5561-2	130	060
5T072-2116-0	27	190		102	020		214	160	5T072-5581-0	130	090
5T072-2123-0	98	030		103	130	5T072-5141-0	131	100	5T072-5582-0	130	100
5T072-2174-0	62	090		153	200	5T072-5142-0	131	110	5T072-5641-0	167	010
5T072-2179-0	62	120		156	090	5T072-5144-0	131	150	5T072-5642-0	168	190
5T072-2565-0	46	030		158	100	5T072-5145-0	131	160	5T072-5647-0	152	090
5T072-2593-0	98	050	5T072-4251-0	45	030	5T072-5146-0	131	170	5T072-5648-0	152	110
5T072-2666-4	27	160		45	060	5T072-5147-0	131	180	5T072-5649-0	167	090
5T072-2843-2	111	020	5T072-4251-0	63	140	5T072-5148-0	131	190	5T072-5650-0	167	070
5T072-2891-0	105	060		69	140	5T072-5149-0	131	220	5T072-6114-0	157	010
5T072-2892-0	105	080	5T072-4261-0	56	060	5T072-5151-0	131	230	5T072-6115-0	157	040
5T072-2995-0	89	200	5T072-4262-0	56	050	5T072-5212-3	133	020	5T072-6116-0	154	047
	90	200	5T072-4263-0	56	040	5T072-5213-2	134	280	5T072-6117-0	157	030
5T072-3128-0	70	110	5T072-4265-0	56	030	5T072-5214-4	133	050		157	060
	116	050	5T072-4371-0	210	210	5T072-5215-0	133	110	5T072-6118-0	154	045
	119	020	5T072-4375-2	212	020	5T072-5216-0	133	120	5T072-6119-0	154	040
	121	050	5T072-4384-0	213	020	5T072-5217-0	133	200	5T072-6131-0	157	035
	123	050	5T072-4385-0	210	190	5T072-5219-2	133	090	5T072-6136-0	161	040
5T072-3128-0	208	160	5T072-4386-0	208	170	5T072-5221-0	135	010	5T072-6136-0	162	040
5T072-3134-0	63	030	5T072-4388-2	212	030	5T072-5222-0	135	030	5T072-6142-0	163	040
5T072-3143-0	117	100	5T072-4533-0	144	090	5T072-5224-0	135	025		163	100
5T072-3224-3	64	110	5T072-4541-3	144	100		135	070	5T072-6164-2	158	060
5T072-3234-2	64	150	5T072-4622-0	143	080	5T072-5225-0	135	090	5T072-6167-0	156	060
5T072-3236-0	122	160	5T072-4636-0	136	110	5T072-5229-0	135	020	5T072-6181-0	156	080
5T072-3237-2	117	080		149	060	5T072-5232-0	135	180		158	090
5T072-3238-2	117	140	5T072-4642-0	136	080	5T072-5234-0	135	230	5T072-6182-0	156	070
5T072-3243-5	117	130	5T072-4643-0	132	120		138	120	5T072-6191-0	154	060
5T072-3257-0	124	010	5T072-4721-0	125	020	5T072-5243-0	138	170	5T072-6192-0	154	080
5T072-3263-2	124	060	5T072-4751-4	139	010	5T072-5244-2	138	180	5T072-6193-0	153	080
5T072-3265-0	116	010	5T072-4752-0	139	070	5T072-5245-0	133	030	5T072-6194-0	153	085
5T072-3277-0	119	010		140	070		133	060	5T072-6195-0	154	085
5T072-3282-0	64	120	5T072-4755-2	139	080		134	310	5T072-6211-0	156	010
5T072-3321-3	124	100	5T072-4761-2	140	030	5T072-5251-0	138	090	5T072-6212-0	156	030
5T072-3322-0	122	200	5T072-4762-0	125	040	5T072-5252-0	138	110	5T072-6213-0	153	100
	184	070	5T072-4811-4	139	100	5T072-5412-0	126	020	5T072-6217-0	154	110
5T072-3512-0	68	010	5T072-4831-4	140	090	5T072-5413-0	126	030	5T072-6218-0	154	130
5T072-3513-2	68	030	5T072-4841-0	139	050	5T072-5414-2	126	040	5T072-6313-0	171	040
5T072-3514-0	68	060		140	010	5T072-5415-0	126	050	5T072-6314-0	171	070
5T072-3516-2	68	040	5T072-4871-0	127	023	5T072-5422-2	103	020	5T072-6315-0	171	050
5T072-3542-0	65	060	5T072-4913-0	143	050	5T072-5427-0	103	090	5T072-6316-0	171	060
5T072-3546-0	65	240	5T072-4921-0	136	010	5T072-5451-0	132	010		185	030
5T072-3548-0	63	130	5T072-4933-0	136	040	5T072-5452-0	132	040	5T072-6317-0	171	100
	65	010	5T072-4935-0	136	180	5T072-5455-0	132	060	5T072-6318-0	171	160
5T072-3549-0	65	020	5T072-4943-0	136	150	5T072-5463-0	132	080	5T072-6324-0	172	030
5T072-3551-7	69	010	5T072-4944-0	136	170		132	140		214	190
5T072-3552-0	69	060	5T072-4945-0	136	240	5T072-5465-0	132	070	5T072-6325-0	172	050
5T072-3553-0	69	020	5T072-5112-0	142	030	5T072-5466-2	132	110		214	200
5T072-3554-0	69	030	5T072-5115-0	142	060		214	170	5T072-6345-0	151	010

NUMERICAL INDEX

PART No.	PAGE	REF.No.	PART No.	PAGE	REF.No.	PART No.	PAGE	REF.No.	PART No.	PAGE	REF.No.
5T072-6348-0	151	020	5T072-6858-0	189	060	5T072-7712-0	193	170	5T072-7974-0	206	060
	176	100	5T072-6862-0	189	020	5T072-7713-0	193	190	5T072-7975-0	206	070
	184	050	5T072-6863-0	189	250	5T072-7714-0	190	010	5T072-7994-0	113	050
5T072-6349-0	151	080	5T072-6865-0	189	130	5T072-7822-0	193	110	5T072-7996-0	196	040
5T072-6387-0	153	130	5T072-6867-0	189	100	5T072-7825-2	193	010	5T072-8113-0	207	010
5T072-6388-0	153	140	5T072-6869-0	189	230	5T072-7828-2	193	080	5T072-8116-0	208	080
5T072-6415-0	159	090	5T072-6911-0	175	010	5T072-7831-0	196	010		214	250
5T072-6417-0	159	060	5T072-6915-0	174	160	5T072-7832-0	196	020	5T072-8117-0	207	080
5T072-6418-2	160	090		175	200	5T072-7836-0	196	210		214	240
5T072-6421-0	160	010	5T072-6916-0	175	110	5T072-7843-0	197	030	5T072-8118-2	208	090
5T072-6422-0	160	030	5T072-6917-0	175	130	5T072-7845-0	196	160	5T072-8125-0	192	120
5T072-6423-0	160	070	5T072-6918-0	174	140	5T072-7846-0	199	050	5T072-8126-0	192	130
5T072-6425-0	159	100		175	150	5T072-7847-0	199	030	5T072-8134-0	208	100
5T072-6427-0	159	080	5T072-6919-0	174	010	5T072-7848-0	191	060	5T072-8135-0	208	200
5T072-6429-0	160	110		175	020	5T072-7849-0	191	070	5T072-8136-2	208	120
5T072-6457-0	176	190	5T072-6926-0	176	060	5T072-7851-5	197	010	5T072-8141-2	208	030
5T072-6515-0	168	010	5T072-6931-0	176	080	5T072-7855-0	197	120	5T072-8171-0	202	030
5T072-6518-0	168	080	5T072-6933-0	176	160	5T072-7857-0	197	130	5T072-8176-0	202	180
5T072-6519-0	164	140	5T072-6934-0	176	170	5T072-7861-2	204	120	5T072-8178-2	203	080
	164	210	5T072-6936-0	176	120	5T072-7868-0	192	010	5T072-8181-2	203	150
5T072-6519-0	168	090	5T072-6937-0	170	020	5T072-7869-2	192	040	5T072-8186-0	203	190
5T072-6524-0	169	260		176	090	5T072-7872-0	194	030	5T072-8861-3	70	060
5T072-6527-0	168	120	5T072-6941-0	174	200	5T072-7875-2	192	100	5T072-8862-0	70	100
5T072-6528-0	168	120		175	240	5T072-7878-0	193	020	5T072-8863-0	70	070
5T072-6529-0	168	120	5T072-7114-0	158	080	5T072-7879-0	193	040	5T072-8865-2	70	180
5T072-6536-0	168	130		180	060	5T072-7887-0	193	120	5T072-8911-0	70	160
5T072-6551-0	167	020	5T072-7116-0	178	020	5T072-7889-2	192	020	5T072-8921-0	70	200
5T072-6572-0	170	080	5T072-7122-0	180	050		210	280	5T072-8931-0	70	130
5T072-6578-0	151	050	5T072-7142-0	178	170	5T072-7892-0	51	010	5T072-9136-0	189	075
5T072-6579-0	166	050	5T072-7145-4	178	150	5T072-7895-0	51	140	5T073-1071-0	168	060
5T072-6579-0	170	030	5T072-7153-0	177	010	5T072-7899-0	51	150	5T076-1735-2	84	160
5T072-6581-0	166	010	5T072-7156-0	177	020	5T072-7913-0	201	030	5T076-1736-2	84	170
5T072-6586-0	166	100	5T072-7157-0	177	030	5T072-7914-2	201	070	5T076-6624-0	164	040
5T072-6587-0	166	020	5T072-7167-0	180	130	5T072-7915-0	51	130	5T077-2752-0	111	010
5T072-6588-0	184	080	5T072-7168-0	180	150	5T072-7921-2	202	010		112	010
5T072-6589-0	166	090	5T072-7169-0	180	140	5T072-7923-0	202	080	5T077-2756-0	112	020
5T072-6619-0	164	070	5T072-7170-0	179	010	5T072-7925-0	202	220	5T077-4930-0	136	030
5T072-6718-0	181	120	5T072-7171-0	179	020	5T072-7931-2	204	010	5T077-4940-0	136	140
5T072-6722-0	181	140	5T072-7172-0	179	040	5T072-7932-0	205	030	5T078-1112-0	27	210
	185	100	5T072-7173-0	179	050	5T072-7933-0	202	240	5T078-1115-0	71	010
5T072-6725-0	182	130	5T072-7174-0	179	030	5T072-7934-0	205	010	5T078-1157-0	71	040
5T072-6728-0	181	040	5T072-7175-0	178	090	5T072-7939-0	205	060		215	010
	183	030	5T072-7177-0	179	025	5T072-7945-0	205	120	5T078-1211-0	95	010
	189	030	5T072-7181-0	178	080	5T072-7947-0	205	170	5T078-1212-0	95	090
5T072-6766-0	183	160		180	160	5T072-7948-0	205	190	5T078-1218-0	27	200
5T072-6767-0	183	170		180	240	5T072-7953-0	113	030	5T078-1219-2	72	170
5T072-6811-0	185	010	5T072-7182-0	178	100	5T072-7954-2	55	040	5T078-2114-3	60	020
5T072-6812-0	186	010	5T072-7214-0	161	050		205	260	5T078-2115-0	60	120
5T072-6813-0	181	060		195	080	5T072-7957-0	113	060	5T078-2129-2	62	140
	185	040	5T072-7216-0	161	080	5T072-7965-0	197	035	5T078-2131-2	62	050
5T072-6815-0	186	140	5T072-7217-0	161	100	5T072-7966-0	196	100	5T078-2132-2	62	110
5T072-6817-0	187	010	5T072-7221-2	162	010		207	030	5T078-2133-3	62	150
5T072-6818-2	185	020	5T072-7222-2	162	030	5T072-7967-0	196	120	5T078-2136-2	27	010
5T072-6825-0	188	015	5T072-7223-0	162	050		207	040	5T078-2139-3	62	160
5T072-6827-0	185	080	5T072-7225-0	162	070	5T072-7968-0	197	040	5T078-2151-0	61	010
5T072-6831-0	187	030		163	050		203	060	5T078-2152-0	61	020
5T072-6832-0	187	050		163	110		203	250	5T078-2153-0	61	030
5T072-6833-0	187	100	5T072-7241-2	162	090	5T072-7969-0	197	060	5T078-2154-0	61	040
5T072-6854-2	188	010	5T072-7244-0	158	050		203	070	5T078-2172-2	62	030
5T072-6856-0	188	030	5T072-7711-0	193	160		203	260	5T078-2173-0	62	070

NUMERICAL INDEX

PART No.	PAGE	REF.No.	PART No.	PAGE	REF.No.	PART No.	PAGE	REF.No.	PART No.	PAGE	REF.No.
5T078-2176-0	60	050	5T078-3591-0	65	260	5T078-5521-2	128	020	5T078-6529-0	168	120
5T078-2177-2	60	070	5T078-3592-0	65	270	5T078-5531-2	128	070	5T078-6571-0	170	010
5T078-2584-2	34	070	5T078-3751-0	65	090	5T078-5551-4	130	010	5T078-6585-0	166	080
5T078-2594-0	98	090	5T078-3752-0	65	200	5T078-5552-4	130	020	5T078-6611-0	164	010
5T078-2656-3	27	040	5T078-3755-2	65	210	5T078-5562-2	130	070	5T078-6613-2	164	020
5T078-2659-0	27	080	5T078-3756-0	65	220	5T078-5613-2	116	120	5T078-6615-2	164	050
5T078-2714-0	14	160	5T078-3757-0	65	230	5T078-5621-0	150	140	5T078-6622-0	164	100
5T078-2731-0	99	010	5T078-4243-3	58	010	5T078-5622-0	143	020	5T078-6623-0	164	065
5T078-2732-2	99	030	5T078-4249-0	40	140	5T078-5623-0	150	150	5T078-6631-0	164	120
5T078-2751-0	100	010	5T078-4253-2	59	020	5T078-5631-0	149	020	5T078-6632-0	164	170
5T078-2752-0	100	020	5T078-4271-0	56	020	5T078-5632-0	149	100	5T078-6633-2	164	190
5T078-2753-0	100	030	5T078-4333-2	56	160	5T078-5633-0	149	120	5T078-6634-0	164	035
5T078-2761-0	111	080		210	080	5T078-5634-0	149	150	5T078-6635-0	164	240
5T078-2762-0	103	120	5T078-4337-2	210	090	5T078-5635-0	149	160	5T078-6711-0	181	010
5T078-2771-2	101	010	5T078-4413-0	211	110	5T078-5636-0	149	200	5T078-6713-0	181	020
5T078-2775-0	101	030	5T078-4511-7	144	010	5T078-5637-0	149	205	5T078-6714-0	181	030
5T078-2778-0	101	050	5T078-4515-0	145	010	5T078-5638-0	149	230	5T078-6715-0	181	100
5T078-2781-0	101	070	5T078-4521-2	145	030	5T078-5643-0	168	240	5T078-6721-0	181	170
5T078-2791-4	102	010	5T078-4522-0	145	040	5T078-5644-0	152	010	5T078-6723-0	182	100
5T078-2846-0	111	070	5T078-4525-0	145	060	5T078-5645-0	152	020	5T078-6729-0	182	120
5T078-2872-2	109	020	5T078-4526-2	145	080	5T078-5646-0	152	080	5T078-6741-0	184	010
5T078-3111-5	63	010	5T078-4531-0	144	040	5T078-5912-2	146	010	5T078-6752-0	183	020
5T078-3113-2	120	010	5T078-4543-3	144	120	5T078-5913-3	146	020	5T078-6753-0	183	040
5T078-3114-0	120	040	5T078-4544-0	25	050	5T078-5914-0	146	033	5T078-6754-0	183	060
5T078-3115-0	120	060		144	125	5T078-5915-0	146	035	5T078-6763-0	183	090
5T078-3119-0	120	070	5T078-4551-0	144	140	5T078-5922-3	146	070	5T078-6768-0	183	180
5T078-3122-0	120	170	5T078-4611-4	150	010	5T078-5928-2	146	120	5T078-6851-0	189	010
5T078-3124-0	123	010	5T078-4612-3	150	060	5T078-5931-0	146	140	5T078-6852-0	189	040
5T078-3127-0	123	040	5T078-4613-0	150	070	5T078-5942-0	57	030	5T078-6853-3	189	080
5T078-3137-0	63	050	5T078-4616-0	144	160	5T078-5944-0	57	060	5T078-6922-0	176	010
5T078-3181-3	121	010	5T078-4617-2	150	090	5T078-5945-0	57	050	5T078-6924-0	176	030
5T078-3182-0	121	120	5T078-4621-2	150	100	5T078-5948-2	146	045	5T078-6951-0	153	060
5T078-3183-0	121	030	5T078-4624-0	150	085	5T078-5949-2	146	047	5T078-7111-3	178	010
5T078-3185-2	121	040	5T078-4625-0	150	086	5T078-5952-0	146	037	5T078-7115-0	180	210
5T078-3186-0	121	180	5T078-4626-0	150	087	5T078-6101-2	154	010	5T078-7124-0	180	010
5T078-3188-0	121	140	5T078-4633-0	148	010	5T078-6102-2	153	010	5T078-7125-0	180	020
5T078-3189-0	121	150	5T078-4638-0	149	220	5T078-6113-0	154	030	5T078-7126-3	180	100
5T078-3191-0	121	200	5T078-4642-0	149	090	5T078-6121-0	155	010	5T078-7127-0	180	120
5T078-3194-0	52	010	5T078-4655-3	147	010		155	050	5T078-7132-0	180	200
5T078-3195-0	52	070	5T078-4656-3	147	020	5T078-6122-0	155	030	5T078-7136-0	178	040
5T078-3222-5	64	040	5T078-4657-3	147	025	5T078-6123-0	155	070	5T078-7137-0	178	060
5T078-3251-0	122	010	5T078-4658-0	147	060	5T078-6163-0	158	010	5T078-7138-0	178	070
5T078-3259-0	122	210	5T078-4711-3	125	010	5T078-6166-0	156	050	5T078-7144-0	180	250
5T078-3292-0	118	010	5T078-4741-2	125	080	5T078-6219-0	154	100	5T078-7154-0	180	170
	119	050	5T078-4742-2	125	100	5T078-6221-0	153	125	5T078-7155-0	180	180
5T078-3295-0	118	040	5T078-4861-0	127	010	5T078-6311-2	171	010	5T078-7211-0	161	010
	119	100	5T078-4865-0	140	080	5T078-6312-0	171	020	5T078-7212-0	161	020
5T078-3297-0	118	140	5T078-4881-0	127	030	5T078-6322-0	172	010	5T078-7213-0	161	090
5T078-3332-0	63	070	5T078-4911-0	143	010	5T078-6347-0	151	025	5T078-7215-0	161	070
5T078-3336-3	63	110	5T078-5132-0	131	030	5T078-6352-0	152	040	5T078-7219-0	161	025
5T078-3352-0	120	090	5T078-5143-0	131	140	5T078-6411-0	159	010	5T078-7219-0	161	130
5T078-3353-0	120	100	5T078-5211-4	133	010	5T078-6412-0	159	030	5T078-7231-2	163	010
5T078-3355-0	120	110	5T078-5228-0	136	210	5T078-6414-0	159	017	5T078-7232-2	163	070
5T078-3365-0	120	120	5T078-5231-0	135	150	5T078-6415-0	159	035	5T078-7235-0	162	110
5T078-3391-0	63	080	5T078-5241-0	138	010	5T078-6416-0	159	050	5T078-7236-0	164	250
5T078-3392-0	63	090	5T078-5242-0	138	050	5T078-6426-0	159	070	5T078-7243-0	175	260
5T078-3543-0	65	080	5T078-5411-3	126	010	5T078-6451-0	173	010	5T078-7824-0	199	010
5T078-3561-2	65	130	5T078-5425-0	103	060	5T078-6465-0	151	040	5T078-7827-0	193	050
5T078-3562-2	65	140	5T078-5426-0	103	070		214	210	5T078-7841-3	198	010
5T078-3563-0	65	170	5T078-5511-0	128	010	5T078-6517-0	168	070	5T078-7878-0	65	040

NUMERICAL INDEX

PART No.	PAGE	REF.No.	PART No.	PAGE	REF.No.	PART No.	PAGE	REF.No.	PART No.	PAGE	REF.No.
5T078-7878-0	194	080	5T110-1682-0	85	080	5T111-2551-0	30	120	5T111-4362-0	213	060
5T078-7891-0	200	010	5T110-1711-0	84	010	5T111-2552-0	30	140	5T111-4366-0	212	070
5T078-7894-0	200	030	5T110-1712-0	84	020	5T111-2553-0	37	120	5T111-4367-0	212	075
5T078-7896-0	51	100	5T110-1715-0	84	080	5T111-2554-0	38	040	5T111-4368-0	211	040
5T078-7897-0	51	110	5T110-2314-2	86	010	5T111-2556-0	38	010		211	080
5T078-7916-4	201	090	5T110-2341-0	91	010	5T111-2557-0	38	020		212	050
5T078-7941-0	205	110		92	010	5T111-2562-0	37	150		213	040
5T078-7943-0	205	080		215	060	5T111-2566-0	37	030	5T111-4369-0	212	120
5T078-7946-0	205	160	5T110-2342-2	91	030	5T111-2568-2	115	020	5T111-4373-3	212	010
5T078-7949-0	205	210		92	030	5T111-2571-0	34	100	5T111-4383-3	213	010
5T078-7961-0	194	040	5T110-2342-2	214	060	5T111-2572-0	34	130	5T111-4387-2	213	030
5T078-7962-0	194	060	5T110-2388-2	89	020	5T111-2581-0	34	050	5T111-4393-0	210	030
5T078-7971-0	206	010		90	020	5T111-2582-0	34	090	5T111-4394-0	210	010
5T078-7972-0	206	030	5T110-2583-0	34	120	5T111-2585-2	34	150	5T111-4395-2	210	020
5T078-8121-0	207	090	5T110-3617-0	79	080	5T111-2634-0	29	020	5T111-4396-2	210	240
5T078-8123-0	207	110	5T111-1142-0	71	030	5T111-2738-0	115	010	5T111-4414-0	211	100
5T079-4247-0	57	010		214	010	5T111-2785-0	101	090	5T111-4421-0	210	150
5T079-4248-3	56	070	5T111-1535-0	80	120	5T111-2788-0	101	110	5T111-4423-0	213	110
5T079-4249-0	56	080	5T111-2111-4	60	010	5T111-3184-0	121	100	5T111-4424-0	213	130
5T079-4250-0	56	090	5T111-2161-2	67	010	5T111-3221-0	64	010	5T111-4427-0	212	150
5T079-4250-0	214	130	5T111-2162-0	67	020	5T111-3225-0	64	080	5T111-4441-0	211	120
5T079-5130-0	131	010	5T111-2171-3	62	010	5T111-3231-0	117	050	5T111-4442-0	211	130
5T079-5131-0	131	020	5T111-2211-2	87	010	5T111-3235-0	117	070	5T111-6751-0	183	010
5T090-1542-0	81	030	5T111-2212-2	87	150	5T111-3253-0	122	030	5T111-6761-2	183	130
5T090-1553-0	81	090	5T111-2213-2	88	010	5T111-3255-0	122	100	5T111-7242-3	158	030
5T091-4661-0	150	080	5T111-2214-2	88	150	5T111-3256-0	122	130	5T111-7810-0	191	010
	215	120	5T111-2312-0	87	030	5T111-3258-0	122	110	5T111-7815-2	191	020
5T096-2527-5	39	010		87	170	5T111-3259-0	117	045	5T111-7816-0	191	040
5T096-2528-2	39	050		88	030	5T111-3285-0	64	160	5T111-7821-0	194	010
5T096-2529-0	39	060		88	170	5T111-3299-0	118	070	5T111-7822-0	194	100
5T096-2530-2	39	020	5T111-2312-0	93	020	5T111-3311-2	119	130	5T111-7831-0	191	130
5T110-1020-0	78	020		94	020	5T111-3513-0	68	080	5T111-7833-2	191	110
5T110-1030-0	78	070	5T111-2313-2	87	020	5T111-3514-0	68	100	5T111-7893-2	200	020
5T110-1100-2	74	010		87	160	5T111-3516-0	68	120	5T111-7911-0	201	010
	75	010		88	020	5T111-3517-0	68	130	5T111-7915-0	195	040
	76	010		88	160	5T111-3518-0	68	150	5T111-7963-0	195	010
	77	010		93	010		68	150	5T111-7977-0	195	050
	78	010		94	010	5T111-3521-0	68	190	5T111-7978-0	195	070
	79	010	5T111-2314-0	87	130	5T111-3522-0	68	200	5T111-8136-0	208	240
5T110-1521-0	73	130		88	130	5T111-3523-0	68	170	5T111-8138-0	208	010
5T110-1522-2	73	140	5T111-2325-0	89	210	5T111-3524-0	37	080	5T111-8139-0	208	020
5T110-1536-0	80	010		90	210	5T111-3525-0	37	090	5T111-8511-0	214	270
5T110-1552-0	81	070	5T111-2349-0	91	020	5T111-3541-3	65	030	5T111-8512-0	214	280
5T110-1554-0	81	110		92	020	5T111-3544-2	65	180	5T121-8811-0	70	010
5T110-1555-0	81	100	5T111-2384-4	89	010	5T111-3545-2	65	185	5T121-8871-0	70	120
5T110-1556-0	81	150		90	010	5T111-3559-0	69	090	5T121-8941-0	70	150
5T110-1557-0	81	140	5T111-2385-3	89	030	5T111-3561-0	37	040	62151-4241-2	119	030
5T110-1558-0	81	120		90	030	5T111-3563-0	37	050	66363-3924-0	75	100
5T110-1565-0	82	040	5T111-2386-0	89	090	5T111-4121-0	47	010		76	090
5T110-1566-0	82	010		90	090		63	240	66363-3925-0	75	090
5T110-1567-0	82	050	5T111-2394-0	89	230	5T111-4241-0	56	010	66363-3925-0	76	080
5T110-1568-0	82	060		90	230	5T111-4245-0	59	010	66363-3949-0	78	050
5T110-1569-0	82	070	5T111-2395-2	89	130	5T111-4246-0	56	110	66363-3971-0	79	040
5T110-1611-0	82	080		90	130	5T111-4334-2	210	110	66363-3972-0	79	050
5T110-1641-0	83	090	5T111-2396-0	89	040	5T111-4342-0	210	130	66415-8386-0	77	120
5T110-1642-2	83	100		90	040	5T111-4352-0	211	010	66611-3633-0	106	070
5T110-1643-0	83	185	5T111-2399-0	89	110	5T111-4353-0	211	020	68171-6363-0	98	040
5T110-1645-0	83	160		90	110	5T111-4354-0	211	030	68728-7615-0	96	080
5T110-1646-0	83	190	5T111-2546-0	29	040	5T111-4355-0	211	050	69191-6329-0	105	040
5T110-1681-0	85	070	5T111-2549-0	30	100	5T111-4362-0	212	060	6A000-3982-0	78	140

NUMERICAL INDEX

PART No.	PAGE	REF.No.	PART No.	PAGE	REF.No.	PART No.	PAGE	REF.No.	PART No.	PAGE	REF.No.
6A110-3515-0		75			060						
		76			050						
6A610-3533-0		77			030						
70244-5638-0		121			070						
7C765-5126-0		204			110						