

*Laser Cutting, CNC Bending, Power Press, Shearing,
Injection Moulding, Powder Coating, Spray Painting, Welding etc.*

J.B.H. AUTOMATICS

Introducing **J.B.H. AUTOMATICS...**

- We have the pleasure to introduce ourselves with your expertise business and to meet your expected level of cost, quality and delivery for the industries.
- Automobile Industry is one of the most fast moving field in the present competitive markets. Visualizing its fast place growth and development, we **J.B.H. AUTOMATICS**, potential manufacturer and supplier of Machined, Sheet Metal Fabricated Assy, Rubber & Plastic Parts
- Mfg:- Tools, Moulds, Drilling Fixture, Receiving Gauge, Standard Gauge, Welding Fixture & All Kinds of Tool Room Works.
- Automotive Components
- Non Automotive Components
- Rubber & Plastic Parts



our Plant & Machinery...

- Laser Cutting Machine
- CNC Bending Machine
- Shearing Machine
- Power Press - 5 Ton to 75 Ton
- MIG Welding Machine / TIG Welding Machine
- Imported Plastic Injection Moulding Machine
- Powder Coating Plant (Coating Thickness Gauge/ PH Tasting Meter/ TDS Meter/ Conductivity Meter
- Spray Paint Booth Room (Air Filter Chamber) HOT Air Oven / Air Compressor / Air Dryer
- Spray Paint Tasting Lab (SST Chamber / Dust Chamber / Penetration Resistance / Rigidity Tester / IMPACT And Penetration Testing Equipment / Humidity Chamber / UV+ Water Flow Chamber / Dynamic Test Retention System)
- Traub Machine A32 / A25 (5 Nos.) / Turning Adda
- Milling Machine
- Buffing Machine / Grinding Machine



LASER CUTTING

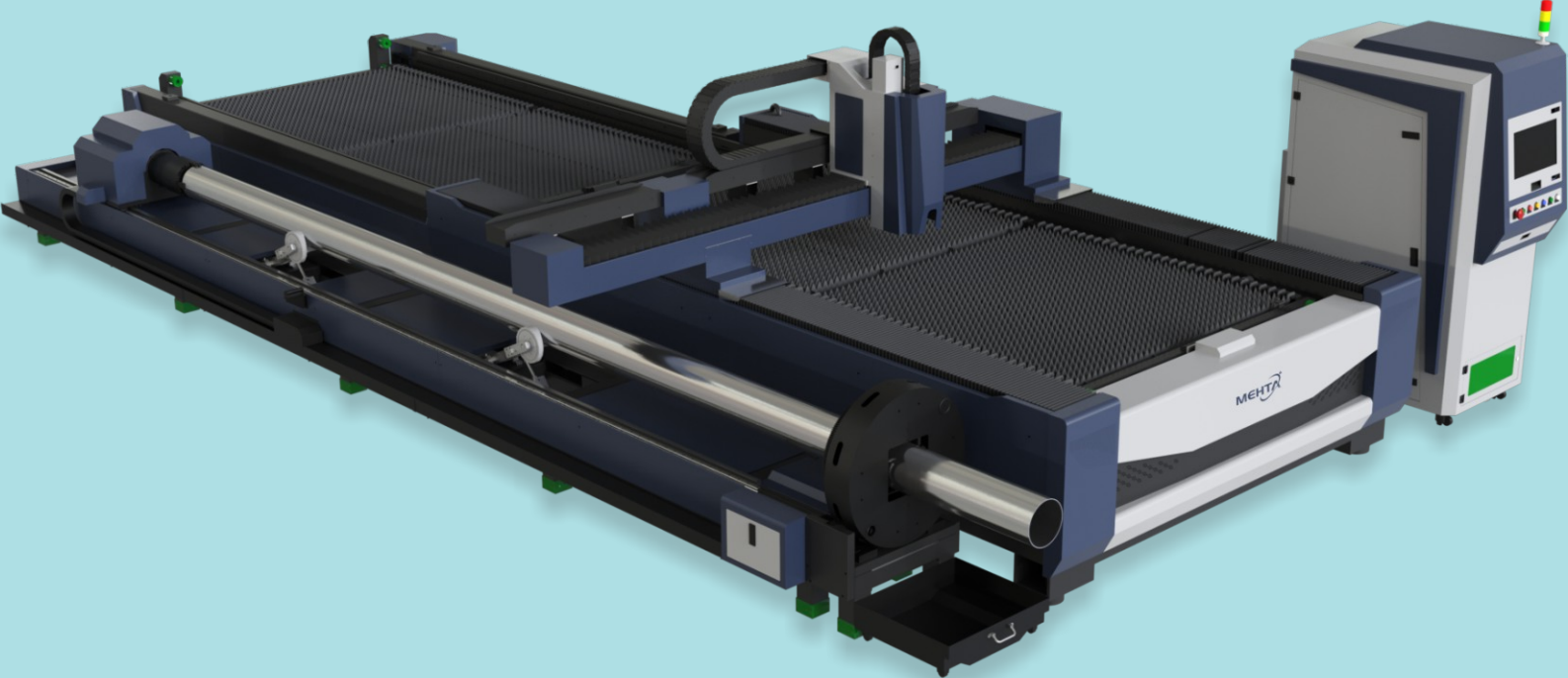

**4AXIS
CNC BENDING**



- **MOULDS**
We offer a wide range of expertise in the design, building all type of moulds like Hot Runner Moulds, Pattern, Tools, Gauge, Jigs & Fixtures, Insert Moulds etc.

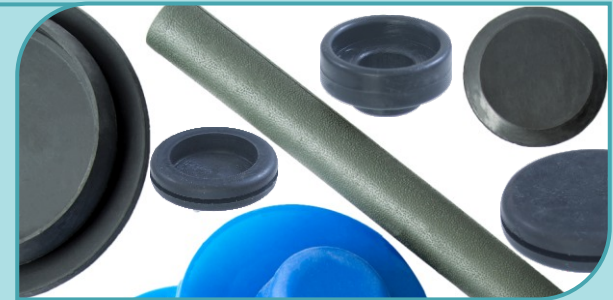
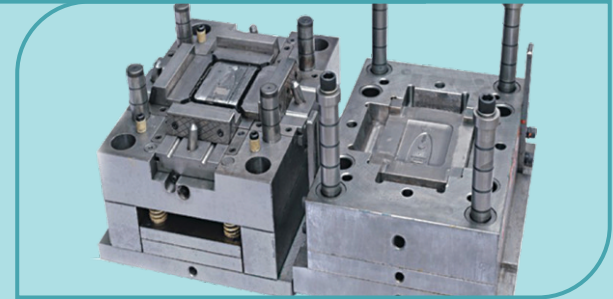
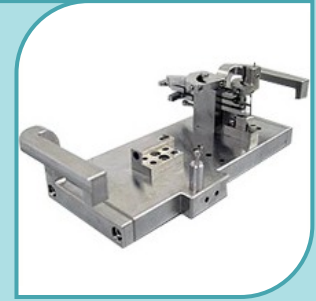

PLASTIC & RUBBER PARTS

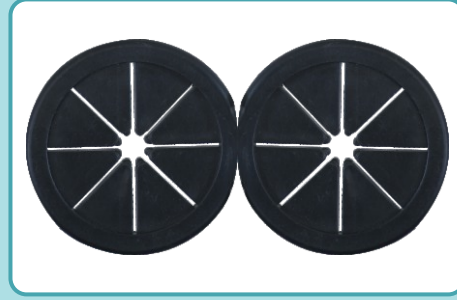
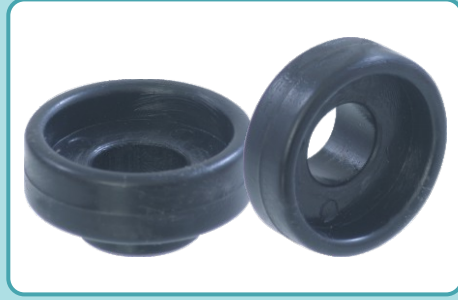
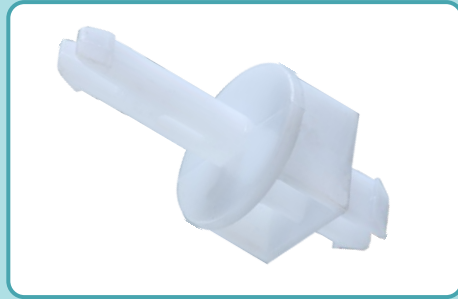



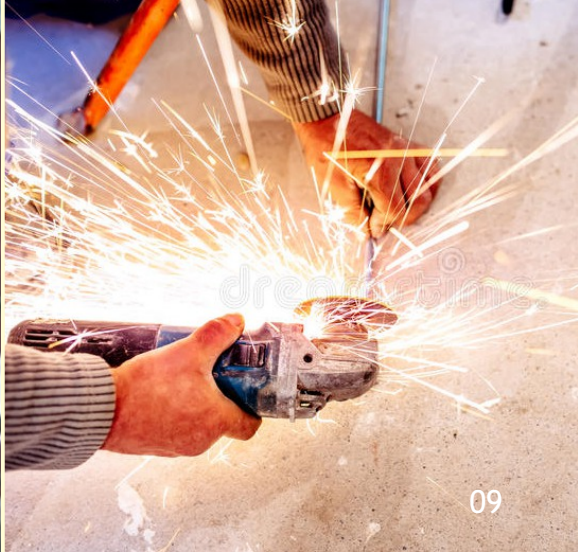

SPRAY PAINTING



POWDER COATING

SPRAY PAINTING

MATERIAL : Metal Parts, Plastic Parts, ABS Parts, Nylon Parts, PP CP, Fiber Parts, Wooden Parts etc. as per requirements



LASER / BENDING / WELDED PARTS

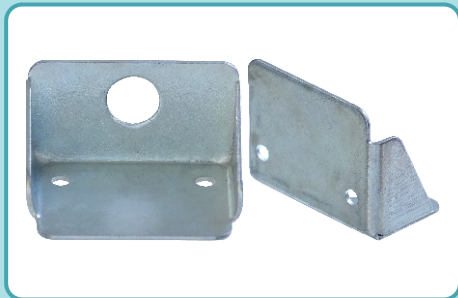

- **CUSTOMIZED SPECIAL PANEL**
MATERIAL : GPSP

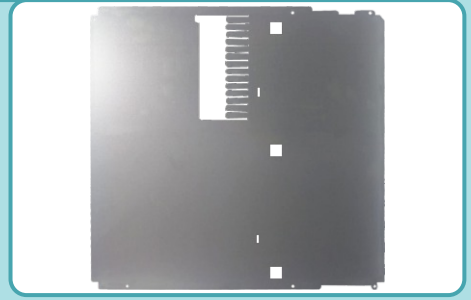

- **CUSTOMIZED SPECIAL PANEL**
MATERIAL : GPSP

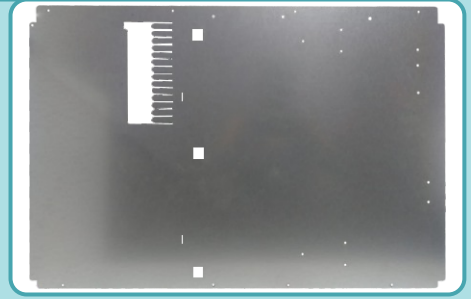

- **CUSTOMIZED SPECIAL PANEL**
MATERIAL : GPSP

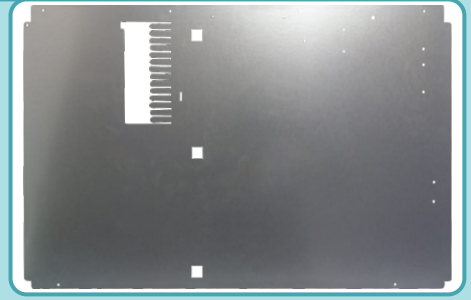

LASER / POWER PRESS PARTS

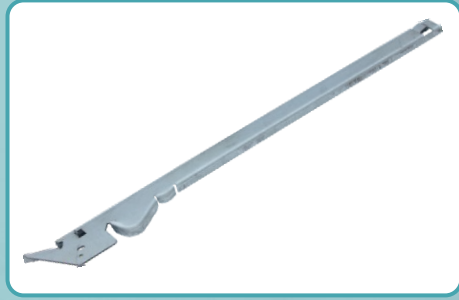
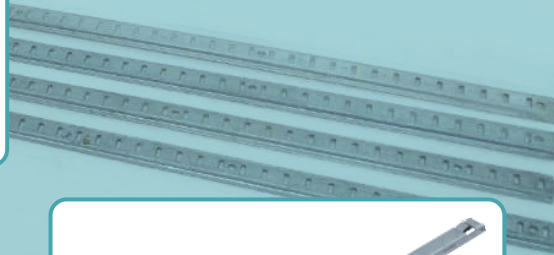
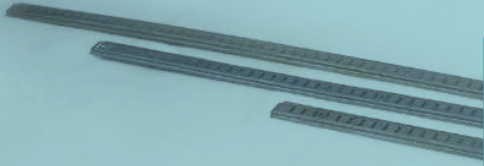
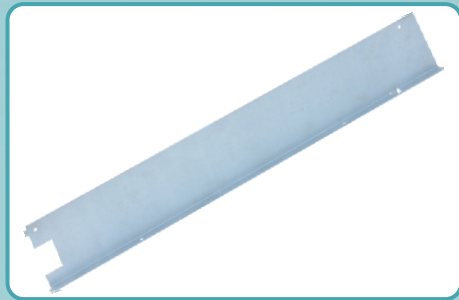
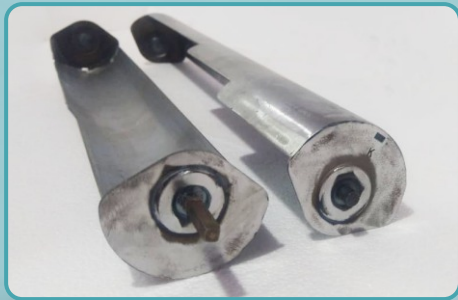

- **ALUMINUM CASTING PART**
MATERIAL : LM25



- **DOOR STOPPER / ROPE**
MATERIAL : COATED STEEL WIRE ROPE

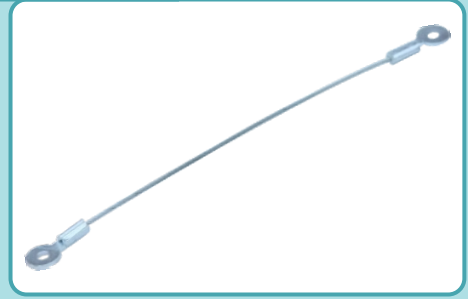

- **CUSTOMIZED PIANO HINGES**
MATERIAL : STAINLESS STEEL

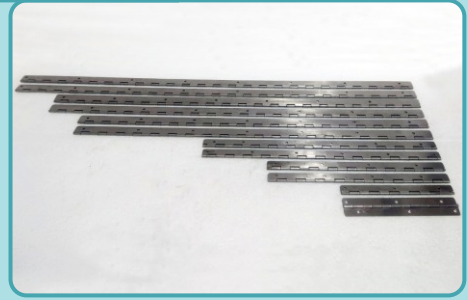

CUSTOMIZED PARTS

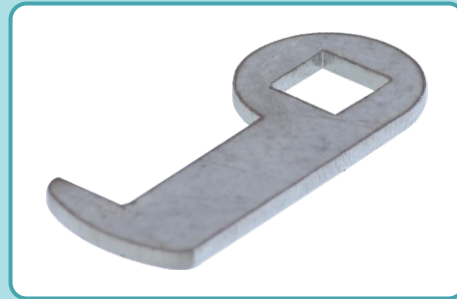

CUSTOMIZED MACHINED PARTS

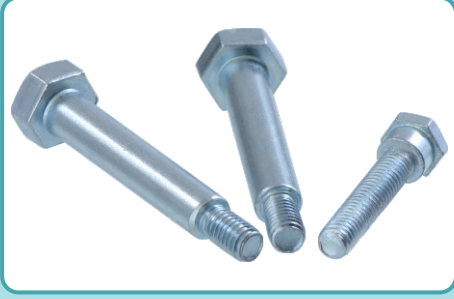
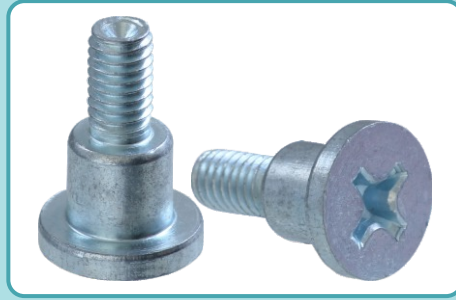
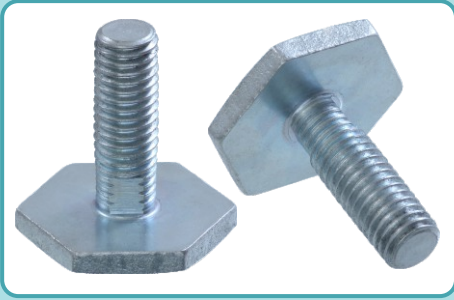

MACHINED / FORGED PARTS



- **SPRING DOWEL PIN (HOLLOW TYPE) (MS/SS)**
 - STANDARDS : DIN 1481, 7346, ISO 13337, 8752
 - DIAMETER : 1.5mm to 36mm
 - MATERIAL : Heat Treated Spring Steel & Stainless Steel
 - FINISH : Black & Steel Finish



- **CUSTOMIZED SPECIAL TUBULAR PARTS**
 - MATERIAL : Carbon steel, Stainless steel
 - FINISH : Zinc Plating



- **SLOTTED & CASTLE NUTS (MS/SS)**
 - STANDARDS : DIN 935
 - DIAMETER : 6mm to 48mm, 3/8" to 1.1/2"
 - GRADES : cl 6, cl 8, cl 10, 2H, A2, A4
 - FINISH : Black, Zinc Blue, Hot Dip, Decromate, Yellow Passivation

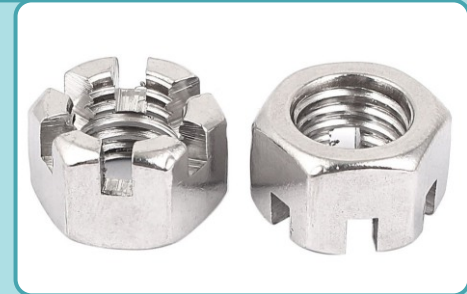

**“IF YOU CAN BELIEVE,
YOU CAN ACHIEVE”**

JBH

J.B.H. AUTOMATICS

31/1 , 1st Floor, Kadipur Industrial Area, Near Jyoti Rubber Factory,
Gurugram, Haryana-121001 INDIA

E-mail: jbhautomatics@gmail.com

KK ENTERPRISES

Plot No. 317, MIE Part-A, Bahadurgarh (Haryana) -124507 INDIA

Tel.: +91 971 7188 985, +91 999 0000 714