

# Digital Thermostat **PAS3**

Model: PAS3



**24 x 48 mm DIN size**



**Depth only 85 mm**

An alarm setter with on/off contact output; most suited for detecting overheat in machines, equipments, etc.

## **Highly compact**

Front panel having a DIN size of 24 x 48 mm, as lightweight as 100 g and besides, depth just 85 mm, featuring a space saving design.

## **A variety of temperature sensors connectable**

Because thermocouples (5 types) and thermistors (0 to 100°C) are connectable, measurement within a wide temperature range from low to high can be covered so as to match your equipment.

## **Measured and Alarm Temperatures Displayable**

Alarm set value and measured temperature value can be checked promptly using the front keys.

## **Alarm point settable in 1°C steps**

Temperature can be set in 1°C steps by key operation from the front.

## **Washable front structure**

The front display and operating section has an IP66 waterproof structure (corresponding to NEMA-4X). This design allows washing from the panel front.

## **2 relay contact outputs available**

This thermostat is capable of issuing 2 relay contact outputs. Therefore, any output of high/low limit pair, 2 upper limits and 2 lower limits can be selected.

24 x 48 mm DIN size



Optimum for detecting overheat in machines, equipments, etc.

# Digital Thermostat

## Specifications

Item	Specification
Input	Number of inputs: 1 Input signal and measurable range: Refer to Table 1. Allowable signal source resistance: Thermocouple input 100 Ω max. Measurement cycle: 2 sec. or less Burnout function: Thermocouple input: UUU display Thermistor input: LLL display (Upscale or downscale at burnout settable) Input impedance: Thermocouple input 1 MΩ or higher Input filter: 0 to 90 sec. (settable in 1 sec. steps) Primary lag filter Input value compensation: Settable within ±10% of measurable range
Indication	Indication means: LCD (without back light) Value/parameter indication: 4 digits of 7 segments each (However, at the 1st digit, only - or 1 is indicated within -999 to 1999.) Contents of indication: Measured value, alarm set value 1, alarm set value 2, various parameters Each indicator of alarms 1 and 2, °C scale
Operation	Number of keys: 3 keys, sheet type keys (embossed) Alarm value setting resolution: 1°C Key lock function: (Change of setting can be inhibited.)
Accuracy	Indication accuracy: Refer to Table 1. (However, error of a temperature sensor is not included.) Reference contact compensation error: ±3°C (at 23°C)
Alarm output	Number of outputs: 1 or 2 (as specified in CODE SYMBOLS) Contact structure: 1a contact Alarm type: Refer to Table 2. Contact capacity: 220 V AC/30 V DC, 2 A (resistance load) 220 AC/30 DC, 1 A (inductive load) Mechanical life of contact: 20 million activations or more (100 activations/min.) Electrical life of contact: 100,000 activations or more (rated load) Output resetting cycle: 2 sec. or less Alarm value settable range: Settable within 0 to 100% of measurable range Hysteresis width settable range: 0 to 110% of measurable range (settable in 1°C steps) Alarm action delay time: Settable within 1 to 120 sec.
Power supply	Power supply voltage: 100 V (-15%) to 240 V (+10%) AC 50/60 Hz (±10%) Power consumption: 3 VA max. (with 100 V AC), 6 VA max. (with 240 V AC)
Operating conditions	Ambient temperature: 0 to 50°C Ambient humidity: 90% RH max. (condensation unallowable)
Body structure	Mounting method: Panel flush mounting External dimensions (H x W x D): 24 x 48 x 85 mm Weight: Approx. 100 g Casing material: Plastic (corresponding to flame resistance grade UL94V-0) Front protective structure: IP66 (corresponding to NEMA-4X) when using Fuji's genuine front waterproof packing part External terminals: Plug-in type (for bar terminals) Finish color: Ivory

## Alarm output hysteresis width

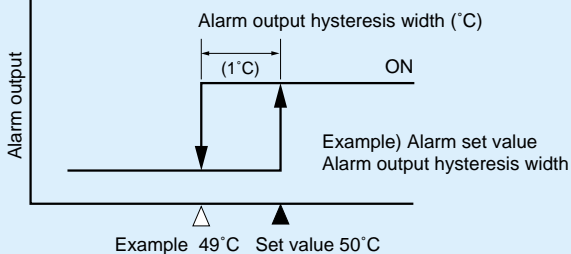

## Input signal, measurable range and indication accuracy (Table 1)

Input signal		Measurable range (°C)	Minimum resolution	Indication accuracy
Thermocouple	J	0 to 800	1°C	±3°C
	K	0 to 1200	1°C	±3°C
	R	0 to 1600	4°C	±4°C
	T	0 to 400	1°C	±3°C
	E	0 to 600	1°C	±3°C
Thermistor	PB-36	0 to 100	1°C	±4°C

Note 1) Correct indication is not ensured within a range from 0 to 500°C for an R type thermocouple.

Note 2) Switching between a thermistor and a thermocouple is not allowed.  
Thermocouple input type can be changed by front key operation.

## Alarm types (Table 2)

Code of PA1, 2	Alarm direction	Set value notation	With holding (Note 2)	Relay action at alarm	Action diagram (Note 1)
0	No alarm	-	-	-	
1	Upper limit	Absolute value	No	Relay excitation	
2	Lower limit	Absolute value	No	Relay excitation	
3	Upper limit	Absolute value	Yes	Relay excitation	
4	Lower limit	Absolute value	Yes	Relay excitation	
5	Upper limit	Absolute value	No	Relay non-excitation	
6	Lower limit	Absolute value	No	Relay non-excitation	
7	Upper limit	Absolute value	Yes	Relay non-excitation	
8	Lower limit	Absolute value	Yes	Relay non-excitation	

(Note 1) How to read action

area: A range in which "ALM1 or ALM2" is indicated on LCD at the front.

area: A range in which alarm relay is excited

△ point: Alarm set value

The horizontal axis represents measured values (PV).

### What is the hold function?

Even if the process value is within the alarm range when turning on power, the alarm does not turn on immediately but only after it leaves and then returns to the alarm range.

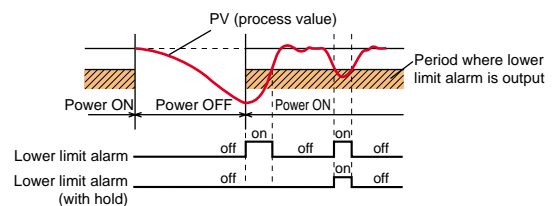

## Model

Input signal	Temperature sensor	Number of alarm	Model
Thermocouple	Option	1	PAS3K1Y1
		2	PAS3K1A1
Thermistor	Provided	1	PAS3H1Y1
		2	PAS3H1A1

## Settings at delivery

Measurable range	K thermocouple input (0 to 1200°C) Thermistor input (0 to 100°C)
Alarm set value	K thermocouple input: For 1-point alarm (upper limit 1200°C) K thermocouple input: For 2-point alarm (upper limit 1200°C, lower limit alarm 0°C) Thermistor input: For 1-point alarm (upper limit 100°C) Thermistor input: For 2-point alarm (upper limit 100°C, lower limit alarm 0°C)
Alarm hysteresis width	1°C
Alarm delay time	0 sec.
Indication	Measured value
Burnout	Upscale at burnout
Input filter	5 sec.
Input value compensation	0%

Note 1) Switching between a thermistor and a thermocouple is not allowed.  
Note 2) Thermocouple input type can be changed by front key operation.

## Scope of delivery

Thermostat unit, panel-mounting adapter,  
front waterproof packing  
Thermistor sensor added for thermistor input

## Attached thermistor sensor

### Attachment for thermistor-input thermostat

Measurable range	0 to 100°C
B constant	3390 K
Nominal resistance value	6 kΩ (0°C)
Lead wire	Heat-resisting vinyl chloride wire
Lead wire length	500 mm
Lead wire heat resisting temperature	-20 to 105°C
Color code	Black
Accuracy	Within ±2°C

### Outline diagram (unit: mm)

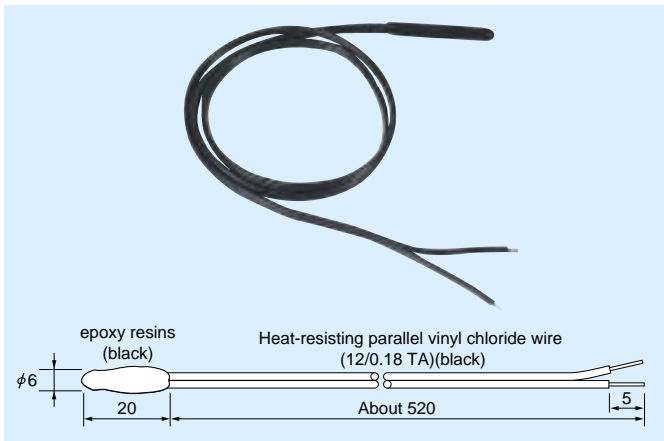

## Connection method



## Outline diagram (unit: mm)

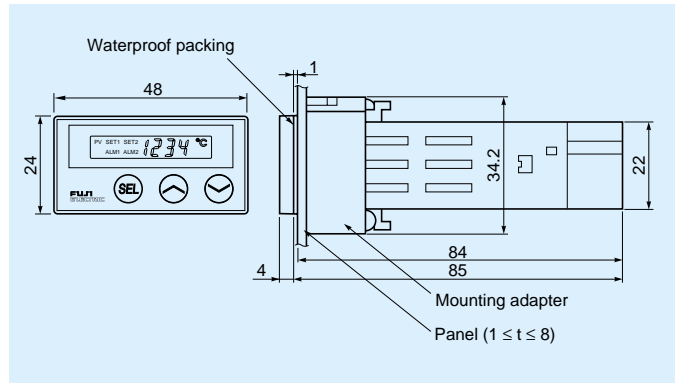

## Panel cutout

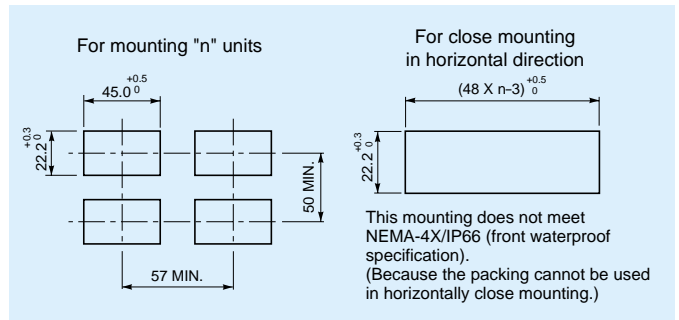

## Connection diagram

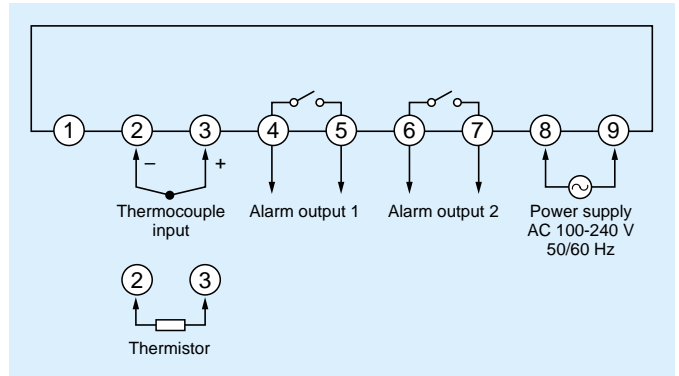

## Usable wiring materials

### Wire

Gauge: AWG28 (0.1 mm<sup>2</sup>) ... AWG16 (1.25 mm<sup>2</sup>) AWG28...AWG16  
Strip-off length: 5 to 6 mm

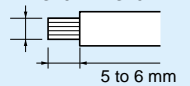

### Bar terminal

Dimension of strip-off conductor section: 2 x 1.5 mm or smaller  
Length of strip-off conductor section: 5 to 6 mm

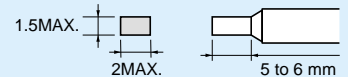

## Related documents

Operation manual: ECNO: 410  
Data sheet: EDS11-141

### **Caution on handling**

- If a radio is brought close to this thermostat, noise may enter. Use a radio away from this thermostat.
- Don't bring a mobile phone within 50 cm of this thermostat. Otherwise, the thermostat may malfunction.

---

### **Fuji Electric Co.,Ltd.**

Head office  
11-2 Osaki 1-chome, Sinagawa-ku, Tokyo,141-0032 Japan  
<http://www.fujielectric.co.jp>

### **Fuji Electric Instruments Co.,Ltd.**

International Sales Dept.  
No.1 , Fuji-machi, Hino-city, Tokyo,191-8502 Japan  
Phone : 81-42-585-6201,6202  
Fax : 81-42-585-6187,6189  
<http://www.fic-net.co.jp>