



EPEL

Catalogue

 | 주 | 에 펠

(주) 에펠

1. 풍부한 기술력이 바탕이 된 기업

도로조명, 주거단지, 공원 등의 아름다운 도시경관조성을 위한 기능적이고 환경 친화적인 공공시설물 제작 및 설치에 기술력과 노하우를 겸비한 기업으로, 다수의 특허와 디자인 등록 및 서울 우수공공디자인, 경기도 공공시설물 우수디자인 등을 보유하고 있습니다.

2. 끊임없이 발전을 도모하는 창의적인 기업

빠르게 변화하는 시대에 한 발 앞서 준비하고 실천하는 기업으로, 주변 환경과 어울리는 색채와 디자인을 최고 품질의 제품으로 구현하기 위하여 창의적이고 적극적인 연구개발에 힘쓰는 성장하는 기업입니다.

3. 스마트가로등 개발의 선두 기업

스마트 시대에 맞춰 스마트시티 도시기반 시설인 스마트가로등을 개발 하였으며, 스마트 서비스에 대한 연구 개발에 전력을 다하여 오늘보다 내일이 더 나은 기업이 되겠습니다.





목차
Contents

1. 가로등주	4
2. 보안등주	15
3. 가로등주 부속자재	25
4. 등기구	32
5. LED 경관조명기구	41
6. 블라드	49
7. 스마트 가로등 및 스마트 폴	51



1 가로등주

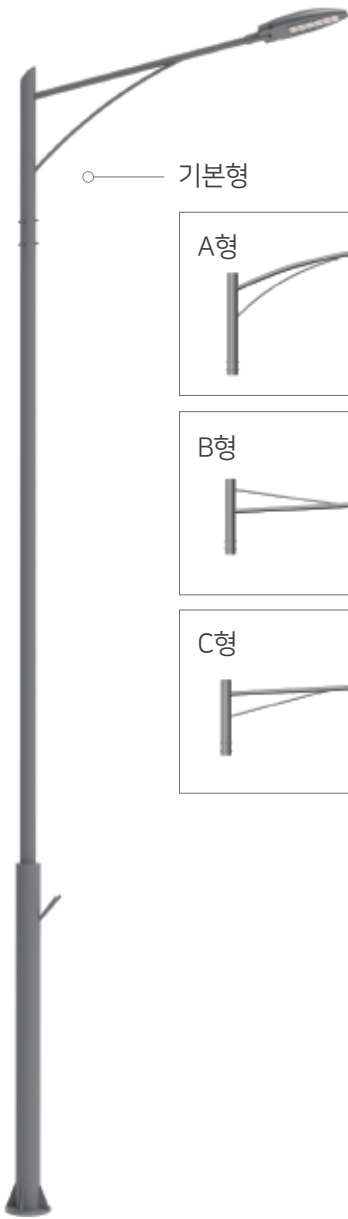

○ 기본형

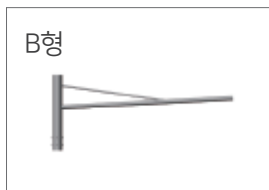
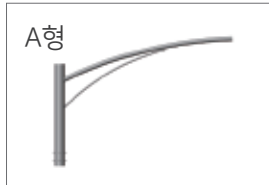

EPSS05

MODEL	MATERIAL	HEIGHT	물품식별번호
EPSS05-081	STEEL	8m	22652537
EPSS05-08(5)1	STEEL	8.5m	22652538
EPSS05-091	STEEL	9m	22541920
EPSS05-101	STEEL	10m	22541921

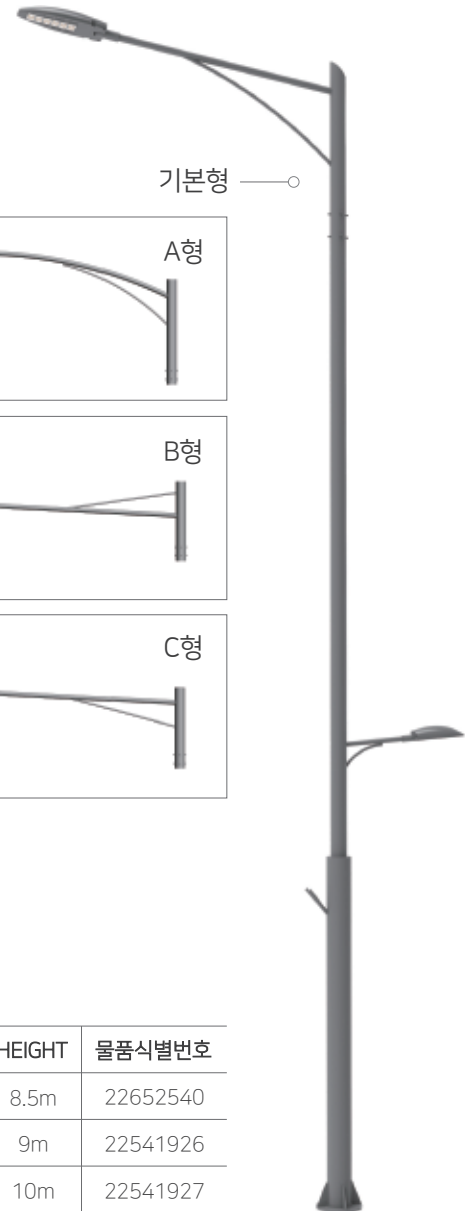

기본형 ○

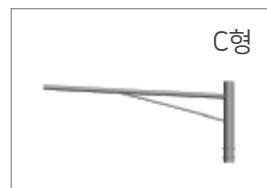
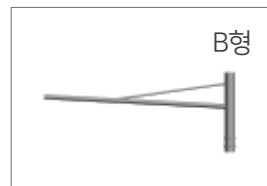

EPSS05-1

MODEL	MATERIAL	HEIGHT	물품식별번호
EPSS05-08(5)1-1	STEEL	8.5m	22652540
EPSS05-091-1	STEEL	9m	22541926
EPSS05-101-1	STEEL	10m	22541927

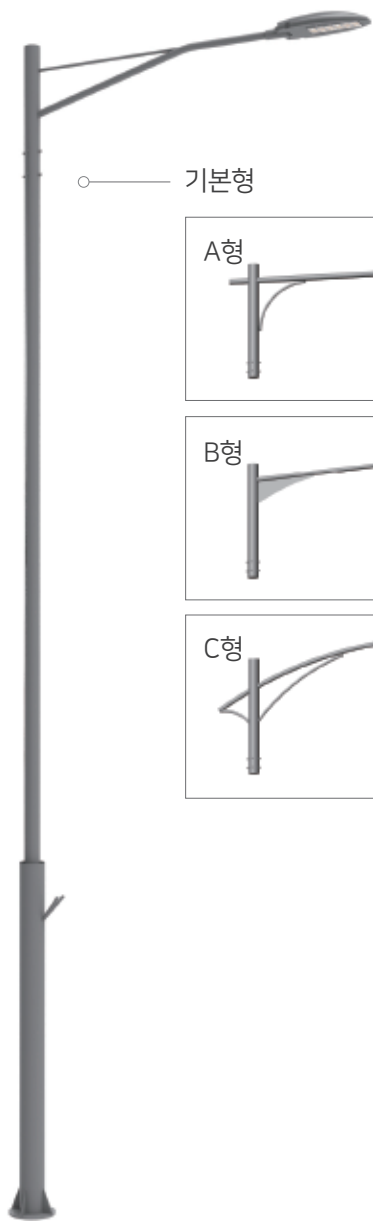

기본형

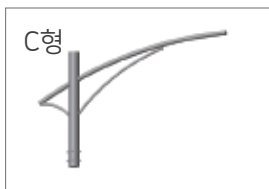

EPSS08

MODEL	MATERIAL	HEIGHT	물품식별번호
EPSS08-08(5)1	STEEL	8.5m	22656467
EPSS08-101	STEEL	10m	22656469



기본형

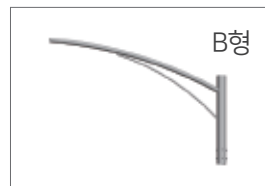
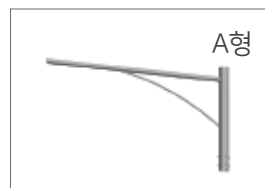

EPSS12

MODEL	MATERIAL	HEIGHT	물품식별번호
EPSS12-081	STEEL	8m	22849756
EPSS12-0851	STEEL	8.5m	22906256
EPSS12-091	STEEL	9m	22849757
EPSS12-101	STEEL	10m	22849758

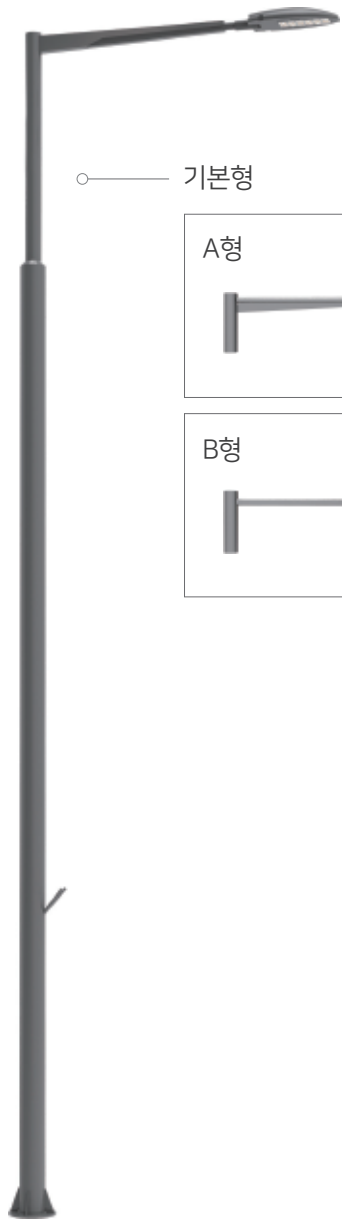

기본형

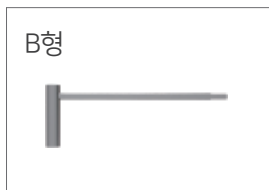

EPSS15

MODEL	MATERIAL	HEIGHT	물품식별번호
EPSS15-081	STEEL	8m	23060419
EPSS15-091	STEEL	9m	23060421
EPSS15-101	STEEL	10m	23060422

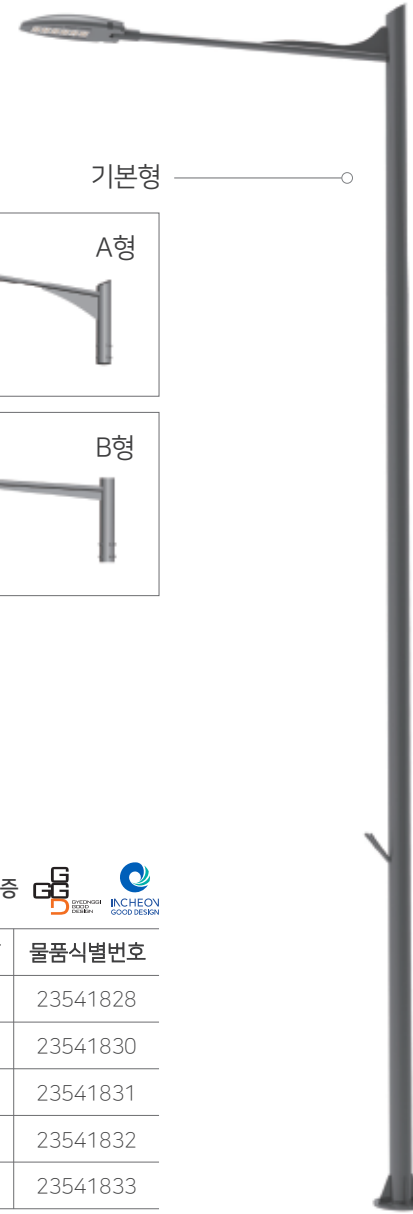

기본형

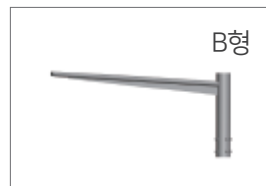
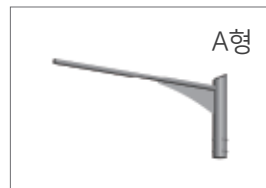

EPSS20

공공디자인인증  

MODEL	MATERIAL	HEIGHT	물품식별번호
EPSS20-081	STEEL	8m	23541828
EPSS20-0851	STEEL	8.5m	23541830
EPSS20-091	STEEL	9m	23541831
EPSS20-101	STEEL	10m	23541832
EPSS20-121	STEEL	12m	23541833



EPSS22

MODEL	MATERIAL	HEIGHT	물품식별번호
EPSS22-081	STEEL	8m	23541807
EPSS22-0851	STEEL	8.5m	23541858
EPSS22-091	STEEL	9m	23541808
EPSS22-101	STEEL	10m	23541859

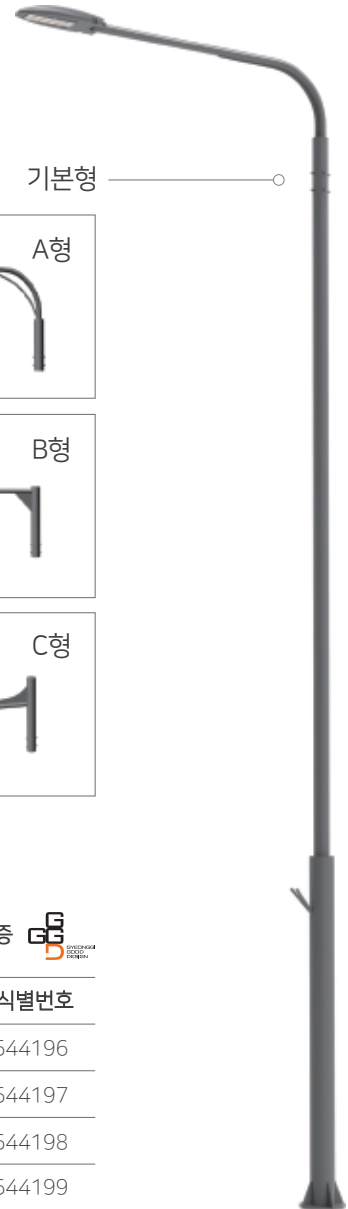

기본형

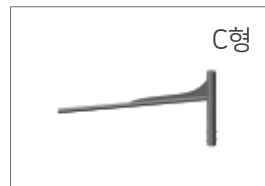

EPSS23

공공디자인인증

MODEL	MATERIAL	HEIGHT	물품식별번호
EPSS23-081	STEEL	8m	23544196
EPSS23-0851	STEEL	8.5m	23544197
EPSS23-091	STEEL	9m	23544198
EPSS23-101	STEEL	10m	23544199

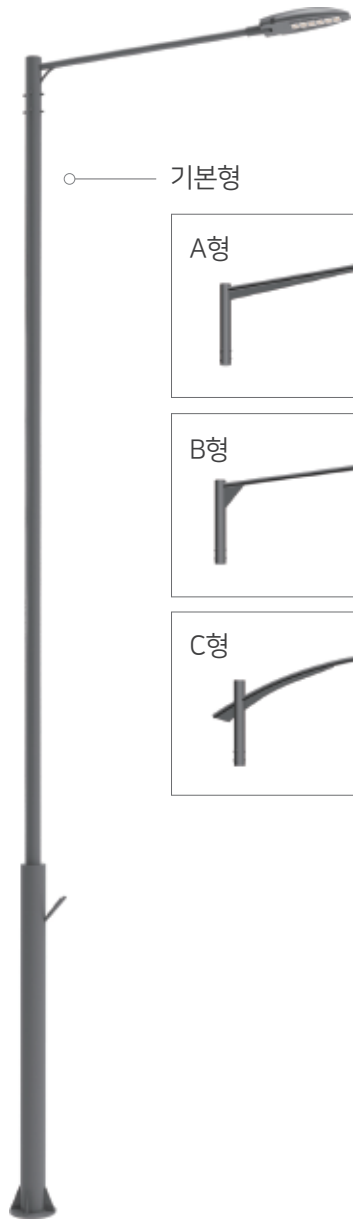

기본형



EPSS24

MODEL	MATERIAL	HEIGHT	물품식별번호
EPSS24-081	STEEL	8m	23544201
EPSS24-0851	STEEL	8.5m	23544202
EPSS24-091	STEEL	9m	23544203
EPSS24-101	STEEL	10m	23544204
EPSS24-121	STEEL	12m	23544205

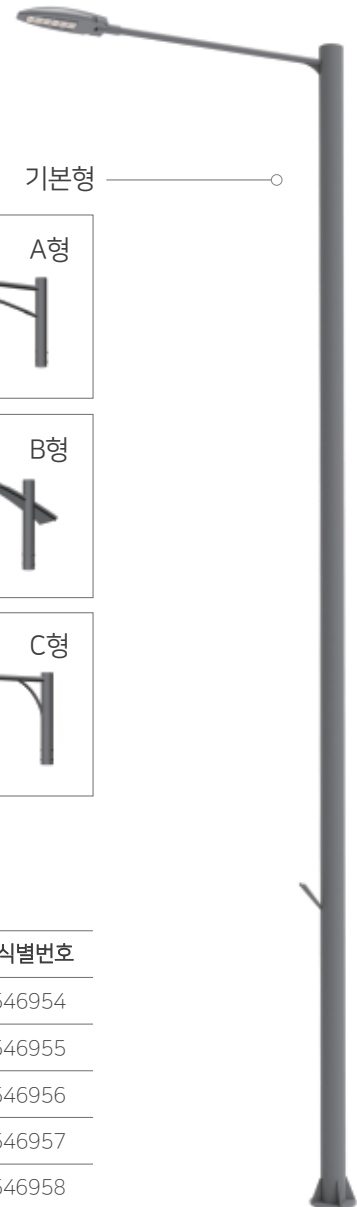

기본형

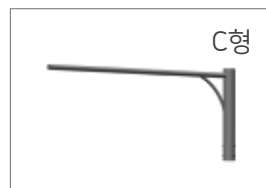
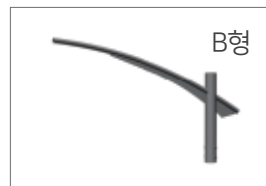
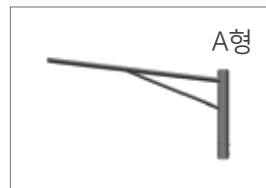

EPSS25

MODEL	MATERIAL	HEIGHT	물품식별번호
EPSS25-081	STEEL	8m	23546954
EPSS25-0851	STEEL	8.5m	23546955
EPSS25-091	STEEL	9m	23546956
EPSS25-101	STEEL	10m	23546957
EPSS25-121	STEEL	12m	23546958



EPSS(P)

MODEL	MATERIAL	HEIGHT	물품식별번호
EPSS(P)-08-1	STEEL	6.5m	22652955
EPSS(P)-10-1	STEEL	8.5m	22652957

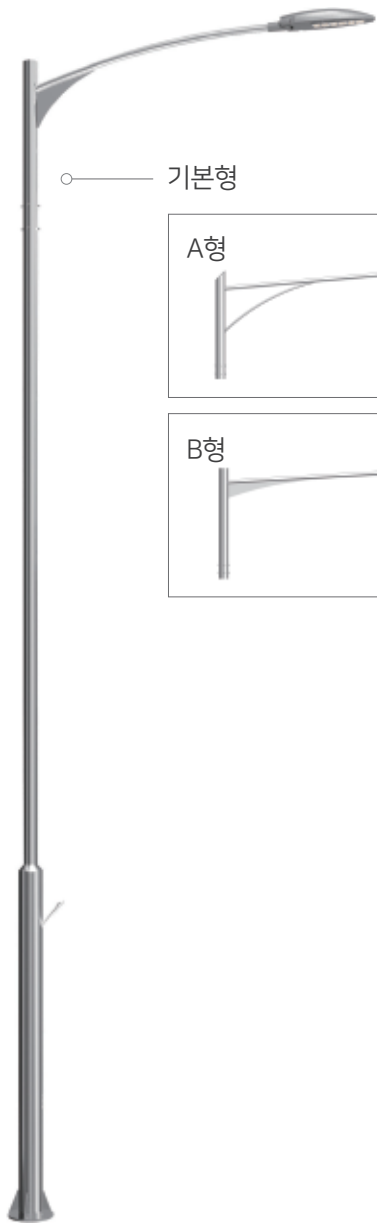

기본형

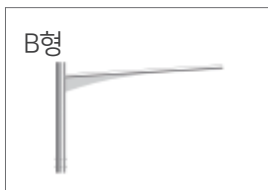
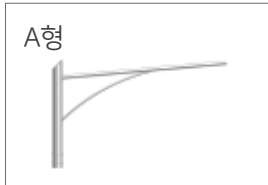

EPS05

MODEL	MATERIAL	HEIGHT	물품식별번호
EPS05-081	STS	8m	22652645
EPS05-101	STS	10m	22652647

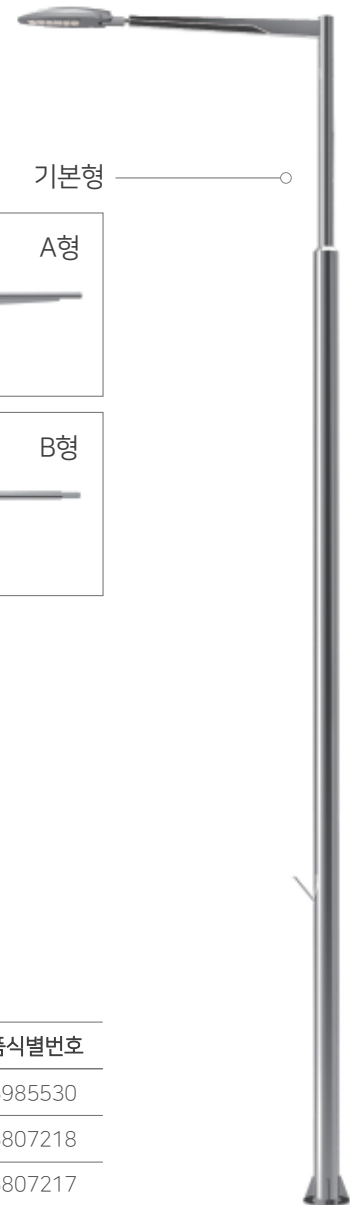

기본형

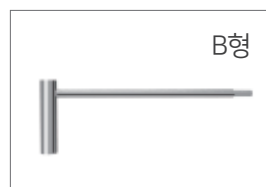

EPS06,07

MODEL	MATERIAL	HEIGHT	물품식별번호
EPS07-081	STS	8m	23985530
EPS06-0851	STS	8.5m	23807218
EPS07-101	STS	10m	23807217



EPAS01

MODEL	MATERIAL	HEIGHT	물품식별번호
EPAS01-081	AL	8m	22657351
EPAS01-08(5)1	AL	8.5m	22657352
EPAS01-101	AL	10m	22657355
EPAS01-121	AL	12m	22657358

EPAS01-1

MODEL	MATERIAL	HEIGHT	물품식별번호
EPAS01-101-1	AL	10m	22946248

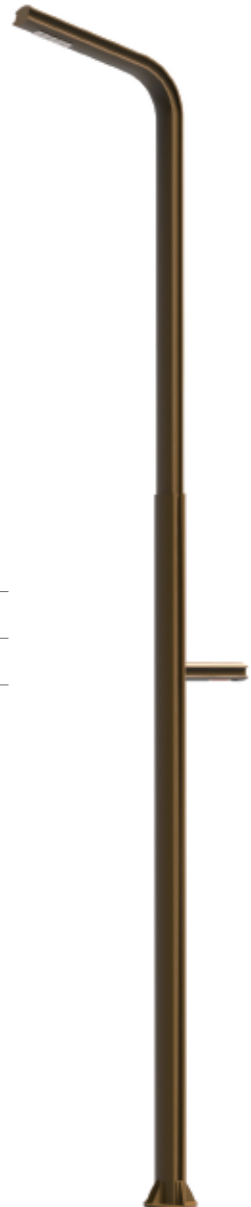



EPAS07

MODEL	MATERIAL	HEIGHT	물품식별번호
EPAS07-081	AL	8m	23063282
EPAS07-0851	AL	8.5m	23063283
EPAS07-101	AL	10m	23063285

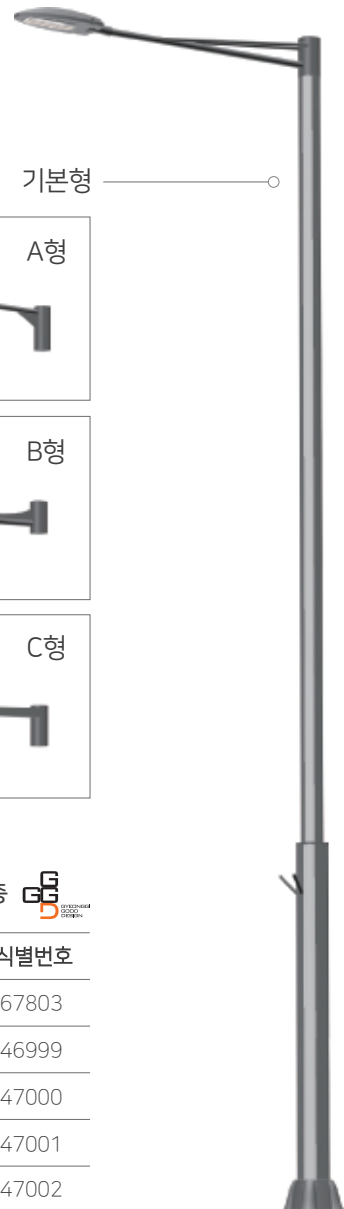

기본형

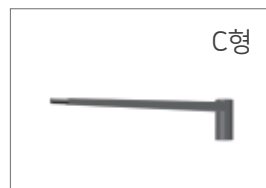
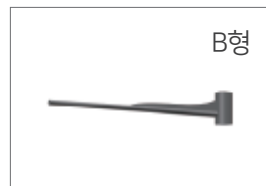
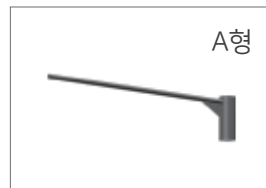

EPAS10

공공디자인인증

MODEL	MATERIAL	HEIGHT	물품식별번호
EPAS10-071	AL	7m	23667803
EPAS10-081	AL	8m	23546999
EPAS10-0851	AL	8.5m	23547000
EPAS10-091	AL	9m	23547001
EPAS10-101	AL	10m	23547002

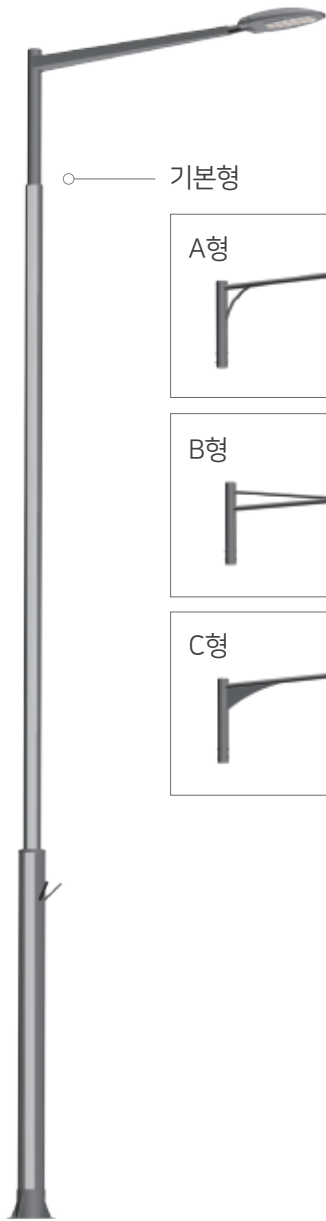

기본형

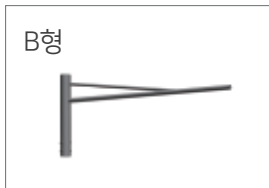
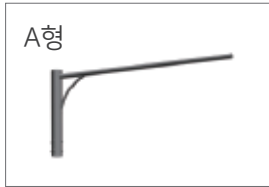

EPAS11

공공디자인인증 

MODEL	MATERIAL	HEIGHT	물품식별번호
EPAS11-081	AL	8m	23547004
EPAS11-0851	AL	8.5m	23547005
EPAS11-091	AL	9m	23547006
EPAS11-101	AL	10m	23547007

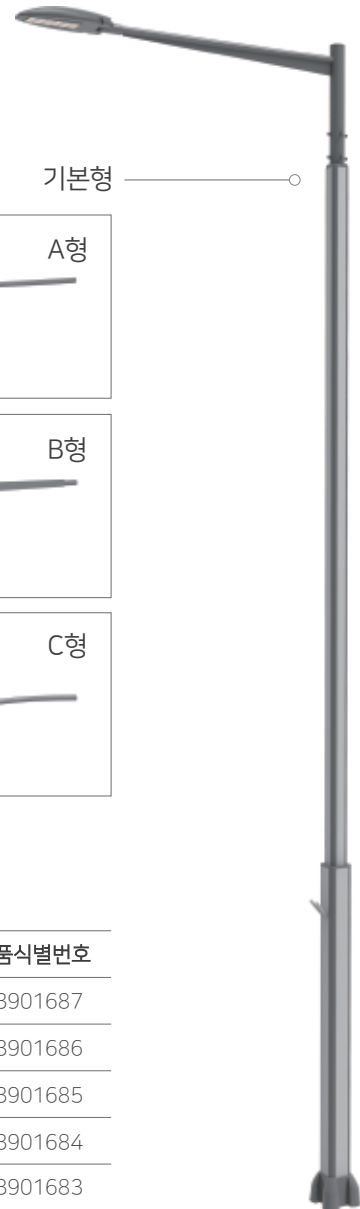

기본형

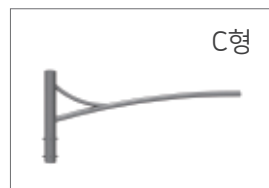
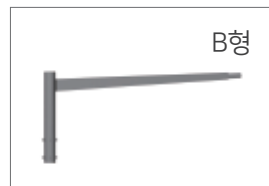
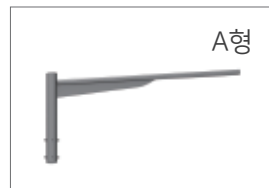

EPAS12

MODEL	MATERIAL	HEIGHT	물품식별번호
EPAS12-071	AL	7m	23901687
EPAS12-081	AL	8m	23901686
EPAS12-0851	AL	8.5m	23901685
EPAS12-091	AL	9m	23901684
EPAS12-101	AL	10m	23901683



2 보안등주



기본형

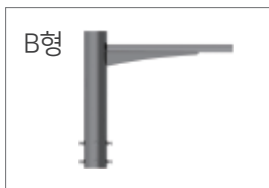

EPSP04

공공디자인인증  GDS
GOOD DESIGN

MODEL	MATERIAL	HEIGHT	물품식별번호
EPSP04-041	STEEL	4m	23901681
EPSP04-051	STEEL	5m	23901680

기본형



EPSP06

MODEL	MATERIAL	HEIGHT	물품식별번호
EPSP06-041	STEEL	4m	22469285
EPSP06-051-1	STEEL	5m	22652643





EPSP07

MODEL	MATERIAL	HEIGHT	물품식별번호
EPSP07-051	STEEL	5m	23067717



기본형

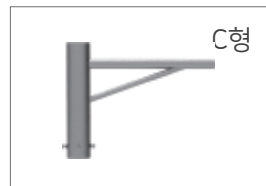
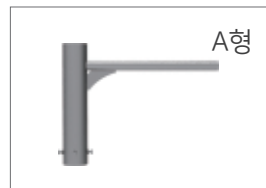

EPSP08

MODEL	MATERIAL	HEIGHT	물품식별번호
EPSS08-051	STEEL	5m	23071653

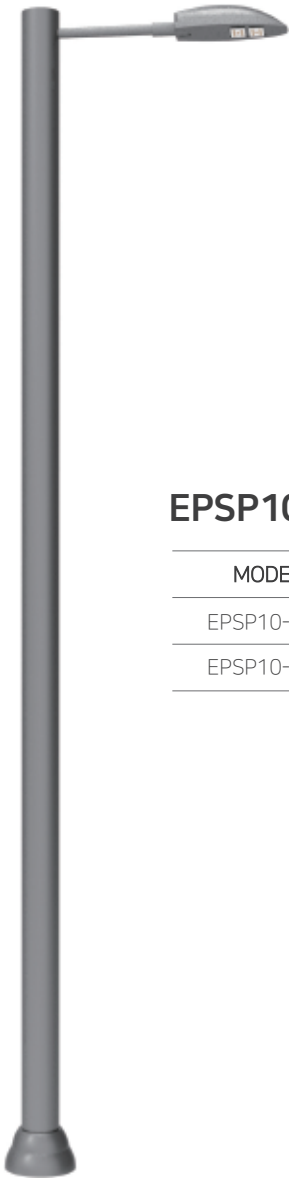

EPSP10

MODEL	MATERIAL	HEIGHT	물품식별번호
EPSP10-051	STEEL	5m	23320373
EPSP10-061	STEEL	6m	23681504

EPSP10-1

MODEL	MATERIAL	HEIGHT	물품식별번호
EPSP10-0451	STEEL	4.5m	23316568





EPSP10-2

MODEL	MATERIAL	HEIGHT	물품식별번호
EPSP10-0452	STEEL	4.5m	23316569



EPSP11

MODEL	MATERIAL	HEIGHT	물품식별번호
EPSP11-041	STEEL	4m	23543765
EPSP11-051	STEEL	5m	23440183

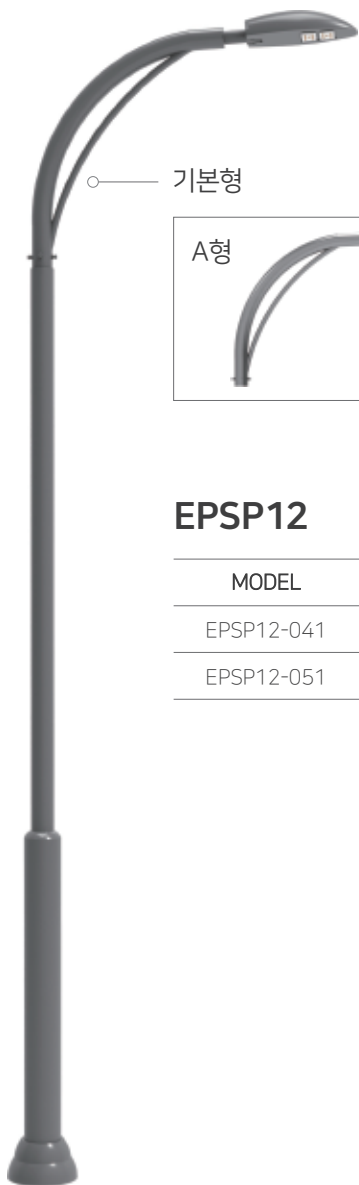

EPSP12

MODEL	MATERIAL	HEIGHT	물품식별번호
EPSP12-041	STEEL	4m	23901679
EPSP12-051	STEEL	5m	23901678

EPSP(P)

MODEL	MATERIAL	HEIGHT	물품식별번호
EPSP(P)-045	STEEL	4.5m	22849751



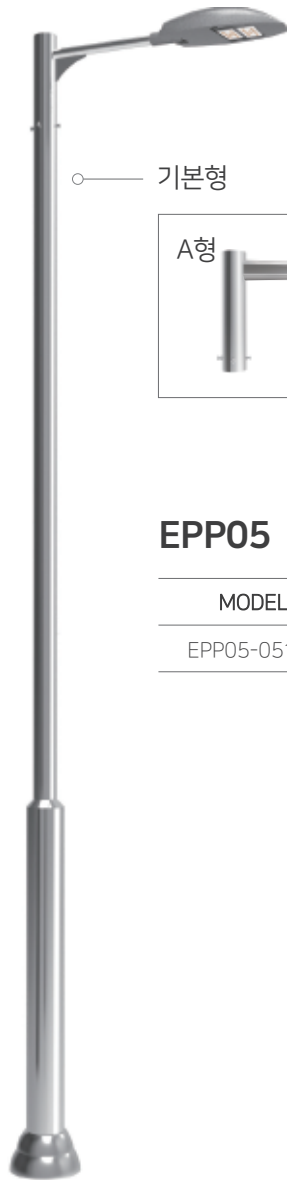

○ 기본형



EPP05

MODEL	MATERIAL	HEIGHT	물품식별번호
EPP05-051-1	STS	5m	22652649

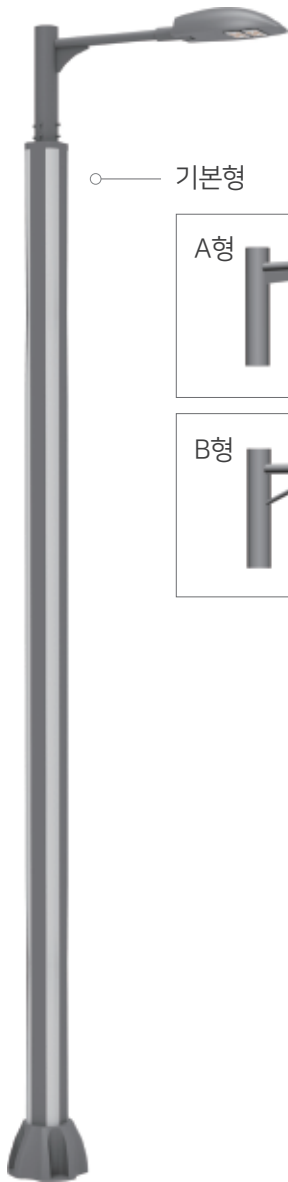

○ 기본형

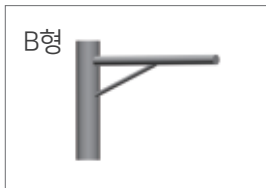

EPAP

MODEL	MATERIAL	HEIGHT	물품식별번호
EPAP-041-1	AL	4m	22906275
EPAP-051-1	AL	5m	22652549
EPAP-061-1	AL	6m	23667804

EPAP(P)

공공디자인인증 

MODEL	MATERIAL	HEIGHT	물품식별번호
EPAP(P)-05-1	AL	4.5m	22652550



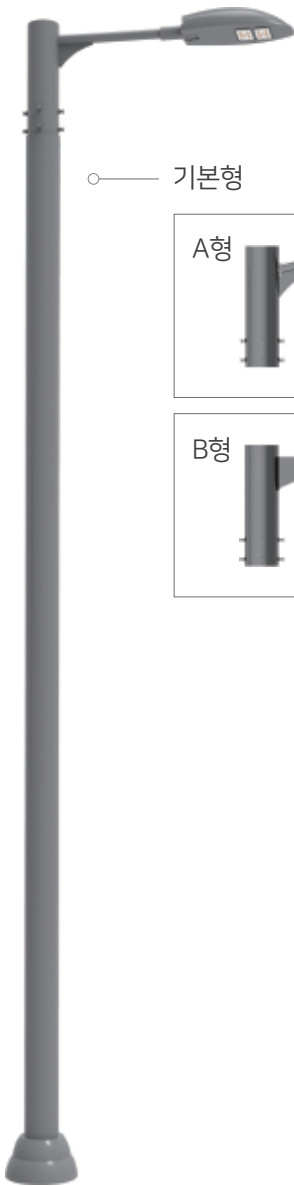

○ 기본형

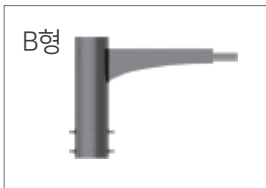

EPAP09

공공디자인인증



MODEL	MATERIAL	HEIGHT	물품식별번호
EPAP09-051	AL	5m	23901688

EPAP08

공공디자인인증



MODEL	MATERIAL	HEIGHT	물품식별번호
EPAP08-045	AL	4.5m	23901682



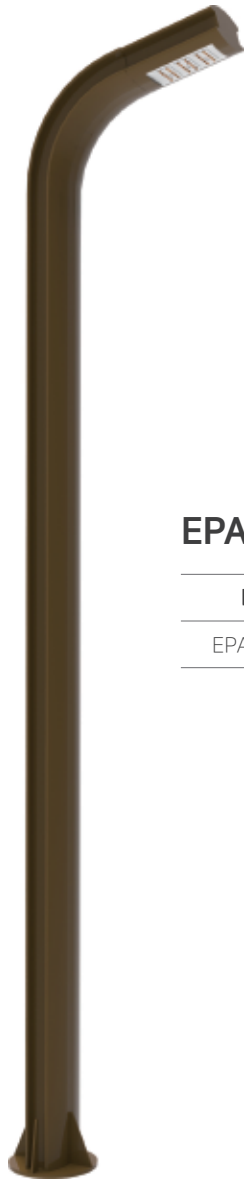

EPAP07

공공디자인인증 

MODEL	MATERIAL	HEIGHT	물품식별번호
EPAP07-451	AL	4.5m	22703305



3 가로등주 부속자재



EPAC-06A 스테인리스 암

MODEL	LENGTH	물품식별번호
EPAC-06A	1.5~2.8m	22470617

EPAC-06B 스테인리스 암

MODEL	LENGTH	물품식별번호
EPAC-06B	1.5~2.8m	22470618



EPAC-20A 스테인리스 암

MODEL	LENGTH	물품식별번호
EPAC-20A	1.5~2.8m	22664641



EPAC-16A 스테인리스 암

MODEL	LENGTH	물품식별번호
EPAC-16A	0.5m	22470629

EPAC-16B 스테인리스 암

MODEL	LENGTH	물품식별번호
EPAC-16B	0.5m	22470630



EPAC-27A 1등용암

MODEL	LENGTH	물품식별번호
EPAC-27A	0.5m	23338751

EPAC-27B 2등용암

MODEL	LENGTH	물품식별번호
EPAC-27B	1m	23338752

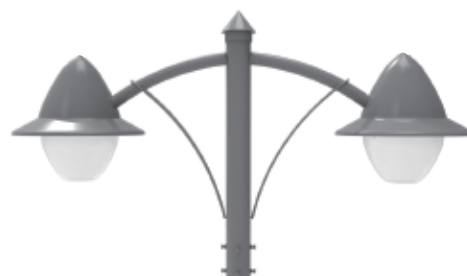



EPAC-13 보행등암

MODEL	LENGTH	물품식별번호
EPAC-13	0.6m	22470625

EPAC-19 보행등암

MODEL	LENGTH	물품식별번호
EPAC-19	0.3~0.5m	22704080

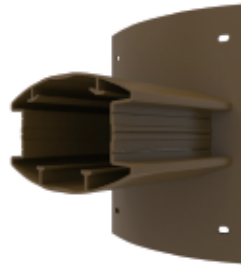

EPAC-29 보행등암

MODEL	LENGTH	물품식별번호
EPAC-29	0.6m	23547009

EPAC-26 한전주암

MODEL	LENGTH	물품식별번호
EPAC-26	1.0m	22965098





EPAC-21A 스테인리스 암

MODEL	LENGTH	물품식별번호
EPAC-21A	1.5~2.8M	22908968

EPAC-21B 스테인리스 암

MODEL	LENGTH	물품식별번호
EPAC-21B	1.5~2.8m	22908967



EPAC-26A 통합폴암

MODEL	LENGTH	물품식별번호
EPAC-26A	2m	23338749



EPAC-26B 통합폴암

MODEL	LENGTH	물품식별번호
EPAC-26B	2m	23338750





EPAC-11 단방향 배너걸이

MODEL	LENGTH	물품식별번호
EPAC-11	0.8m	22469025

EPAC-12 양방향 배너걸이

MODEL	LENGTH	물품식별번호
EPAC-12	0.8m	22469024



EPAC-22 베이스커버

MODEL	LENGTH	물품식별번호
EPAC-22	245 × 240 × 410mm	22965094

EPAC-23 베이스커버

MODEL	LENGTH	물품식별번호
EPAC-23	240 × 410 × 240mm	22965095

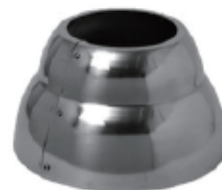

EPAC(P)-23 베이스커버 (공원등용)

MODEL	SIZE	물품식별번호
EPAC(P)-23	175 × 310 × 175mm	23913001



EPAC-24 베이스커버

MODEL	SIZE	물품식별번호
EPAC-24	480 × 260mm	22965096

EPAC-25 베이스커버

MODEL	SIZE	물품식별번호
EPAC-25	260 × 420 × 270mm	22965097

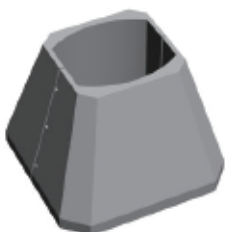
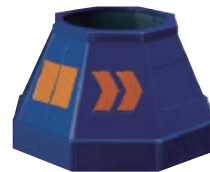

EPAC-28 베이스커버

MODEL	SIZE	물품식별번호
EPAC-28	260 × 420 × 300mm	23430254



4 등기구



LED 가로등기구

100W / 125W / 150W

50,000시간 이상의 장수명
 효율이 높은 컨버터를 적용하여 높은 광효율을 구현
 방열, 방수, 배광 일체형 제품
 LED 표준모듈 탑재
 고효율에너지기자재 인증 취득



물품식별번호	23221750	23221751	23221752
모델명	EPL-ST-S100	EPL-ST-S125	EPL-ST-S150
환경표지인증	제 18677 호	제 18677 호	제 18677 호
고효율기자재	제 15286 호	제 15287 호	제 15288 호
전자파적합등록	R-REM-epl- EPL-ST-S100H	R-REM-epl- EPL-ST-S125H	R-REM-epl- EPL-ST-S150H

물품식별번호	23221750	23221751	23221752
모델명	EPL-ST-S100	EPL-ST-S125	EPL-ST-S150
소비전력	100W	125W	150W
LED	Lumileds	Lumileds	Lumileds
중량	6kg	6.3kg	6.7kg
방수등급	IP66	IP66	IP66
색온도	5,000K	5,000K	5,000K
연색성(Ra)	>75	>75	>75
정격광속	11,500 lm	14,375 lm	17,250 lm
광효율	115 lm/W 이상	115 lm/W 이상	115 lm/W 이상
배광곡선			

Out line dimation

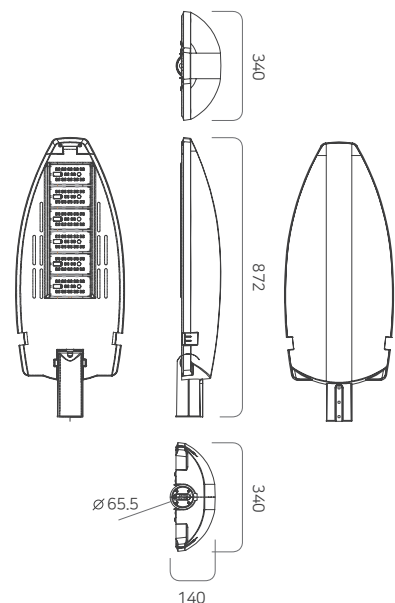



LED 스마트 가로등기구

100W / 125W / 150W

- 50,000시간 이상의 장수명
- 효율이 높은 컨버터를 적용하여 높은 광효율을 구현
- 방열, 방수, 배광 일체형 제품
- LED 표준모듈 탑재
- 고효율에너지기자재 인증 취득



물품식별번호	23818399	23818390	23818391
모델명	EPL-ST-S100D	EPL-ST-S125D	EPL-ST-S150D
환경표지인증	제 18677 호	제 18677 호	제 18677 호
고효율기자재	제 45385 호	제 45386 호	제 45327 호

물품식별번호	23818399	23818390	23818391	Out line dimation
모델명	EPL-ST-S100D	EPL-ST-S125D	EPL-ST-S150D	
소비전력	100W	125W	150W	
LED	Lumileds	Lumileds	Lumileds	
중량	6kg	6.3kg	6.7kg	
방수등급	IP66	IP66	IP66	
색온도	5,000K	5,000K	5,000K	
연색성(Ra)	>75	>75	>75	
정격광속	11,500 lm	14,375 lm	17,250 lm	
광효율	115 lm/W 이상	115 lm/W 이상	115 lm/W 이상	
배광곡선				



LED 보안등기구

40W / 50W / 60W / 75W

- 50,000시간 이상의 장수명
- 효율이 높은 컨버터를 적용하여 높은 광효율을 구현
- 방열, 방수, 배광 일체형 제품
- LED 표준모듈 탑재
- 고효율에너지기자재 인증 취득

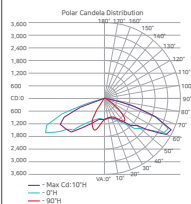
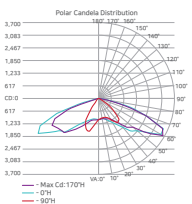
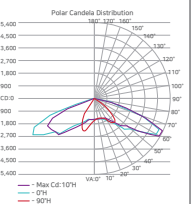
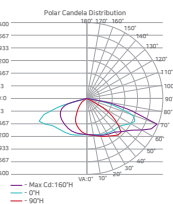

물품식별번호	23219874	23219875	23585123	23888878
모델명	EPL-SC-S40L	EPL-SC-S50	EPL-SC-S60	EPL-SC-S75
환경표지인증	제 18677 호	제 18677 호		
고효율기자재	제 14961 호	제 14983 호	제 20539 호	제 44730 호
전자파적합등록	R-REM-epl-EPL-SC-S40L	R-REM-epl-EPL-SC-S50H	R-REM-epl-EPL-SC-S60	R-R-epl-EPL-SC-S75

물품식별번호	23219874	23219875	23585123	23888878
모델명	EPL-SC-S40L	EPL-SC-S50	EPL-SC-S60	EPL-SC-S75
소비전력	40W	50W	60W	75W
LED	Lumileds	Lumileds	Lumileds	Lumileds
중량	3.4kg	3.4kg	3.4kg	3.4kg
방수등급	IP66	IP66	IP66	IP66
색온도	5,000K	5,000K	5,000K	5,000K
연색성(Ra)	>75	>75	>75	>75
정격광속	4,600 lm	5,750 lm	6,900 lm	8,625 lm
광효율	115 lm/W 이상	115 lm/W 이상	115 lm/W 이상	115 lm/W 이상
배광곡선				

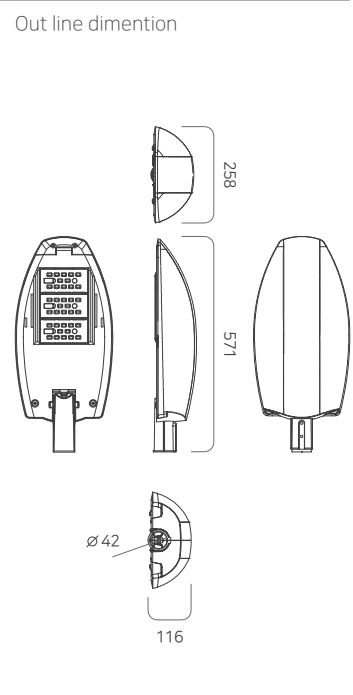



LED 보안등기구

70W

50,000시간 이상의 장수명
 효율이 높은 컨버터를 적용하여 높은 광효율을 구현
 방열, 방수, 배광 일체형 제품
 LED 표준모듈 탑재
 고효율에너지기자재 인증 취득



물품식별번호	23221740
모델명	EPL-LD70
 고효율기자재	제 13325 호
 전자파적합등록	R-R-epl-EPL-SC-S70

물품식별번호	23221740
모델명	EPL-LD70
소비전력	70W
LED	Lumileds
중량	5kg
방수등급	IP65
색온도	5,000K
연색성(Ra)	>75
정격광속	8,050 lm
광효율	115 lm/W 이상
배광곡선	

Out line dimation

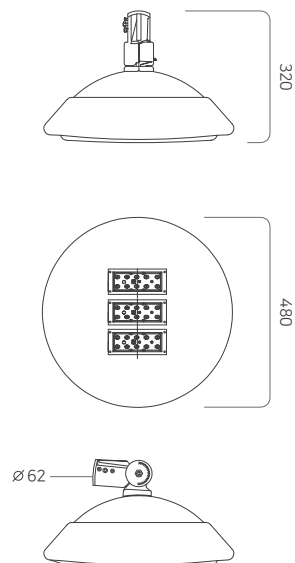



LED 보안등기구

LED 70W

50,000시간 이상의 장수명
 효율이 높은 컨버터를 적용하여 높은 광효율을 구현
 방열, 방수, 배광 일체형 제품
 LED 표준모듈 탑재
 고효율에너지기자재 인증 취득

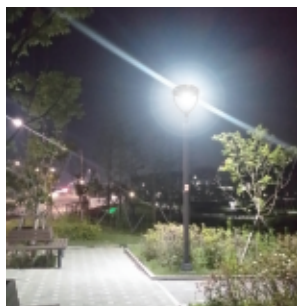

물품식별번호	23888879
모델명	EPL-SC-S70
 고효율기자재	제 45384 호
 전자파적합등록	R-R-epI-EPL-SC-S70

물품식별번호	23888879
모델명	EPL-SC-S70
소비전력	70W
LED	Lumileds
중량	8kg
방수등급	IP65
색온도	5,000K
연색성(Ra)	>75
정격광속	8,050 lm
광효율	115 lm/W 이상
배광곡선	

Out line dimation

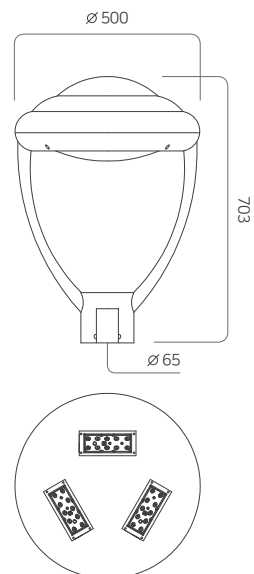

LED 터널용등기구

LED 50W

50,000시간 이상의 장수명
 효율이 높은 컨버터를 적용하여 높은 광효율을 구현
 집광렌즈를 이용한 특허 설계
 고효율에너지기자재 인증 취득



물품식별번호	23340963	23340962
모델명	EPL-TL50(H)	EPL-TL50
고효율기자재	제 20529 호	제 20541 호
전자파적합등록	R-REM-ep-EPL-TL50H	R-REM-ep-EPL-TL50

물품식별번호	23340963
모델명	EPL-TL50(H)
소비전력	50W
LED	Lumileds
방수등급	IP66
색온도	5,000K
연색성(Ra)	>75
정격광속	5,750 lm
광효율	115lm/W이상

배광곡선

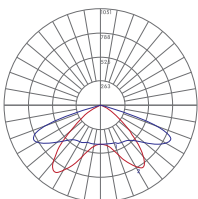

Out line dimention

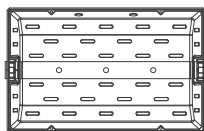
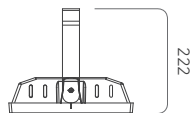
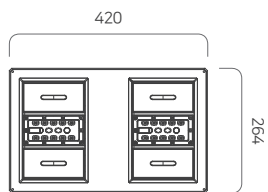

물품식별번호	23340962
모델명	EPL-TL50
소비전력	50W
LED	Lumileds
방수등급	IP66
색온도	5,000K
연색성(Ra)	>75
정격광속	5,750 lm
광효율	115lm/W이상

배광곡선

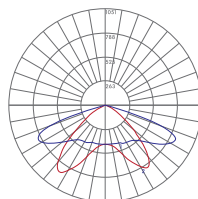

Out line dimention

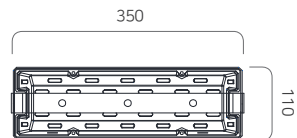
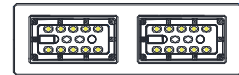

LED 터널용등기구
100W



물품식별번호	23428074
모델명	EPL-TL100H
☀️ 고효율기자재	제 24468 호
🔌 전자파적합등록	R-REM-epI-EPL-TL100H



LED 투광등기구
LED 90W / LED 120W

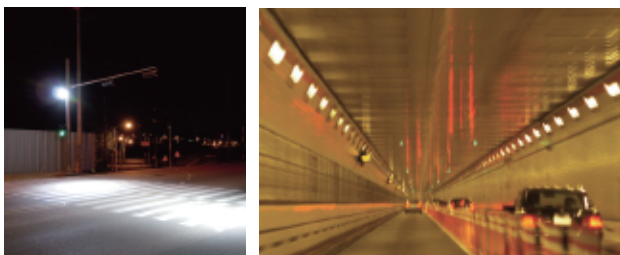

물품식별번호	23499201	23499202
모델명	EPL-FL90	EPL-FL120
☀️ 고효율기자재	제 29235 호	제 29236 호
🔌 전자파적합등록	R-R-epI-EPL-FL90	R-R-epI-EPL-FL120

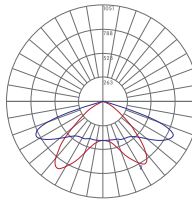
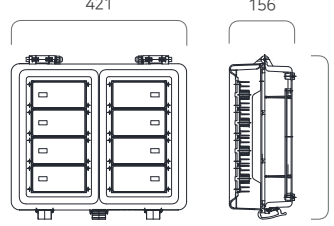
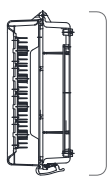
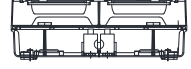

50,000시간 이상의 장수명
360도 회전 및 각도 조절 가능
집광 LENS 적용으로 특정부분(횡단보도 등)을 집중조명에 적합
고효율에너지기자재 인증 취득

물품식별번호	23428074	Out line dimention	
모델명	EPL-TL100H		
소비전력	100W		
LED	Lumileds		
방수등급	IP66		
색온도	5,000K		
연색성(Ra)	>75		
정격광속	11,500 lm		
광효율	115 lm/W 이상		
배광곡선			
			
			

물품식별번호	23499201	물품식별번호	23499202
모델명	EPL-FL90	모델명	EPL-FL120
소비전력	90W	소비전력	120W
LED	삼성 LED	LED	삼성 LED
방수등급	IP66	방수등급	IP66
색온도	5,000K	색온도	5,000K
연색성(Ra)	>75	연색성(Ra)	>75
정격광속	10,350 lm	정격광속	13,800 lm
광효율	115 lm/W 이상	광효율	115 lm/W 이상
배광곡선		배광곡선	

Out line dimention

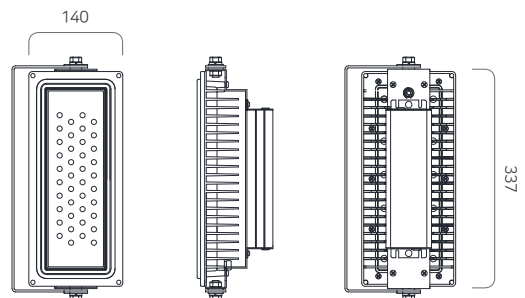

EPBL-E 보안등기구

MODEL	LAMP	물품식별번호
EPBL-E	400W이하	23337533



EPBL-A 보안등기구

MODEL	LAMP	물품식별번호
EPBL-A	70~175W	22379545

EPBL-D 보안등기구

MODEL	LAMP	물품식별번호
EPBL-D	400W이하	22758481





5 LED 경관조명기구



EPB-A

MODEL	LAMP	HEIGHT	물품식별번호
EPB-A	12W이하	1m	22475529



EPB-B

MODEL	LAMP	HEIGHT	물품식별번호
EPB-B	12W이하	1m	22475530



EPL-BL12A 야영장 블라드등

MODEL	LAMP	HEIGHT	물품식별번호
EPL-BL12A	10W이하	1m이하	23659725



EPL-BL12B 야영장 블라드등

MODEL	LAMP	HEIGHT	물품식별번호
EPL-BL12B	10W이하	1m이하	23659726



EPL-BO-001J

MODEL	LAMP	HEIGHT	물품식별번호
EPL-BO-001J	6W	715mm	23835432



EPL-BO-002J

MODEL	LAMP	HEIGHT	물품식별번호
EPL-BO-002J	8+7W	877mm	23837839



EPL-BO-003J

MODEL	LAMP	HEIGHT	물품식별번호
EPL-BO-003J	8W	702mm	23835433



EPL-SLP

MODEL	LAMP	물품식별번호
EPL-SLP100D	100W	23824516
EPL-SLP125D	125W	23824517
EPL-SLP150D	150W	23824518
EPL-SLP40P	40W	23824519
EPL-SLP50P	50W	23824520
EPL-SLP60P	60W	23824521



EPL-LP-50W

MODEL	LAMP	HEIGHT	물품식별번호
EPL-LP-50W	50W	3.99M	23835440



EPL-LP50A

MODEL	LAMP	HEIGHT	물품식별번호
EPL-LP50A	50W	5m	23659719



EPL-LP50B

MODEL	LAMP	HEIGHT	물품식별번호
EPL-LP50B	50W	4.1m	23659720



EPL-LP50C

MODEL	LAMP	HEIGHT	물품식별번호
EPL-LP50C	50W	3.9m	23664224



EPL-WM

MODEL	LAMP	HEIGHT	물품식별번호
EPL-WM80	80W	3.9m	23587712
EPL-WM100	100W	3.9m	23587713



EPB-J

MODEL	LAMP	SIZE	물품식별번호
EPB-J	24W	1.2m	23337004



EPB-K

MODEL	LAMP	SIZE	물품식별번호
EPB-K	30W	2.4m	23337005



EPL-LL-007T-F

MODEL	LAMP	SIZE	물품식별번호
EPL-LL-007T-F	10W	1m	23835429



EPL-LL

MODEL	LAMP	SIZE	물품식별번호
EPL-LL-001D	2.9W	0.2m	23835423
EPL-LL-002D	7.2W	0.5m	23835424
EPL-LL-003D	14.4W	1m	23835425
EPL-LL-004D	4.3W	0.26m	23835426
EPL-LL-005D	8.6W	0.51m	23835427
EPL-LL-006D	17.3W	1m	23835428



EPL-FL-001T-W

MODEL	LAMP	SIZE	물품식별번호
EPL-FL-001T-W	200W	330 × 430 × 360mm	23835437



EPL-FL-002T-F

MODEL	LAMP	SIZE	물품식별번호
EPL-FL-002T-F	380W	362 × 430 × 500mm	23835439



EPL-BE-001J

MODEL	LAMP	SIZE	물품식별번호
EPL-BE-001J	18W	300 × 300 × 250mm	23835430



EPL-BE-002J

MODEL	LAMP	SIZE	물품식별번호
EPL-BE-002J	8W	270 × 270 × 370mm	23835431

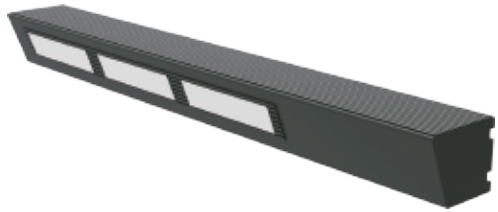

EPL-IL31A

낮은도로조명

MODEL	LAMP	SIZE	물품식별번호
EPL-IL31A	31W	0.78m	23607193

EPL-IL31A 설치사진



EPL-FW06A

MODEL	LAMP	SIZE	물품식별번호
EPL-FW06A	6W	0.23m	23660406

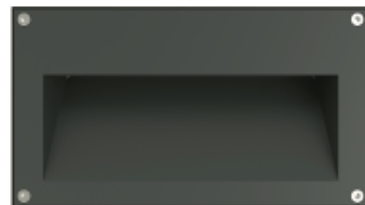

EPL-LO-001J

MODEL	LAMP	SIZE	물품식별번호
EPL-LO-001J	6W	226 × 127 × 70 mm	23835434



6 블라드



EPBL-A04 고인장실리콘

MODEL	SIZE	물품식별번호
EPBL-A04	140 × 70 × 800mm	22362993



EPBL-A05 우레탄

MODEL	SIZE	물품식별번호
EPBL-A05	Ø150 × 800mm	22617796



EPBL-A06 우레탄

MODEL	SIZE	물품식별번호
EPBL-A06	Ø120 × 800mm	23882041



7 스마트 가로등 및 스마트 폴

사물 및 관제서버 간

다양한 무선통신 네트워크 기술 적용

Wireless Communication Network Design & Optimization

RF LoRa WiFi Bluetooth NB-IoT LTE

스마트 가로등

- Pole-to-Pole
- Pole-to-Gateway
- Gateway-to-Server
- Server-to-Gateway
- Gateway-to-Pole
- Pole-to-Server
- Server-to-Pole

스마트 폴

- Pole-to-Smart Phone
- Pole-to-Mobility
- Pole-to-Vehicle
- Server-to-Server
- Pole-to-Pole

시계열 빅데이터 분석 Time-series Big Data Analysis

- 교통량분석기반 도로유형, 구간별 Lighting Zone 설정
- Lighting Zone별 다이نام릭 디밍 제어 설정
- 고장분석 및 에너지 사용 패턴 분석
- 도시시설물에 대한 시민 사용 패턴 분석
- 도시 대기환경 정보 분석

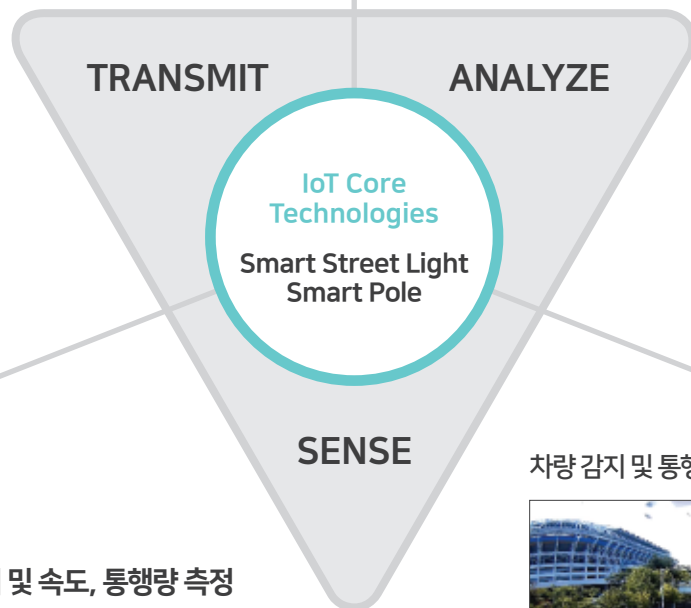
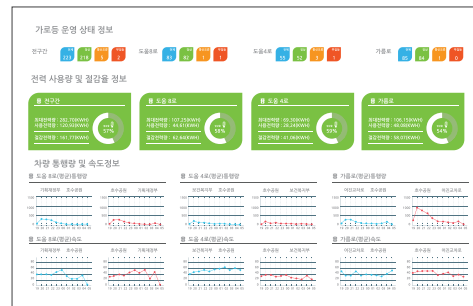

radar 센서 기반

도로상의 사물 감지 및 속도, 통행량 측정

Traffic and pedestrian counting by RADAR sensor

- FMCW 레이더센서 기반의 차량 및 보행자 통행자 카운팅 디바이스를 도로 시설물(신호등주, 가로등주, 하이패스 등)에 설치
- 통행량 측정 대상 도로의 환경 변수(차선 수/폭, 장치 설치차선/높이, 감지거리 Min/Max, 감지속도 Max 및 감지각도)를 설정
- 설치된 센서 디바이스로부터 취합되는 Raw Data에 Clustering과 Tracking 알고리즘을 적용하여 통행량과 속도 정보를 감지

디바이스 설치위치

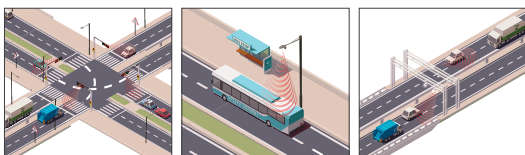

신호등주

가로등주

하이패스

차량 감지 및 통행량 측정

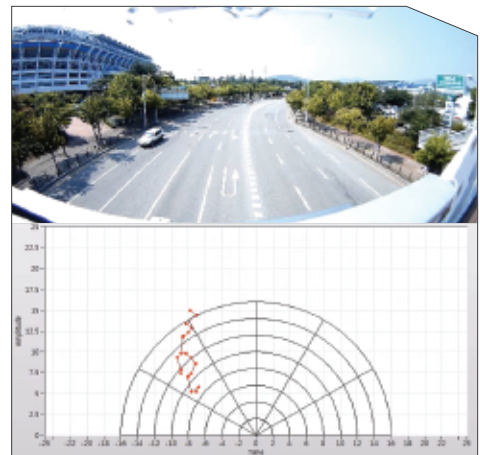

보행자 감지 및 통행량 측정



사물인터넷(IoT)기술 기반으로 “시간대별 주변의 밝기, 차량과 사람의 움직임과 통행량” 같은 동적인 도로 상황을 감지하여, 자동 또는 원격으로 가로등의 조도 및 동작이 제어되는 가로등

IoT technologies enable public street lights to recognize and sense movement of vehicles and pedestrians and control lightness by itself. The smart street light reduces energy consumption, light pollution and increases roadway safety.



안전한 도로조명



전기에너지 저감



빛 공해 감소



도시공익 정보 제공



교통량 빅 데이터 분석 기반 다이내믹 디밍 설정

Traffic Big Data Analysis

스마트센서에 의해 취합된 도로구간 별, 시간대별 차량 통행량과 평균 속도 교통량 빅 데이터를 분석하여, 도로 구간별, 가로등 별 기본 디밍율과 Lighting Zone 다이내믹 디밍 제어 Relay수를 차등 설정

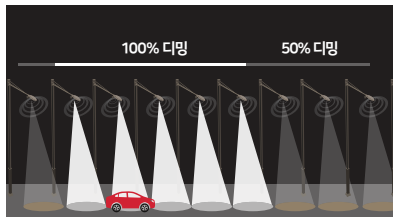

Lighting Zone 설정 및 다이내믹 디밍 제어

Dynamic Dimming Control by Lighting Zone

가로등의 밝기를 기본 디밍 수준으로 낮춘 상태에서 스마트센서에 의해 차량 접근이 감지되면, 차량의 속도를 감안하여 전방 100m까지 100% 디밍 수준으로 밝기를 밝게 조절하고, 차량이 통과하고 후속 차량이 없으면, 다시 밝기가 천천히 기본 디밍 수준으로 낮춰 지도록 밝기를 자동 제어



스마트 가로등 운영상태 및 전기에너지 사용/ 절감량 모니터링

Failure Detection and Energy Consumption Monitoring by Remote

스마트센서에 의해 취합된 가로등 별 운영상태(정상, 부점등, 통신이상) 및 전기에너지 사용량과 절감량 정보를 관제시스템을 통하여 모니터링
절감량 : **사용 전력량 42.6%** 절감, 전기요금 37.9% 절감

시스템 개요도 System Architecture

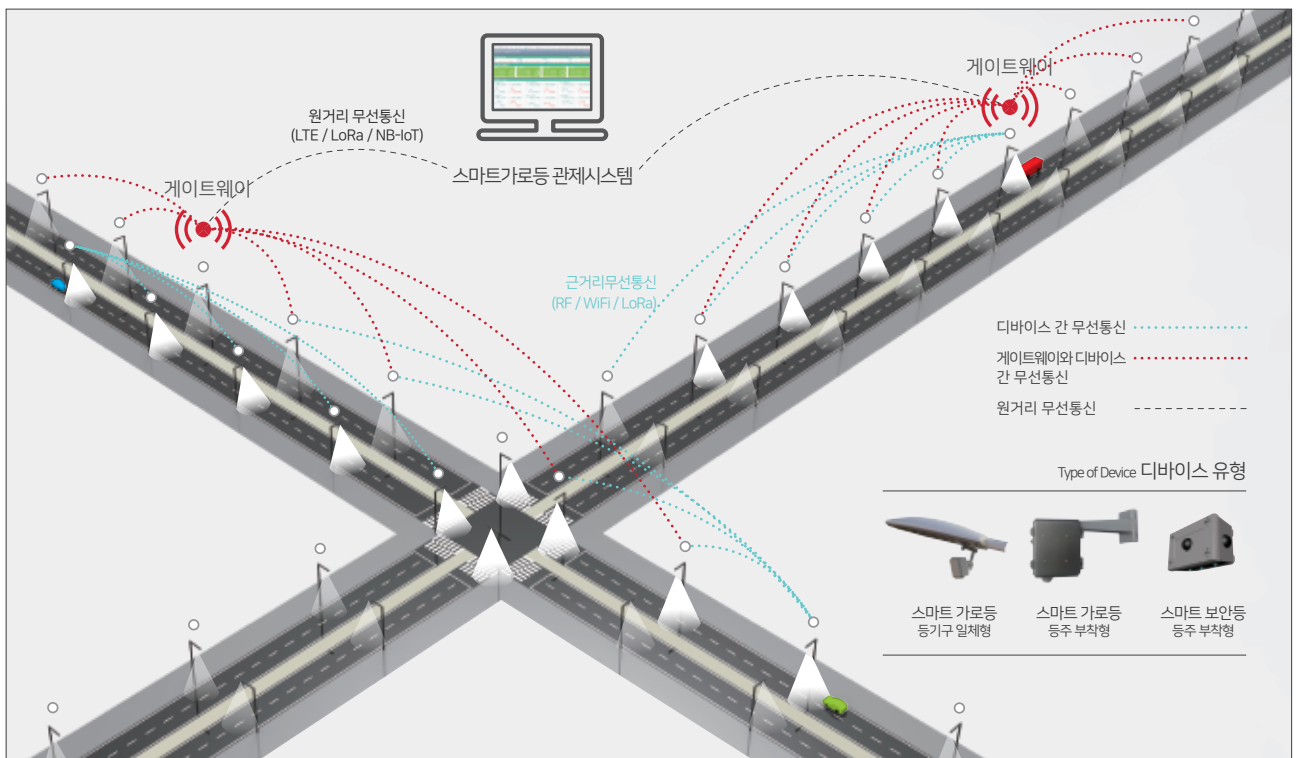

LED 보안등 조명에 스마트센서, 무선통신 및 원격 관제/빅 데이터 분석의 사물인터넷 기술을 융합하여 LED 보안등의 획기적인 전기에너지 저감, 주거 지역의 빛 공해 저감, 보행 시민의 안전, 유지관리 비용 절감 할 수 있는 스마트시티 서비스

IoT technologies enable public street lights to recognize and sense movement of vehicles and pedestrians and control lightness by itself. The smart street light reduces energy consumption, light pollution and increases roadway safety.



보행 시민의 안전 제고

보행 시민 감지에 따른 다이내믹 디밍
보행 안전 제고 및 범죄 예방



획기적인 전기에너지 저감

다이내믹 디밍 운용시 전기에너지 저감 55%이상
CO2 감소와 탄소세 절감(1.4원/kW)



주거 지역의 빛 공해 저감

시간대별 일괄 또는 개별 디밍제어



안전한 도시 보안등 유지 및 관리

점소등 시간 일괄 관리
부점등 등 다양한 고장 원인 관리



도시 및 주거 지역 공익 정보 제공

미세먼지 등 대기환경정보 수집 및 표출
IoT센서 & 무선망 활용 정보 획득
추가 센서 도입 가능

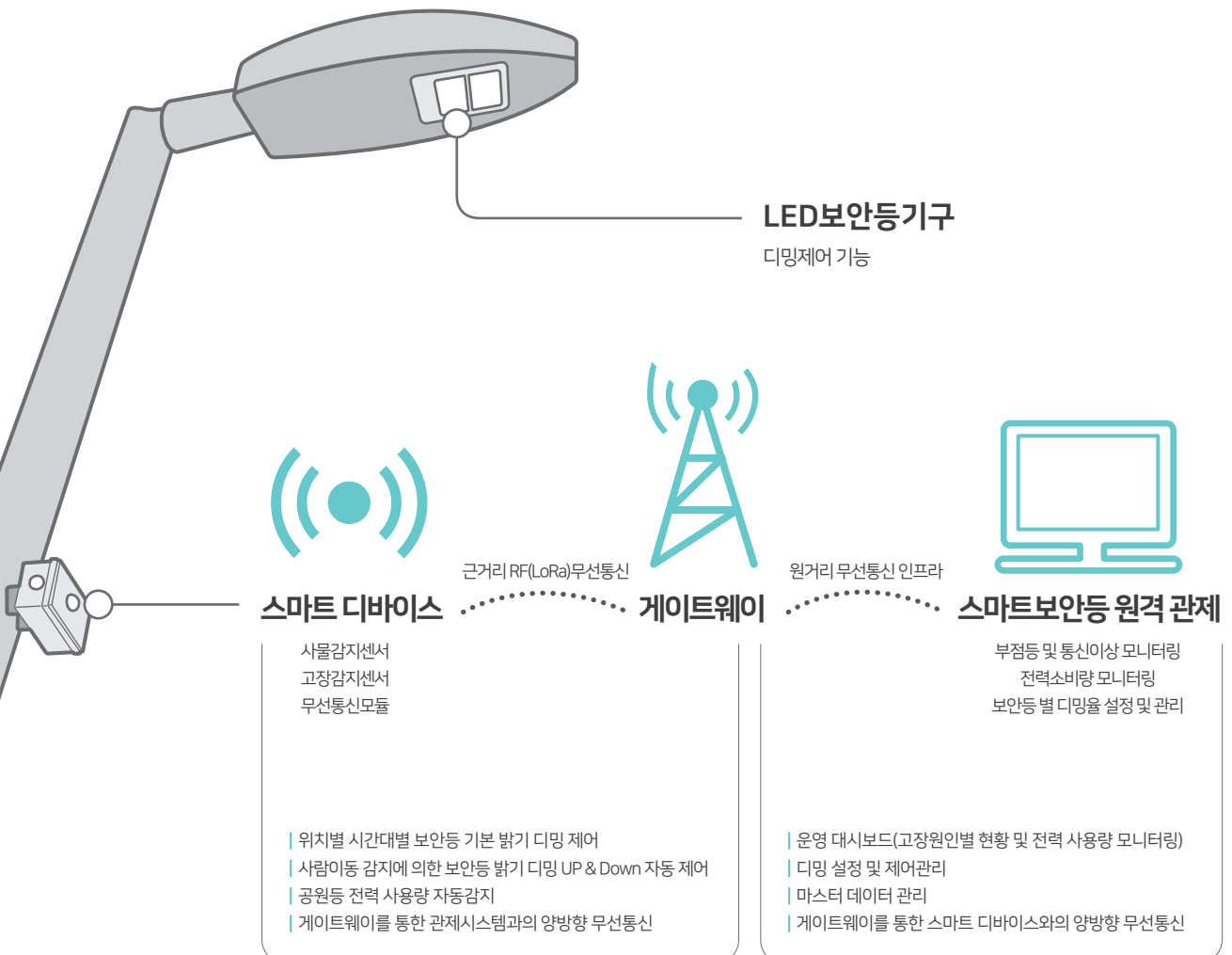

스마트 폴 Smart Pole

사물인터넷 기술 기반으로 시민 안전, 도시 범죄/테러 예방/감시, 시민 생활편의 제공 및 지능형교통시스템과 자율자동차를 위한 스마트 도로인프라 제공을 목적으로 제작된 고효율 스마트 도로조명 시스템

The Smart Pole is a turn-key Smart Product, utilizing IoT technologies embedded within steel and aluminum poles for public safety, crime prevention, surveillance, anti-terrorism and numerous lighting applications.



<p>고효율 스마트 도로조명 Smart & Intelligent Lighting System</p> <p>도로 이용자 자동감지에 따른 조명 밝기 제어와 원격 자동 고장 감지</p>	<p>도로 돌발상황 감지 Road Incident Detection</p> <p>주정차 역주행 도로파손 / 침수 경사지 붕괴 감지 센서 융합 (C-ITS 및 자율자동차 연계)</p>
<p>공공 Wifi 무선통신 인프라 Wifi Hotspot Service</p>	<p>자율자동차 무선통신 인프라 Pole-to-Vehicle (Bluetooth) Wireless Communication</p>
<p>영상 네트워크 City Surveillance HD CCTV Camera</p>	<p>대기환경정보 측정 Environmental Sensors</p> <p>미세먼지 PM 10 초미세먼지 PM 2.5 이산화질소 NO₂ 일산화탄소 CO 야황산가스 SO₂</p>
<p>보안 SOS Application</p> <p>비콘센서와 스마트폰 앱 연동 비상벨 양방향 스피커 경광등 영상센서</p>	<p>전기차 / 퍼스널 모빌리티 충전 서비스 EV / Personal Mobility Charging Service</p>
<p>LED 전광판 Signage LED 디스플레이 (지역정보 및 도시공익정보)</p>	

서비스 개요도 Service Overview

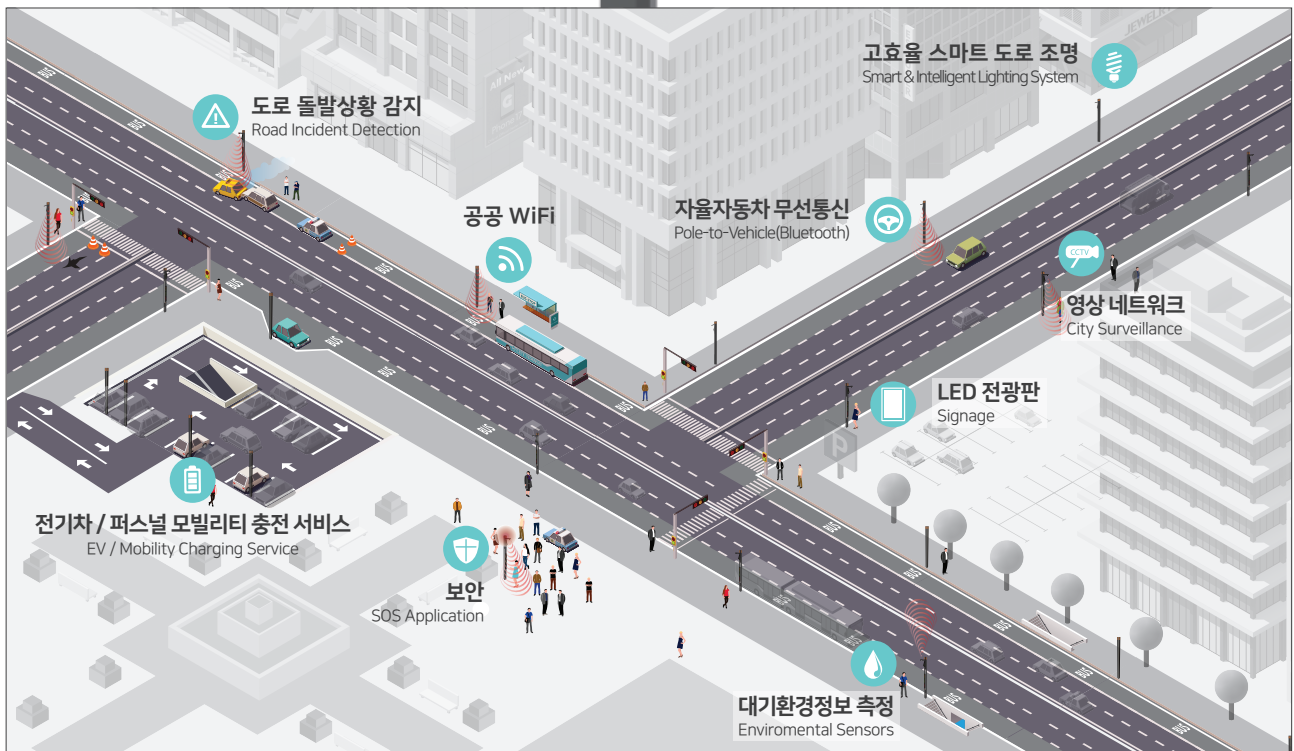

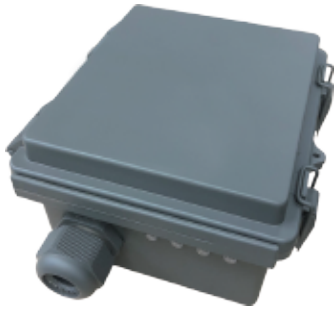

스마트가로등 디바이스 Smart Street Light Device

MODEL	물품식별번호	전자파적합등록
EPSLS-D (LoRa)	23673442	R-R-epl-EPSLS-D
EPSLS-R (릴레이)	23673443	R-R-epl-EPSLS-D
EPSLS-C (상시)	23673444	R-R-epl-EPSLS-D
EPSLS-F (FMCW, 속도 및 차량감지)	23673445	R-R-epl-EPSLS-F

스마트보안등 디바이스 Smart Security Light Device

MODEL	물품식별번호	전자파적합등록
EPSP-P3 (단독형)	23673448	R-R-epl-EPSP-P3N
EPSP-P3N (연계형)	23673447	R-R-epl-EPSP-P3N



게이트웨이 Gateway

MODEL	물품식별번호	전자파적합등록
EPSP-GW	23673446	R-R-epl-EPSLS-F

관제시스템 Control System

MODEL	물품식별번호
EPSPGM-SVR (보안등관제시스템)	23673888
EPSPLM-SVR (가로등관제시스템)	23673887





스마트폴 Smart Pole

MODEL	HEIGHT	물품식별번호
EPL-SP50	5m	23587714
EPL-SP75	6m	23587715
EPL-SP100	8m	23587716

스마트폴 옵션 Smart Pole Option



삼각

원형

사각

LED 조명	LED 가로등기구, LED 보안등기구, 경관조명
센서	사물·사람 감지 센서 보도용 사물감지센서(사람 이동 감지) 물감지·충격감지·지진감지 센서 조도센서·공기질 센서·온습도센서·풍속센서
CCTV	회전형, 고정형

공공 Wi-Fi, 5G, 4G	공공 통신망 제공
충전기	모바일 충전기, 모빌리티 충전기, 전기자동차 충전기
디스플레이	LED, LCD
비상벨	경광등·스피커 연동, 관제 연결
스마트제터	공공 정보 이미지 제공



경기도 김포시 하성면 귀전로 172-24
T : 031.989.8678 | F : 031.998.4673
www.epelkorea.co.kr | epelkorea@naver.com